

May.1.2017 Copyright 2017 HIROSE ELECTRIC CO., LTD. All Rights Reserved.

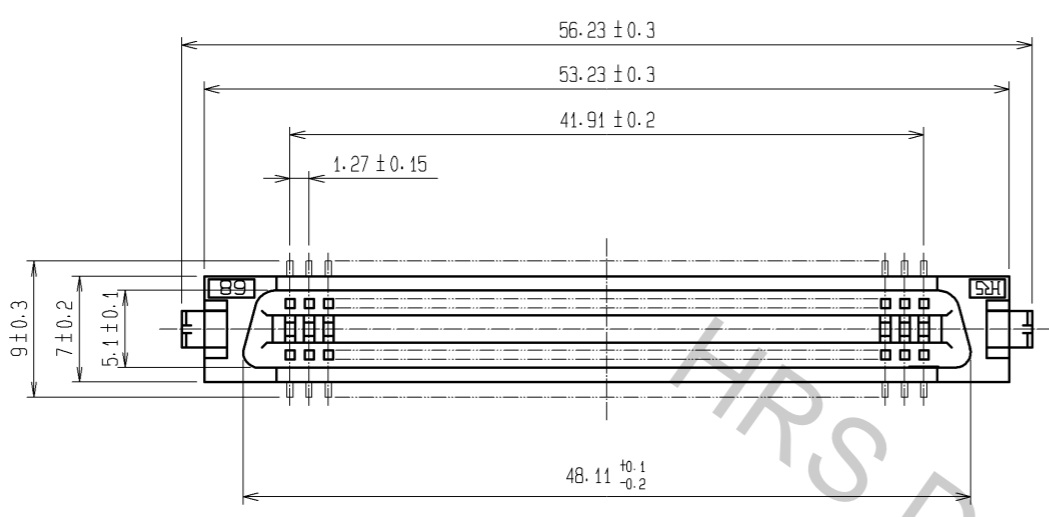

RECOMMENDED LAND PATTERN DIMENSION OF PCB (MOUNTING SIDE)

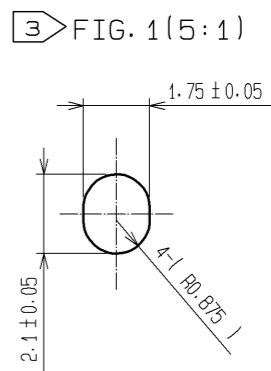
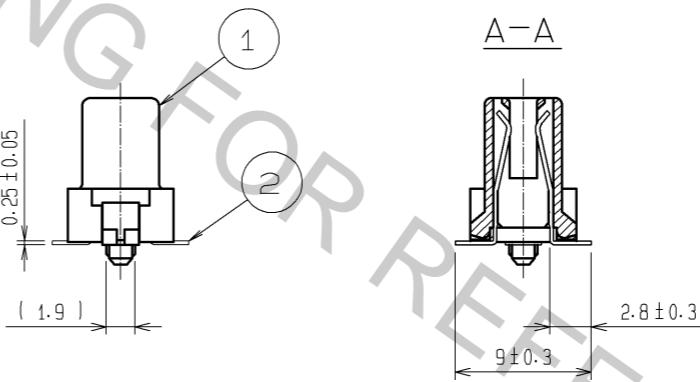
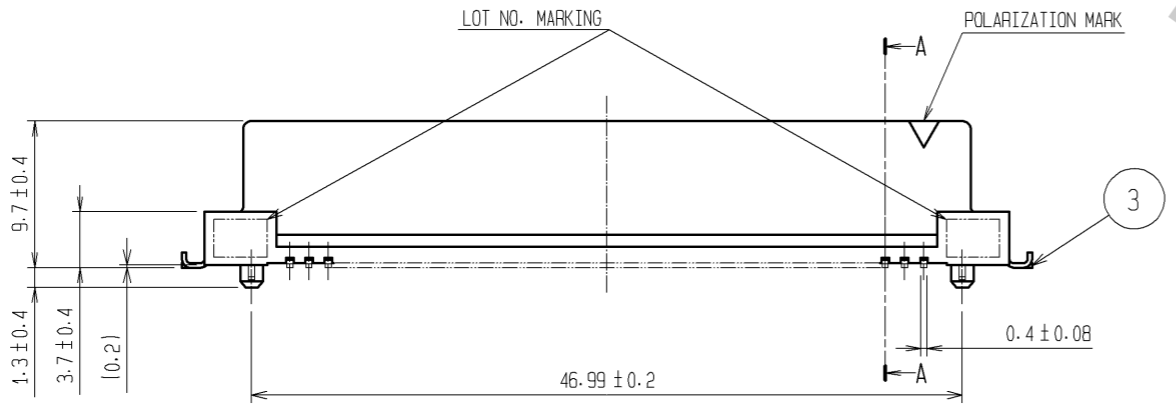
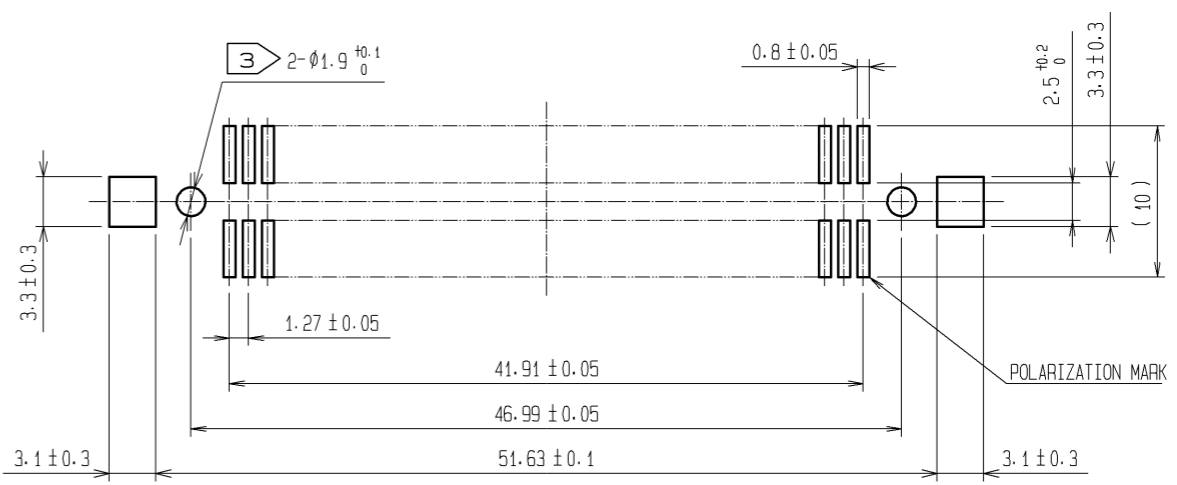

- NOTES 1 LEAD CO-PLANARITY SHALL BE 0.15 MAX.
 2 THE DIMENSIONS IN PARENTHESES ARE FOR REFERENCE.
 3 IN CASE OF THE AUTOMATED MOUNTING, RECOMMENDED HOLE DIAMETER OF BOSS IS SHOWN IN FIG. 1.

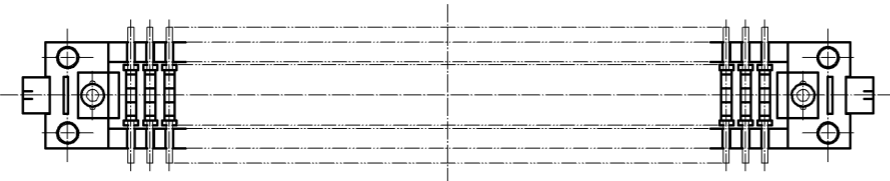

1	PPS	LIGHT BROWN (UL94V-0)	3	BRASS	TIN-PLATING
			2	PHOSPHOR BRONZE	CONTACT AREA:GOLD 0.2µm min.
					LEAD AREA:TIN-PLATING 2µm min.
					UNDER PLATING:NICKEL 1.5µm min.
NO.	MATERIAL	FINISH . REMARKS	NO.	MATERIAL	FINISH . REMARKS
UNITS mm		SCALE 2 : 1	COUNT 	DESCRIPTION OF REVISIONS	DESIGNED
					CHECKED
					DATE
APPROVED : HS. OKAWA 07. 10. 19			DRAWING NO. EDC3-082421-21		
CHECED : HS. OZAWA 07. 10. 19			PART NO. FX2-68S-1. 27SVL(71)		
DESIGNED : SY. KAMIGA 07. 10. 19			CODE NO. CL572-2156-5-71		
DRAWN : HK. SUNADORI 07. 10. 19					