

Regulations No.	1824S02E	Total Pages	Page
		24	1

The product specifications described in this book are subject to change without notice for the product which is currently under development. At the final stage of your design, purchasing, or use of the product, therefore, ask for the most up-to-date Product Standards in advance to make sure that the latest specifications satisfy your requirements.

User's Guide for Evaluation Board

Part No.	AN30182A-EVB
----------	--------------

Automotive & Industrial Systems Company
Panasonic Corporation

	2013-05-15	
	Revised	

Regulations No.	1824S02E	User's Guide for Evaluation Board	AN30182A-EVB	
			Total Pages	Page
			24	2

Contents

1 Introduction

1.1	Overview	3
1.2	Features	3
1.3	Applications	3
1.4	Package	3
1.5	Type	3
1.6	Simplified Application Circuit.....	4

2 Evaluation Board

2.1	Structure	5
2.2	Connection	5
2.3	Appearance	6
2.4	Switches and Jumper Setup	7

3 Schematic

	8
--	---

4 Operating Procedure

4.1	Start of Process	9
4.2	Operation Instructions	10
4.3	Register Contents	11
4.4	Register Map	12

5 Bill of Materials

	20
--	----

6 Board Layout

	21
--	----

Usage Notes	24
-------------------	----

	2013-05-15	
	Revised	

Regulations No.	1824S02E	<h1 style="margin: 0;">User's Guide for Evaluation Board</h1>	AN30182A-EVB	
			Total Pages	Page
			24	3

1 Introduction

This user's guide contains background information for the

AN30182A : Multi Power Supply (High Efficiency Power LSI)

as well as support documentation for the AN30182A Evaluation Board (AN30182A-EVB). Also included are the schematic, the bill of materials and the Board Layout for the Evaluation Board.

1.1 Overview

AN30182A is a multi power supply LSI which has high-speed response DC-DC Step Down Regulators (2-ch) and LDO Regulators (6-ch).

The output DC of each power supply is variable by I2C control.

1.2 Features

- DC-DC Step Down Regulator 2-ch (Output voltage 0.8 V to 2.4 V, Output current 600 mA)
- Regulator 6-ch (Output voltage 1.0 V to 3.3 V, Output current 300 mA)
- I2C control (2-slave address selectable)
- Input Voltage Range: VBAT: 2.5V~ 5.5V , DVDD: 1.7V ~ 3.0V
- Built-in Under Voltage Lockout (UVLO), Thermal Shut Down (TSD), Output Over-Current Protection (OCP), Short-Circuit Protection (SCP) functions

Input voltage and output current range for the evaluation Board are given in Table 1.

Table 1. Input Voltage and Output Current Summary

Evaluation Board	Input Voltage range	Output Current Range
EVB-AN30182A	VBAT = 2.5V ~ 5.5V DVDD = 1.7V ~ 3.0V	DC-DC Step Down Regulator: 0.8 V ~ 2.4 V , 600 mA LDO Regulator: 1.0 V ~ 3.3 V , 300 mA

1.3 Applications

- Portable appliance, etc

1.4 Package

- 25 pin Wafer Level Chip Size Package (WLCSP)
(Size : 2.15 mm 2.15 mm, 0.4 mm Pitch)

1.5 Type

- Bi-CMOS IC

Note: The parameters above is subject to change for improvement without notice.

	2013-05-15	
	Revised	

Regulations No.	1824S02E	User's Guide for Evaluation Board		AN30182A-EVB	
				Total Pages	Page
				24	4

1.6 Simplified Application Circuit

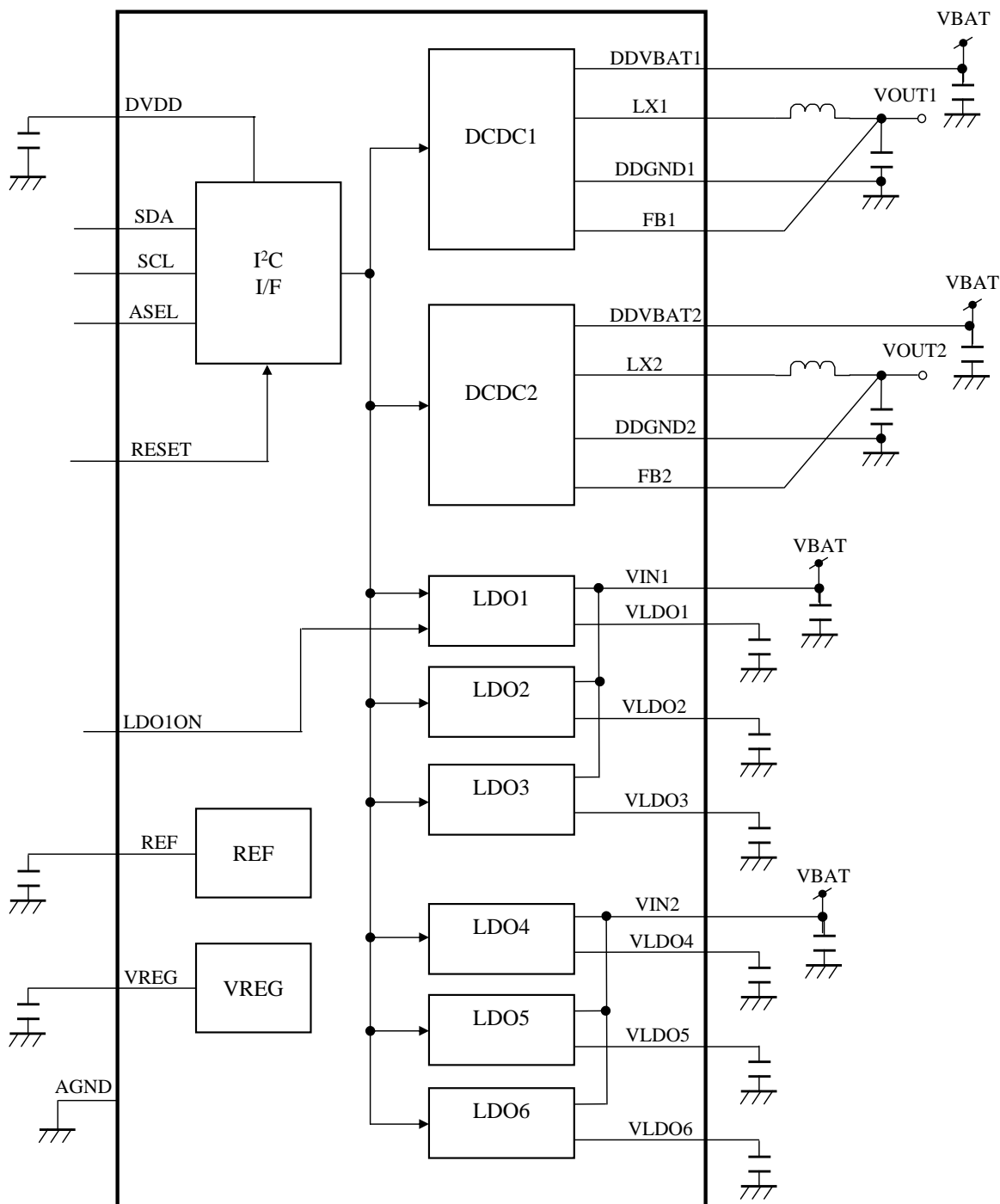

Figure 1. Block Diagram

- Notes)
- This application circuit is an example. The operation of mass production set is not guaranteed. You should perform enough evaluation and verification on the design of mass production set. You are fully responsible for the incorporation of the above application circuit and information in the design of your equipment.
 - This block diagram is for explaining functions. Part of the block diagram may be omitted, or it may be simplified.

	2013-05-15	
	Revised	

Regulations No.	1824S02E	<h1>User's Guide for Evaluation Board</h1>	AN30182A-EVB	
			Total Pages	Page
			24	5

2 Evaluation Board

This section describes Structure, Connection and Main Test Points of Evaluation Board.

2.1 Structure

Evaluation Board consists of **AN30182A Evaluation Board** and **USB Microcontroller Board** as figure 2. IIC connector of AN30182A Evaluation Board is connected to CN1 of USB Microcontroller Board by a cable.

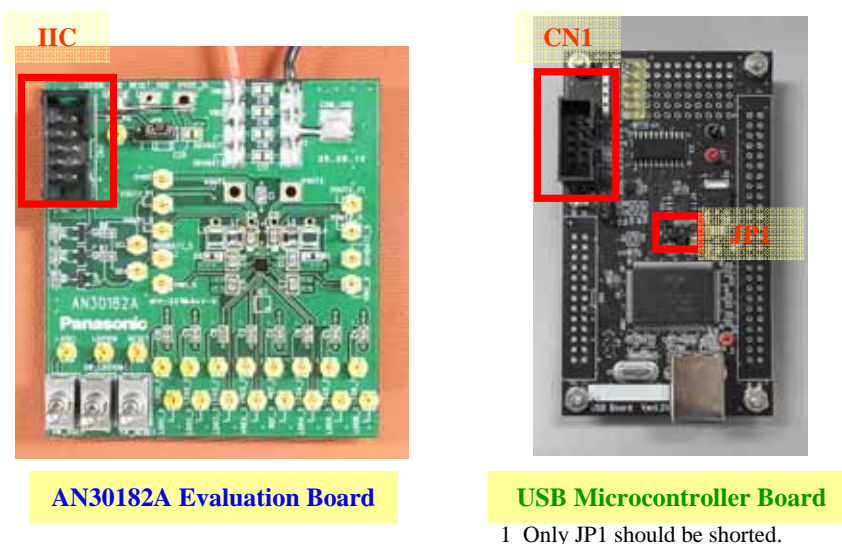

Figure 2. Structure of Evaluation Board

2.2 Connection

Evaluation Board should be connected to PC with USB Cable as Figure 3.

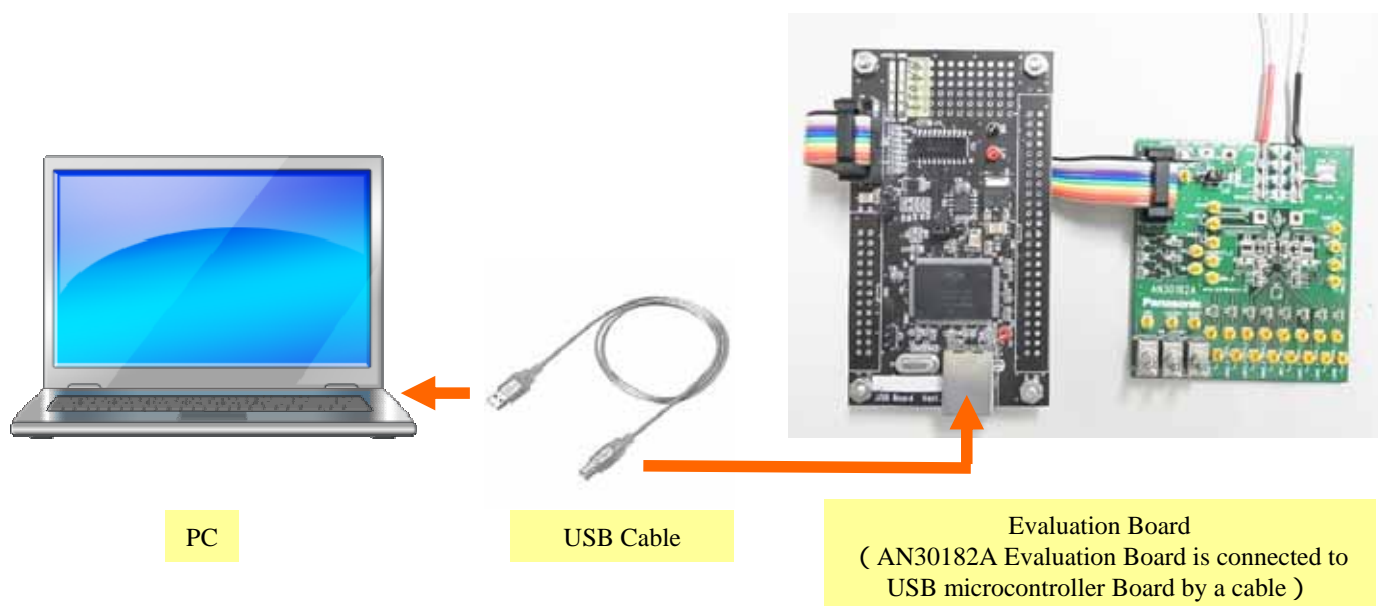

Figure 3. Connection of Evaluation Board and PC

Note: The parameters above is subject to change for improvement without notice.

	2013-05-15	
	Revised	

Regulations No.	1824S02E	User's Guide for Evaluation Board		AN30182A-EVB	
				Total Pages	Page
				24	6

2.3 Appearance

Figure 4 shows the appearance of AN30182A Evaluation Board.

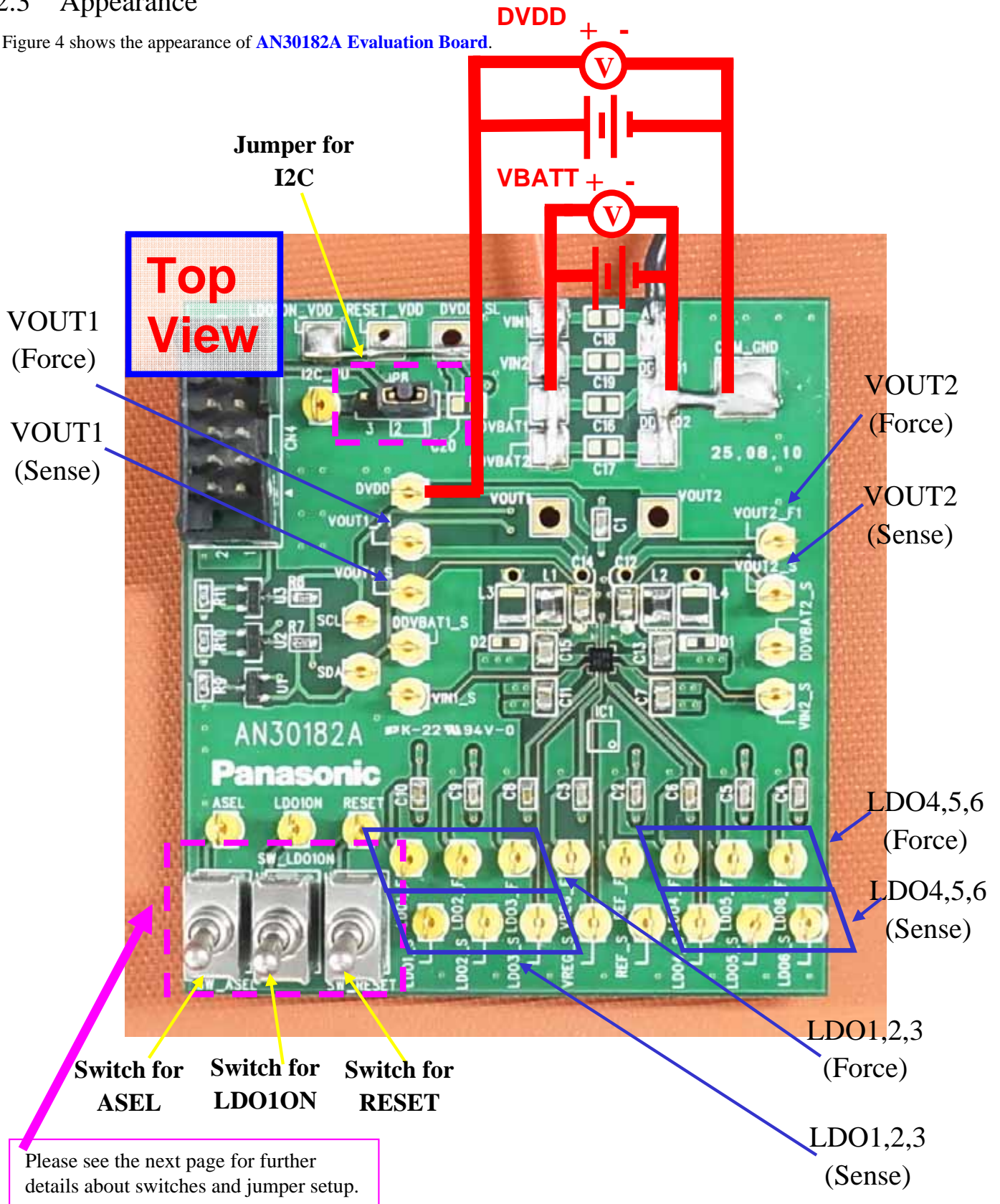

Figure 4. Appearance of AN30182A Evaluation Board (Top View)

Note: The parameters above is subject to change for improvement without notice.

	2013-05-15	
	Revised	

Regulations No.	1824S02E	<h1>User's Guide for Evaluation Board</h1>	AN30182A-EVB	
			Total Pages	Page
			24	7

2.4 Switches and Jumper Setup

ASEL pin, LDO1ON pin and RESET pin are able to be controlled by SW-ASEL, SW-LDO1ON and SW-RESET (Figure 5).

JP8 supplies the voltage for I2C communications to USB Microcontroller Board. Connect the pin1 to the pin2 to be shown in figure 6 for evaluation.



Figure 5. Appearance of SW-ASEL, SW-LDO1ON and SW-RESET

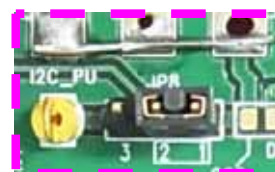

Figure 6. Appearance of JP8

Table2-4 presents the setup of switches.

Table 2. SW-ASEL
(Control I2C slave address)

Slave Address	73h	72h
Switch		

Table 3. SW-LDO1ON
(Control LDO1 enable)

LDO1	ON	OFF ¹
Switch		

¹ LDO1ON can be turned on by serial controller regardless of the setup.

Table 4. SW-RESET
(Reset AN30182A IC)

Reset	Enable	Unable
Switch		

Note: The parameters above is subject to change for improvement without notice.

	2013-05-15	
	Revised	

Regulations No.	1824S02E	User's Guide for Evaluation Board		AN30182A-EVB	
				Total Pages	Page
				24	8

3 Schematic

Figure 7 shows the schematic of AN30183A Evaluation Board .

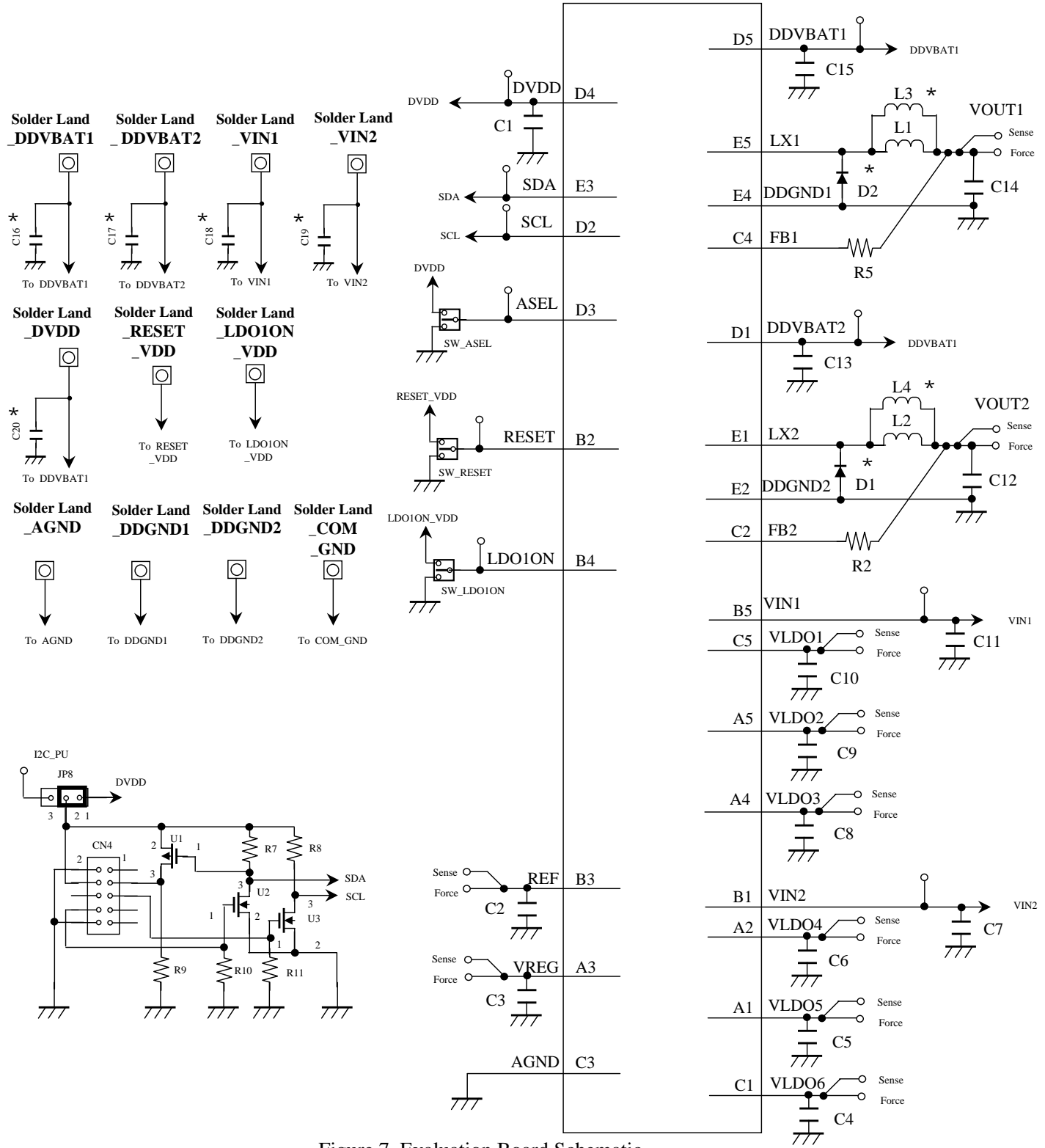

Figure 7. Evaluation Board Schematic

* : Not Installed

Note: The parameters above is subject to change for improvement without notice.

	2013-05-15	
	Revised	

Regulations No.	1824S02E	<h1>User's Guide for Evaluation Board</h1>	AN30182A-EVB	
			Total Pages	Page
			24	9

4 Operating Procedure

This section describes how to use Evaluation Board and Serial Controller software.

4.1 Start of Process

- 1) Connect Evaluation Board to PC with USB Cable. (cf. section 2.2)
- 2) Supply VBAT = 2.5 ~ 5.5V and DVDD=1.7 ~ 3.0V on Evaluation Board.
- 3) Before using Evaluation Board, Installation of a program to PC is needed.
Please refer to the file : Install Manual of Serial Controller(AN30182A).pdf
If this has ever been done, ignore this step.
- 4) Start up the Serial Controller software : AN301820_Serial Controller ver1.0a.exe
- 5) In the opening window, Choose [NEW TYPE(EXUSB_FX2)I2C Control] button.

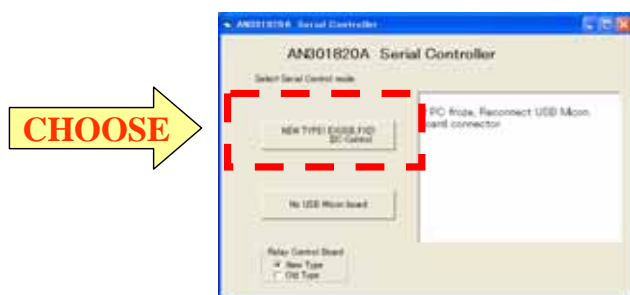

Figure 8. Starting Window of Serial Controller Software

- 6) Serial Controller Software starts.

Note: The parameters above is subject to change for improvement without notice.

	2013-05-15	
	Revised	

Regulations No.	1824S02E	User's Guide for Evaluation Board		AN30182A-EVB	
				Total Pages	Page
				24	10

4.2 Operating Instructions

Operating Instructions on Operating window of Serial Controller software.

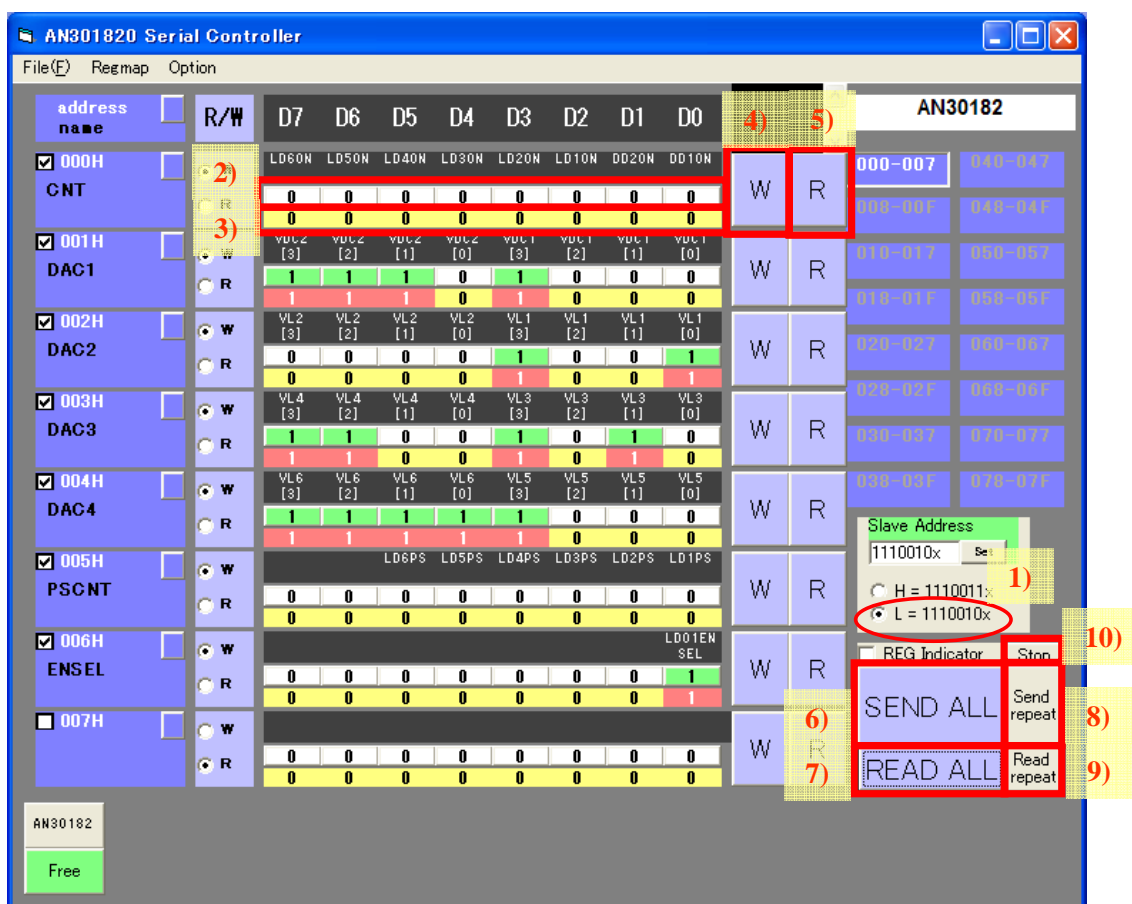

Figure 9. Operating Instructions on Operating Window of Serial Controller Software

- 1) Slave Address
Set Slave Address of I2C communication. Choose [L=1110010x]. Choose the same one as the SW_ASEL setting on AN30182A Evaluation Board.
- 2) Set Write Data
Click the bit data you want to change, the data will be changed 0 1 or 1 0.
- 3) Indicate Read Data
8bit binary data read from AN30182A IC is indicated.
- 4) Write Data (1 Address)
Send the write data set at 2)
- 5) Read Data (1 Address)
Read 8bit binary data from AN30182A IC and indicate at 3).
- 6) Write Data (All Address)
Send all write data set in the operating window.
- 7) Read Data (All Address)
Read all data from AN30182A IC and indicate to the operating window.
- 8) Write Data (All Address) Repeatedly
Repeat 6) infinitely.
- 9) Read Data (All Address) Repeatedly
Repeat 7) infinitely.
- 10) Stop
Stop 8) and 9).

Note: The parameters above is subject to change for improvement without notice.

	2013-05-15	
	Revised	

Regulations No.	1824S02E	<h1>User's Guide for Evaluation Board</h1>	AN30182A-EVB	
			Total Pages	Page
			24	11

4.3 Register Contents

This section describes register contents on operating window of serial controller software. For further details, please refer to the register map in section 4.4.



Figure 10. Register Contents on Operating Window of Serial Controller Software

- 1) every LDO and DCDC ON/OFF select register
- 2) Register for output voltage setup of DCDC1
- 3) Register for output voltage setup of DCDC2
- 4) Register for output voltage setup of LDO1
- 5) Register for output voltage setup of LDO2
- 6) Register for output voltage setup of LDO3
- 7) Register for output voltage setup of LDO4
- 8) Register for output voltage setup of LDO5
- 9) Register for output voltage setup of LDO6
- 10) every LDO Power save mode select register
- 11) LDO1EN Enable

e.g. LDO1=3.3V:ON (Power save mode)

- 1) Write 000H(Address), 04H(Data) : LDO1:ON
- 4) Write 002H(Address), 0FH(Data) : LDO1=3.3V
- 10) Write 005H(Address), 01H(Data) : Power save mode

Note: The parameters above is subject to change for improvement without notice.

	2013-05-15	
	Revised	

Regulations No.	1824S02E	<h1 style="margin: 0;">User's Guide</h1> <h2 style="margin: 0;">for Evaluation Board</h2>	AN30182A-EVB	
			Total Pages	Page
			24	12

4.4 Register Map

This section describes register map and details of registers.

Table 5. Register Map

Sub Address	R/W	Register Name	Bit	Data							
				D7	D6	D5	D4	D3	D2	D1	D0
00h	R/W	CNT	Name	LD6ON	LD5ON	LD4ON	LD3ON	LD2ON	LD1ON	DD2ON	DD1ON
			Default	0	0	0	0	0	0	0	0
01h	R/W	DAC1	Name	VDC2[3:0]				VDC1[3:0]			
			Default	1	1	1	0	1	0	0	0
02h	R/W	DAC2	Name	VL2[3:0]				VL1[3:0]			
			Default	0	0	0	0	1	0	0	1
03h	R/W	DAC3	Name	VL4[3:0]				VL3[3:0]			
			Default	1	1	0	0	1	0	1	0
04h	R/W	DAC4	Name	VL6[3:0]				VL5[3:0]			
			Default	1	1	1	1	1	0	0	0
05h	R/W	PSCNT	Name	-	-	LD6PS	LD5PS	LD4PS	LD3PS	LD2PS	LD1PS
			Default	-	-	0	0	0	0	0	0
06h	R/W	ENSEL	Name	-	-	-	-	-	-	-	LDO1EN SEL
			Default	-	-	-	-	-	-	-	-

Initial voltage	LDO6	LDO5	LDO4	LDO3	LDO2	LDO1	DCDC2	DCDC1
	3.3 V	1.8 V	2.8 V	2.6 V	1.0 V	1.85 V	1.85 V	1.2 V

Note: The parameters above is subject to change for improvement without notice.

	2013-05-15	
	Revised	

Regulations No.	1824S02E	User's Guide for Evaluation Board	AN30182A-EVB	
			Total Pages	Page
			24	13

Table 6. Register 00h

Sub Address	R/W	Register Name	Bit	Data							
				D7	D6	D5	D4	D3	D2	D1	D0
00h	R/W	CNT	Name	LD6ON	LD5ON	LD4ON	LD3ON	LD2ON	LD1ON	DD2ON	DD1ON
			Default	0	0	0	0	0	0	0	0

D7 : LDO6 ON/OFF select register

[0] : OFF (default)

[1] : ON

D6 : LDO5 ON/OFF select register

[0] : OFF (default)

[1] : ON

D5 : LDO4 ON/OFF select register

[0] : OFF (default)

[1] : ON

D4 : LDO3 ON/OFF select register

[0] : OFF (default)

[1] : ON

D3 : LDO2 ON/OFF select register

[0] : OFF (default)

[1] : ON

D2 : LDO1 ON/OFF select register

[0] : OFF (default)

[1] : ON

D1 : DCDC2 ON/OFF select register

[0] : OFF (default)

[1] : ON

D0 : DCDC1 ON/OFF select register

[0] : OFF (default)

[1] : ON

Note: The parameters above is subject to change for improvement without notice.

	2013-05-15	
	Revised	

Regulations No.	1824S02E	User's Guide for Evaluation Board				AN30182A-EVB	
						Total Pages	Page
				24	14		

Table 7. Register 01h

Sub Address	R/W	Register Name	Bit	Data							
				D7	D6	D5	D4	D3	D2	D1	D0
01h	R/W	DAC1	Name	VDC2[3:0]				VDC1[3:0]			
			Default	1	1	1	0	1	0	0	0

D7-4 : DCDC2 Register for output voltage setup

D3-0 : DCDC1 Register for output voltage setup

VDC2[3:0]				Output voltage [V]
D7	D6	D5	D4	
0	0	0	0	0.80
0	0	0	1	0.85
0	0	1	0	0.90
0	0	1	1	0.95
0	1	0	0	1.00
0	1	0	1	1.05
0	1	1	0	1.10
0	1	1	1	1.15
1	0	0	0	1.20
1	0	0	1	1.30
1	0	1	0	1.40
1	0	1	1	1.50
1	1	0	0	1.65
1	1	0	1	1.80
1	1	1	0	1.85 (Default)
1	1	1	1	2.40

VDC1[3:0]				Output voltage [V]
D3	D2	D1	D0	
0	0	0	0	0.80
0	0	0	1	0.85
0	0	1	0	0.90
0	0	1	1	0.95
0	1	0	0	1.00
0	1	0	1	1.05
0	1	1	0	1.10
0	1	1	1	1.15
1	0	0	0	1.20 (Default)
1	0	0	1	1.30
1	0	1	0	1.40
1	0	1	1	1.50
1	1	0	0	1.65
1	1	0	1	1.80
1	1	1	0	1.85
1	1	1	1	2.40

Note: The parameters above is subject to change for improvement without notice.

	2013-05-15	
	Revised	

Regulations No.	1824S02E	User's Guide for Evaluation Board				AN30182A-EVB	
						Total Pages	Page
					24	15	

Table 8. Register 02 h

Sub Address	R/W	Register Name	Bit	Data							
				D7	D6	D5	D4	D3	D2	D1	D0
02h	R/W	DAC2	Name	VL2[3:0]				VL1[3:0]			
			Default	0	0	0	0	1	0	0	1

D7-4 : LDO2 Register for output voltage setup

D3-0 : LDO1 Register for output voltage setup

VL2[3:0]				Output voltage [V]
D7	D6	D5	D4	
0	0	0	0	1.00 (Default)
0	0	0	1	1.10
0	0	1	0	1.20
0	0	1	1	1.30
0	1	0	0	1.40
0	1	0	1	1.50
0	1	1	0	1.60
0	1	1	1	1.70
1	0	0	0	1.80
1	0	0	1	1.85
1	0	1	0	2.60
1	0	1	1	2.70
1	1	0	0	2.80
1	1	0	1	2.85
1	1	1	0	3.00
1	1	1	1	3.30

VL1[3:0]				Output voltage [V]
D3	D2	D1	D0	
0	0	0	0	1.00
0	0	0	1	1.10
0	0	1	0	1.20
0	0	1	1	1.30
0	1	0	0	1.40
0	1	0	1	1.50
0	1	1	0	1.60
0	1	1	1	1.70
1	0	0	0	1.80
1	0	0	1	1.85 (Default)
1	0	1	0	1.90
1	0	1	1	2.70
1	1	0	0	2.80
1	1	0	1	2.85
1	1	1	0	3.00
1	1	1	1	3.30

Note: The parameters above is subject to change for improvement without notice.

	2013-05-15	
	Revised	

Regulations No.	1824S02E	<h1 style="margin: 0;">User's Guide</h1> <h2 style="margin: 0;">for Evaluation Board</h2>	AN30182A-EVB	
			Total Pages	Page
			24	16

Table 9. Register 03h

Sub Address	R/W	Register Name	Bit	Data							
				D7	D6	D5	D4	D3	D2	D1	D0
03h	R/W	DAC3	Name	VL4[3:0]				VL3[3:0]			
			Default	1	1	0	0	1	0	1	0

D7-4 : LDO4 Register for output voltage setup

D3-0 : LDO3 Register for output voltage setup

VL4[3:0]				Output voltage [V]
D7	D6	D5	D4	
0	0	0	0	1.00
0	0	0	1	1.10
0	0	1	0	1.20
0	0	1	1	1.30
0	1	0	0	1.40
0	1	0	1	1.50
0	1	1	0	1.60
0	1	1	1	1.70
1	0	0	0	1.80
1	0	0	1	1.85
1	0	1	0	2.60
1	0	1	1	2.70
1	1	0	0	2.80 (Default)
1	1	0	1	2.85
1	1	1	0	3.00
1	1	1	1	3.30

VL3[3:0]				Output voltage [V]
D3	D2	D1	D0	
0	0	0	0	1.00
0	0	0	1	1.10
0	0	1	0	1.20
0	0	1	1	1.30
0	1	0	0	1.40
0	1	0	1	1.50
0	1	1	0	1.60
0	1	1	1	1.70
1	0	0	0	1.80
1	0	0	1	1.85
1	0	1	0	2.60 (Default)
1	0	1	1	2.70
1	1	0	0	2.80
1	1	0	1	2.85
1	1	1	0	3.00
1	1	1	1	3.30

Note: The parameters above is subject to change for improvement without notice.

	2013-05-15	
	Revised	

Regulations No.	1824S02E	<h1 style="margin: 0;">User's Guide</h1> <h2 style="margin: 0;">for Evaluation Board</h2>	AN30182A-EVB	
			Total Pages	Page
			24	17

Table 10. Register 04h

Sub Address	R/W	Register Name	Bit	Data							
				D7	D6	D5	D4	D3	D2	D1	D0
04h	R/W	DAC4	Name	VL6[3:0]				VL5[3:0]			
			Default	1	1	1	1	1	0	0	0

D7-4 : LDO6 Register for output voltage setup

D3-0 : LDO5 Register for output voltage setup

VL6[3:0]				Output voltage [V]
D7	D6	D5	D4	
0	0	0	0	1.00
0	0	0	1	1.10
0	0	1	0	1.20
0	0	1	1	1.30
0	1	0	0	1.40
0	1	0	1	1.50
0	1	1	0	1.60
0	1	1	1	1.70
1	0	0	0	1.80
1	0	0	1	1.85
1	0	1	0	2.60
1	0	1	1	2.70
1	1	0	0	2.80
1	1	0	1	2.85
1	1	1	0	3.00
1	1	1	1	3.30 (Default)

VL5[3:0]				Output voltage [V]
D3	D2	D1	D0	
0	0	0	0	1.00
0	0	0	1	1.10
0	0	1	0	1.20
0	0	1	1	1.30
0	1	0	0	1.40
0	1	0	1	1.50
0	1	1	0	1.60
0	1	1	1	1.70
1	0	0	0	1.80 (Default)
1	0	0	1	1.85
1	0	1	0	2.60
1	0	1	1	2.70
1	1	0	0	2.80
1	1	0	1	2.85
1	1	1	0	3.00
1	1	1	1	3.30

Note: The parameters above is subject to change for improvement without notice.

	2013-05-15	
	Revised	

Regulations No.	1824S02E	<h1>User's Guide for Evaluation Board</h1>	AN30182A-EVB	
			Total Pages	Page
			24	18

Table 11. Register 05 h

Sub Address	R/W	Register Name	Bit	Data							
				D7	D6	D5	D4	D3	D2	D1	D0
05h	R/W	PSCNT	Name	-	-	LD6PS	LD5PS	LD4PS	LD3PS	LD2PS	LD1PS
			Default	-	-	0	0	0	0	0	0

Please set it to normal mode when LDO starts.

D5 : LDO6 Power save mode select register

[0] : Normal mode (default)

[1] : Power save mode

D4 : LDO5 Power save mode select register

[0] : Normal mode (default)

[1] : Power save mode

D3 : LDO4 Power save mode select register

[0] : Normal mode (default)

[1] : Power save mode

D2 : LDO3 Power save mode select register

[0] : Normal mode (default)

[1] : Power save mode

D1 : LDO2 Power save mode select register

[0] : Normal mode (default)

[1] : Power save mode

D0 : LDO1 Power save mode select register

[0] : Normal mode (default)

[1] : Power save mode

Note: The parameters above is subject to change for improvement without notice.

	2013-05-15	
	Revised	

Regulations No.	1824S02E	<h1>User's Guide for Evaluation Board</h1>	AN30182A-EVB	
			Total Pages	Page
			24	19

Table 12. Register 06h

Sub Address	R/W	Register Name	Bit	Data								
				D7	D6	D5	D4	D3	D2	D1	D0	
06h	R/W	ENSEL	Name	-	-	-	-	-	-	-	-	LDO1ENSEL
			Default	-	-	-	-	-	-	-	-	1

D0 : LDO1ENSEL

[0] : LDO1ON control invalid

[1] : LDO1ON control valid (default)

Note: The parameters above is subject to change for improvement without notice.

	2013-05-15	
	Revised	

Regulations No.	1824S02E	User's Guide for Evaluation Board		AN30182A-EVB	
				Total Pages	Page
				24	20

5 Bill of Materials

Table 13 presents the bill of materials for **AN30182A Evaluation Board**.

Table 13. Evaluation Board Bill of Materials

Reference Designator	QTY	Value	Description	Size *3	Manufacturer	Part Number
C1	1	0.1uF	Capacitor, Ceramic, 16V, B, 10%	0603	MURATA	GRM188B11C104KA01
C2-6,C8-10	8	1uF	Capacitor, Ceramic, 10V, B, 10%	0603	MURATA	GRM185B31A105KE35
C7,C11,C13,C15	2	4.7uF	Capacitor, Ceramic, 16V, B, 10%	0805	MURATA	GRM21BBB1C475KA87
C12,C14	2	4.7uF	Capacitor, Ceramic, 10V, B, 10%	0805	MURATA	GRM21BBB1A475KA74
C16-20	-	-	-	-	-	-
R2,R5	2	0	Resistor, Chip, 0.1W	0603	Panasonic	ERJ3GEY0R00V
L1-2	2	1uH	INDUCTOR	0805	FDK	MIPSZ2012D1R0
L3-4	-	-	-	-	-	-
D1-2	-	-	-	-	-	-
SW_ASEL,SW_RESET, SW_LDO1ON	3	-	2stateSW_(with_Mid-point)	-	FUJISOKU	ATE1E-2M3-10-Z
CN4	1	-	-	-	HIROSE	HIF3FB-10PA_2.54DSA
JP8	-	-	-	-	-	-
U1	1	-	-	-	FAIRCHILD	FDV302P-PBF
U2-3	2	-	-	-	FAIRCHILD	FDV301N
R7-8	2	4.7K	Resistor, Chip, 0.1W, 5%	0603	Panasonic	ERJ3GEYJ472V
R9	1	1K	Resistor, Chip, 0.1W, 5%	0603	Panasonic	ERJ3GEYJ102V
R10-11	2	10K	Resistor, Chip, 0.1W, 5%	0603	Panasonic	ERJ3GEYJ103V

*3 : These values comply with EIA standards.

Note: The parameters above is subject to change for improvement without notice.

	2013-05-15	
	Revised	

Regulations No.	1824S02E	User's Guide for Evaluation Board		AN30182A-EVB	
				Total Pages	Page
		24	21		

6 Board Layout

The board layout for **AN30182A Evaluation Board** is shown in Figure 11 through Figure 16.

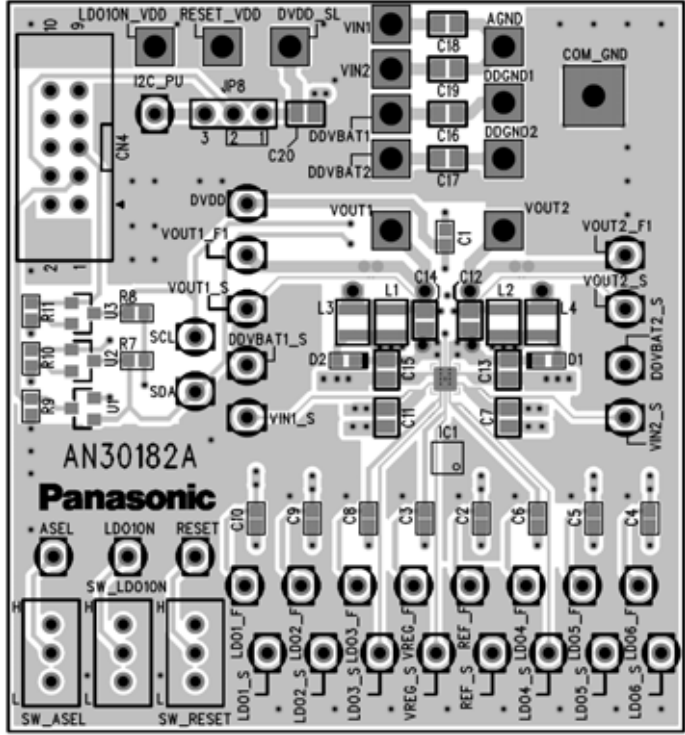

Figure 11. Top Layer with silk screen (Top View)

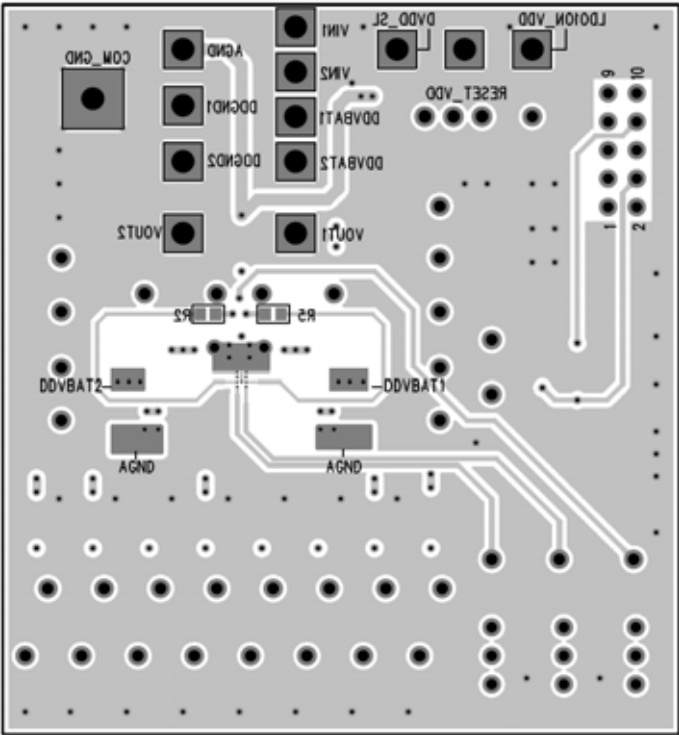

Figure 12. Bottom Layer with silk screen (Bottom View)

Note: The parameters above is subject to change for improvement without notice.

	2013-05-15	
	Revised	

Regulations No.	1824S02E	User's Guide for Evaluation Board	AN30182A-EVB	
			Total Pages	Page
			24	22

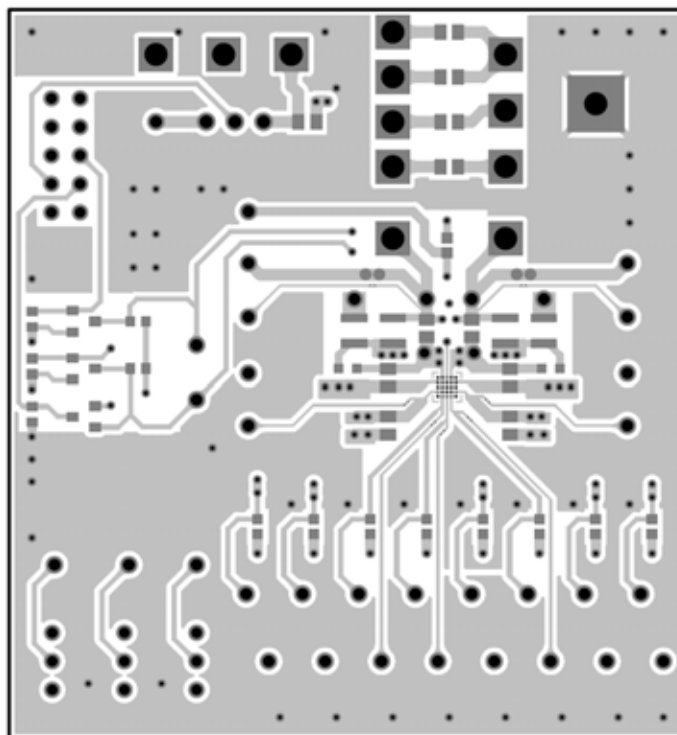

Figure 13. Top Layer (Top View)

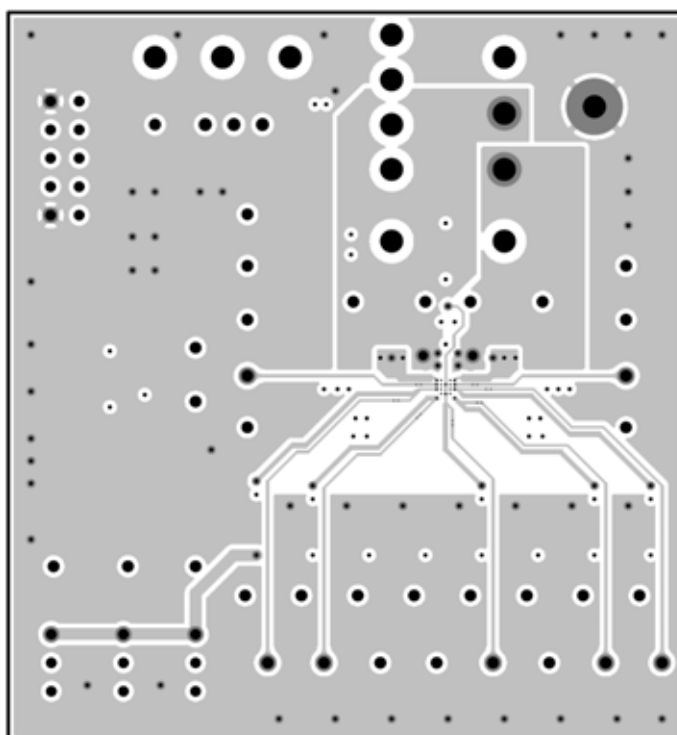

Figure 14. Layer 2 (Top View)

Note: The parameters above is subject to change for improvement without notice.

	2013-05-15	
	Revised	

Regulations No.	1824S02E	User's Guide for Evaluation Board	AN30182A-EVB	
			Total Pages	Page
			24	23

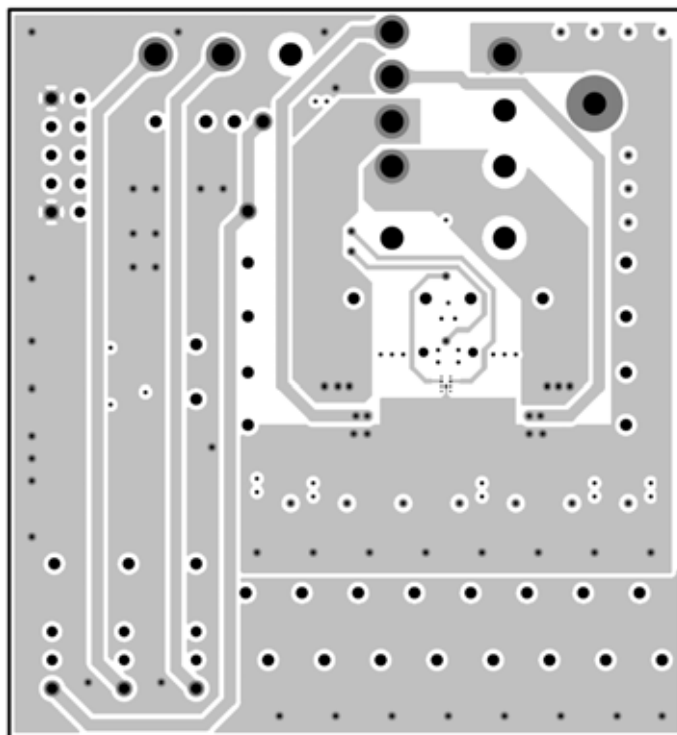

Figure 15. Layer 3 (Top View)

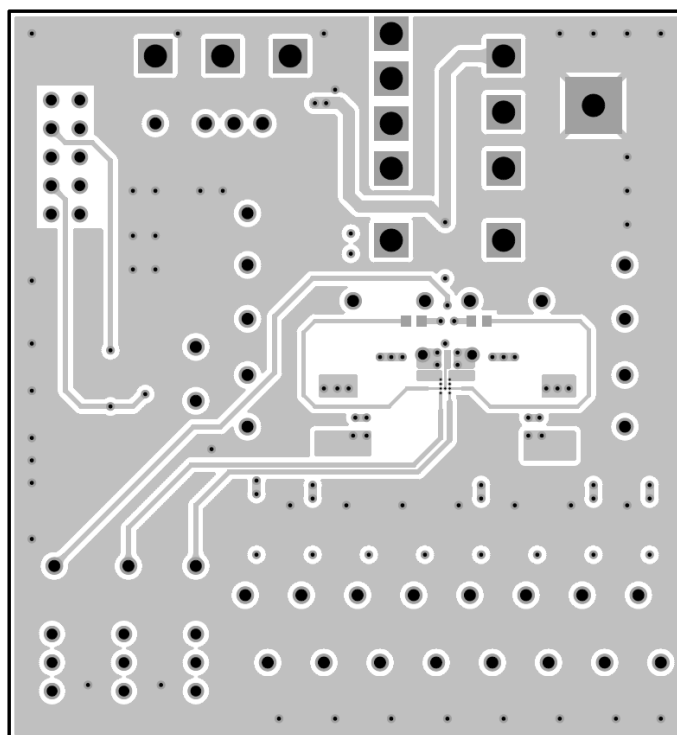

Figure 16. Bottom Layer (Top View)

Note: The parameters above is subject to change for improvement without notice.

	2013-05-15	
	Revised	

Regulations No.	1824S02E	<h1>User's Guide for Evaluation Board</h1>	AN30182A-EVB	
			Total Pages	Page
			24	24

IMPORTANT NOTICE

1. When using the IC for new models, verify the safety including the long-term reliability for each product.
2. When the application system is designed by using this IC, please confirm the notes in this book.
Please read the notes to descriptions and the usage notes in the book.
3. This IC is intended to be used for general electronic equipment.
Consult our sales staff in advance for information on the following applications: Special applications in which exceptional quality and reliability are required, or if the failure or malfunction of this IC may directly jeopardize life or harm the human body. Any applications other than the standard applications intended.
 - (1) Space appliance (such as artificial satellite, and rocket)
 - (2) Traffic control equipment (such as for automotive, airplane, train, and ship)
 - (3) Medical equipment for life support
 - (4) Submarine transponder
 - (5) Control equipment for power plant
 - (6) Disaster prevention and security device
 - (7) Weapon
 - (8) Others : Applications of which reliability equivalent to (1) to (7) is required

Our company shall not be held responsible for any damage incurred as a result of or in connection with the IC being used for any special application, unless our company agrees to the use of such special application.
However, for the IC which we designate as products for automotive use, it is possible to be used for automotive.
4. This IC is neither designed nor intended for use in automotive applications or environments unless the IC is designated by our company to be used in automotive applications.
Our company shall not be held responsible for any damage incurred by customers or any third party as a result of or in connection with the IC being used in automotive application, unless our company agrees to such application in this book.
5. Please use this IC in compliance with all applicable laws and regulations that regulate the inclusion or use of controlled substances, including without limitation, the EU RoHS Directive. Our company shall not be held responsible for any damage incurred as a result of our IC being used by our customers, not complying with the applicable laws and regulations.
6. Pay attention to the direction of the IC. When mounting it in the wrong direction onto the PCB (printed-circuit-board), it might be damaged.
7. Pay attention in the PCB (printed-circuit-board) pattern layout in order to prevent damage due to short circuit between pins. In addition, refer to the Pin Description for the pin configuration.
8. Perform visual inspection on the PCB before applying power, otherwise damage might happen due to problems such as solder-bridge between the pins of the IC. Also, perform full technical verification on the assembly quality, because the same damage possibly can happen due to conductive substances, such as solder ball, that adhere to the IC during transportation.
9. Take notice in the use of this IC that it might be damaged when an abnormal state occurs such as output pin-VCC short (Power supply fault), output pin-GND short (Ground fault), or output-to-output-pin short (load short). Safety measures such as installation of fuses are recommended because the extent of the above-mentioned damage will depend on the current capability of the power supply.
10. The protection circuit is for maintaining safety against abnormal operation. Therefore, the protection circuit should not work during normal operation.
Especially for the thermal protection circuit, if the area of safe operation or the absolute maximum rating is momentarily exceeded due to output pin to VCC short (Power supply fault), or output pin to GND short (Ground fault), the IC might be damaged before the thermal protection circuit could operate.
11. Unless specified in the product specifications, make sure that negative voltage or excessive voltage are not applied to the pins because the IC might be damaged, which could happen due to negative voltage or excessive voltage generated during the ON and OFF timing when the inductive load of a motor coil or actuator coils of optical pick-up is being driven.
12. Product which has specified ASO (Area of Safe Operation) should be operated in ASO
13. Verify the risks which might be caused by the malfunctions of external components.
14. Due to the unshielded structure of this IC, functions and characteristics of the IC cannot be guaranteed under the exposure of light. During normal operation or even under testing condition, please ensure that the IC is not exposed to light.
15. Please ensure that your design does not have metal shield parts touching the chip surface as the surface potential is GND voltage.

	2013-05-15	
	Revised	

Request for your special attention and precautions in using the technical information and semiconductors described in this book

- (1) If any of the products or technical information described in this book is to be exported or provided to non-residents, the laws and regulations of the exporting country, especially, those with regard to security export control, must be observed.
- (2) The technical information described in this book is intended only to show the main characteristics and application circuit examples of the products. No license is granted in and to any intellectual property right or other right owned by Panasonic Corporation or any other company. Therefore, no responsibility is assumed by our company as to the infringement upon any such right owned by any other company which may arise as a result of the use of technical information described in this book.
- (3) The products described in this book are intended to be used for general applications (such as office equipment, communications equipment, measuring instruments and household appliances), or for specific applications as expressly stated in this book. Consult our sales staff in advance for information on the following applications:
 - Special applications (such as for airplanes, aerospace, automotive equipment, traffic signaling equipment, combustion equipment, life support systems and safety devices) in which exceptional quality and reliability are required, or if the failure or malfunction of the products may directly jeopardize life or harm the human body.It is to be understood that our company shall not be held responsible for any damage incurred as a result of or in connection with your using the products described in this book for any special application, unless our company agrees to your using the products in this book for any special application.
- (4) The products and product specifications described in this book are subject to change without notice for modification and/or improvement. At the final stage of your design, purchasing, or use of the products, therefore, ask for the most up-to-date Product Standards in advance to make sure that the latest specifications satisfy your requirements.
- (5) When designing your equipment, comply with the range of absolute maximum rating and the guaranteed operating conditions (operating power supply voltage and operating environment etc.). Especially, please be careful not to exceed the range of absolute maximum rating on the transient state, such as power-on, power-off and mode-switching. Otherwise, we will not be liable for any defect which may arise later in your equipment.

Even when the products are used within the guaranteed values, take into the consideration of incidence of break down and failure mode, possible to occur to semiconductor products. Measures on the systems such as redundant design, arresting the spread of fire or preventing glitch are recommended in order to prevent physical injury, fire, social damages, for example, by using the products.
- (6) Comply with the instructions for use in order to prevent breakdown and characteristics change due to external factors (ESD, EOS, thermal stress and mechanical stress) at the time of handling, mounting or at customer's process. When using products for which damp-proof packing is required, satisfy the conditions, such as shelf life and the elapsed time since first opening the packages.
- (7) This book may be not reprinted or reproduced whether wholly or partially, without the prior written permission of our company.