



# **DigiView User's Guide**

© 2012 TechTools

# DigiView User's Guide

© 2012 TechTools

All rights reserved. No parts of this work may be reproduced in any form or by any means - graphic, electronic, or mechanical, including photocopying, recording, taping, or information storage and retrieval systems - without the written permission of TechTools except for the purpose of enhancing the operation of the product by the end user, informing other prospective users of the product's features or for instructional benefit by the US Government or an educational institution.

While every precaution has been taken in the preparation of this document, TechTools assumes no responsibility for errors or omissions, or for damages resulting from the use of information contained in this document or from the use of programs and source code or hardware that may accompany it. In no event shall TechTools be liable for any loss of profit or any other commercial damage caused or alleged to have been caused directly or indirectly by this document.

Printed: January 2012 in Garland, Texas U.S.A.

## **Publisher**

*TechTools  
P.O. Box 462101  
Garland, TX 75046-2101  
U.S.A.*

## **Technical Sales**

*(972) 272-9392*

## **Fax**

*(972) 494-5814*

## **Email**

*Sales@tech-tools.com  
Support@tech-tools.com*

## **On The Web**

*www.tech-tools.com*

# Table of Contents

Foreword	0
<b>Part I Installing the Software</b>	<b>2</b>
1 Installing the USB Drivers .....	2
<b>Part II Configuration</b>	<b>5</b>
1 USB Connection .....	5
2 Connecting the Data Lines .....	6
3 Defining Signals and Triggers .....	7
<b>Signals</b> .....	<b>7</b>
Signal Editors.....	9
Boolean .....	11
Bus .....	12
Asynchronous .....	13
Analog .....	16
I2C .....	17
State .....	20
Synchronous .....	22
SPI Signal Properties.....	25
<b>Triggers</b> .....	<b>27</b>
Trigger Configuration .....	28
Match Types .....	31
Pattern Match .....	32
Edge Match .....	33
Stable Match .....	34
Equal Match .....	35
Not Equal Match.....	38
Greater Than Match.....	39
Greater Than or Equal Match.....	42
Less Than Match.....	43
Less Than or Equal Match.....	46
Sequencer .....	48
Trigger Selection Editor.....	49
4 Analyzer Options .....	49
5 Acquisition Options .....	53
6 Color Themes .....	55
7 Environment Settings .....	57
<b>Part III Capturing Data</b>	<b>61</b>
1 Hardware Status .....	63
2 Capture History .....	64
3 Capture Troubleshooting .....	68
<b>Part IV Navigating and Analyzing the Data</b>	<b>72</b>

1	Waveform Views .....	72
2	Using Markers .....	75
3	Marquee Zoom .....	79
4	Toolbar Buttons .....	79
5	Bird's-Eye View .....	81
6	Hot-Keys .....	82
7	Table View Windows .....	84
8	List View Windows .....	87
9	Using Link Groups .....	90
10	Searches .....	91
	Define Searches .....	91
	Searching .....	93
	Search Manager Windows .....	93
	Auto Search Windows .....	94
	Search Types .....	96
	Sequential Searches.....	97
	Pattern Searches.....	102
<b>Part V Window Arrangement</b>		<b>105</b>
1	Docking Windows .....	105
2	Tabbing Windows .....	106
	Tab Window Options .....	107
<b>Part VI Exporting</b>		<b>113</b>
1	Exporting All Signal Data .....	114
2	Exporting from List Windows .....	116
3	Exporting from Table Windows .....	117
<b>Part VII Printing</b>		<b>121</b>
1	Printing Options .....	122
2	JPEG Options .....	125
<b>Part VIII Creating, Saving and Restoring Project Files</b>		<b>129</b>
<b>Part IX Appendicies</b>		<b>132</b>
1	DigiView Compression .....	132
2	DigiView Hardware Specifications .....	135
	<b>Index</b>	<b>138</b>

# Installing the Software

**Part**

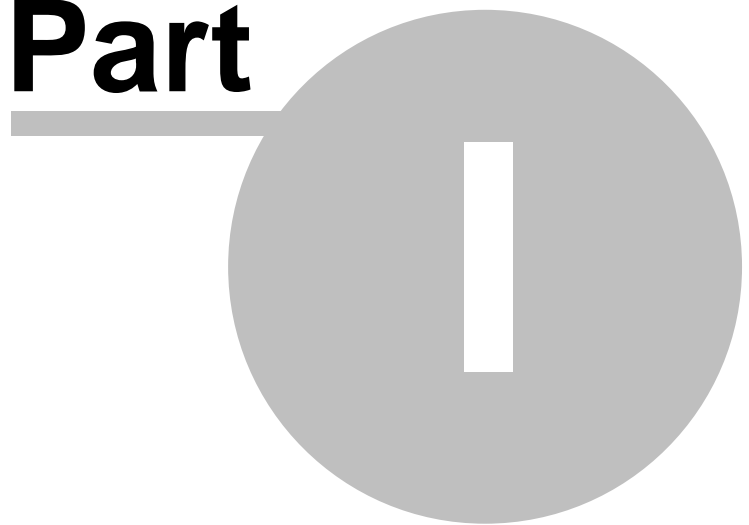

# 1 Installing the Software

Version 7.1 1/23/2012



Thank You for choosing TechTools for your development needs.

[www.tech-tools.com](http://www.tech-tools.com)

(972) 272-9392

[Email Support](#)

[Email Sales](#)

**Chances are that you already know this part but ...**

## ***Installing from CD ROM***

Insert the CD ROM in your CD Drive. If the installation program does not auto-start, then go to the CD ROM drive and dbl-click on the only executable file in the root directory of the CD. If you are presented with a choice of products, select the DIGIVIEW software and follow the prompts to complete the installation. All of the defaults offered are acceptable but you may over-ride any of them you want.

## ***Installing from a WEB Download***

If you downloaded the software from our web site, double-click on the file you downloaded to launch the self-extracting install program. Follow the prompts to install the software. All of the defaults offered are acceptable but you may over-ride any of them you want.

(see also: [Installing USB Drivers](#) <sup>(2)</sup>)

## 1.1 Installing the USB Drivers

We have 2 versions of the installer; the Current Release and a Legacy Release. The CURRENT RELEASE supports 32 and 64 bit versions of XP, Vista and Win7. The Legacy release supports Win98se, Win98Me and Win2K. It is available from our web site but is no longer updated or supported.

Our DigiView software and drivers are Authenticode signed.

**If Windows reports that the publisher is unknown or that the software is not signed, then the files are corrupt, infected or otherwise modified. Cancel the installation, delete the file and download an authentic copy from our web site: <http://www.tech-tools.com>.** The Authenticode signature is timestamped to ensure the signature remains valid even if our Certificate eventually expires. In other words, it will not 'time-out.' You will be able to re-install the software and drivers, even if we go out of business or fail to renew our certificate.

Run the application installer **BEFORE plugging in the hardware**. It installs the application software and pre-installs the drivers. You can accept the defaults or modify to suite your needs. Depending on your Windows version and system settings, Windows might ask your permission to install the application and again to install the drivers.

When the installation is complete, plug the DigiView into a high-speed USB port (preferably to a port directly connected to the motherboard at the rear of the computer or a port anywhere on the computer case that utilizes a high quality cable internally). Current versions of Windows will see the hardware and will find the pre-installed drivers automatically. Other versions will present a **Add New Hardware Wizard**.

Answer as follows for the smoothest installation:

**Win 7:**

No action needed.

**Vista:**

No action needed.

**XP:**

Search Windows Update? : "No,not at this time" (just saves time)  
"Install the software automatically" (the default)

**Win Me:**

"Specify the location of the driver"  
Select "Specify a location:" Then enter the path to the TechTools\drivers directory in the edit box. If you used the defaults during installation, this would be: "C:\Program Files\TechTools\DigiView\drivers"

**Win 98se:**

"Search for the best driver..."  
Select "Specify a location:" Then enter the path to the TechTools\drivers directory in the edit box. If you used the defaults during installation, this would be: "C:\Program Files\TechTools\DigiView\drivers"

If this is the first driver on your system to use the latest driver framework, Windows will take additional steps to update the system. Newer frameworks coexists with any older frameworks, ensuring that existing drivers continue to operate as before. Unfortunately, this takes Windows several minutes and requires a system reboot to complete. Note that this update occurs (if required) when you plug in the DigiView – not during our application install.

# Configuration

**Part**

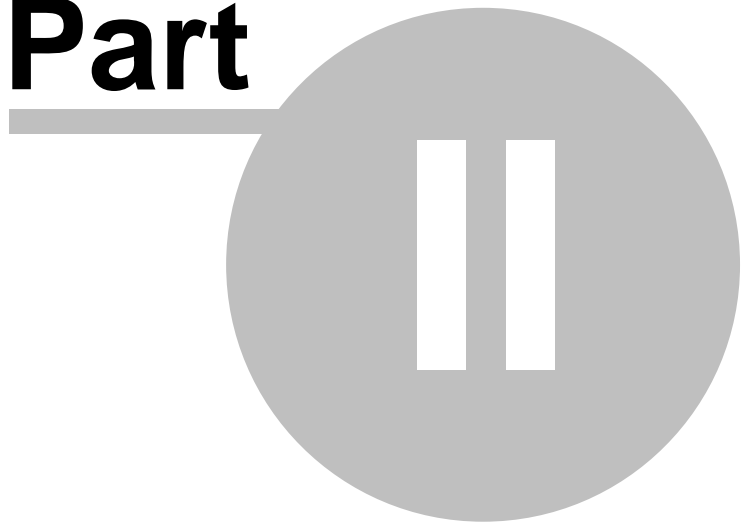



## 2 Configuration

The DigiView software is designed to make configuration an easy task and less time consuming than most PC based analyzer systems. The easier it is to configure and understand your Capture and Analysis tool, the easier it will be to achieve successful results.

Configuration options can be accessed by using the CONFIG menu.

After the hardware is connected to the PC, the first step of configuration is to attach the physical channels to the circuit and create a Signal definition that uses those channels.

The first topic in this section, after some brief USB information, covers the physical channel connections and cable color scheme. The next section provides detailed information on defining trigger conditions and associating a signal type with the physical channels. The remaining sections deal with user preferences.

[USB Connection](#) <sup>5</sup>

[Connecting Data Lines](#) <sup>6</sup>

[Defining Signals and Triggers](#) <sup>7</sup>

[Analyzer Options](#) <sup>49</sup>

[Acquisition Options](#) <sup>53</sup>

[Color Themes](#) <sup>55</sup>

[Environment Options](#) <sup>57</sup>

### 2.1 USB Connection

#### Power:

DV3100, DV3200:

Plug DigiView into a POWERED HUB (one with its own power supply) or directly into a USB port on your PC. You can not use a bus-powered hub; it does not have enough power to operate DigiView.

DV3400:

Powered by an external power supply, so USB power is of no concern.

#### Speed:

DV3100, DV3200, DV3400:

You will experience better performance on a 2.0 port, but a 1.1 port is sufficient.

#### Connection Quality:

Preferably, use a high-speed USB port located directly on the motherboard at the rear of the computer or a port anywhere on the computer case that utilizes a high quality cable internally. If

you use a different USB cable than the one provided with the unit, it should match the full rated speed of the USB connection to prevent communication errors or loss of data.

## 2.2 Connecting the Data Lines

The DigiView data cable has 18 data lines and 2 grounds (or 9 data lines and 1 ground on some models). These are partitioned into 2 identical groups. **Each group has a ground and 9 data signals.** The leads are color-coded. Black is ground, brown is the first data signal, red is the second data signal and so on in standard resistor color-code order. Additional groups of signals follow the same pattern.

The images below show the physical layout of the cable, data line definitions and color codes on various models. This figure is available by clicking the PINOUT button in the "[Edit Triggers & Signals](#)" window (selected from the CONFIG menu). This opens a non-modal window so you can leave it open while you work if desired.

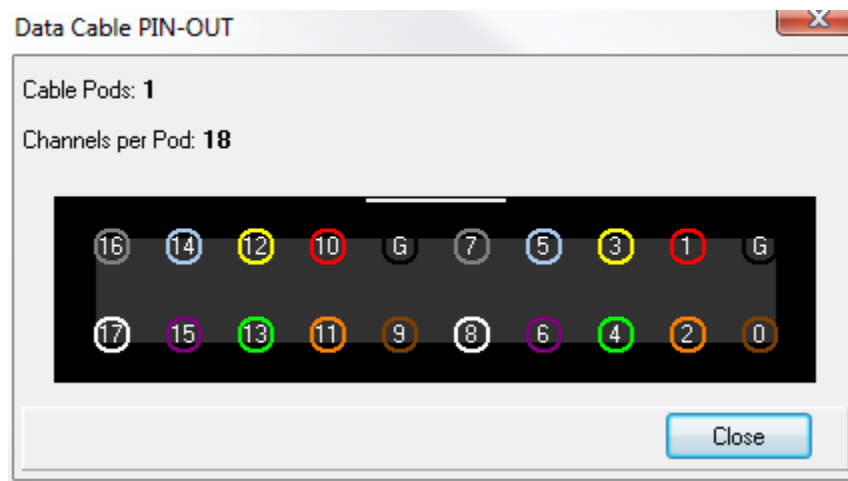

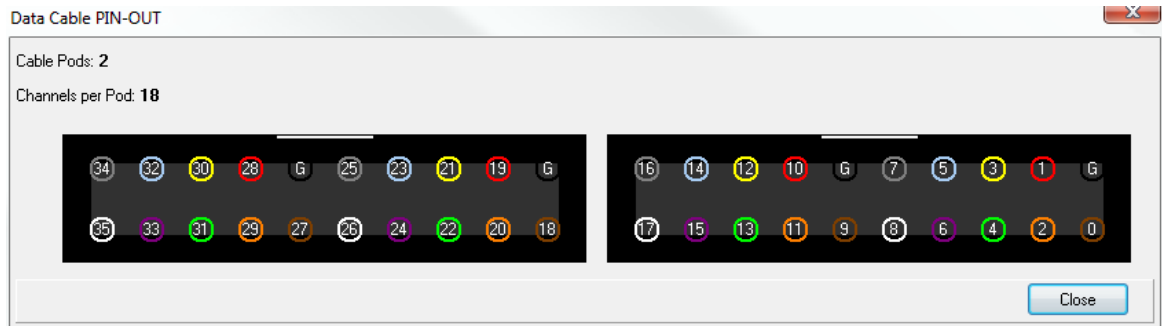

The data cable is made of high quality, extremely flexible wire and high quality connectors. It is expensive, so please remember to pull on the connectors; not the wires.

The connectors are designed to mate to .025 square posts and can be side-stacked on 100mil centers, making them ideal for direct connection to standard square post connectors. Additionally, they mate firmly with the included micro-grabber hooks for connecting to IC leads.

DigiView Models DV3100 and DV3200 are designed for signals in the -20 to 20V range and Model DV3400 is designed for signals in the -50 to 50V range. Standard overshoots and undershoots common to digital systems will not harm it. **The data lines have extra static protection circuits, current limits and impulse suppression.** However, mishandling could still damage them.

Simply treat them like you (should) treat your valuable one-of-a-kind target and DigiView will give you years of service.

## 2.3 Defining Signals and Triggers

The hardware will ignore any data lines that are not defined as part of a waveform or part of a trigger. This prevents unused signals from eating up the sample buffer space, even if they are connected to active signals. Waveforms that are defined but disabled will not be displayed, but may still be captured if the signal's definition includes a channel that is in use by another signal definition.

[Signals](#) <sup>7</sup>

[Triggers](#) <sup>27</sup>

### 2.3.1 Signals

Current DigiView hardware has either 18 or 36 physical channels. However, we like to think in terms of symbolic names representing individual signals (clock,ALE) or groups of signals (DataBus, Address) rather than channel numbers(0,1,2..). We start by defining SIGNALS in terms of CHANNELS. This is the only place we deal directly with physical channels. The remainder of the software deals in terms of signal names rather than channel numbers. When we define signals, we are mapping a signal NAME to one or more physical channels. This also makes it possible to share the same physical channel with multiple signal definitions (see: [Signal Editors](#) <sup>9</sup>).

#### Adding Signals to the Project

To create a Signal, select "Config->Signals..." from the main menu, which will open the "Project Settings" window to the Signal Definition tab.

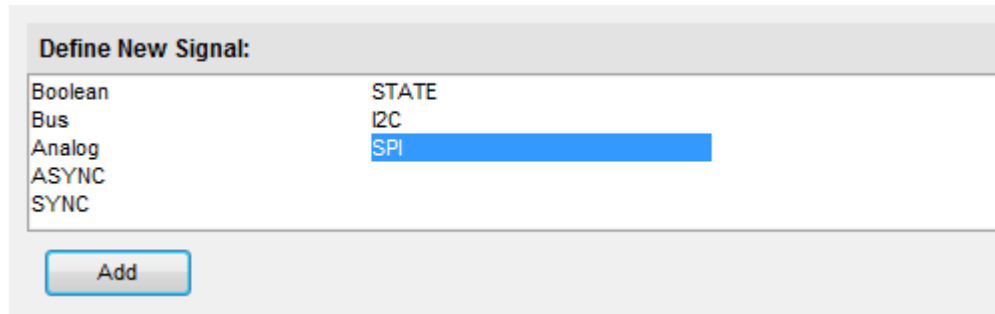

Double-Click on one of the "Define New Signal" selections to create a new signal or Highlight your choice and select "Add". A new signal of the chosen type will be created and its property editor will appear. You can rename the signal, change the physical channels to use for this signal definition and set all associated options from the signal's editor. (For details on signal options, see the section: [Signal Editors](#))

### Summary of the Project's Signals

The main purpose of the lower section of the config screen is to provide an overview of all current signal definitions and their related channels. You can also Edit or Delete signals from this section, determine each signal's type, its basic colors and its enabled status. The configuration section is arranged in a grid with columns representing the physical channels and one row per defined signal. Notice that the same channel can be assigned to multiple signal definitions. In the image below, channel 0 has been assigned to the Bus, STATE, Analog and STATE[1] signal definitions.

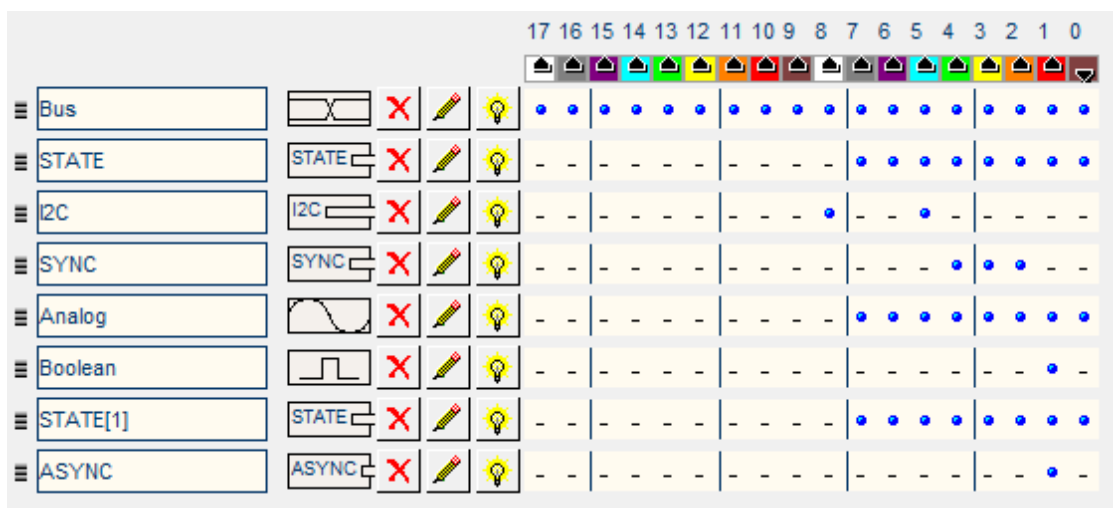

Channel 0 is in the farthest right column and channel 17 (or 35) is in the farthest left column (as marked in the header.) Light blue lines appear every 4th channel (or nibble).

In addition to the color references at the top of the window, you can click on the 'Cable Connector Pinout' button at the bottom of the window to see a physical layout of the attached analyzer's channel connector, with color codes.

Note that it is important to enable only channels that are actually being connected to your circuit. The remaining, unconnected channels will be floating and will most likely pick up noise or power line hum. If enabled, these transitions will get stored, wasting storage space. It is also important to connect the black ground wires to your target's ground so that the analyzer and the target have a common ground reference.

### Changing the Signal order -

When adding a large number of signal definitions, you may want to change some of their positions to organize or group related signals. To change the display order, grab the small handle in the left margin with your mouse and drag the definition to a new position.

### Signal Name -

The name of this signal definition. This value can be changed by editing the signal's properties. (see: [Signal Editors](#) <sup>(9)</sup>)

### Signal Colors and Type -

, etc.

You can see the color of a signal and determine the type by this graphical indicator (displayed to the right of the name assigned to the signal). Each signal type will display a unique graphic with representative colors.

### Delete Signal -

You can delete a signal definition by clicking on the 'X'.

### Edit Signal Properties -

You can change the properties of a signal definition by clicking this button. (see: [Signal Editors](#) <sup>(9)</sup>)

### Enabled Status -

Indicates the enabled state of the signal. When the lightbulb is ON, the signal is enabled. Click this button to toggle the "enabled" status of the signal. This value can also be changed by editing the signal's properties. (see: [Signal Editors](#) <sup>(9)</sup>)

### Associated Channels -

All channels associated with this signal definition will be indicated in this display as a blue "dot". Channel 0 is in the farthest right column and channel 17 (or 35) is in the farthest left column (as marked in the header.) Light blue lines appear every 4th channel and non associated channels appear as '-' as a reference. Also, colored squares at the top show each channel's wire color. Notice that there are only 9 colors so the color sequence repeats (channels 0 and 9 are both brown - the color Black is used for ground connections).

## 2.3.1.1 Signal Editors

DigiView provides several "Signal" type definitions which allow unique methods of interpreting and

displaying the raw data captured on the logic channels. Each Signal type has a unique editor with relevant options for its type. From the editor you will also assign some of the physical logic channels to be used for this new signal definition. (see: [Signals](#)<sup>[7]</sup>, [Connecting Data Lines](#)<sup>[6]</sup>)

You may choose to repeat the use of some channels in multiple Signal definitions in order to interpret the data differently and gain a perspective that is relative to your current point of interest. This can be done easily by creating a new Signal using the definition with the properties you require. Using the same channels in multiple definitions will not have any effect on the actual capture, but can greatly increase your ability to analyze the data and present visual representation to others.

NOTE: For your convenience, the signal editors display a darker background on channels that are already assigned to other signals. However, the same channel can be assigned to as many signal definitions as you need. For instance, if you want to capture the Read and Write cycles of an SPI bus using separate signal definitions (instead of the combined read/write of the SPI signal type), you can create 2 Synchronous Serial signals and assign the same channel as the Clock for each definition.

The currently available Signal Types are listed below. Details of each type's properties are described in the following sections.

#### [Analog](#)<sup>[16]</sup>

Multiple channels combined to a single analog view.

#### [Asynchronous](#)<sup>[13]</sup>

Serial UART analysis, pre-selected and custom baud rates, channel inversion option, from 4 to 8 bit selectable, parity option, Framing options and Glitch filter.

#### [Boolean](#)<sup>[11]</sup>

Single channel viewing.

#### [Bus](#)<sup>[12]</sup>

Multi-channel viewing.

#### [I2C](#)<sup>[17]</sup>

Complete I2C protocol analysis. 7bit/10bit addressing, High Speed Mode Master Codes, General Call support, Glitch filter.

#### [SPI](#)<sup>[25]</sup>

Master/Slave data from two Synchronous Serial data channels using the SPI protocol.

#### [State](#)<sup>[20]</sup>

Filters multi-channel data by state of a single channel, selectable CLK/DATA inversion, selectable transition state of Rising/Falling/Both, Framing and timeout options, additional Select and Sync channel for filtering.

#### [Synchronous](#)<sup>[22]</sup>

From 1 to 32 bit protocols, suitable for SPI analysis, selectable CLK/DATA inversion, selectable Rising/Falling/Both clock edges, LSB/MSB selection, additional Select, Frame Sync and Field Sync channels for filtering and synchronizing.

2.3.1.1.1 Boolean

The Boolean Signal is the most common method of viewing captured data. Boolean Signals provide viewing of the logic level of a single channel at any given point in time.

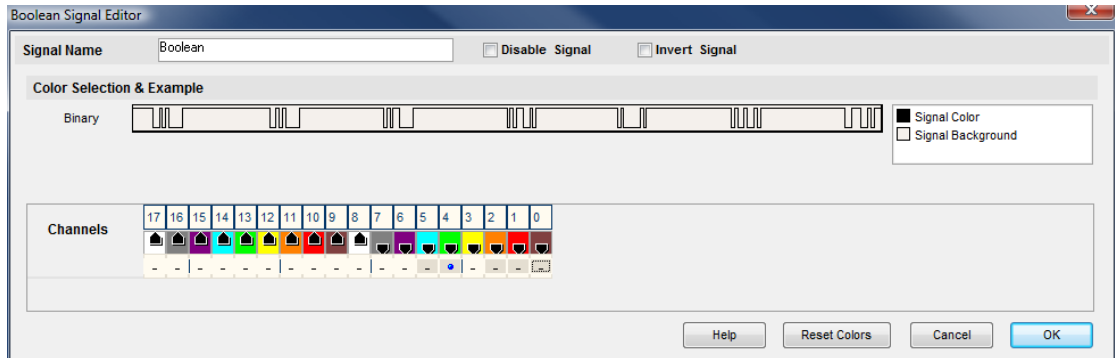

**Signal Name** - Change the text displayed here to help you identify this signal definition. If the name has already been used, it will automatically be appended with a numerical value in brackets (i.e. [2]). The name displayed here will be used in the Waveform Views, searches, tables, lists (if applicable), exports and all menu references.

**Color Selection & Examples** - If this signal definition has multiple Wave Form viewing modes, an example of each mode is displayed in the current color scheme, followed by a listing of any items that allow custom colors (i.e. Signal Color, Signal Background). Click on an item in the list to select a new color.

**Disable Signal** - Select (check) this item to completely disable the Signal Definition. It is recommended to disable any signals that use channels that are not connected to a physical device. When a capture takes place ("Run"), any channels that are assigned to disabled signals will be ignored instead of using valuable capture space.

**Invert Signal** - Check this item to have the value of the captured channels "inverted" before processing or displaying data for this signal definition. This setting will not effect any other signal definitions that may use the same channels.

**Channels** - This is where you will associate a signal definition with the physical channels or connections to the outside world. Each signal definition type will have one or more channel selection groups and will allow one or more channels to be selected for each group. Each channel selection group will be identified on its left if more than one group is available for the signal type.

To select a channel, click on the "-" below the proper color (and channel number) that corresponds to the physical connection of the DigiView Cable (see: [Connecting the Data Lines](#)<sup>[6]</sup>). Channels that are selected for this signal will replace the "-" with a blue "dot" as shown above. Channels that are already defined in other signal definitions will have a darker color around the selection area for the channel (as channels 0, 1, 2, 4 and 5 do in the graphic above).

**Reset Colors** - This button will reset the colors for this signal so that they will match the currently selected color theme (see: [Color Themes](#)<sup>[55]</sup>).

## 2.3.1.1.2 Bus

The Bus Signal is the second most common method of viewing captured data. Bus Signals provide viewing of multiple channels as a single value at any given point in time.

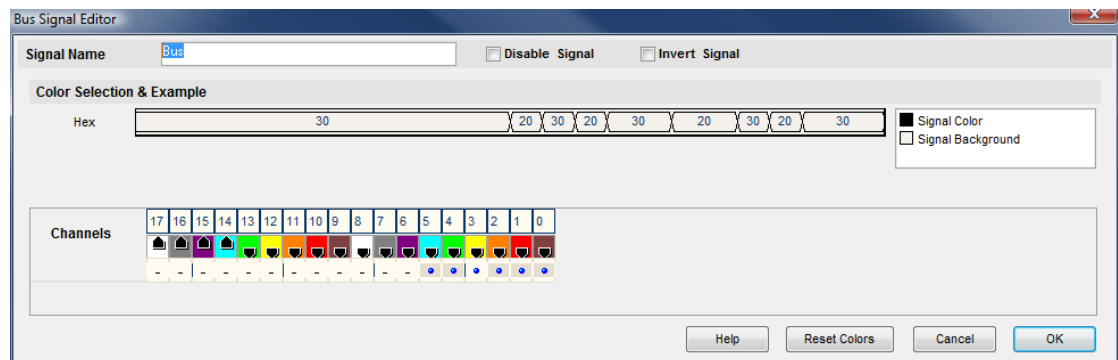

**Signal Name** - Change the text displayed here to help you identify this signal definition. If the name has already been used, it will automatically be appended with a numerical value in brackets (i.e. [2]). The name displayed here will be used in the Waveform Views, searches, tables, lists (if applicable), exports and all menu references.

**Color Selection & Examples** - If this signal definition has multiple Wave Form viewing modes, an example of each mode is displayed in the current color scheme, followed by a listing of any items that allow custom colors (i.e. Signal Color, Signal Background). Click on an item in the list to select a new color.

**Disable Signal** - Check this item to completely disable the Signal Definition. It is recommended to disable any signals that use channels that are not connected to a physical device. When a capture takes place ("Run"), any channels that are assigned to disabled signals will be ignored instead of using valuable capture space.

#### Invert Signal

This item is de-selected (unchecked) by default. Check this item to have the value of the captured channels "inverted" before processing or displaying for this signal definition. This setting will not effect any other signal definitions that may use the same channels.

#### Channels

This is where you will associate a signal definition with the physical channels or connections to the outside world. Each signal definition type will have one or more channel selection groups and will allow one or more channels to be selected for each group. Each channel selection group will be identified on its left if more than one group is available for the signal type.

To select a channel, click on the "-" below the proper color (and channel number) that corresponds to the physical connection of the DigiView Cable (see: [Connecting the Data Lines](#)). Channels that are selected for this signal will replace the "-" with a blue "dot" as shown above. Channels that are already defined in other signal definitions will have a darker



color around the selection area for the channel (as channels 0, 1, 2, 4 and 5 do in the graphic above).

**Reset Colors** - This button will reset the colors for this signal so that they will match the currently selected color theme (see: [Color Themes](#) <sup>[55]</sup>).

2.3.1.1.3 Asynchronous

Use the Asynchronous Signal type to see the capture from a single channel decoded and displayed as serial characters or frames of characters with a specific bit count and baud rate.

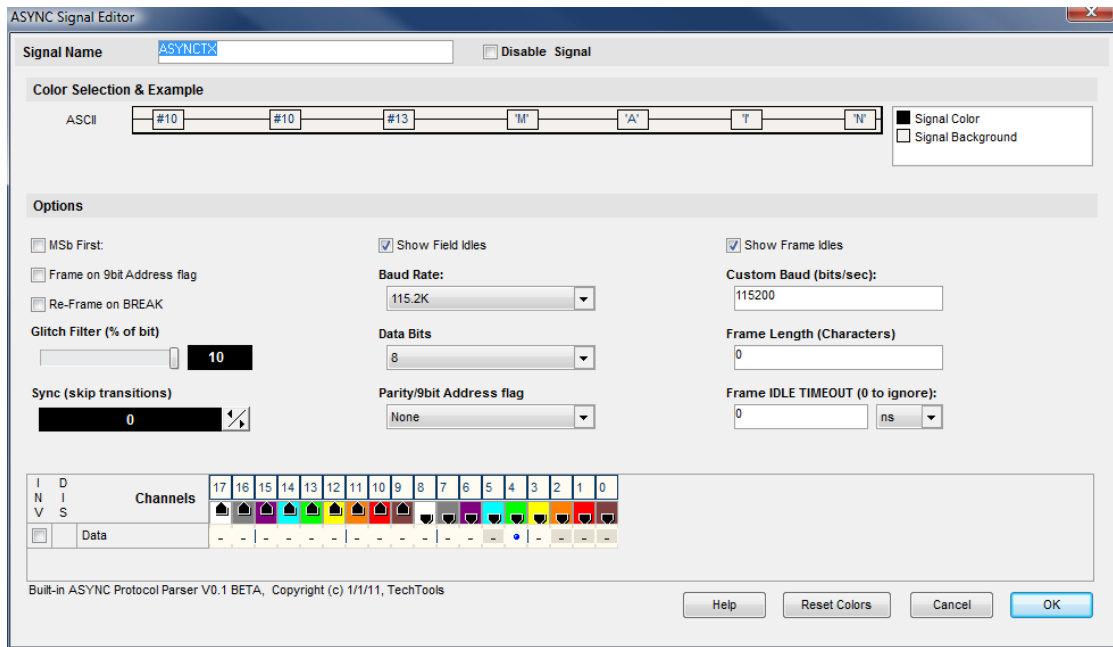

**Signal Name**

Change the text displayed here to help you identify this signal definition. If the name has already been used, it will automatically be appended with a numerical value in brackets (i.e. [2]). The name displayed here will be used in the Waveform Views, Searches, Tables, Lists, Exports and all menu references.

**Color Selection & Examples**

An example is displayed in the current color scheme, followed by a listing of any items that allow custom colors (i.e. Signal Color, Signal Background). Click on an item in the list to select a new color.

**Data**

Selects which physical channel to assign to the DATA bus.

**Baud Rate:**

Selects from a list of standard BAUD rates or 'use custom'.

**Custom Baud (bits/sec):**

The BAUD rate to use if BAUD RATE is set to 'use custom'.

**Data Bits**

Selects the number of data bits in a character.

**Parity/9bit Address flag**

Selects from odd,even,one,zero,non standard parity settings.  
Also allows selection of 9bit addressing mode with and address field flagged with a '1' or with a '0'.

**Glitch Filter (% of bit)**

Select noise filter setting of none-10% of a bit width.

**Sync (skip transitions)**

Specifies how many transitions to ignore at the start of the buffer.  
Useful for syncing up when capture starts mid-character.

**MSB First:**

Specifies that bits are received in MSB first order (VERY rare).

**Frame Length (Characters)**

Number of characters in a frame. Set to 0 to disable.

**Frame IDLE TIMEOUT (0 to ignore):**

A new frame is started if no characters are seen for more than the specified time.  
Set to 0 to disable. This can be useful if there are none of the other frame methods apply, but you can see a consistent pause before each frame starts.

**Frame on 9bit Address flag**

Start a new frame when a 9bit address byte is detected (if parity set to 9bit mode).

**Re-Frame on BREAK**

Terminate and start a new frame when BREAK detected.

**Show Field Idles**

Specifies whether idle time between fields should be shown as a hashed field or if the current field should just extend to the next field.

**Show Frame Idles**

Specifies whether idle time between frames should be shown as a single center line or if the current frame should just extend to the start of the next frame.

**Disable Signal Channels**

Check this item to completely disable the Signal Definition. It is recommended to disable any signals that use channels that are not connected to a physical device. When a capture takes place ("Run"), any channels that are assigned to disabled signals will be ignored instead of using valuable capture space.

**Channel Selection**

This is where you will associate a signal definition with the physical channels or connections to the outside world. Each signal definition type will have one or more channel selection groups and will allow one or more channels to be selected for each group. Each channel selection group will be identified on its left if more than one group is available for the signal type.

To select a channel, click on the " - " below the proper color (and channel number) that corresponds to the physical connection of the DigiView Cable (see: [Connecting the Data Lines](#)<sup>[67]</sup>). Channels that are selected for this signal will replace the " - " with a blue "dot" as shown above. Channels that are already defined in other signal definitions will have a darker color around the selection area for the channel (as channels 0, 1, 2 and 5 do in the graphic above).

**Reset Colors** - This button will reset the colors for this signal so that they will match the currently selected color theme (see: [Color Themes](#)<sup>[55]</sup>).

## Display Fields

### DATA

Field type used for most characters. Shows the received data

### Address

Field type used for 9 bit address bytes. Shows the received data

### BREAK

Field type used for break events. Prints the word BREAK

### ParityError

Field type used to display parity errors. Shows ' P '

### FrameError

Field type used to display character framing errors. Shows ' F '

**NOTE:** Multiple framing methods can be used at the same time. For example, you could use a frame length specifier and the frames will be broken into the specified lengths. If a timeout is specified, it will override and terminate a frame if the specified time is exceeded.

## 2.3.1.1.4 Analog

Use the Analog Signal type to see a group of channels shown as an analog type plot. For example, you could look at the output of an A/D as a graph rather than numbers in a bus format.

The chosen channels do not have to be consecutive. Any "skipped" channels in this definition will be ignored and the selected channels "packed" to form the bits of a single value. The lowest selected channel will be the least significant bit (LSB). In the graphic below, channel 0 is the LSB and channel 7 is the MSB.

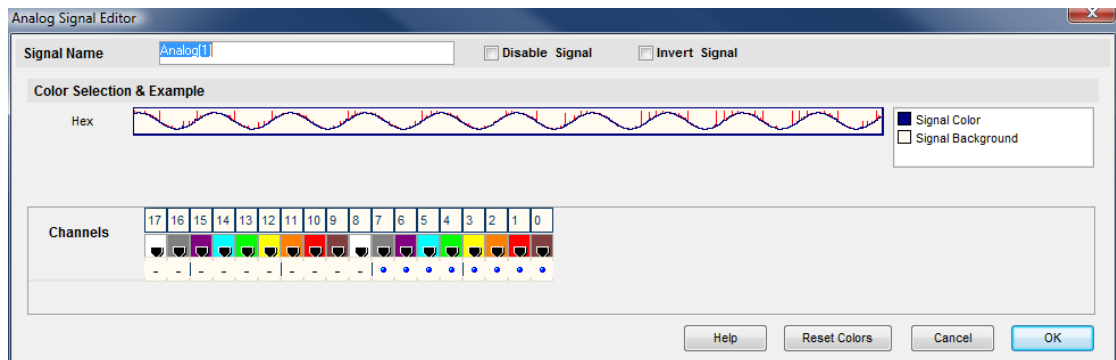

### Signal Name

Change the text displayed here to help you identify this signal definition. If the name has already been used, it will automatically be appended with a numerical value in brackets (i.e. [2]). The name displayed here will be used in the Waveform Views, Searches, Tables, Lists, Exports and all menu references.

### Disable Signal

Causes this signal to be ignored in future captures and in all current searches and displays windows.

### Invert Signal

Causes the channel to be logically inverted before being displayed.

### Color Selection & Examples

An example is displayed in the current color scheme, followed by a listing of any items that allow custom colors (i.e. Signal Color, Signal Background). Click on an item in the list to select a new color.

### Channel Selection

Selects which physical channels to assign to the signal. You can select two or more. They do not have to be contiguous. The total number of selected channels will become the bus width, regardless of which channels are selected. The highest numbered channel will be become the MSB and the lowest numbered channel will become the LSB (bit 0).

To select a channel, click on the "-" below the proper color (and channel number) that corresponds to the physical connection of the DigiView Cable (see: [Connecting the Data Lines](#)). Channels that are selected for this signal will replace the "-" with a blue "dot" as shown above. Channels that are already defined in other signal definitions will have a darker color around the selection area for the channel.

**Reset Colors** - This button will reset the colors for this signal so that they will match the currently selected color theme (see: [Color Themes](#)<sup>[55]</sup>).

2.3.1.1.5 I2C

Use the I2C Signal type to decode two channels using the full I2C serial protocol.

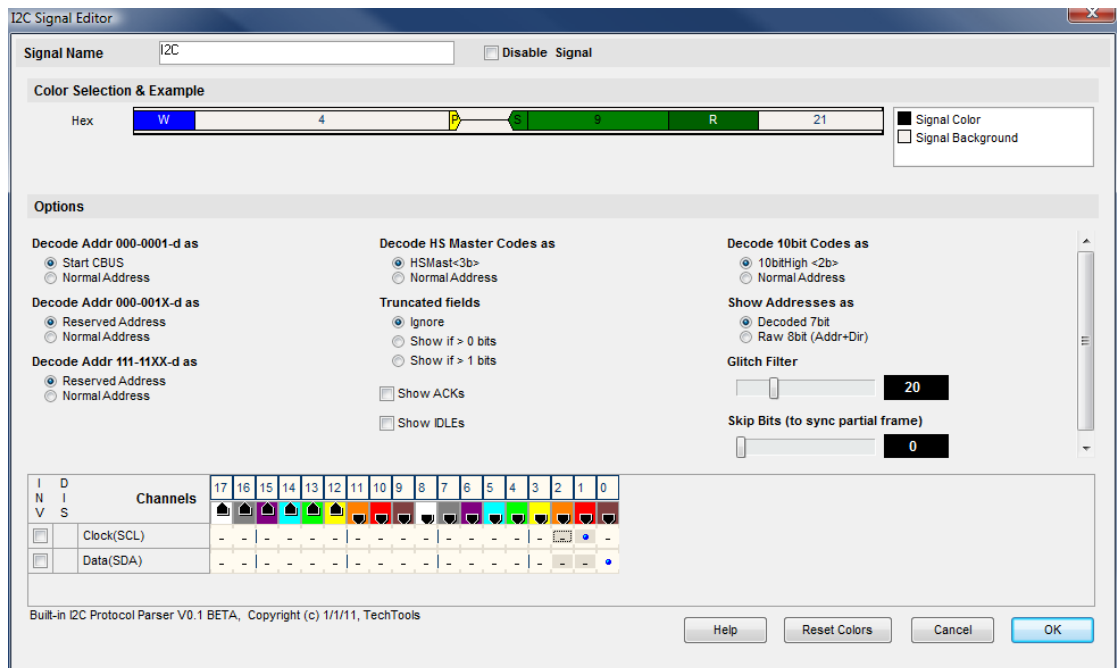

**Signal Name**

Change the text displayed here to help you identify this signal definition. If the name has already been used, it will automatically be appended with a numerical value in brackets (i.e. [2]). The name displayed here will be used in the Waveform Views, Searches, Tables, Lists, Exports and all menu references.

**Color Selection & Examples**

An example is displayed in the current color scheme, followed by a listing of any items that allow custom colors (i.e. Signal Color, Signal Background). Click on an item in the list to select a new color.

**Clock (SCL)**

Selects which physical channel to assign to the CLOCK.

**Data (SDA)**

Selects which physical channel to assign to the DATA bus.

**Glitch Filter**

Selects the amount of noise filtering. Should be set to 50ns for low speed buses and

reduces for FAST buses.

**Skip Bits (to sync partial frame)**

Specifies how many bits to ignore at the start of the buffer. Useful for syncing up when capture starts mid-frame.

**Decode Addr 000-0001-d as**

Selects between the standard I2C decoding for this address range or decoding it as normal 7 bit devices.

**Decode Addr 000-001X-d as**

Selects between the standard I2C decoding for this address range or decoding it as normal 7 bit devices.

**Decode Addr 111-11XX-d as**

Selects between the standard I2C decoding for this address range or decoding it as normal 7 bit devices.

**Decode HS Master Codes as**

Selects between the standard I2C decoding for this address range or decoding it as normal 7 bit devices.

**Decode 10bit Codes as**

Selects between the standard I2C decoding for this address range or decoding it as normal 7 bit devices.

**Truncated fields**

Specified whether to show truncated/partial fields or not. 1 bit truncated fields common and unavoidable so the options include showing only if > 1 bit.

**Show ACKs**

Selects whether to show ACKs in the waveforms, tables and searches NAKs are always shown.

**Show Addresses as**

The I2C spec defines 7 bit addresses and a 1 bit direction (R/W) in the first field. Sometimes it is convenient to think of this as a single 8 bit value. This option specifies whether to show as 2 fields (per spec.) or as a single 8 bit field.

**Show IDLEs**

Specifies whether idle time between fields should be shown as a hashed field or if the current field should just extend to the next field.

**Channel Selection**

This is where you will associate a signal definition with the physical channels or connections to the outside world. Each signal definition type will have one or more channel selection groups and will allow one or more channels to be selected for each group. Each channel selection group will be identified on its left if more than one group is available for the signal type.

To select a channel, click on the " - " below the proper color (and channel number) that corresponds to the physical connection of the DigiView Cable (see: [Connecting the Data Lines](#)<sup>[6]</sup>). Channels that are selected for this signal will replace the " - " with a blue "dot" as shown above. Channels that are already defined in other signal definitions will have a darker color around the selection area for the channel (as channels 1 and 2 do in the graphic

above).

### Reset Colors

This button will reset the colors for this signal so that they will match the currently selected color theme (see: [Color Themes](#)<sup>[55]</sup>).

## Display Fields

### Start

Field type used to show start and repeated start event.  
Shows ' S ' for start or ' Sr ' for repeated start.

### Stop

Field type used for stop events. Shows ' P '.

### Addr

Field type used for normal 7bit address fields

### Addr8

Field type used to show first byte as 8 bit address+direction

### Data

Field type used for most characters. Shows the received byte

### Ack

Field type used to show Acknowledge bit. Shows ' A '

### Nak

Field type used to show Nak bits. Shows ' N '.

### WRITE

Field type used to show WRITE bits. Shows ' W '.

### READ

Field type used to show READ bits. Shows ' R '.

### General-Call

Field type used to show first byte code is General-Call.  
Shows ' Gen-Call '

### Start-Byte

Field type used when the first byte code is START BYTE.  
Shows ' START '.

### HS Master

Field type used when first byte code is High Speed Master.  
Shows ' HS Master: ' followed by the 3 bit master ID

### CBUS

Field type used when the first byte code is CBUS.  
Prints the word CBUS.

### Reserved

Field type used when the first byte is a reserved address.

Prints the word 'RESERVED: ' followed by the actual data

### 10bitMode

Field type used when the first byte code is 10 bit Mode.

Prints ' 10bitMode: ' followed by the high 2 bits of the 10bit address.

### Truncated

Field type used when a byte is truncated (bt a stop or repeated start)

Prints ' T: ' followed by the received data.

#### 2.3.1.1.6 State

Use the State Signal type to see the data from one or more channels only when the state of another channel changes. This other channel will be used as a "state clock" and optionally the Clock can be qualified by the logic state of an additional channel (Enable). This signal type can be used to mask invalid data during bus transitional periods or the "noise" that occurs during unqualified periods, making it easier to analyze true data.

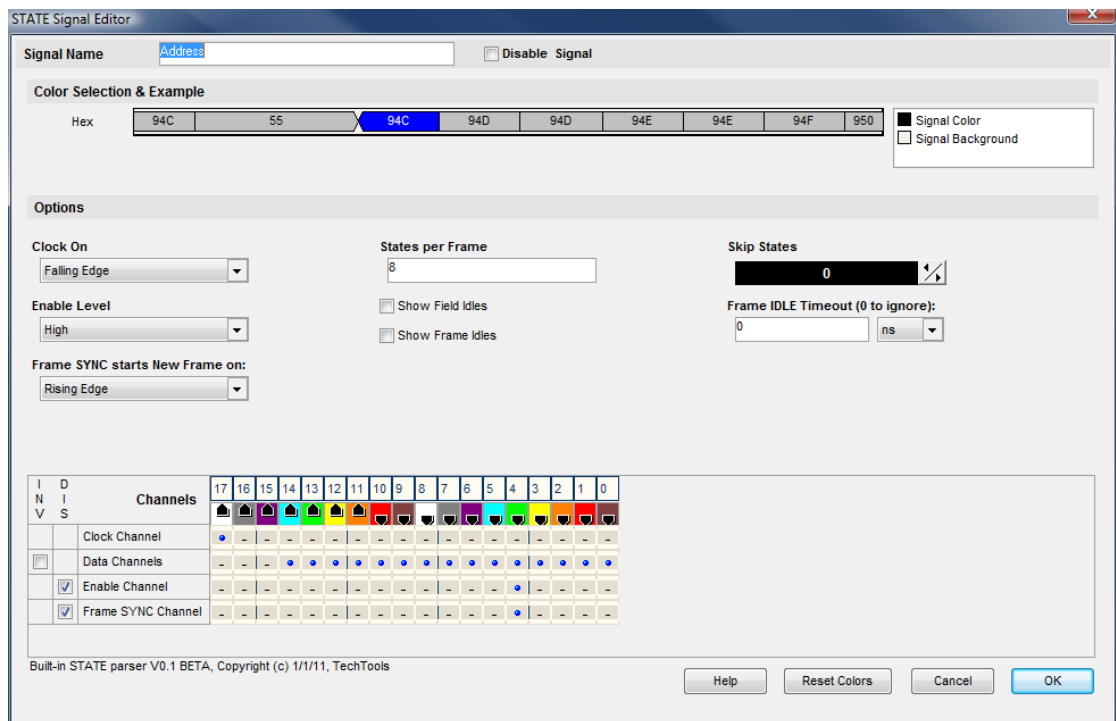

### Signal Name

Change the text displayed here to help you identify this signal definition. If the name has already been used, it will automatically be appended with a numerical value in brackets (i.e. [2]). The name displayed here will be used in the Waveform Views, Searches, Tables, Lists (if applicable), Exports and all menu references.

### Color Selection & Examples

An example is displayed in the current color scheme, followed by a listing of any items that



allow custom colors (i.e. Signal Color, Signal Background). Click on an item in the list to select a new color.

**Clock Channel**

Selects which physical channel to assign to the CLOCK.

**Data Channels**

Selects which physical channels to assign to the DATA bus.

**Enable Channel**

Selects which physical channel to assign to the ENABLE. The enable can be disabled if not used.

**Frame SYNC Channel**

Selects which physical channel to assign to the FRAME SYNC. The FRAME SYNC can be disabled if not used. This can be used to identify frame limits.

**Clock On**

Selects which edge of the clock to use to strobe in then data.

**Enable Level**

Selects the active level for the Enable signal.

**Skip States**

Specifies how many states to ignore before starting a frame. Useful for syncing up data that has no framing signals.

**States per Frame**

Specifies how many states are in a frame (if fixed). Set to 0 to ignore if other framing methods are being used.

**Frame SYNC starts New Frame on:**

Specifies how the Frame Sync signal is used (if enabled). Rising, Falling and Either edges specify what starts a new frame (and terminates the previous frame). The last two options specify that one edge starts a frame and the other edge terminates the frame. Any startframe will automatically end the previous frame. Specifying the endframe just ends it earlier for aesthetics.

**Frame IDLE Timeout (0 to ignore):**

A new frame is started if no new states are seen for more than the specified time. Set to 0 to disable. This can be useful if there are no sync lines or field counts but you can see a consistent pause before each frame starts.

**Show Field Idles**

Specifies whether idle time between fields should be shown as a hashed field or if the current field should just extend to the next field.

**Show Frame Idles**

Specifies whether idle time between frames should be shown as a single center line or if the current frame should just extend to the start of the next frame.

**Reset Colors**

This button will reset the colors for this signal so that they will match the currently selected color theme (see: [Color Themes](#)<sup>[55]</sup>).

**NOTE:** Multiple framing methods can be used at the same time. For example, you could use a frame length specifier and the frames will be broken into the specified lengths. If a timeout is specified, it will override and terminate a frame if the specified time is exceeded.

### 2.3.1.1.7 Synchronous

Use the Synchronous Signal type to see the data from a single channel decoded as a field of data or framed fields of data by using another channel as the bit clock. Optionally you can use the "Select" channel to qualify the clock.

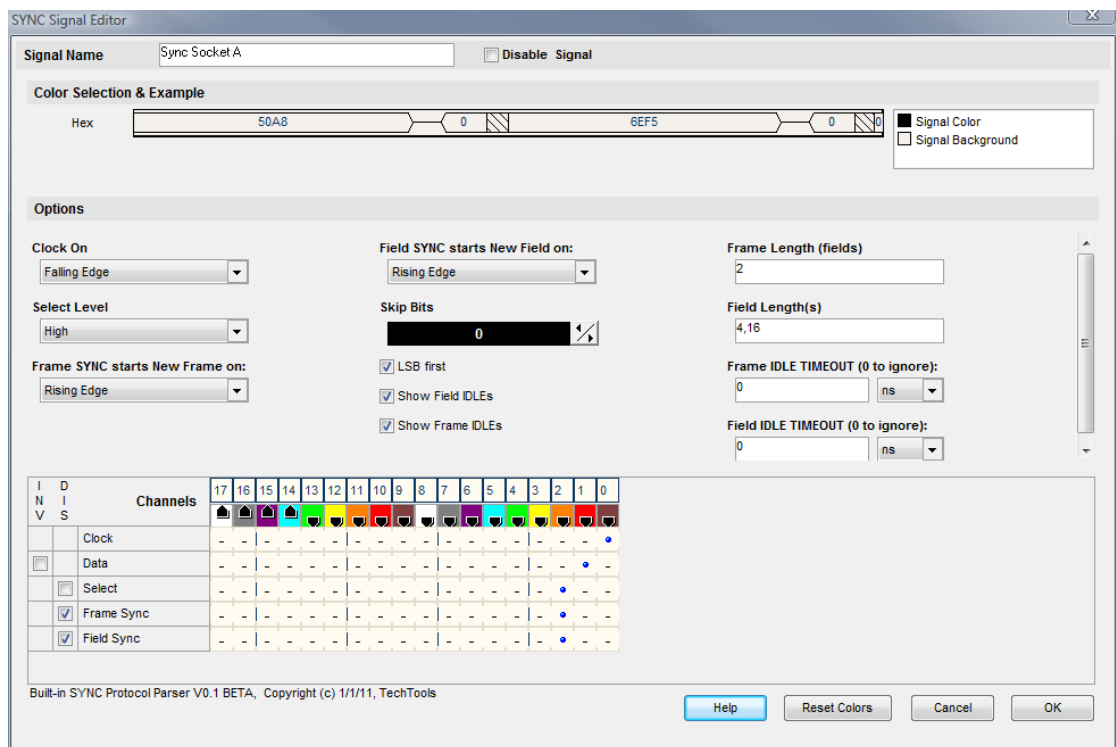

### Signal Name

Change the text displayed here to help you identify this signal definition. If the name has already been used, it will automatically be appended with a numerical value in brackets (i.e. [2]). The name displayed here will be used in the Waveform Views, Searches, Tables, Lists, Exports and all menu references.

### Color Selection & Examples

An example is displayed in the current color scheme, followed by a listing of any items that allow custom colors (i.e. Signal Color, Signal Background). Click on an item in the list to select a new color.

### Clock

Selects which physical channel to assign to the CLOCK.

**Data**

Selects which physical channel to assign to the DATA bus.

**Select:**

Selects which physical channel to assign to the ENABLE.  
The enable can be disabled if not used.

**Frame SYNC**

Selects which physical channel to assign to the FRAME SYNC.  
The FRAME SYNC can be disabled if not used. This can be used to identify frame limits.

**Field SYNC**

Selects which physical channel to assign to the FIELD SYNC.  
The FIELD SYNC can be disabled if not used. This can be used to identify field limits.

**Clock On**

Selects which edge of the clock to use to strobe in data.

**Select Level**

Selects the active level for the Select signal.

**LSB first**

Selects LSB (Least significant bit) first.

**Frame Length (fields)**

Specifies how many fields are in a frame.  
Set to 0 to disable this method of framing.

**Field Length(s)**

Specifies a list of comma separated field lengths (in bits).  
The first number is the length of the first field, the second number is the 2nd field and so forth. Set to 0 to disable this method of framing.

**Frame SYNC starts New Frame on:**

Specifies how the Frame Sync signal is used (if enabled). Rising, Falling and Either edges specify what starts a new frame (and terminates the previous frame). The last two options specify that one edge starts a frame and the other edge terminates the frame. Any startframe will automatically end the previous frame. Specifying the endframe just ends it earlier for aesthetics.

**Field SYNC starts New Field on:**

Specifies how the Field Sync signal is used (if enabled). Rising, Falling and Either edges specify what starts a new frame (and terminates the previous frame) The last two options specify that one edge starts a field and the other edge terminates it. Any startfield or start frame will automatically end the previous field. Specifying the endfield just ends it earlier for aesthetics.

**Frame IDLE TIMEOUT (0 to ignore):**

A new frame is started if no new bits are seen for more than the specified time. Set to 0 to disable. This can be useful if there are no sync lines or field counts but you can see a consistent pause before each frame starts.

**Field IDLE TIMEOUT (0 to ignore):**

A new frame is started if no new bits are seen for more than the specified time. Set to 0 to disable. This can be useful if there are no sync lines or field counts but you can see a

consistent pause before each frame starts.

**Skip Bits**

Specifies how many bits to ignore at the start of the buffer. Useful for syncing up when capture starts mid-field

**Show Field IDLEs**

Specifies whether idle time between fields should be shown as a hashed field or if the current field should just extend to the next field.

**Show Frame IDLEs**

Specifies whether idle time between frames should be shown as a single center line or if the current frame should just extend to the start of the next frame.

**NOTE:** Multiple framing methods can be used at the same time. For example, you could use a frame length specifier and the frames will be broken into the specified lengths. If a timeout is specified, it will override and terminate a frame if the specified time is exceeded.

**Reset Colors** - This button will reset the colors for this signal so that they will match the currently selected color theme (see: [Color Themes](#)<sup>[55]</sup>).

2.3.1.1.8 SPI Signal Properties

Use the SPI Signal type to see the Master/Slave data from two Synchronous Serial data channels using the SPI protocol.

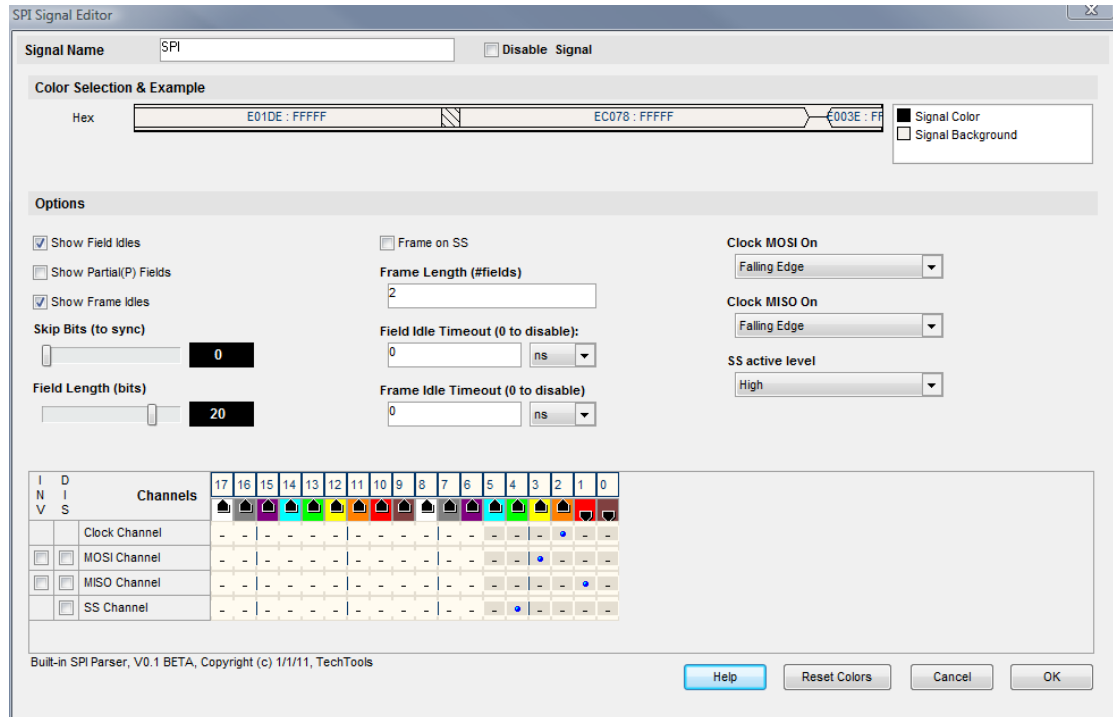

**Signal Name**

Change the text displayed here to help you identify this signal definition. If the name has already been used, it will automatically be appended with a numerical value in brackets (i.e. [2]). The name displayed here will be used in the Waveform Views, Searches, Tables, Lists (if applicable), Exports and all menu references.

**Color Selection & Examples**

An example is displayed in the current color scheme, followed by a listing of any items that allow custom colors (i.e. Signal Color, Signal Background). Click on an item in the list to select a new color.

**Clock Channel**

Selects which physical channel to assign to the CLOCK.

**MOSI Channel**

Selects which physical channel to assign to the MOSI data.

**MISO Channel**

Selects which physical channel to assign to the MISO data

**SS Channel**

Selects which physical channel to assign to SS (slave select)

**Clock MOSI On**

Specifies which clock edge to use to strobe in MOSI data.

**Clock MISO On**

Specifies which clock edge to use to strobe in MISO data

**SS active level**

Specifies the active level for the SS (slave select) signal

**Field Idle Timeout (0 to disable)**

A new field is started if no new bits are seen for more than the specified time. Set to 0 to disable.

**Skip Bits (to sync)**

Specifies how many bits to ignore at the start of the buffer. Useful for syncing up when capture starts mid-field

**Field Length (bits)**

Specifies the data field length from 4 to 24 bits.

**Show Field Idles**

Specifies whether idle time between fields should be shown as a hashed field or if the current field should just extend to the next field.

**Show Partial(P) Fields**

Specifies whether to show partial fields or not. Partial fields were terminated (by timeout or SS) before they gathered the full bit count.

**Show Frame Idles**

Specifies whether idle time between frames should be shown as a single center line or if the current frame should just extend to the start of the next frame.

**Frame Length (#fields)**

Specifies the number of fields to include in a frame (if fixed length).  
Set to 0 to disable.

**Frame Idle Timeout (0 to disable)**

A new frame is started if no new bits are seen for more than the specified time. Set to 0 to disable. This can be useful if there are no sync lines or field counts but you can see a consistent pause before each frame starts.

**Frame on SS**

Specifies that we should terminate a frame on SS disable edges and start a new frame on SS active edges.

**Display Fields****MOSI-MISO**

Field type used to show normal data.

Shows the both data channels, separated by a colon: ' MOSI : MISO '

**(P)MOSI-MISO**

Field type used to show partial (interrupted) data fields.

Shows '(P)' followed by both data channels, separated by a colon: ' (P)MOSI : MISO '.

**NOTE:** Multiple framing methods can be used at the same time. For example, you could use a frame length specifier and the frames will be broken into the specified lengths. If a timeout is specified, it will override and terminate a frame if the specified time is exceeded.

**Reset Colors** - This button will reset the colors for this signal so that they will match the currently selected color theme (see: [Color Themes](#)<sup>[55]</sup>).

### 2.3.2 Triggers

You can define a TRIGGER condition. When the hardware detects this condition, it will 'TRIGGER' the logic analyzer. When the sample buffer fills (or you manually STOP it), the data is transferred to the PC. The software on the PC then displays the data to you.

The trigger point is centered on the screen and is always TIME 0. All data prior to the trigger is negative time and all data after the trigger is positive time. If you stop the analyzer before a trigger condition is detected, the approximate center of the collected sample buffer is considered the trigger and the end of the data is the point where the hardware sampling was manually stopped.

**In our DigiView Software, triggers are specified in terms of SIGNALS.** After assigning channels to signal names ( see: [Signals](#)<sup>[7]</sup>), you can configure the trigger condition based on the defined signals. Most engineers will find it easier to reference the condition as it relates to the circuit's function rather than remembering which channels of the analyzer were used to connect to specific signals in the circuit.

DigiView's new trigger configuration screen centers the user's focus on function; making it much easier to quickly analyze and modify a very complex trigger condition. The following graphic is an example of an advanced trigger condition for the DV3 series.

(see: [Trigger Configuration](#)<sup>[28]</sup>, [Sequencer](#)<sup>[48]</sup>, [Trigger Selection Editor](#)<sup>[49]</sup> )

### Example of an Advanced Trigger Configuration for DV3400:

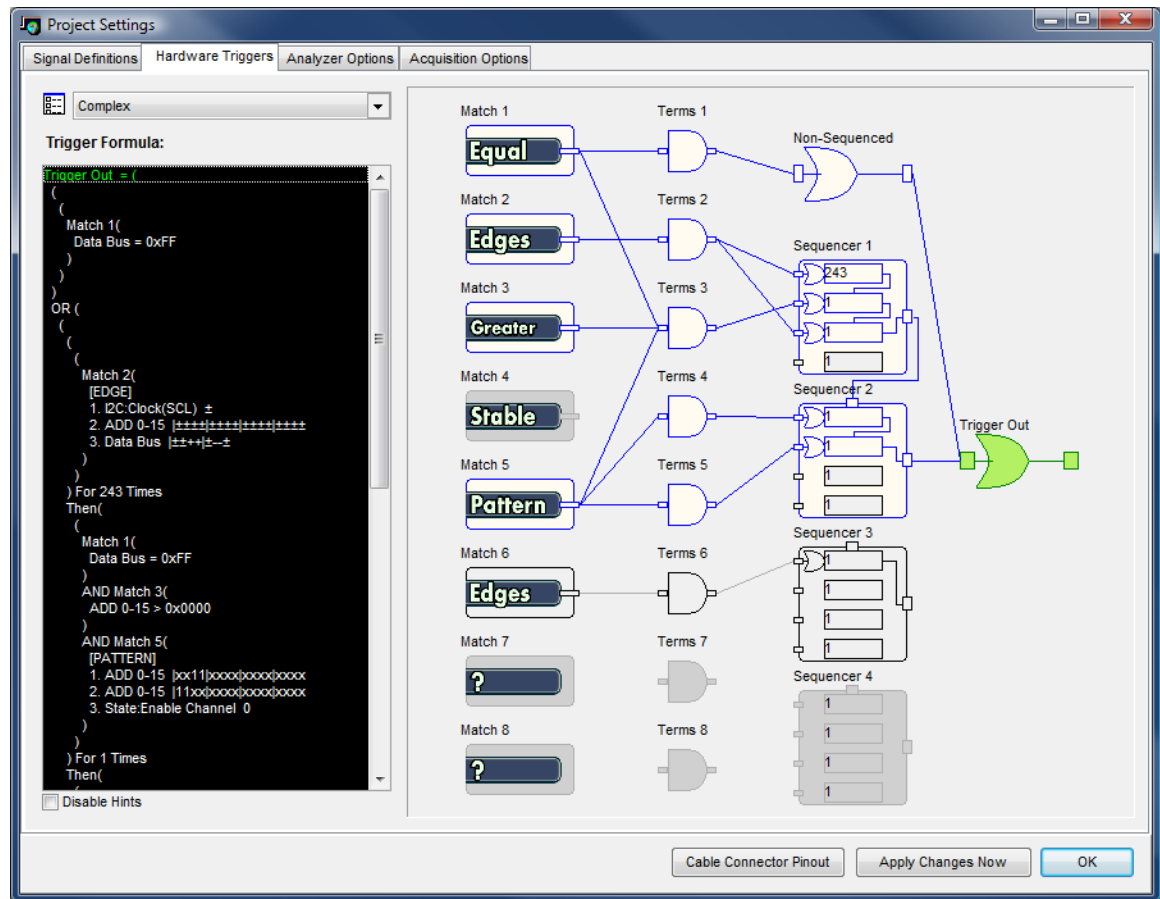

#### 2.3.2.1 Trigger Configuration

The new Trigger Configuration Screen introduces a dual-mode (GUI and text), schematic-like approach to configuring the matches, sequencers and trigger output from a single window. A text window shows the 'formula' for the configuration while the 'schematic' shows the flow. These two sections update together to provide two distinct views of the configuration. Multiple trigger configurations can also be selected and created using the selection area in the upper left corner of this screen.

#### Trigger Configuration Selection

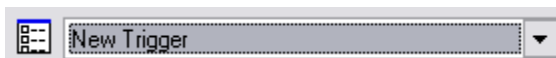

Multiple trigger configurations can be created and stored in the DigiView Data File. Use the selection box to quickly chose another trigger configuration. After making a selection, click the "apply" button on the bottom of the screen for



the changes to take affect. To create, copy or rename a configuration, use the icon to the left of the selection box to open the [Trigger Selection Editor](#)<sup>49</sup>.

**Trigger Formula** (left portion of screen)

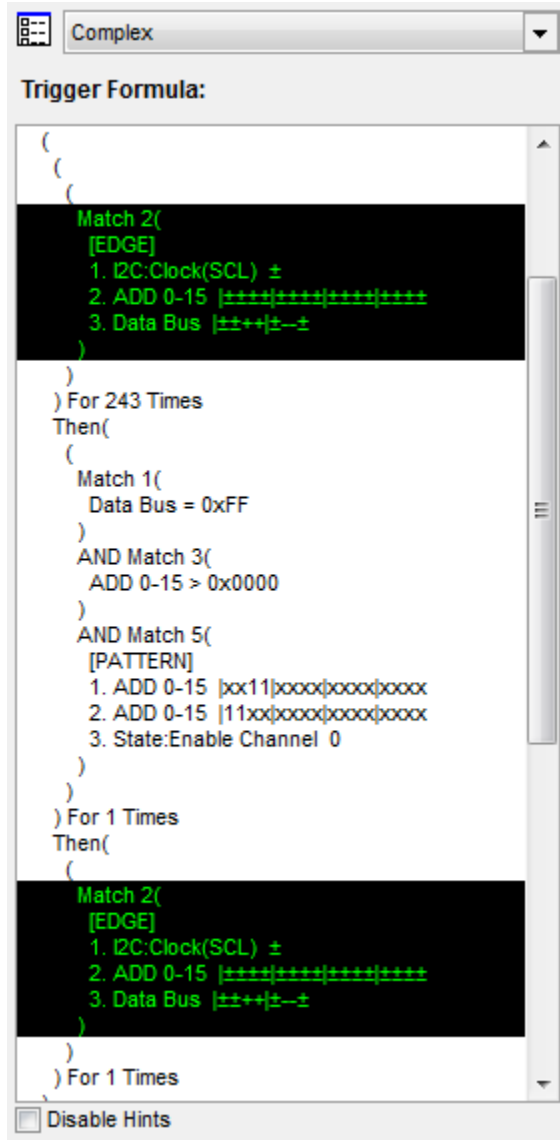

The formula presents a summary of the complete configuration. Since this summary can be quite involved with a complex trigger condition, each section will "highlight" as items in the graphical section are selected or the mouse moves over them. The formula will automatically scroll to bring the highlighted section into view while working in the graphical area of the configuration. In the image above, the summary of "MATCH 2" is brought into view as Match 2 is selected (shown in blue below).

**Schematic** (right portion of screen)

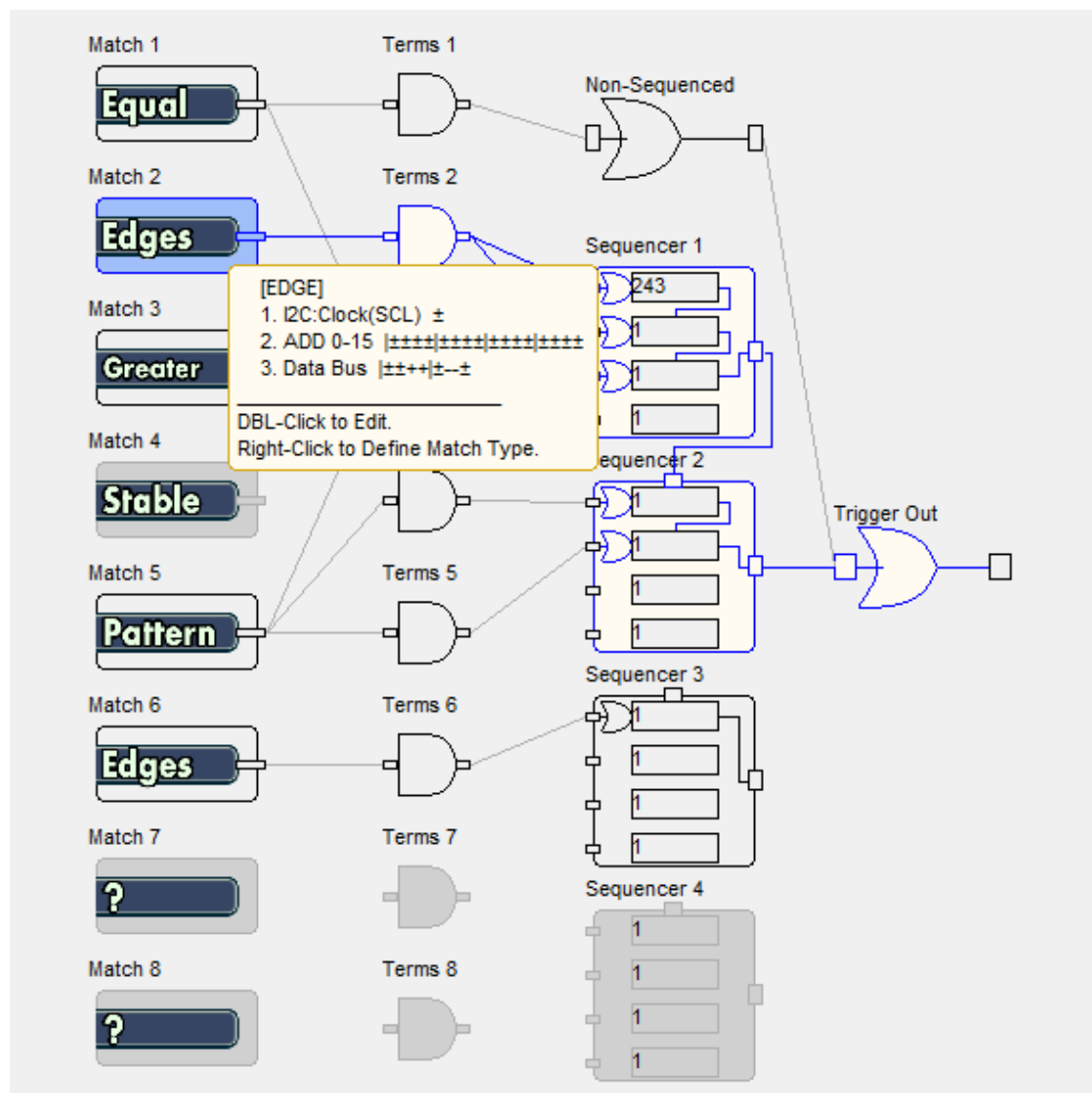

This area is where the actual configuration is accomplished.

Every trigger configuration starts with a match condition and ends with Trigger Out, so the work flow is designed from left to right, starting with the Match Types (see: [Match Types](#)<sup>[31]</sup>).

When the very first Match type is selected and the match condition has been specified, the match will automatically be routed graphically to the Trigger Out. For the DV3 series, this means it will route to TERMS 1, then the NON-Sequenced option and then to Trigger Out. This automatic function is only performed if no other connections already exist. Once you have started making connections for your trigger configuration, the software will not try to "guess" your intentions. Since this would hinder your work and cause aggravation, the software allows you to manually connect or disconnect if the action is valid. Only the obvious connect and disconnects will be performed automatically.

NOTE: The graphical connections in the trigger configuration directly correspond to the physical circuit connections in the hardware, making this screen an overview of the resulting

logic in the analyzer's hardware.

See the Following Sections:

- [Match Types](#) <sup>31</sup>
- [Sequencer](#) <sup>48</sup>

### 2.3.2.1.1 Match Types

The DigiView trigger configuration supports multiple types of Match conditions. The available match types depend on your model of analyzer. Details of each match type can be found using the links below.

DigiView DV3 series analyzers have a total of 8 configurable match circuits and each can be set to one of 9 different match types.

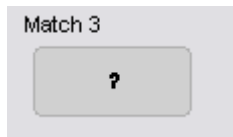

**Setting the Match Type** - A non-configured or "cleared" match will be identified by a "?" as seen above. To set the match type, simply click on the cleared match and select the type from the menu that appears.

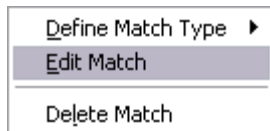

**Editing the Match Condition** - When selecting or changing the match type, the editor for the match condition will automatically appear. To edit the condition later, simply click on the match or right-click on the match and choose "Edit" from the menu that appears.

#### Available Match Types:

- [Pattern](#) <sup>32</sup>
- [Edges](#) <sup>33</sup>
- [Stable](#) <sup>34</sup>
- [Equal](#) <sup>35</sup>
- [Not Equal](#) <sup>38</sup>
- [Greater Than](#) <sup>39</sup>
- [Greater Than or Equal](#) <sup>42</sup>
- [Less Than](#) <sup>43</sup>
- [Less Than or Equal](#) <sup>46</sup>

(See: [Trigger Configuration](#) <sup>287</sup>)

#### 2.3.2.1.1.1 Pattern Match

The level trigger is a pattern match detector. You can configure it to match any combination of 0,1 or don't cares across all 18 (or 36) channels. The Pattern Match Editor is displayed below

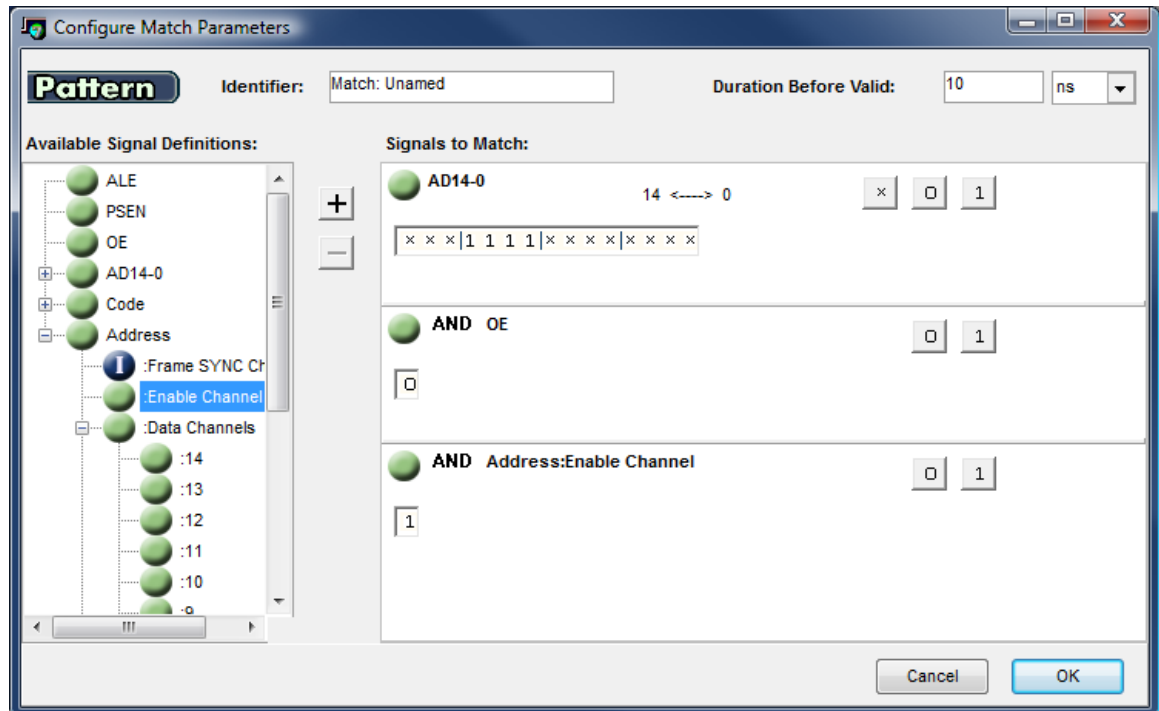

**ADD a Signal** - Highlight a defined signal from the left portion of the window and click the "+" button to add it to the Pattern Match. You can also just "Double-Click" the defined signal to automatically add it. NOTE: High Level signal definitions (such as State, I2C, or etc) cannot be added directly as a complete signal. However, the individual portions of the signal (such as Enable above) can be added in the same manner. To see the sub-portions of a signal, click the "expand" button in the left column next to the signal's name, then add the sub portions in the same manner as any other signal.

For instance, if you have defined a State signal like the one above (Address) and you only want to add the Enable signal to the pattern match, then expand it and double-click on Enable.

**Note:** If a signal is valid for the trigger configuration, a green icon will be displayed next to it. Any other icon, such as the blue circle above on the Frame Sync channel of the Address signal, indicates a channel state that is invalid for triggering. This particular icon indicates that the channel has been configured as 'Ignored' in the signal definition editor.

**Delete a Signal** - Highlight a signal in the right portion of the window (or mouse-over its bit selections) and click the "-" button to delete it from the Pattern Match.

**Changing Bit Pattern** - Each bit of the signal can be toggled between the 3 states of '0', '1' and 'x'

(don't care) by simply clicking on the bit position in the pattern edit area. To set all bits for a signal to one of these 3 values, use the X, 0 and 1 buttons to the upper-right of the pattern edit area.

**Identifier** - Change the identifier to something meaningful for the match condition if you do not want the default "Match #" to be displayed in the formula and the graphical configuration area of the trigger screen.

**Duration** - Enter the stability duration by selecting the units then typing the value. The Maximum Duration period for Model DV3200 and DV3400 is 5 ms; 10ms for Model DV3100. The Trigger condition will not be considered as "True" until the selected signals (and bits) match the pattern for the indicated duration period.

2.3.2.1.1.2 Edge Match

The edge trigger circuit is a 36 (or 72) input OR of rising edge and falling edge detectors. You can specify a trigger on rising, falling or transition on any combination of channels (rising edge of ALE or falling edge of OE or falling edge of WT or transition on clock...). All '-' entries for a channel means "don't care". The Edges Match Editor is displayed below

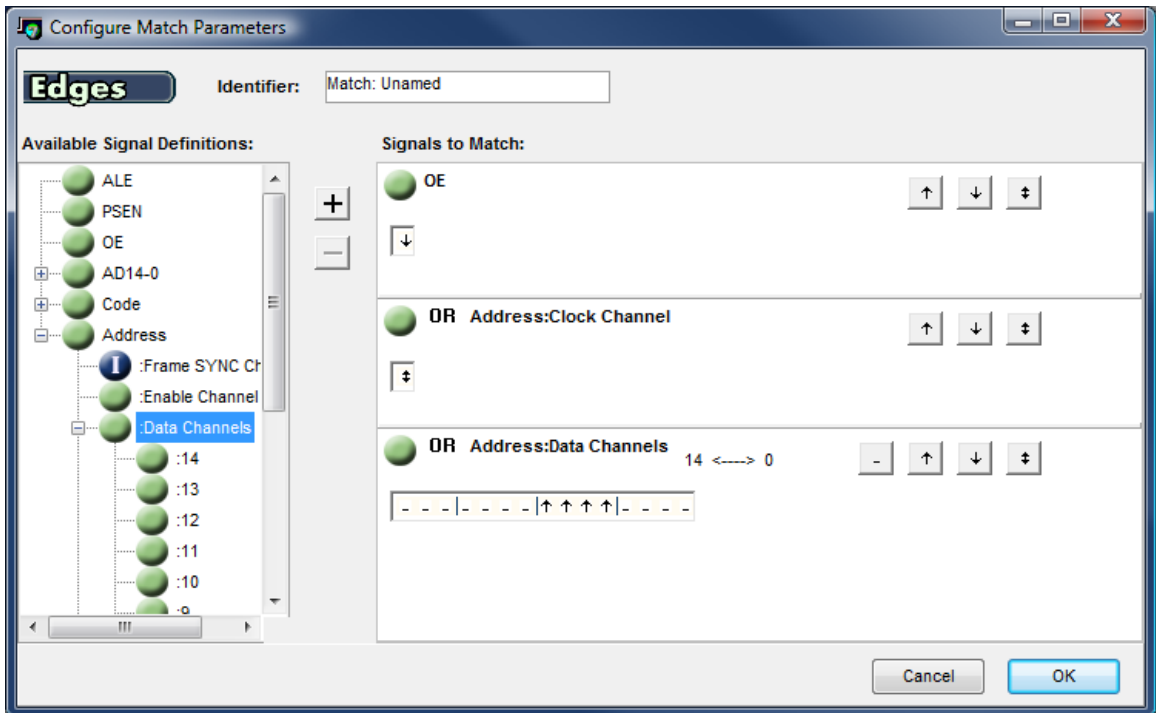

**ADD a Signal** - Highlight a defined signal from the left portion of the window and click the "+" button to add it to the Edges Match. You can also just "Double-Click" the defined signal to automatically add it. NOTE: High Level signal definitions (such as State, I2C, or etc) cannot be added directly as a complete signal. However, the individual portions of the signal (such as :CLK above) can be added in the same manner. To see the sub-portions of a signal, click the "expand" button in the left column next to the signal's name, then add the sub portions in the same manner as any other signal.

For instance, if you have defined a State signal like the one above (Address) and you only want to add the :CLK signal to the Edges match, then expand it and double-click on Enable.

**Note:** If a signal is valid for the trigger configuration, a green icon will be displayed next to it. Any other icon, such as the blue circle above on the Frame Sync channel of the Address signal, indicates a channel state that is invalid for triggering. This particular icon indicates that the channel has been configured as 'Ignored' in the signal definition editor.

**Delete a Signal** - Highlight a signal in the right portion of the window (or mouse-over its bit selections) and click the "-" button to delete it from the Edges Match.

**Changing Bit Pattern** - Each bit of the signal can be toggled between the 4 states of '-' (don't care), 'rising', 'falling' and 'either' by simply clicking on the bit position in the Edges edit area. To set all bits for a signal to one of these 4 values, use the buttons to the upper-right of the Edges edit area.

**Identifier** - Change the identifier to something meaningful for the match condition if you do not want the default "Match #" to be displayed in the formula and the graphical configuration area of the trigger screen.

#### 2.3.2.1.1.3 Stable Match

The Stable Match type is only available on DigiView DV3 series.

All '-' entries for a channel means "don't care". The Stable Match Editor is displayed below.

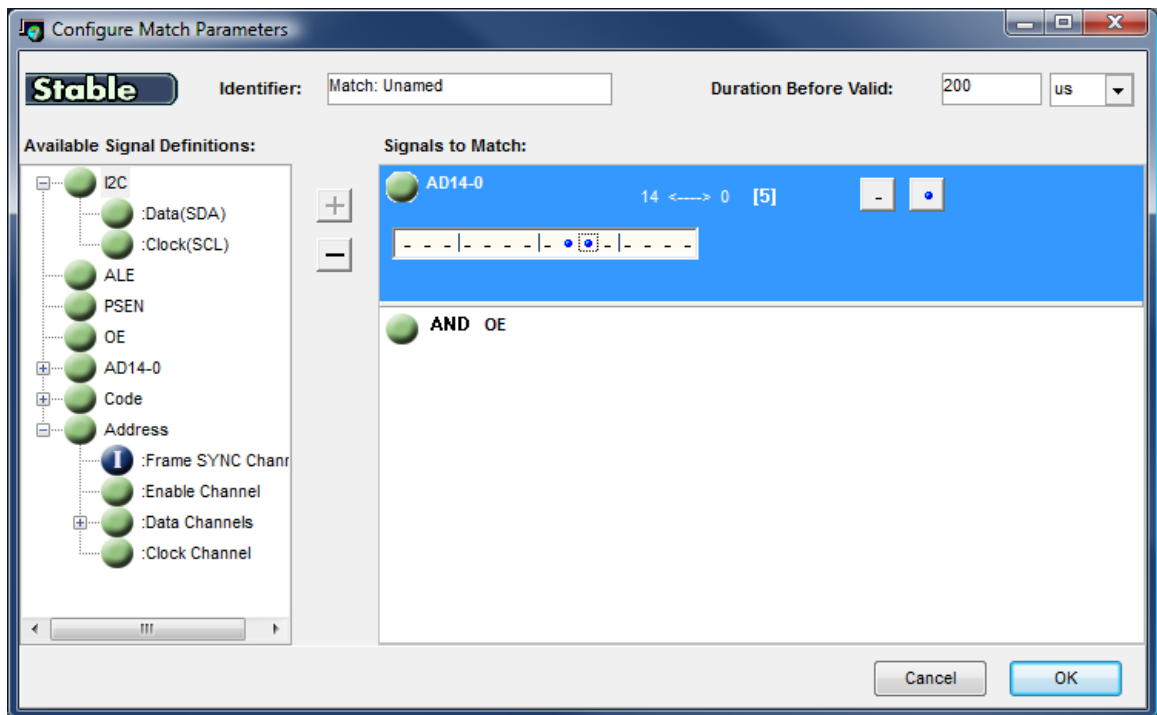

**ADD a Signal** - Highlight a defined signal from the left portion of the window and click the "+" button to add it to the Stable Match. You can also just "Double-Click" the defined signal to automatically add it. NOTE: High Level signal definitions (such as State, I2C, or etc) cannot be

added directly as a complete signal. However, the individual portions of the signal (such as :SCL above) can be added in the same manner. To see the sub-portions of a signal, click the "expand" button in the left column next to the signal's name, then add the sub portions in the same manner as any other signal.

For instance, if you have defined an I2C signal and you only want to add the clock (:SCL) signal to the Stable match, then expand it and double-click on :SCL. It would then appear on the right portion of the editor as "AND I2C:SCL" like the OE signal above.

**Note:** If a signal is valid for the trigger configuration, a green icon will be displayed next to it. Any other icon, such as the blue circle above on the Frame Sync channel of the Address signal, indicates a channel state that is invalid for triggering. This particular icon indicates that the channel has been configured as 'Ignored' in the signal definition editor.

**Delete a Signal** - Highlight a signal in the right portion of the window (or mouse-over its bit selections) and click the "-" button to delete it from the Stable Match.

**Selecting Stable bits** - Each bit of the signal can be toggled between the 2 states of '-' (don't care) and 'STABLE' by simply clicking on the bit position in the Stable edit area. To set all bits for a signal to one of these 2 values, use the buttons to the upper-right of the Stable edit area. Boolean signals, if added, do not offer a choice and should be removed when they are no longer needed as part of the Stable match.

**Duration** - Enter the stability duration by selecting the units then typing the value. The Maximum Duration period for Model DV3200 and DV3400 is 5 ms; 10ms for Model DV3100. The Trigger condition will not be considered as "True" until the selected signals (and bits) have been stable for the indicated duration period.

**Identifier** - Change the identifier to something meaningful for the match condition if you do not want the default "Match #" to be displayed in the formula and the graphical configuration area of the trigger screen.

#### 2.3.2.1.1.4 Equal Match

The Equal Match type is only available on DigiView DV3 series.

The Equal Match Editor:

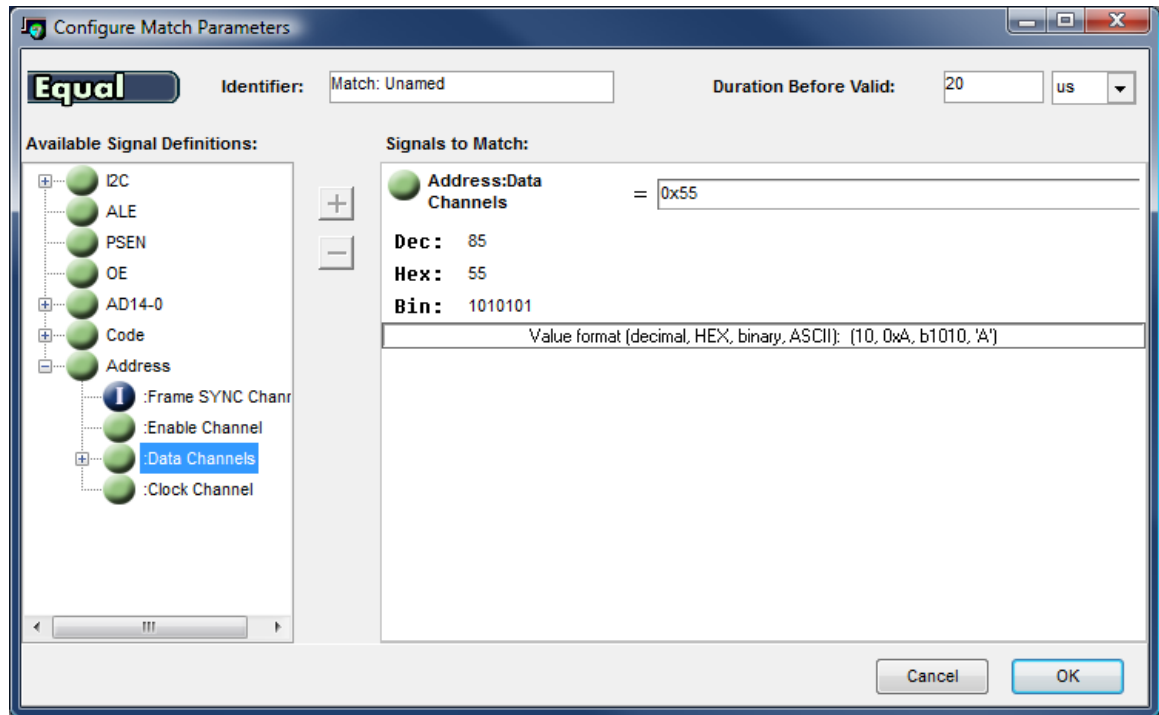

**ADD a Signal** - Highlight a defined signal from the left portion of the window and click the "+" button to add it as the Equal Match. You can also just "Double-Click" the defined signal to automatically add it. NOTE: High Level signal definitions (such as State, I2C, or etc) cannot be added directly as a complete signal. However, the individual portions of the signal (such as the 'Data Channels' portion of a State Signal) can be added in the same manner. To see the sub-portions of a signal, click the "expand" button in the left column next to the signal's name, then add the sub portion in the same manner as any other signal.

For instance, if you have defined an State signal and you want to add the Data portion of the signal to the Equal match, then expand it and double-click on :Data Channels. It would then appear on the right portion of the editor as shown above.

The Equal Match type only accepts one signal at a time. After a signal has been added, the "+" (ADD) button will be disabled (as shown above) until the current signal is removed.

**Note:** If a signal is valid for the trigger configuration, a green icon will be displayed next to it. Any other icon, such as the blue circle above on the Frame Sync channel of the Address signal, indicates a channel state that is invalid for triggering. This particular icon indicates that the channel has been configured as 'Ignored' in the signal definition editor.

**Delete a Signal** - Highlight a signal in the right portion of the window (or mouse-over its bit selections) and click the "-" button to delete it from the Equal Match.

**Match Value Format** - The value for the Equal Match type can be entered in Decimal, HEX, Binary or ASCII format. The value will be limited to the maximum value allowed for the selected signal, which will depend on the number of bit positions assigned to the signal. The formats for entering each value type is described below.

**Decimal:** Enter any valid decimal value. An Invalid value will be cleared to 0 or assumed to be



HEX.

**HEX:** Start the value with an "x" or a "0x". If too many digits are entered, the most significant nibble (leftmost) will be discarded. Any non-HEX digit will be ignored.

**Binary:** Enter "b" followed by "1's" and "0's". If too many digits are typed, the MSb (leftmost bit) will be discarded. Any numerical value larger than a "1" or non-numerical character will be considered a "1".

**ASCII:** Start the value with a single or double quote.

**Duration** - Enter the match duration by selecting the units then typing the value. The Maximum Duration period for Model DV3200 and DV3400 is 5 ms; 10ms for Model DV3100. The Trigger condition will not be considered as "True" until the entered value for the selected signal has been valid for the indicated duration period.

**Identifier** - Change the identifier to something meaningful for the match condition if you do not want the default "Match #" to be displayed in the formula and the graphical configuration area of the trigger screen.

## 2.3.2.1.1.5 Not Equal Match

The NOT Equal Match type is only available on DigiView DV3 series.

The NOT Equal Match Editor:

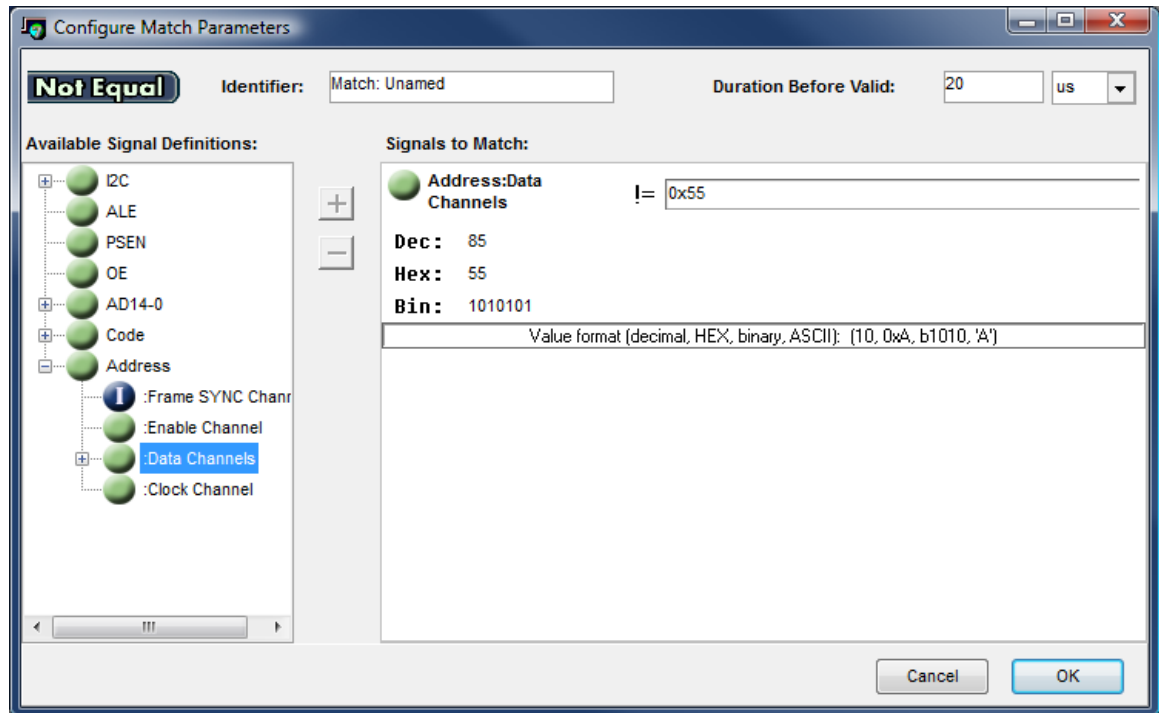

**ADD a Signal** - Highlight a defined signal from the left portion of the window and click the "+" button to add it as the NOT Equal Match. You can also just "Double-Click" the defined signal to automatically add it. NOTE: High Level signal definitions (such as State, I2C, or etc) cannot be added directly as a complete signal. However, the individual portions of the signal (such as the Data Channel portion of a State Signal) can be added in the same manner. To see the sub-portions of a signal, click the "expand" button in the left column next to the signal's name, then add the sub portion in the same manner as any other signal.

For instance, if you have defined a Synchronous Serial signal (i.e. SPI) and you want to add the :Enable portion of the signal to the NOT Equal match, then expand it and double-click on :Enable. It would then appear on the right portion of the editor.

The NOT Equal Match type only accepts one signal at a time. After a signal has been added, the "+" (ADD) button will be disabled (as shown above) until the current signal is removed.

**Note:** If a signal is valid for the trigger configuration, a green icon will be displayed next to it. Any other icon, such as the blue circle above on the Frame Sync channel of the Address signal, indicates a channel state that is invalid for triggering. This particular icon indicates that the channel has been configured as 'Ignored' in the signal definition editor.

**Delete a Signal** - Highlight a signal in the right portion of the window (or mouse-over its bit selections) and click the "-" button to delete it from the NOT Equal Match.

**Match Value Format** - The value for the Not Equal Match type can be entered in Decimal, HEX, Binary or ASCII format. The value will be limited to the maximum value allowed for the selected signal, which will depend on the number of bit positions assigned to the signal. The formats for entering each value type is described below.

**Decimal:** Enter any valid decimal value. An Invalid value will be cleared to 0 or assumed to be HEX.

**HEX:** Start the value with an "x" or a "0x". If too many digits are entered, the most significant nibble (leftmost) will be discarded. Any non-HEX digit will be ignored.

**Binary:** Enter "b" followed by "1's" and "0's". If too many digits are typed, the MSb (leftmost bit) will be discarded. Any numerical value larger than a "1" or non-numerical character will be considered a "1".

**ASCII:** Start the value with a single or double quote.

**Duration** - Enter the match duration by selecting the units then typing the value. The Maximum Duration period for Model DV3200 and DV3400 is 5 ms; 10ms for Model DV3100. The Trigger condition will not be considered as "True" until the entered value for the selected signal has been valid for the indicated duration period.

**Identifier** - Change the identifier to something meaningful for the match condition if you do not want the default "Match #" to be displayed in the formula and the graphical configuration area of the trigger screen.

#### 2.3.2.1.1.6 Greater Than Match

The Greater Than Match type is only available on DigiView DV3 series.

The Greater Than Match Editor:

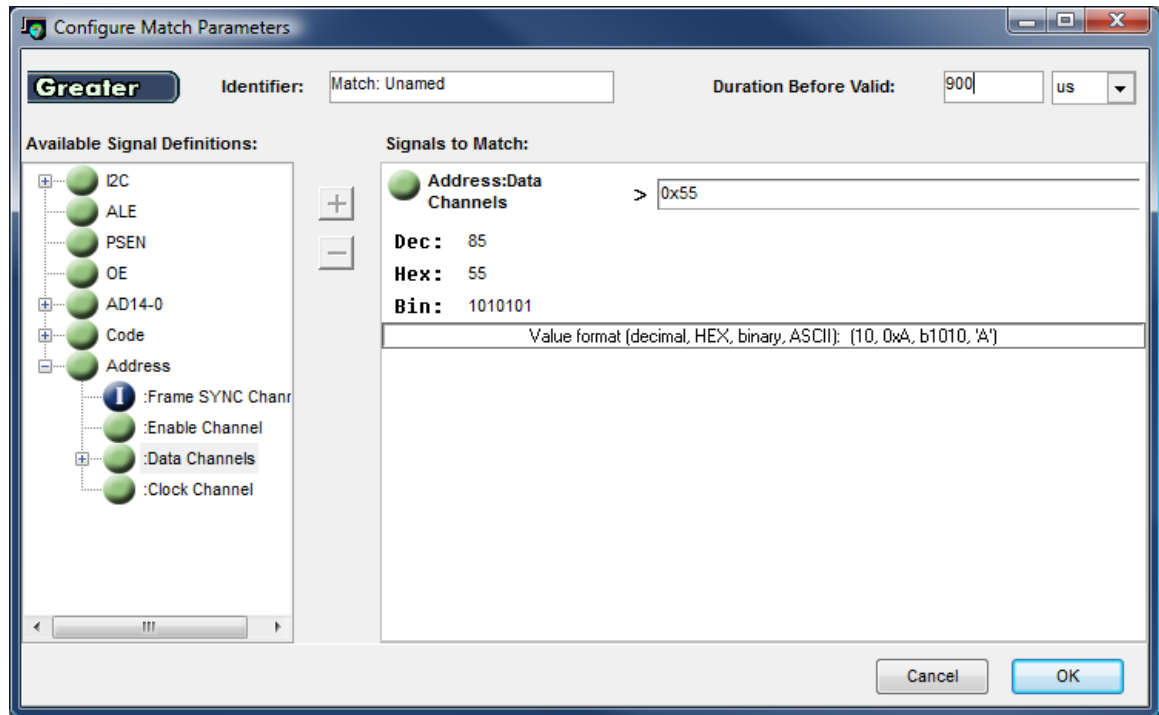

**ADD a Signal** - Highlight a defined signal from the left portion of the window and click the "+" button to add it as the Greater Than Match. You can also just "Double-Click" the defined signal to automatically add it. NOTE: High Level signal definitions (such as State, I2C, or etc) cannot be added directly as a complete signal. However, the individual portions of the signal (such as the Data Channel portion of a State Signal) can be added in the same manner. To see the sub-portions of a signal, click the "expand" button in the left column next to the signal's name, then add the sub portion in the same manner as any other signal.

For instance, if you have defined a Synchronous Serial signal (i.e. SPI) and you want to add the :Enable portion of the signal to the Greater Than match, then expand it and double-click on :Enable. It would then appear on the right portion of the editor.

The Greater Than Match type only accepts one signal at a time. After a signal has been added, the "+" (ADD) button will be disabled (as shown above) until the current signal is removed.

**Note:** If a signal is valid for the trigger configuration, a green icon will be displayed next to it. Any other icon, such as the blue circle above on the Frame Sync channel of the Address signal, indicates a channel state that is invalid for triggering. This particular icon indicates that the channel has been configured as 'Ignored' in the signal definition editor.

**Delete a Signal** - Highlight a signal in the right portion of the window (or mouse-over its bit selections) and click the "-" button to delete it from the Greater Than Match.

**Match Value Format** - The value for the Greater Than Match type can be entered in Decimal, HEX, Binary or ASCII format. The value will be limited to the maximum value allowed for the selected signal, which will depend on the number of bit positions assigned to the signal. The formats for entering each value type is described below.

**Decimal:** Enter any valid decimal value. An Invalid value will be cleared to 0 or assumed to be

HEX.

**HEX:** Start the value with an "x" or a "0x". If too many digits are entered, the most significant nibble (leftmost) will be discarded. Any non-HEX digit will be ignored.

**Binary:** Enter "b" followed by "1's" and "0's". If too many digits are typed, the MSb (leftmost bit) will be discarded. Any numerical value larger than a "1" or non-numerical character will be considered a "1".

**ASCII:** Start the value with a single or double quote.

**Duration** - Enter the match duration by selecting the units then typing the value. The Maximum Duration period for Model DV3200 and DV3400 is 5 ms; 10ms for Model DV3100. The Trigger condition will not be considered as "True" until the entered value for the selected signal has been valid for the indicated duration period.

**Identifier** - Change the identifier to something meaningful for the match condition if you do not want the default "Match #" to be displayed in the formula and the graphical configuration area of the trigger screen.

## 2.3.2.1.1.7 Greater Than or Equal Match

The Greater Than or Equal Match type is only available on DigiView DV3 series.

The Greater Than or Equal Match Editor:

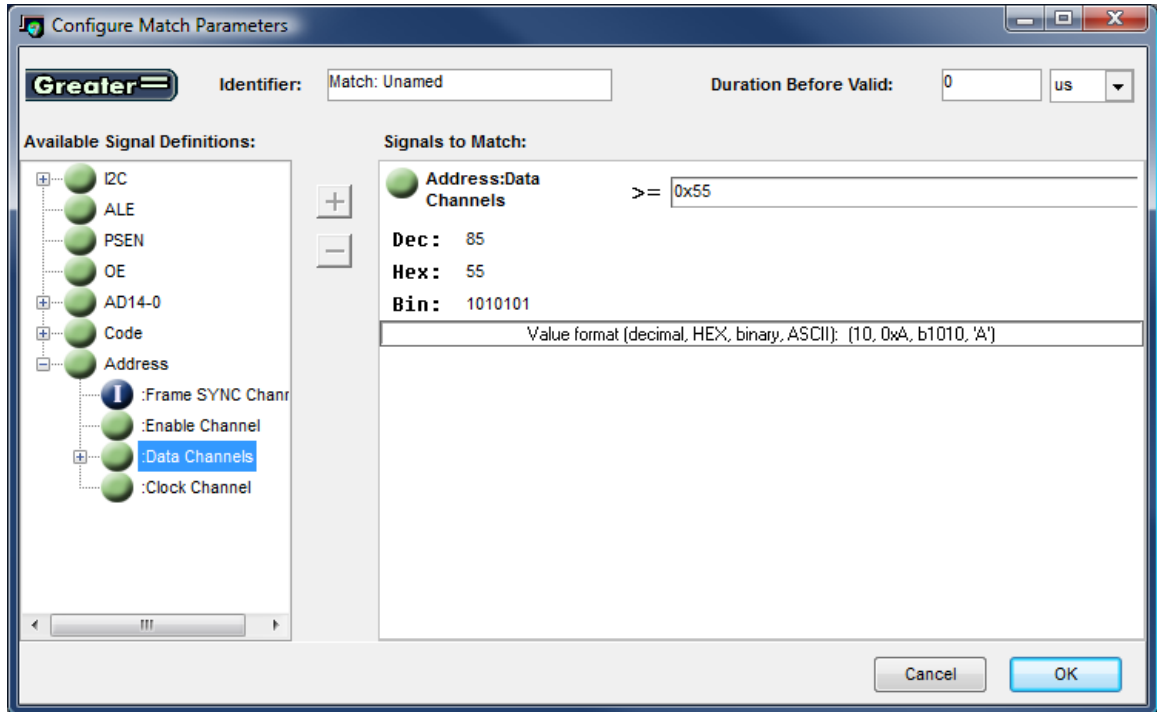

**ADD a Signal** - Highlight a defined signal from the left portion of the window and click the "+" button to add it as the Greater Than or Equal Match. You can also just "Double-Click" the defined signal to automatically add it. **NOTE:** High Level signal definitions (such as State, I2C, or etc) cannot be added directly as a complete signal. However, the individual portions of the signal (such as the Data Channels portion of a State Signal) can be added in the same manner. To see the sub-portions of a signal, click the "expand" button in the left column next to the signal's name, then add the sub portion in the same manner as any other signal.

For instance, if you have defined a Synchronous Serial signal (i.e. SPI) and you want to add the :Enable portion of the signal to the Greater Than match, then expand it and double-click on :Enable. It would then appear on the right portion of the editor.

The Greater Than or Equal Match type only accepts one signal at a time. After a signal has been added, the "+" (ADD) button will be disabled (as shown above) until the current signal is removed.

**Note:** If a signal is valid for the trigger configuration, a green icon will be displayed next to it. Any other icon, such as the blue circle above on the Frame Sync channel of the Address signal, indicates a channel state that is invalid for triggering. This particular icon indicates that the channel has been configured as 'Ignored' in the signal definition editor.

**Delete a Signal** - Highlight a signal in the right portion of the window (or mouse-over its bit

selections) and click the "-" button to delete it from the Greater Than or Equal Match.

**Match Value Format** - The value for the Greater Than or Equal Match type can be entered in Decimal, HEX, Binary or ASCII format. The value will be limited to the maximum value allowed for the selected signal, which will depend on the number of bit positions assigned to the signal. The formats for entering each value type is described below.

**Decimal:** Enter any valid decimal value. An Invalid value will be cleared to 0 or assumed to be HEX.

**HEX:** Start the value with an "x" or a "0x". If too many digits are entered, the most significant nibble (leftmost) will be discarded. Any non-HEX digit will be ignored.

**Binary:** Enter "b" followed by "1's" and "0's". If too many digits are typed, the MSb (leftmost bit) will be discarded. Any numerical value larger than a "1" or non-numerical character will be considered a "1".

**ASCII:** Start the value with a single or double quote.

**Duration** - Enter the match duration by selecting the units then typing the value. The Maximum Duration period for Model DV3200 and DV3400 is 5 ms; 10ms for Model DV3100. The Trigger condition will not be considered as "True" until the entered value for the selected signal has been valid for the indicated duration period.

**Identifier** - Change the identifier to something meaningful for the match condition if you do not want the default "Match #" to be displayed in the formula and the graphical configuration area of the trigger screen.

#### 2.3.2.1.1.8 Less Than Match

The Less Than Match type is only available on DigiView DV3 series.

The Less Than Match Editor:

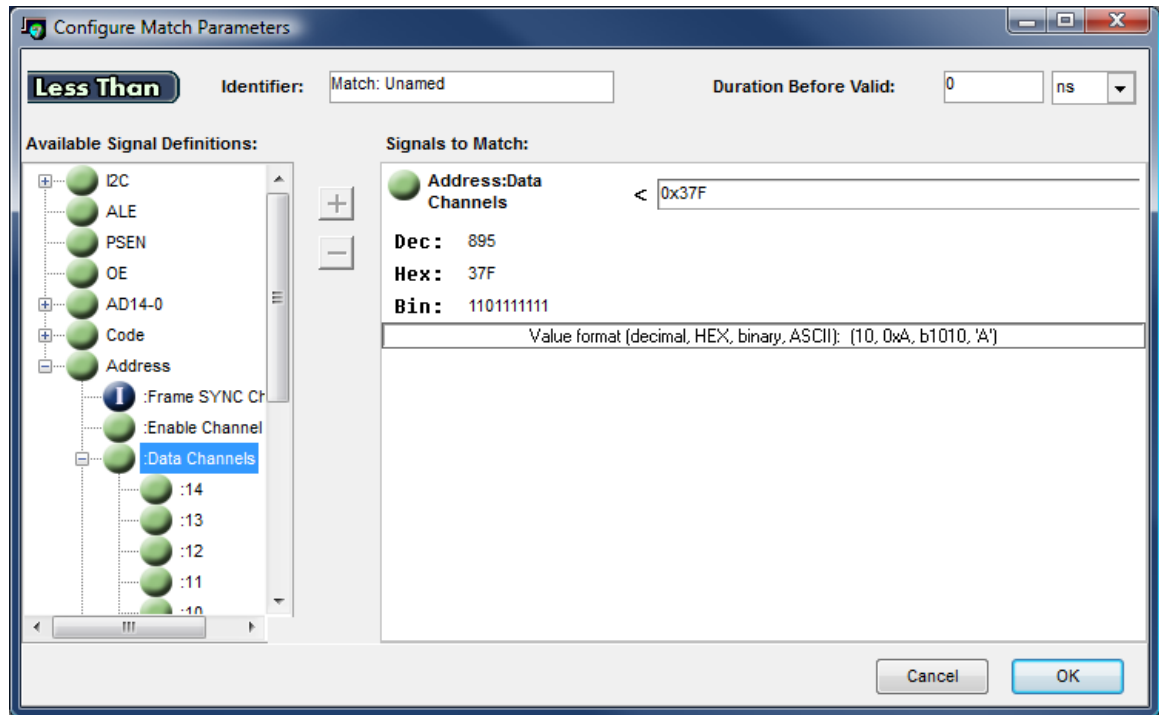

**ADD a Signal** - Highlight a defined signal from the left portion of the window and click the "+" button to add it as the Less Than Match. You can also just "Double-Click" the defined signal to automatically add it. NOTE: High Level signal definitions (such as State, I2C, or etc) cannot be added directly as a complete signal. However, the individual portions of the signal (such as the Data Channels portion of a State Signal) can be added in the same manner. To see the sub-portions of a signal, click the "expand" button in the left column next to the signal's name, then add the sub portion in the same manner as any other signal.

For instance, if you have defined a Synchronous Serial signal (i.e. SPI) and you want to add the :Enable portion of the signal to the Less Than match, then expand it and double-click on :Enable. It would then appear on the right portion of the editor.

The Less Than Match type only accepts one signal at a time. After a signal has been added, the "+" (ADD) button will be disabled (as shown above) until the current signal is removed.

**Note:** If a signal is valid for the trigger configuration, a green icon will be displayed next to it. Any other icon, such as the blue circle above on the Frame Sync channel of the Address signal, indicates a channel state that is invalid for triggering. This particular icon indicates that the channel has been configured as 'Ignored' in the signal definition editor.

**Delete a Signal** - Highlight a signal in the right portion of the window (or mouse-over its bit selections) and click the "-" button to delete it from the Less Than Match.

**Match Value Format** - The value for the Less Than Match type can be entered in Decimal, HEX, Binary or ASCII format. The value will be limited to the maximum value allowed for the selected signal, which will depend on the number of bit positions assigned to the signal. The formats for entering each value type is described below.

**Decimal:** Enter any valid decimal value. An Invalid value will be cleared to 0 or assumed to be



HEX.

**HEX:** Start the value with an "x" or a "0x". If too many digits are entered, the most significant nibble (leftmost) will be discarded. Any non-HEX digit will be ignored.

**Binary:** Enter "b" followed by "1's" and "0's". If too many digits are typed, the Msb (leftmost bit) will be discarded. Any numerical value larger than a "1" or non-numerical character will be considered a "1".

**ASCII:** Start the value with a single or double quote.

**Duration** - Enter the match duration by selecting the units then typing the value. The Maximum Duration period for Model DV3200 and DV3400 is 5 ms; 10ms for Model DV3100. The Trigger condition will not be considered as "True" until the entered value for the selected signal has been valid for the indicated duration period.

**Identifier** - Change the identifier to something meaningful for the match condition if you do not want the default "Match #" to be displayed in the formula and the graphical configuration area of the trigger screen.

## 2.3.2.1.1.9 Less Than or Equal Match

The Less Than or Equal Match type is only available on DigiView DV3 series.

The Less Than or Equal Match Editor:

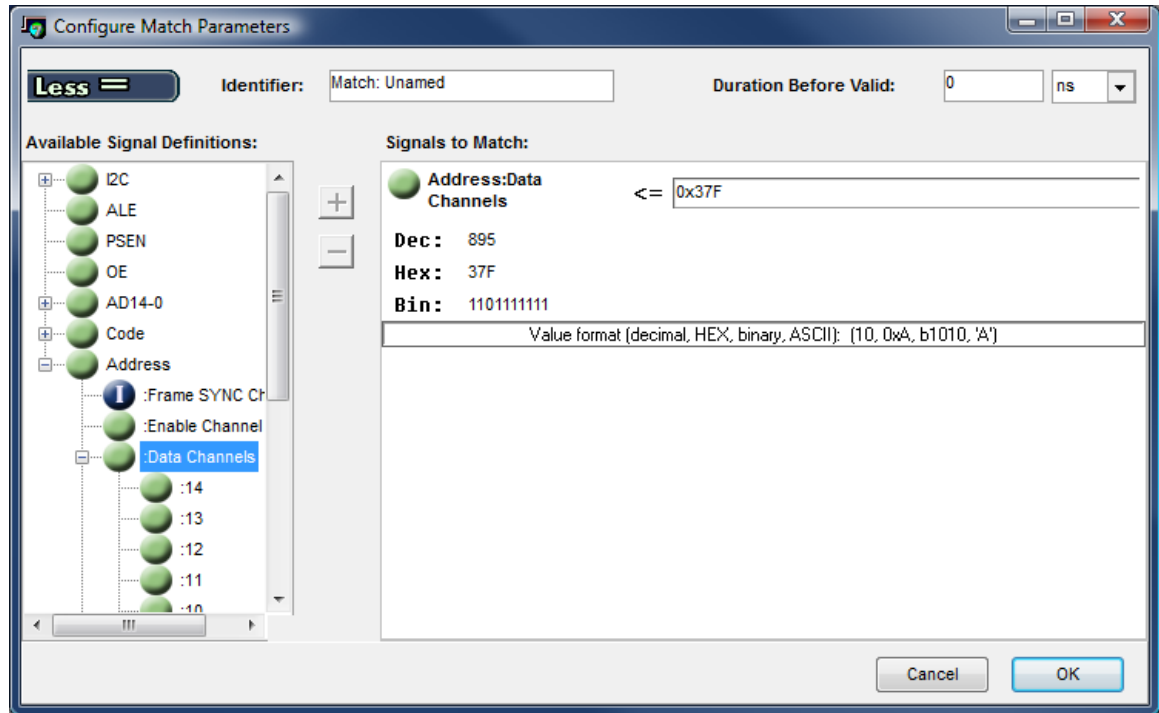

**ADD a Signal** - Highlight a defined signal from the left portion of the window and click the "+" button to add it as the Less Than or Equal Match. You can also just "Double-Click" the defined signal to automatically add it. NOTE: High Level signal definitions (such as State, I2C, or etc) cannot be added directly as a complete signal. However, the individual portions of the signal (such as the DATA portion of a State Signal) can be added in the same manner. To see the sub-portions of a signal, click the "expand" button in the left column next to the signal's name, then add the sub portion in the same manner as any other signal.

For instance, if you have defined a Synchronous Serial signal (i.e. SPI) and you want to add the :Enable portion of the signal to the Greater Than match, then expand it and double-click on :Enable. It would then appear on the right portion of the editor.

The Less Than or Equal Match type only accepts one signal at a time. After a signal has been added, the "+" (ADD) button will be disabled (as shown above) until the current signal is removed.

**Note:** If a signal is valid for the trigger configuration, a green icon will be displayed next to it. Any other icon, such as the blue circle above on the Frame Sync channel of the Address signal, indicates a channel state that is invalid for triggering. This particular icon indicates that the channel has been configured as 'Ignored' in the signal definition editor.

**Delete a Signal** - Highlight a signal in the right portion of the window (or mouse-over its bit selections) and click the "-" button to delete it from the Less Than or Equal Match.

**Match Value Format** - The value for the Less Than or Equal Match type can be entered in Decimal, HEX, Binary or ASCII format. The value will be limited to the maximum value allowed for the selected signal, which will depend on the number of bit positions assigned to the signal. The formats for entering each value type is described below.

**Decimal:** Enter any valid decimal value. An Invalid value will be cleared to 0 or assumed to be HEX.

**HEX:** Start the value with an "x" or a "0x". If too many digits are entered, the most significant nibble (leftmost) will be discarded. Any non-HEX digit will be ignored.

**Binary:** Enter "b" followed by "1's" and "0's". If too many digits are typed, the MSb (leftmost bit) will be discarded. Any numerical value larger than a "1" or non-numerical character will be considered a "1".

**ASCII:** Start the value with a single or double quote.

**Duration** - Enter the match duration by selecting the units then typing the value. The Maximum Duration period for Model DV3200 and DV3400 is 5 ms; 10ms for Model DV3100. The Trigger condition will not be considered as "True" until the entered value for the selected signal has been valid for the indicated duration period.

**Identifier** - Change the identifier to something meaningful for the match condition if you do not want the default "Match #" to be displayed in the formula and the graphical configuration area of the trigger screen.

## 2.3.2.1.2 Sequencer

The trigger circuit of the DV3 series includes 4 cascadable, 4 stage sequencers. These can be chained in any combination to produce longer sequences ( 1 @ 16 stages, 2 @ 8 stages...). Stage inputs are OR gates so that more than 1 term of match conditions can be connected to each stage. Each stage includes a 20 bit pass counter.

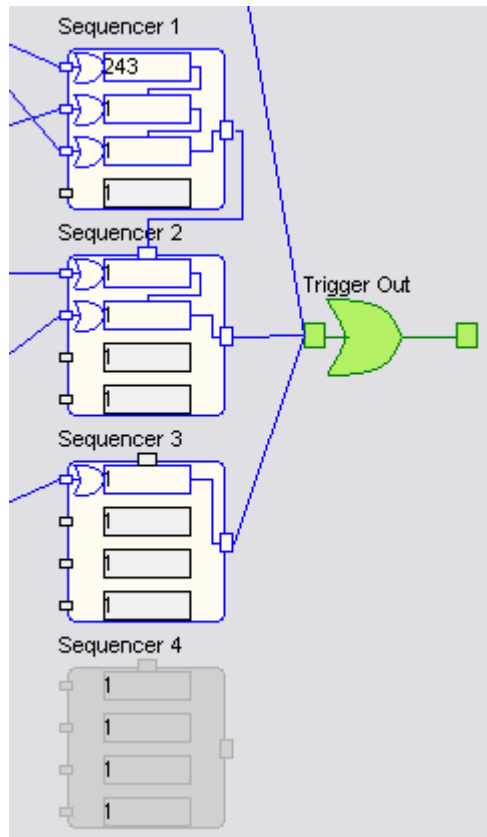

### Setting the Counter

Double-Click in the counter to edit its value. When finished editing, either use the "Enter" or "Tab" key to assign the new value to the configuration. Anytime the configuration changes, use the "APPLY" button to activate the new settings.

NOTE: "0" is an invalid value, so the counter editor will enforce a minimum count of "1".

### 2.3.2.1.3 Trigger Selection Editor

From this window, trigger configurations can be created, deleted, renamed and copied.

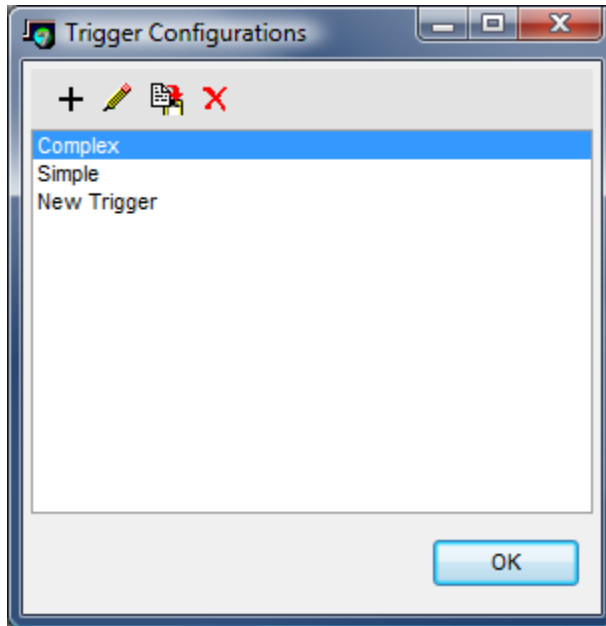

#### **New Configuration**

- Select the "+" button to create and add a new configuration.



#### **Rename Configuration**

- Select the "pencil" button to edit the name of the configuration.



#### **Copy Configuration**

- Highlight an existing configuration and select the "copy" button to create a new configuration with identical properties. This is useful if you need a slightly modified version of a complex configuration. Using the copy button will help you avoid re-configuring from scratch.



#### **Delete Configuration**

- Use the "delete" button to dispose of a configuration. NOTE: all deletions are final.

## 2.4 Analyzer Options

Each model of DigiView has a different set of options that can be adjusted directly from the software. These options are shown summarized below.

## Model DV3100 Hardware Options

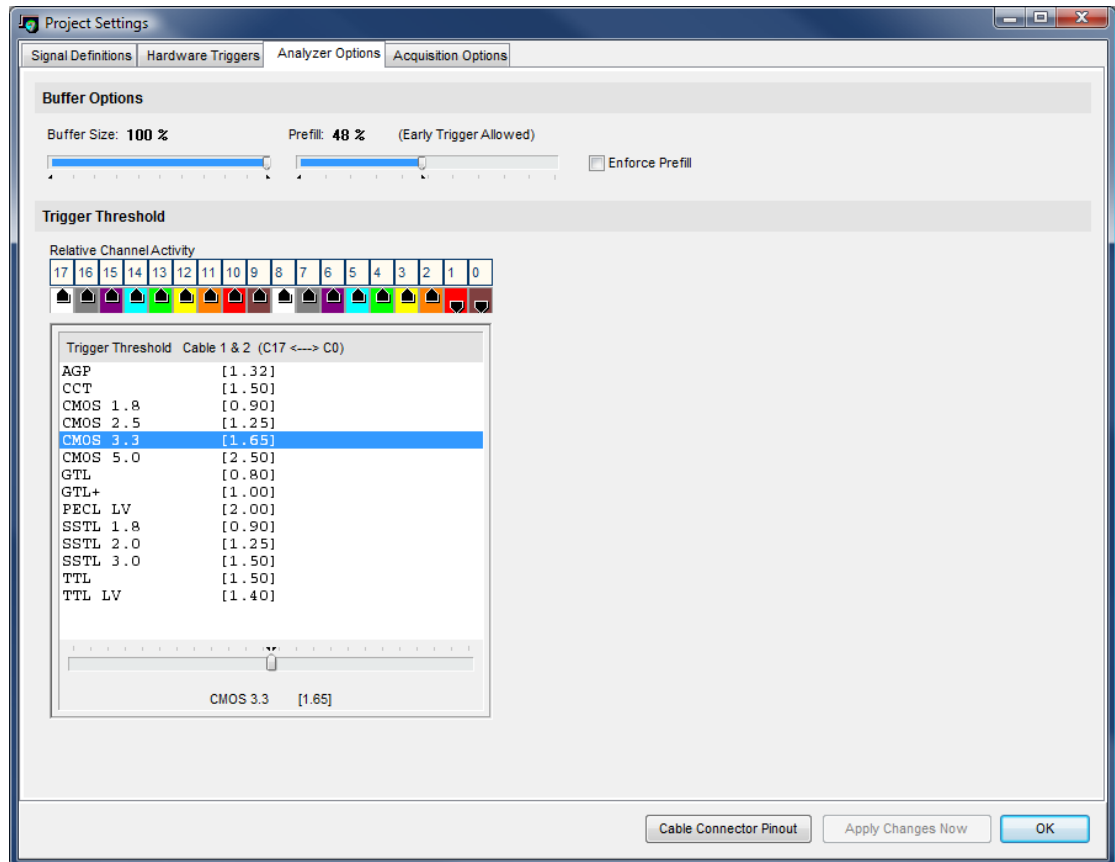

**Buffer Size** - Adjust the amount of capture buffer (1% - 100%) to use in the Hardware.

**Prefill** - Adjust the amount of buffer to use for data captured before the trigger event. If no trigger event occurs, the analyzer will continuously refresh this portion of the buffer with the most recent data. When the trigger event occurs, the remaining portion of the buffer will be filled with post-trigger data. The behavior of the prefill (or pre-trigger) portion of the buffer can be modified by the Enforce Prefill option.

**Enforce Prefill** - Select this option to force the analyzer to fill the buffer to the Prefill setting before looking for a trigger condition. If you do not need the full prefill amount before the trigger condition occurs, then uncheck this option to allow early detection of the trigger.

**Channel Monitor** - This area displays the channel / color relationship and each channels relative activity.

**Trigger Threshold** - Select the trigger threshold for the group of 18 Channels (9 channels per cable). The selection can be made by highlighting one of the pre-defined values or use the slider beneath these values to select a custom value. The valid range for the threshold on model DV3100 is 0.5V to 2.8V.

### Model DV3200 Hardware Options

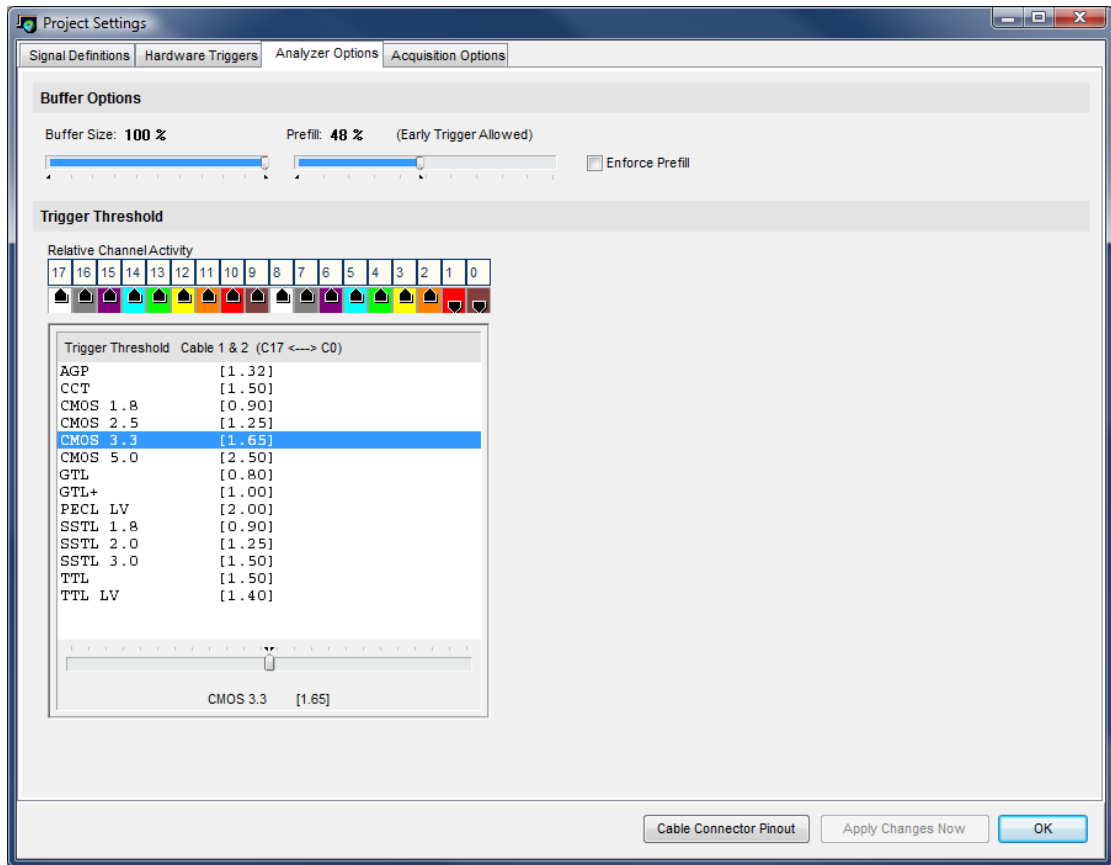

**Buffer Size** - Adjust the amount of capture buffer (1% - 100%) to use in the Hardware.

**Prefill** - Adjust the amount of buffer to use for data captured before the trigger event. If no trigger event occurs, the analyzer will continuously refresh this portion of the buffer with the most recent data. When the trigger event occurs, the remaining portion of the buffer will be filled with post-trigger data. The behavior of the prefill (or pre-trigger) portion of the buffer can be modified by the Enforce Prefill option.

**Enforce Prefill** - Select this option to force the analyzer to fill the buffer to the Prefill setting before looking for a trigger condition. If you do not need the full prefill amount before the trigger condition occurs, then uncheck this option to allow early detection of the trigger.

**Channel Monitor** - This area displays the channel / color relationship and each channels relative activity.

**Trigger Threshold** - Select the trigger threshold for the group of 18 Channels (9 channels per cable). The selection can be made by highlighting one of the pre-defined values or use the slider beneath these values to select a custom value. The valid range for the threshold on model DV3200 is 0.5V to 2.8V.

### Model DV3400 Hardware Options

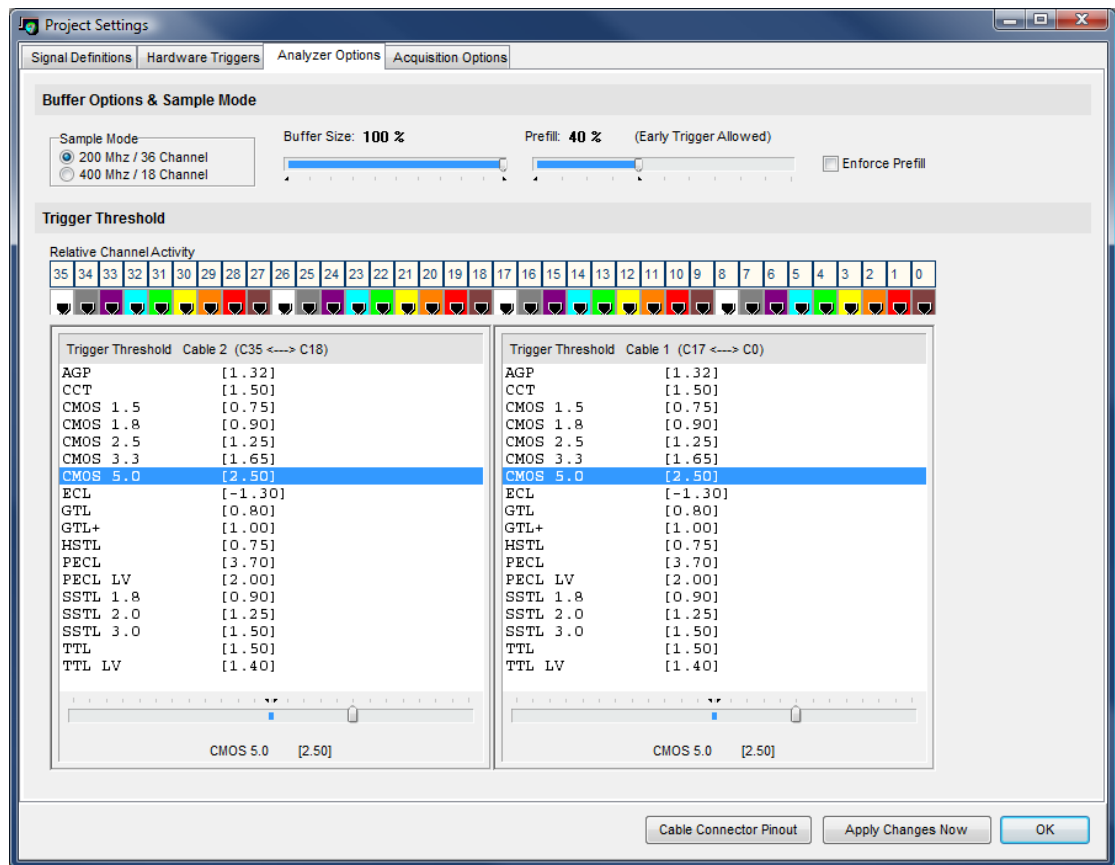

**Sample Mode** - Select the sample rate and channel mode.

**Buffer Size** - Adjust the amount of capture buffer (1% - 100%) to use in the Hardware.

**Prefill** - Adjust the amount of buffer to use for data captured before the trigger event. If no trigger event occurs, the analyzer will continuously refresh this portion of the buffer with the most recent data. When the trigger event occurs, the remaining portion of the buffer will be filled with post-trigger data. The behavior of the prefill (or pre-trigger) portion of the buffer can be modified by the Enforce Prefill option.

**Enforce Prefill** - Select this option to force the analyzer to fill the buffer to the Prefill setting before looking for a trigger condition. If you do not need the full prefill amount before the trigger condition occurs, then uncheck this option to allow early detection of the trigger.

**Channel Monitor** - This area displays the channel / color relationship and each channels relative activity.

**Trigger Thresholds** - Select the trigger threshold for each group of 18 Channels (18 channel models will only display 1 threshold setting). The selection can be made by highlighting one of the pre-defined values or use the slider beneath these values to select a custom value. The valid range for each threshold on model DV3400 is -6V to +6V.



## 2.5 Acquisition Options

### Display Behavior

These options control the default behavior when data is transferred for display on the screen. This includes newly captured data and data loaded from browsing through the Capture History.

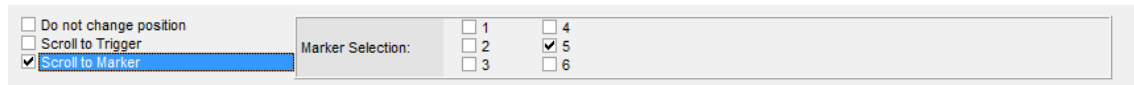

<input type="checkbox"/> Do not change position	Marker Selection:	<input type="checkbox"/> 1	<input type="checkbox"/> 4
<input type="checkbox"/> Scroll to Trigger		<input type="checkbox"/> 2	<input checked="" type="checkbox"/> 5
<input checked="" type="checkbox"/> Scroll to Marker		<input type="checkbox"/> 3	<input type="checkbox"/> 6

**Do Not Change Position** - When selected, the current time reference point remains the same. The Waveform Views will remain at their current time reference instead of scrolling to the trigger point or a selected marker position. NOTE: List windows always adjust to the time of the closest matching line of data, so they may change position slightly, based on the new data loaded.

**Scroll to Trigger** - When selected, the waveform windows will scroll to the trigger point.

**Scroll to Marker** - When selected, the waveform views will scroll to the chosen marker. After this option is selected, the Marker Selection options are available to make the marker selection.

### Capture History Options

These options control when to save captures to the history, the amount of storage to use and determine what action to take if these settings are exceeded. Changes to most of the options below require pressing the "Apply" button in order to reconfigure the history buffer. If this is required, the buttons will highlight with a red border to notify you. Pressing the "Cancel" button or leaving the Acquisition option window (when the buttons are highlighted) will discard any changes and restore your previous settings. When the apply button is pressed, the history will be reconfigured to the new settings and the database rebuilt. If needed, some files will be deleted to meet the new settings, starting with the oldest captures first.

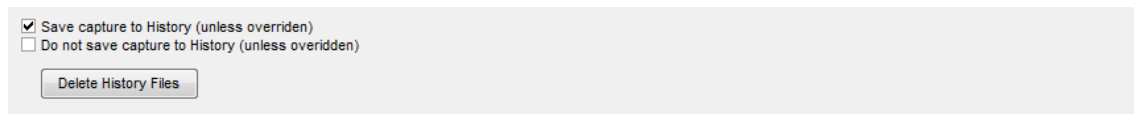

<input checked="" type="checkbox"/> Save capture to History (unless overridden)
<input type="checkbox"/> Do not save capture to History (unless overridden)
<input type="button" value="Delete History Files"/>

**Save capture History** - When selected, each capture is stored in the history unless overridden by a plug-in or Auto Search window.

**Do Not Save capture History** - When selected, each capture is discarded when a new capture is acquired unless overridden by a plug-in or Auto Search window.

**Delete History Files** - When pressed, all capture history files for the current project will be deleted, including the one being viewed. When opening a project file that does not have any history, the data stored within the project file will be saved as a history file. If history files exist for the project, but the current data is not found in the history, the data will be added to the history at the proper chronological position.

The screenshot shows a configuration dialog box with the following elements:

- Four checkboxes on the left:  Limit by Number of Captures (highlighted in blue),  Limit by Size on Disk,  Limit by Disk Free Space, and  Overwrite when limitation reached. The  Halt when limitation reached checkbox is not checked.
- Two buttons at the bottom left: "Apply" and "Cancel", both enclosed in a red rectangular box.
- Three rows of configuration fields on the right:
  - Row 1: "Maximum Number of Captures to keep:" with a text box containing "702771" and "Current Count: 702771".
  - Row 2: "Maximum Disk Size for Capture History:" with a text box containing "60", a dropdown menu set to "Gigabytes", and "Current Size: 53.57 GB".
  - Row 3: "Minimum Disk Size to preserve:" with a text box containing "100", a dropdown menu set to "Megabytes", and "Free Space: 25.63 GB".

**Limit by Number of Captures** - Select this option to specify the exact number of captures to keep. Once selected, the number of captures can be specified in the *Maximum Number of Captures to keep* edit box.

**Limit by Size on Disk** - Select this option to specify the size of the storage space to use for the capture history. Once selected, the size can be selected in the *Maximum Disk Size for Capture History* editor on the right.

**Limit by Disk Free Space** - Select this option to specify the amount of free space to reserve on the Hard Drive. Once selected, the size can be selected in the *Minimum Disk Size to preserve* editor on the right.

**Halt when limitation reached** - Select this option to halt the analyzer if any of the limitations specified above have been exceeded. A warning dialog will be displayed with information on which limit was exceeded.

**Overwrite when limitation reached** - Select this option to automatically delete the oldest capture(s) to make room for the newest capture when any of the limitations specified above have been exceeded. The history will be maintained as a First in, First out (FIFO) buffer using the parameters specified above. When limitations are reached, no warning is presented as this configuration will automatically maintain the buffer using the specified limitations as new captures are added.

**History Monitor** - For your convenience, the current Capture Count, Storage Size and Disk Free Space are displayed to the right of the editors. This display is updated as capture files are added or deleted and can be used as a History monitor while capturing.

## 2.6 Color Themes

Several pre-defined color schemes and a custom scheme can be selected from the Color Theme Selection window. This window is accessed from the CONFIG menu.

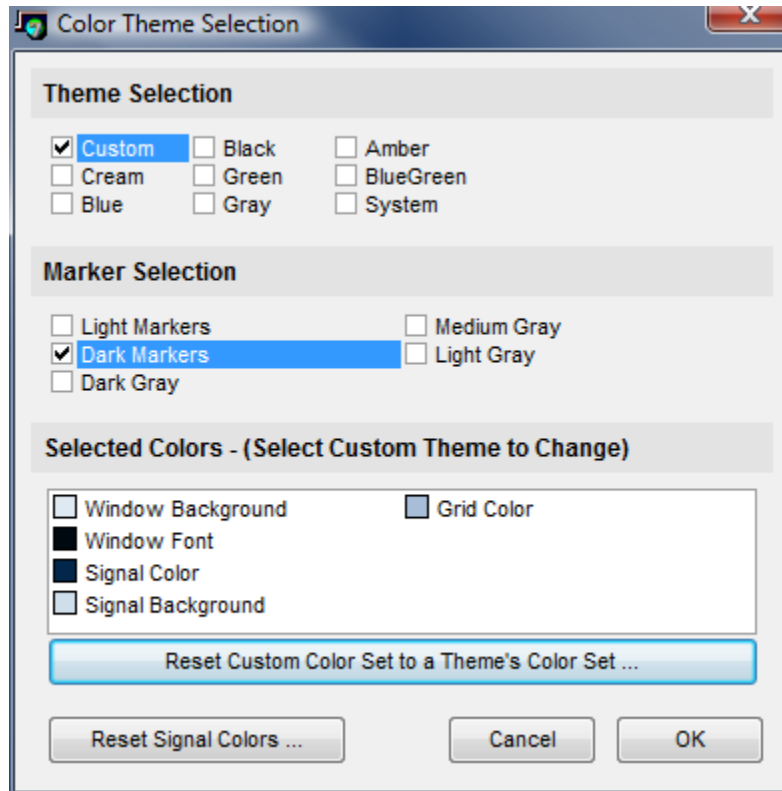

**Theme Selection** - Select "custom" if you would like to define your own colors, otherwise select from one of the pre-defined color schemes. The Marker selection will be chosen automatically and disabled for some theme choices.

**Marker Selection** - When selecting a theme, a compatible marker set will be automatically selected. However, you can choose any of the marker "color sets" for the best marker visibility.

**Selected Colors** - These items display the current color values of the selected theme. To edit these values, choose "custom" in the Theme Selection area, then click on the item in this section that you would like to change.

**Reset Signal Colors** - Click this button to reset any Signal colors that do not match the current color theme. Normally, changing the theme will also change a signal's colors. However, if you have customized a signal's color, then it will not change with theme changes. To reset signal colors, click this button and select an option from the menu that appears. To reset a specific signal's colors without changing other signals, use that signal's editor instead.

**Reset Custom to Theme** - This will reset or change the colors of the custom theme to match any of the pre-defined themes. To make the change, select the "Custom" theme, then click the button and select one of the themes from the menu that appears.

## Theme Examples:

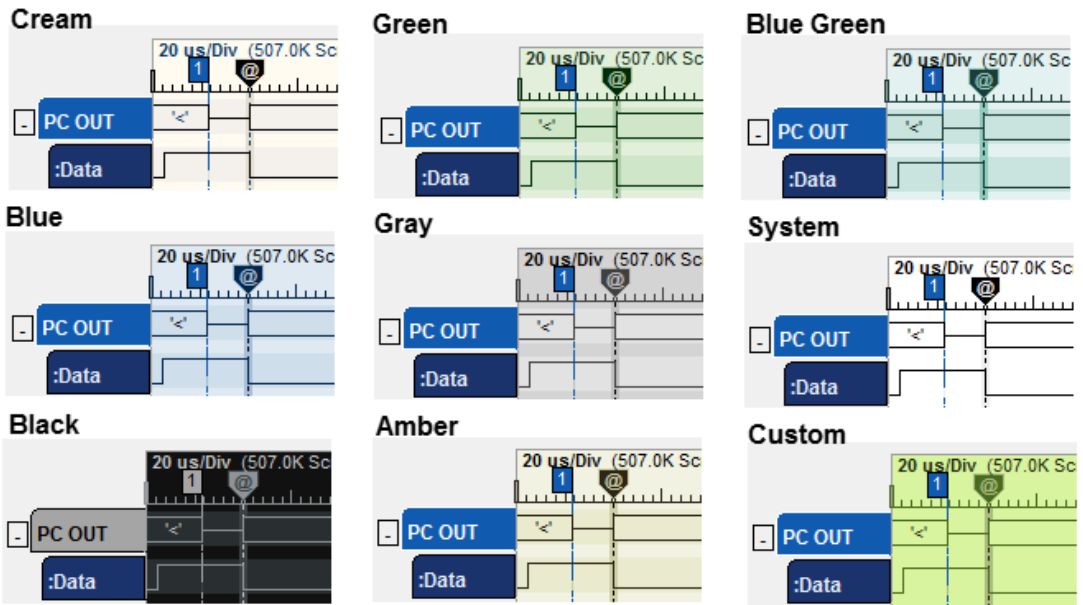

## 2.7 Environment Settings

Several Environment options are available and can be accessed from the CONFIG menu.

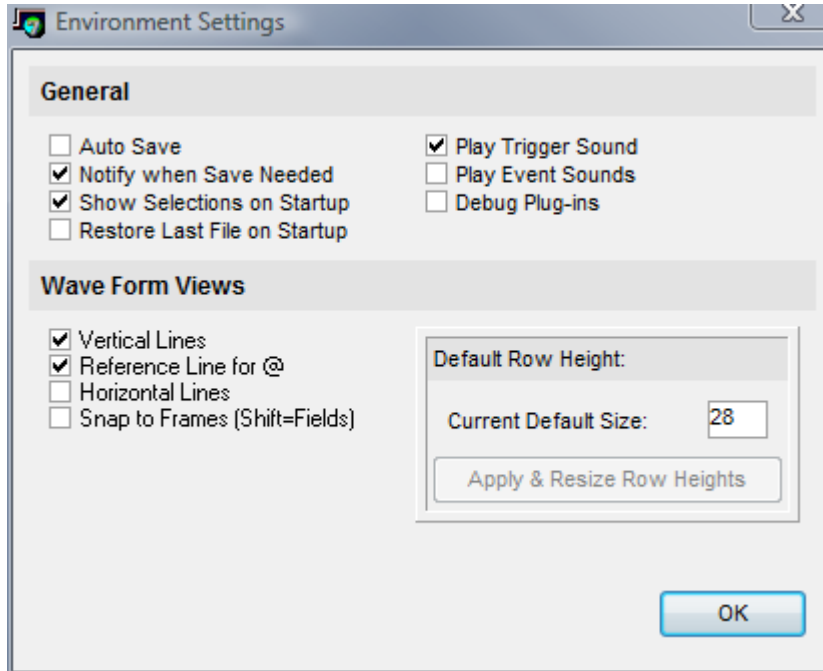

### General

**Auto Save** - Select this option to automatically save the current file. All current settings and data will be saved to the file when exiting the program or opening another file. The "Notify when Save Needed" option is disabled when this option is enabled. (see: [Saving and Restoring](#)<sup>[129]</sup>)

**Notify when Save Needed** - Select this option if you want to be notified of unsaved changes before exiting the program or opening another file. The "Auto save" option is disabled when this option is enabled. (see: [Saving and Restoring](#)<sup>[129]</sup>)

**Show Selections on Startup** - Selected by default, this option presents a Choice of items to load when the software is launched. De-select this option to skip the selection window on startup. If disabled, the "Restore Last File on Startup" option will be enabled.

Startup Selections:

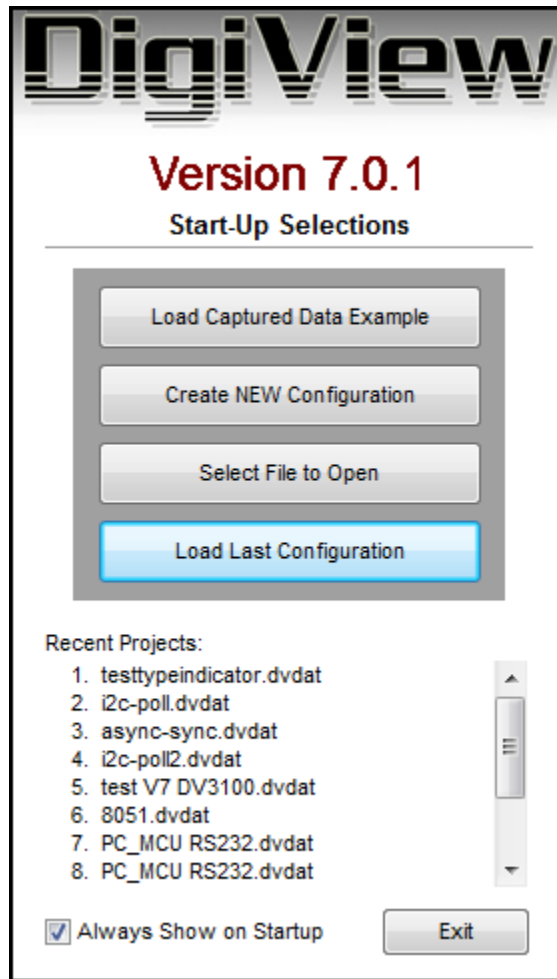

**Restore Last File on Startup** - Select this option to skip startup options and automatically load the last file used previously. If disabled, the "Show Selections on Startup" option will be enabled (see: [Saving and Restoring](#)<sup>[129]</sup>). If the last file used is missing then the Startup Up selections window will open.

**Play Trigger Sound** - Selected by default, this option causes the software to present an audible indication of Trigger events. In continuous run mode, the alert will sound only once on repeated trigger conditions. De-select this option if you do not want the audible alert. The Audible sound can be customized by using the Operating systems "Sounds" control applet.

**Play Event Sounds** - Selected by default, this option causes the software to present an audible indication of any Snap or Scroll events. De-select this option if you do not want the audible alert. The Audible sound can be customized by using the Operating systems "Sounds" control applet.

**Debug Plugins** - Select this option to have the DigiView software pause when loading a custom plugin. A message dialog will open and DigiView execution will wait until you close the dialog. This provides a means for the developer to attach the DigiView process to an external debugger before the plugin module begins to execute.

## Wave Form Views

**Vertical Lines** - Check this option to display vertical lines at the time divisions in the Wave Form views.

**Reference Line for @** - Check this item to display a vertical line at the time reference marker (@) of the Wave Form views.

**Horizontal Lines** - Check this option to display a horizontal line beneath each visible signal in the Wave Form views. This may be desired to help determine the state of multiple Boolean signals when zoomed in at maximum resolution.

**Snap to Frames** - Check this option to snap to frames by default and use the shift key to snap to fields. If unchecked, the default is to snap to fields and use the shift key to snap to frames. This option affects all marker and signal snapping features of the waveform view.

**Reset Row Height** - Click the "Apply" button to reset the heights of all signals in the Wave Form displays to the value entered as the Current Default size. Edit the current value to enable the "Apply" button.

# Capturing Data

**Part**





### 3 Capturing Data

Once [signals](#)<sup>[7]</sup> and [triggers](#)<sup>[27]</sup> are defined, you can capture a new buffer of data at any time by pressing the 'Run' or 'Auto Run' buttons. If you tire of waiting on a trigger or it triggers but you tire of waiting for it to fill up the buffer, you can STOP the capture to transfer the capture buffer to the screen. When transferred to the screen, the capture is also stored in the capture history for later analysis (based on [Acquisition settings](#)<sup>[53]</sup>).



**Preview** - This mode will automatically transfer data to the PC repeatedly even if a trigger condition has not been defined. This mode is very useful to Monitor signals while making connections and only utilizes a small portion of the hardware buffer. In this mode, the buffer size and duration of data collection is adjusted automatically to provide a "peek" of the logic activity and is not intended for normal data analysis. The result is a virtual "LIVE" mode that does not try to search the data (Auto Search windows) or store the data in the capture history. The data displayed will be discarded when the results of a normal Run (single shot) or Auto Run are displayed.



**Auto Run** - This will "ARM" the hardware, wait for the trigger condition, automatically transfer the data to the PC when the buffer is full and automatically re-arm to repeat the process until the Stop or Halt button is pressed. If you are waiting on a Trigger condition that you expected to occur, you can select the "Stop" button to view the data already collected in the pre-fill portion of the hardware buffer (see [Analyzer Options](#)<sup>[49]</sup>).



**Run** - This will "ARM" the hardware and automatically transfer the data to the PC when the buffer is full. If you do not want to wait for a long capture, you can select the "STOP" button to force a transfer of the current data captured. If you are waiting on a Trigger condition that you expected to occur, you can select the "Stop" button to view the data already collected in the pre-fill portion of the hardware buffer (see [Analyzer Options](#)<sup>[49]</sup>).



**Stop** - This will halt the capture and transfer whatever was captured to the PC for your analysis.



**Halt** - This will reset the hardware and abort the capture without changing the data currently being analyzed. When the halt button is pressed, no data is transferred to the screen or the Capture History.

When you click on 'Run' (or Auto Run), you are actually arming the trigger circuit. Upon trigger, the hardware allows the buffer to continue past the pre-fill point and to continue filling up (post-fill). Once the buffer is full, it is transferred to the PC. After the buffer is transferred, the hardware immediately resets and begins pre-filling in preparation for the next RUN. In Auto Run mode, the next Run starts automatically.

[Hardware Status](#)<sup>[63]</sup>

[Capture History](#)<sup>[64]</sup>

[Capture Troubleshooting](#)<sup>[68]</sup>

Note that the DigiView hardware is always capturing and storing data in a circular queue. While you are looking at the last capture, the hardware is pre-filling the buffer to the pre-fill size selected. When the buffer reaches the pre-fill setting, the hardware continues capturing and storing data in a circular queue fashion so that the most recent data is always available while waiting on the trigger condition.

(see also: [Acquisition Options](#)<sup>53</sup>, [Analyzer Options](#)<sup>49</sup>, [DigiView Compression](#)<sup>132</sup>)

## 3.1 Hardware Status

The lower right corner and the upper right corner of the main window display Hardware Status information. This information will keep you informed of the hardware's buffer usage and capture state.

### Buffer Usage



The hardware buffer's usage is displayed as a bar graph and numerical percentage indicating the used portion of the buffer. As data is stored in the buffer, the bar and the percentage will increase. When the buffer reaches 100%, the data will be transferred to the PC for analysis.

The buffer may take mere milliseconds to fill or up to months to fill depending on the signals defined (see: [Signals](#)<sup>[71]</sup>) and the amount of activity on those signals. If you have configured the buffer's prefill option to 'forced' (no early trigger), the buffer indicators may appear to stall. This is correct behavior when very little or no signal activity is present or when the analyzer is waiting for the trigger condition.

During a "waiting for Trigger" period, the analyzer continues to capture and store the newest data in the prefill portion of the buffer, while discarding the oldest data. Once the trigger event occurs, the buffer will stop discarding the oldest data, keep the newest data (the prefill portion) and continue to capture until the buffer is full (see: Enforce Prefill in [Analyzer Options](#)<sup>[49]</sup>).

To clear the buffer, click on the percentage indicator.

### Analyzer State

The upper right corner of the main window will display the current state of the Analyzer using a "light Bulb" symbol and a short text message (next to the run buttons), while the lower right corner will display the state of the hardware as simple LED indicators with a letter abbreviation for a reminder.

### Message Example:



The 'Light Bulb' is lit, indicating that a trigger event occurred. The current status is "Post-Filling", indicating that the remainder of the buffer is being filled with post-trigger data.

### Indicator Example:



The status LEDs above indicate that the unit is powered, a trigger event has occurred and the remainder of the buffer is being filled with post-trigger data. Descriptions of each LED are provided below.

**P Powered** - The analyzer has been detected and is powered.

**H Halted** - The analyzer is 'IDLE' or waiting for a RUN command.

**P Pre Filling** - The analyzer is capturing data and filling the 'Pre-Fill' portion of the buffer.

**A Armed** - The analyzer is Armed and actively looking for a trigger condition.

**T Triggered** - The analyzer detected a trigger event.

**P Post Filling** - The remaining portion of the buffer is being filled with post trigger data.

**F Full Buffer** - The buffer is full.

**X Transferring** - The analyzer is transferring the compressed buffer to the PC.

The typical progression of the status indicators is from left to right.

## 3.2 Capture History

As data for a project is captured and transferred to the PC, it is stored on the Hard Drive as a history buffer and maintained according to the settings configured in Acquisition Options. Each project maintains its own history buffer in a sub folder using the same name as the project file. However, the project file does not require the history buffer to be present when opened. This allows the project file to operate as a 'stand-alone' file for sharing or archival purposes. When saving the project file, the currently loaded capture will be the data stored in the project (see also: [Acquisition Options](#)<sup>(53)</sup>).

### History Browsing

The history buffer can be accessed utilizing the History Menu, the Browse button or the bar graph. These items are located at the bottom of the main window. When browsing the history, the data for that history item will be loaded and all Signals, Auto Searches, Lists, Tables, etc. will refresh as if the data had just been captured.



### Menu Button

Click the Menu button to display the Capture History Menu:

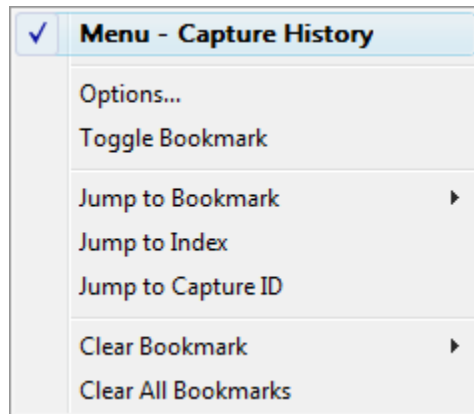

### **Browse Button**

A Left-Click or Right-Click on the browse button will load the previous or next item in the history buffer. Holding the mouse down will repeat the action in the same direction, causing an "Animation" of the history.

### **Search History Button**

Click this button to open the Capture History Search. This allows a search of the entire capture history using any normal search displayed in the Global search or the Search Manager (see History Searching below).

### **Bookmark Button**

Click the Bookmark button to toggle a bookmark for the current capture. If already bookmarked, then the bookmark is cleared.

### **Bar Graph**

Click on the bar graph to "jump" to different items in the history.

Click and drag the mouse in the bar graph to display the history item number to be loaded when the mouse is released.

The triangle in the bar graph indicates the current position in the buffer.

The small squares represent a bookmarked item which will also be listed in the history's menu for quick access.

The numbers in the top-left portion of the bar graph represent the Capture ID Number, the Position of the current capture in the buffer and the Total number of captures stored (in that order).

## **History Searching**

The entire captured history can be searched forward and backward to find a capture with a search result that matches the halt qualifier specified.

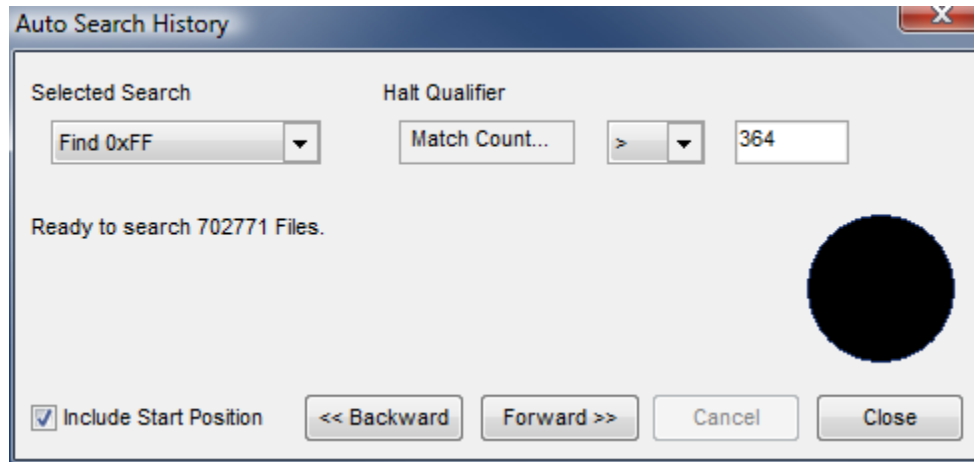

### Selected Search

Any search that you have defined for this project will be listed in the search selection drop-down box. Choose the search you want to use from this selection (see [Searches](#)<sup>91</sup>, [Searching](#)<sup>93</sup>).

### Halt Qualifier

Select the Logic (>, <, =, <>, <=, >=) and enter the count for the search to match. Most of the time you may be looking for any file that results in a single match or more and would set the logic to ">=" and the count to "1". However, you may be looking for the "odd" capture that has far fewer or greater matches than the other captures so we have allowed for values up to 32 bits to be specified for the count.

### Include Start Position

This option controls whether the search includes the file at the current position or not. Check this option to include the current position when the search begins (forward or backward). This box will be set automatically if the selected search is changed or on any changes to the halt qualifier. This option is automatically cleared when the search of a capture file results in a match, which saves you the trouble of manually clearing it if you re-start the search.

### Backward

This button starts the search from the current position and proceeds towards the oldest capture until a match is found or the oldest capture has been searched. The file at the current position is only searched when the "include start position" option is selected.

### Forward

This button starts the search from the current position and proceeds towards the newest capture position until a match is found or the newest capture has been searched. The file at the current position is only searched when the "include start position" option is selected.

### Cancel

This button stops the search.

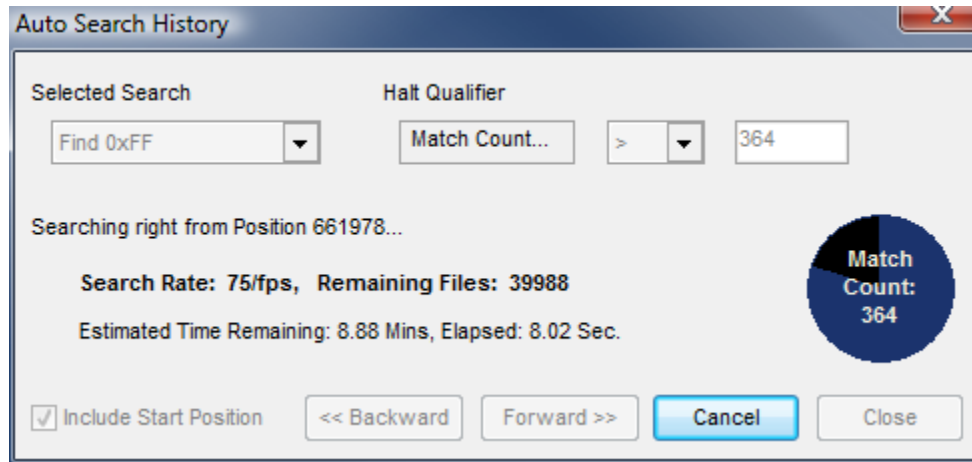

### Close

This button closes the search window. The close button will not be available if a search is in progress. Cancel the search if you want to close the window. When the window closes it will remember your current settings.

When the search is halted or stops automatically, the capture file at the stopped position will be loaded and all windows updated with the new data.

### No Matches found or Cancel example:



### Match found Example:

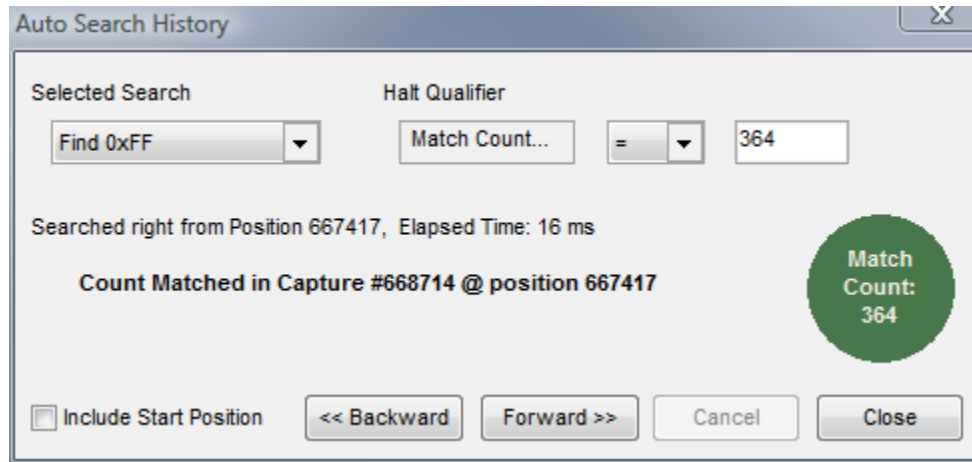

### 3.3 Capture Troubleshooting

Symptom	Causes & Solutions
<p>1. DigiView (Models DV3100 and DV3200) Power LED does not stay ON.</p>	<p>(A). The USB subsystem of the PC is turning DigiView Off due to a Bandwidth shortage.</p> <p>REMEDY: Remove other USB devices that use a port on the same hub (internal or external).</p> <p>(B). The USB subsystem of the PC is turning DigiView Off or DigiView is resetting due to insufficient power.</p> <p>REMEDY: If you are using an external hub, change to a POWERED external hub or purchase one of better quality that meets USB specifications.</p> <p>(C). The USB cable is not designed for High Bandwidth applications, causing communication errors.</p> <p>REMEDY: Replace the USB cable with one designed for the High Speed mode of the USB port.</p> <p>(D). The USB cable is connected to a case port that utilizes a low bandwidth cable internally, causing communication errors.</p>



Symptom	Causes & Solutions
	<p>REMEDY: Connect DigiView to a port located directly on the Motherboard (rear port of the case).</p>
<p>2. DigiView is only identified as a SERIAL device by the USB subsystem.</p>	<p>(A). The USB sub-system is experiencing a problem with corrupted or missing files.</p> <p>REMEDY: Look for a driver update to the USB hub (internal or external) or re-install its drivers. Refresh the DigiView drivers by re-installing the DigiView software.</p> <p>(B). Operating System or computer needs rebooted.</p> <p>REMEDY: Turn off the computer and re-boot the system.</p> <p>(C). The USB cable is not designed for High Bandwidth applications, causing communication errors.</p> <p>REMEDY: Replace the USB cable with one designed for the High Speed mode of the USB port.</p> <p>(D). The USB cable is connected to a case port that utilizes a low bandwidth cable internally, causing communication errors.</p> <p>REMEDY: Connect DigiView to a port located directly on the Motherboard (rear port of the case).</p> <p>(E). The DigiView hardware has been damaged.</p> <p>REMEDY: Call Technical Support for repair information.</p>
<p>3. One of DigiView's channels is connected to a transitioning signal, but the capture does not seem to show any activity or very little activity.</p>	<p>(A). The resolution of the Waveform View is too low to see the activity.</p> <p>REMEDY: Zoom In to see the details of the activity.</p> <p>(B). The signal has been defined with the wrong channel selected.</p>

Symptom	Causes & Solutions
	<p>REMEDY: Edit the signal definition and change the channel selection. The colors are repeated for each group of 9 channels, so be sure to select the correct one.</p> <p>(C). The signal definition has been "disabled".</p> <p>REMEDY: Edit the signal definition and uncheck the Disabled option. The channels for disabled signals will not appear in the captured data.</p> <p>(D). Bad Ground reference.</p> <p>REMEDY: Connect one of DigiView's ground wires (black probes) to a ground point as electrically close as possible to the signal connections.</p> <p>(E). Incorrect Trigger Threshold.</p> <p>REMEDY: The transitions will be undetectable if the trigger threshold is set too high or too low for the voltage range of the transitioning signal. Change the Threshold setting for the physical channel so that it is near the center of the signal's voltage swing.</p> <p>(F). Insufficient power or Communication error, see 1.B,1.C,1.D above.</p>

# Navigating and Analyzing the Data

**Part**



## 4 Navigating and Analyzing the Data

This is where you spend most of your time; trying to make sense of what you captured. You will find DigiView software very intuitive and easy to use but it is important to realize that **ZOOM operations occur about the CENTER of the screen**. The tools are all designed to take advantage of this fact to make you more productive.

The general paradigm is to find points of interest, bring them to the center of the screen and then ZOOM. We provide several methods of finding edges and bringing them to the center of the screen so that you can zoom in and out without having to constantly scroll to 'zero-in' on the point of interest.

### Navigation, Markers & Buttons:

[Waveform Views](#) <sup>[72]</sup>

[Using Markers](#) <sup>[75]</sup>

[Marquee Zoom](#) <sup>[79]</sup>

[Toolbar Buttons](#) <sup>[79]</sup>

[Bird's-Eye View](#) <sup>[81]</sup>

[Hot-Keys](#) <sup>[82]</sup>

### Viewing the Data in Time-Relative Columns:

[Table Windows](#) <sup>[84]</sup>

[List Windows](#) <sup>[87]</sup>

### Linking Views into Time-Relative Groups:

[Using Link Groups](#) <sup>[90]</sup>

### Searching the Data:

[Search Overview](#) <sup>[91]</sup>

[Define Searches](#) <sup>[91]</sup>

[Searching](#) <sup>[93]</sup>

[Search Manager Windows](#) <sup>[93]</sup>

[Search Types](#) <sup>[96]</sup>

## 4.1 Waveform Views

Wave Form views are the central focus of navigating and analyzing the huge amount of captured data. In the waveform views you can Zoom quickly to different resolutions (without throwing data away), snap to edges or beginning of packets, drop markers to correlate time between transitions and much more.

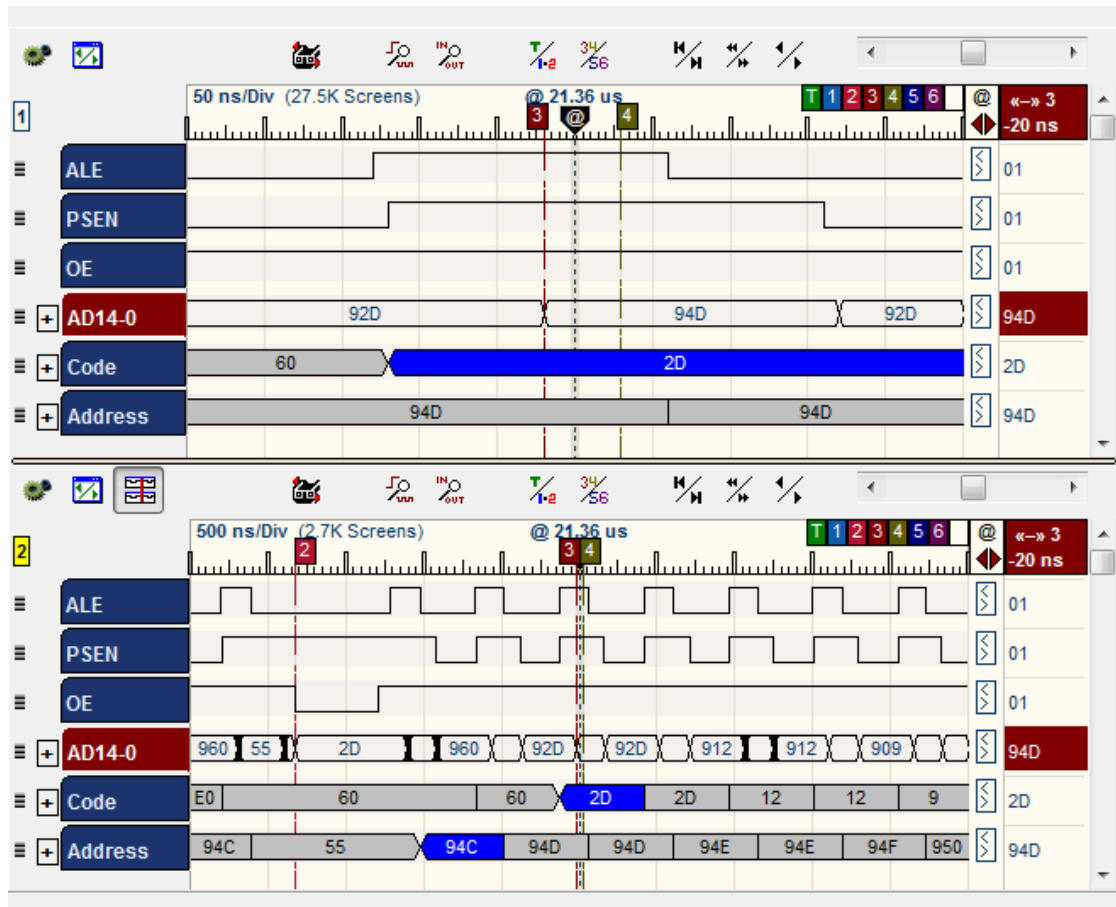

### Waveform View Function Summary

View multiple signals in time correlation.

**Expand** Multi-Channel Signals to see individual channel waveforms by using the "+" symbol to the left of the signal name.

Individually reverse **Expand Order** of Multi-channel signals by menu.

**Collapse** expanded Multi-Channel Signals by using the "-" symbol to the left of the signal name.

**Zoom** in or out for more or less resolution.

Single button **Zoom Max** resolution or **Zoom Min** resolution.

**Marque to Zoom** function. (see: [Marque Zoom](#)<sup>[79]</sup>)

**Scroll** by a single division or **Page** multiple divisions.

**Free Scroll** vertically and horizontally by a Right-Click Drag.

**Link** both Waveform Views at the center time for **Synchronous Scrolling** regardless of each view's zoom level. (see: [Using Link Groups](#)<sup>[90]</sup>)

**Drop Marker** arbitrarily by Ctl-Drag or Drag & drop in the topmost row.

**Snap Markers** to next or previous transition of a signal by Drag & drop. (see [Cursors and Markers](#)<sup>[75]</sup>)

Snap Markers to next or previous transition and **Bring to Center** by Shift-Drag.

**Snap Signal** to the next or previous transition by using the " <, > " indicators to the right of the signal.

**Arbitrary Snap to center** and **Edge Snap to center** by a Left-Click anywhere on a signal.

**Set, Clear** or **Jump** to markers.

**Signal Row Order** can be re-arranged by dragging.

**Bus Signal Format** can be set to HEX, Decimal or Octal.

Independently select which signals to view in each Waveform View.

**Edit Signal Properties** by menu or Left-Click on the signal's name. (see: [Signal Editors](#)<sup>[9]</sup>)

**Print** current Waveform View or **Save as JPEG**. (see: [Printing](#)<sup>[12]</sup>)

### Waveform Pop-UP Menus



To access the main waveform menu, click the menu button (shown on the left), the topmost row or the left column of the waveforms. To access a signal specific menu, Right-Click on a Signal name.

#### Waveform Menu:

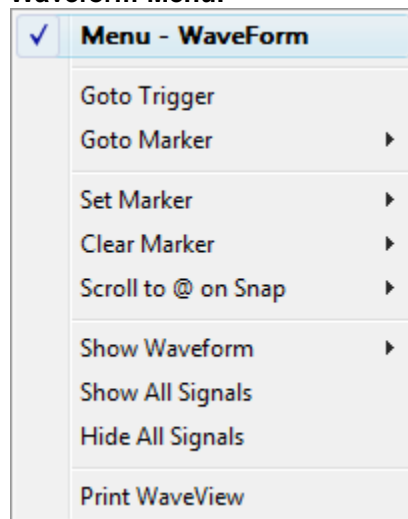

#### Waveform Signal Menu:

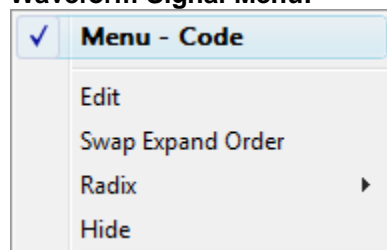

## 4.2 Using Markers

### Markers

Six markers (M1, M2, M3, M4, M5, M6) are provided. Markers have several uses. They can be used to measure time or signal specific measurements, to 'bookmark' locations and to help bring data to the center of the screen.

The Status window shows the current time of each marker (relative to TRIGGER) as well as additional information for the current capture.

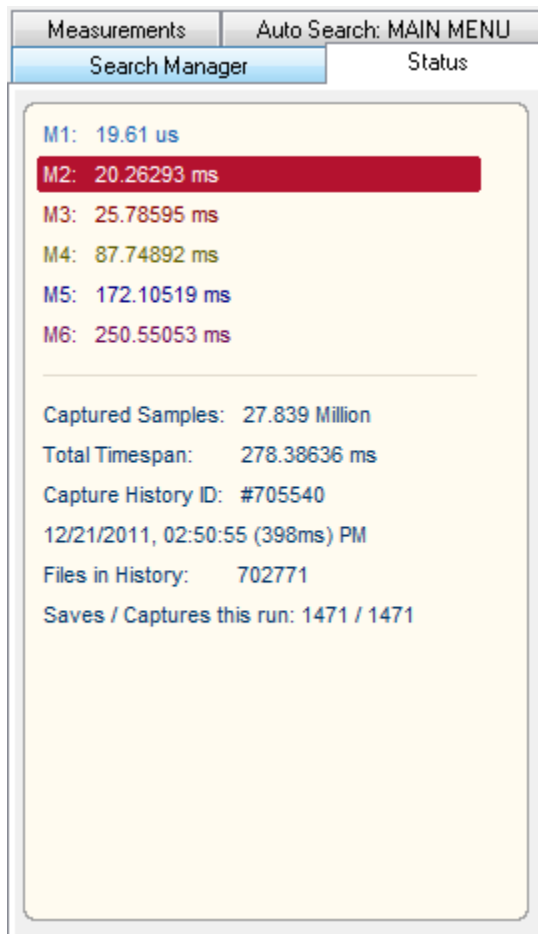

Whenever a marker becomes the Active Marker, its corresponding information will automatically highlight in the Status Window and if assigned to a signal (assigned = being dragged over a signal or dropped on one in the Waveform View), measurements for the signal are displayed for adjacent marker pairs in the Measurements Window. The measurement displayed is determined by the type of signal the active marker is assigned to.

In the image below, marker "M3" is the active marker and it is assigned to an Asynchronous signal definition named "ASYNCTX".

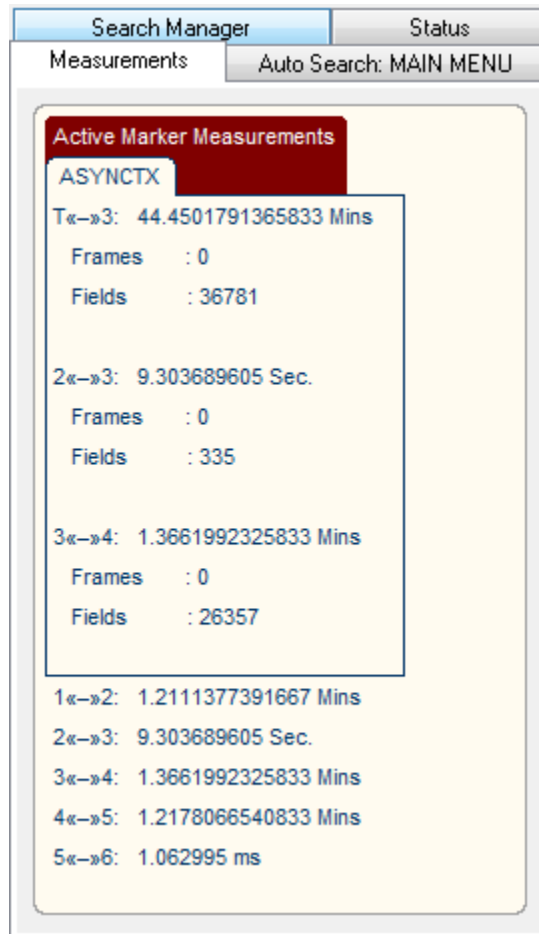

### Drag to place

Simply click on a marker and drag it to the area of interest. You can grab the marker itself (the vertical line in the waveform area) or its 'flag' (the rectangle at the top of the window). Notice that the flags are offset so that even when they are overlapped, you can still grab them. When your mouse is in the capture zone for a marker, the cursor changes to indicate that it is over a marker. The cursor also indicates which marker would be selected, making it easier to grab a specific marker when they are very close together (or even on top of each other).

### Quick Select Flags

Sometimes markers are invisible, buried behind other markers or off-screen. You can easily grab any marker from the quick-select flags at the top right corner of the window, regardless of their current position or visibility.



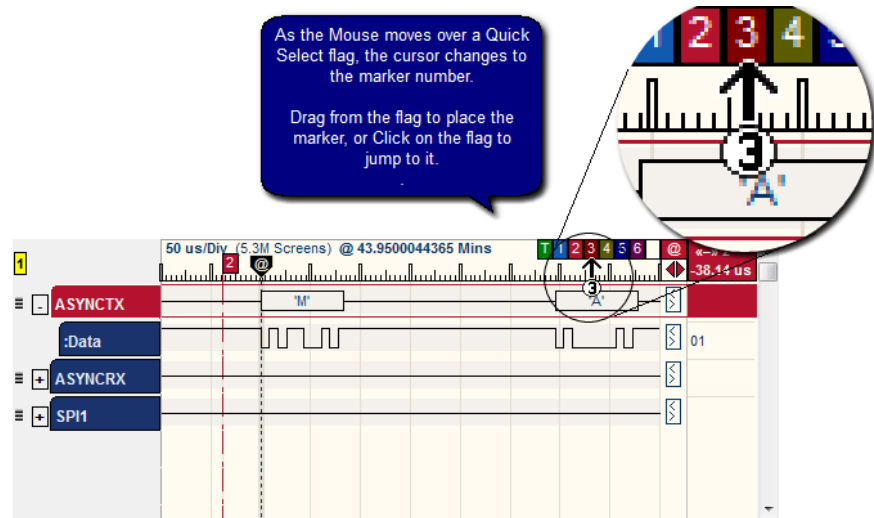

**Dragging** from these flags will bring the marker to the current screen position and make it visible if necessary.

**Clicking** on one of these flags will automatically scroll the waveform view to the markers position and center it in the waveform window. This can also be referred to as "**Jump to Marker**".

**Auto-Snap**

'Snapping' the markers to signal edges makes it easy to measure the time between them or to bring a specific edge to the center of the window. This operation is used so often that we optimized it by making it an automatic function. When you are dragging a marker and your mouse is over a waveform, the cursor changes to a 'snap-left' or 'snap-right' arrow. The direction of the arrow shows you which edge (previous or next) of this waveform the marker will 'snap' to if you were to drop it at that point. The arrow will point to the nearest edge or to the nearest edge in the direction of mouse movement, even if that edge is off-screen.

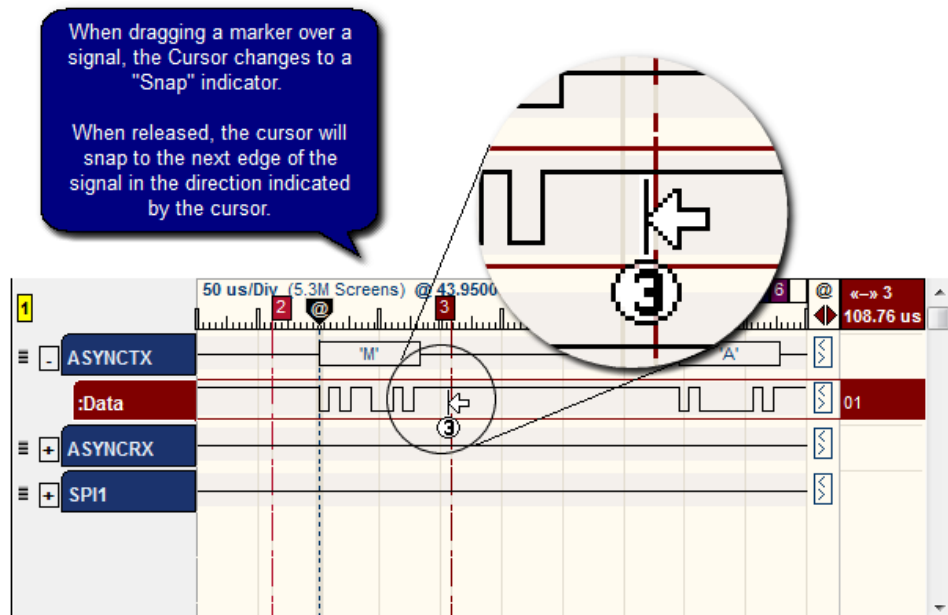

If you do NOT want to SNAP, but rather wish to drop the marker exactly at the mouse position, you can either hold down the control key or move your mouse above or below all waveforms before releasing the mouse button.

### Auto-Snap & Bring to Center

Hold the SHIFT key when 'Snapping' the markers to force the "snapped-to" edge to the center of the screen.

### Drop & Bring to Center

Hold both the SHIFT key and the CTRL key when dragging a marker to "drop" the marker and bring the drop point and marker to the center of the screen.

### Right Click Popup

Right clicking on the name of the signal (or in the top margin) opens a pop-up menu with easy access selections to bring a marker to the center of the window, or to clear one or more markers. This provides another method of Setting, Clearing and Jumping to markers. If you click on the signal's name, then this popup menu will also include signal specific options.

### Active Marker

Any action that uses a marker will automatically designate that marker as the "Active Marker". The active marker exposes additional properties and associated items for easier navigation and support to 'bring the data to center' concept.

### Waveform Association

When you snap a marker to a waveform, it becomes associated with that waveform as indicated by the usage of the marker's color in the Active Marker Column on the right. In the image below, Marker M2 is associated with ASYNCTX and the value of ASYNCTX at the marker position is 'E' as shown in the Active Marker Column.

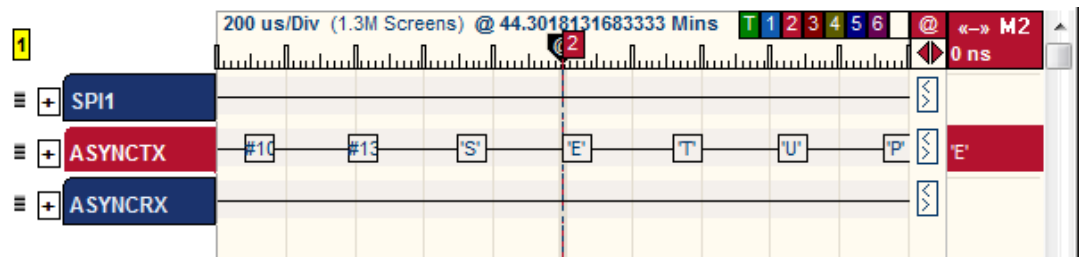

To associate the Active Marker to another signal, click in the Active Marker Column of the signal. To SNAP the Active Marker to the next edge of the signal after it is associated, right or left click in the active marker column of the associated signal (or use the Snap Left/Right button)

### Snap Left/Right

To snap the active marker to the previous or next edge of the associated waveform, either right or left click in the Active Marker Column or on the dedicated snap button next to the Active Marker Column's marker identifier. In the image above the identifier is "2" and the dedicated button is the same color as marker M2.



This allows one to walk any marker from edge to edge on a specific signal. To walk through two different sections of data or two different signals, simply select each desired

marker using the Quick Select flags. Each marker maintains its position, allowing one to jump back and forth between them. You can walk one signal for a while, jump to the other marker and walk that signal and then jump back to the first marker and pick up where you left off.

Left-Click to Snap Left.  
Right-Click to Snap right.

### Marker Tack

The button just above the Active Marker's snap button will toggle the "Tack" feature of the marker. When the button is pressed tacking is enabled. When the Tack option is active, snapping the marker will bring the data to the position of the '@' time reference instead of moving the marker out of view. When tacked, the button displays in the same color as the active marker.



You can still drag the marker (with or without auto-snap) to another point in the data, but when you release the mouse button, the marker AND the data will be brought to the center of the screen, ready for zooming in/out.

TACKing a marker is particularly useful for walking though a signal, edge by edge. Normally, when you SNAP the a marker, the marker moves to the previous or next edge of the associated signal. When the marker is tacked, the DATA is brought to the MARKER (and the screen's '@' time reference). This allows you to walk through the data without continually re-centering the screen. It also supports our 'bring the data to the center..THEN zoom' paradigm.

Note that this is an intelligent TACK. It does NOT freeze the marker at the screen center. It brings the marker to center any time you move the marker (by dragging, snapping or setting its position). This allows the marker to stay at a specific TIME/EDGE if you scroll the screen or jump to another marker. The next time you attempt to move the TACKed marker, it will move relative to the place you left it, then bring it and the data to the window's center. For example, we will assume that you have enabled the Tack option for both M1 and M2 markers. While you are moving/snapping the M1 marker, it stays as the center. You can jump to the M2 marker and it starts tacking at the center. At any time, you could jump back to the M1 marker (by clicking on the Quick Select flags in the upper right corner).

## 4.3 Marquee Zoom

You can use your mouse to marquee an area of data to zoom in on. Click and drag to marquee a section. When you release the mouse button, the enclosed area will pan to the center of the screen and then zoom in as much as possible while keeping the entire area on the screen.

## 4.4 Toolbar Buttons

We make extensive use of the right mouse button. Most functions have naturally paired

operations. Most paired functions are natural opposites (like left/right, in/out, first/last, previous/next). Others are not opposites but still naturally paired (like X/Y). We take advantage of this symmetry to double up the functions of most buttons and other clicks. This not only reduces desktop usage but also results in more natural, easier to remember functions.

For example, rather than having separate SEARCH LEFT and SEARCH RIGHT buttons, we have a SEARCH button. Left clicking the button will SEARCH LEFT; right clicking will SEARCH RIGHT.

After only a few minutes of use, this becomes much more natural than using separate buttons. Switching directions involves pressing different mouse buttons rather than moving the mouse to a new button in the application. All buttons in the tool bar above the Waveform View are dual-function. Additionally, you will find that left and right clicking on the "<" and ">" symbols, Active Marker column and various other buttons will perform similarly paired functions.



### **Goto Trigger / Goto M1+M2**

Left Click - Go to the Trigger Point Cursor

Right Click - Go to the midpoint of the M1 and M2 Marker, then Zoom to Fit in view



### **Goto M3+M4 / Goto M5+M6**

Left Click - Go to the midpoint of the M3 and M4 Marker, then Zoom to Fit in view

Right Click - Go to the midpoint of the M5 and M6 Marker, then Zoom to Fit in view

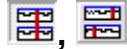

### **Link / Unlink Waveform Views**

Down Position - Waveform views are LINKED for Synchronized Scrolling (first graphic above)

Up Position - Waveform views are NOT linked, allowing independent scrolling (second graphic above)

When Linked, all members of Link Groups 1 and 2 will also be linked. (see: [Using Link Groups](#))



### **Previous View / Next View**

Left Click - Navigate backward in the waveform view's Scroll & Zoom history.

Right Click - Navigate forward in the waveform view's Scroll & Zoom history (if you have already navigated backward).



### **Scroll by 1**

Left Click - Scroll left by 1 division. LEFT means to scroll the view window to an earlier point in time. (hold to repeat)

Right Click - Scroll right by 1 division. Right means to scroll the view window to a later point in time. (hold to repeat)



### **Scroll by 5**

Left Click - Scroll left by 5 divisions (1/2 screen) (hold to repeat)

Right Click - Scroll right by 5 divisions (1/2 screen) (hold to repeat)



### **Scroll Start/End**

Left Click - Scroll to START of data

Right Click - Scroll to END of data



**Search**

Left Click - Search Left to previous match using selected Global Search  
 Right Click - Search Right to next match using selected Global Search



**Search Edit**

Click to Edit selected Global Search



**Waveform View**

Click to change Waveform view to SINGLE or SPLIT view



**Zoom In/Out Max**

Left Click - Zoom IN ALL the way (Highest Resolution)  
 Right Click - Zoom OUT ALL the way (show ALL data)



**Zoom In/Out**

Left Click - Zoom IN one step (more detail, more resolution) (hold to repeat)  
 Right Click - Zoom OUT one step (less detail, less resolution) (hold to repeat)

**4.5 Bird's-Eye View**

The BirdsEye window gives you the really big picture. It shows the relative zoom and position of the two waveform windows and the total data. The total data is show with a horizontal line down the middle and 'goal-post' lines on the ends. The primary waveform window is represented with a different color (lighter in this example) rectangle in the top half of the display. Likewise, the secondary waveform window (if visible) is represented in the bottom half of the window.

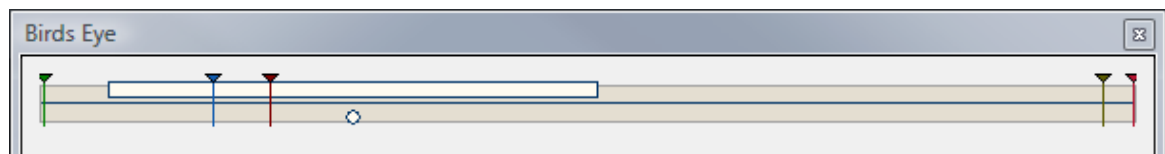

When the window is zoomed in on a small percentage of the data (usually the case) the waveform representation becomes a small circle so that you can still see it. Otherwise it would degenerate into a very thin line.

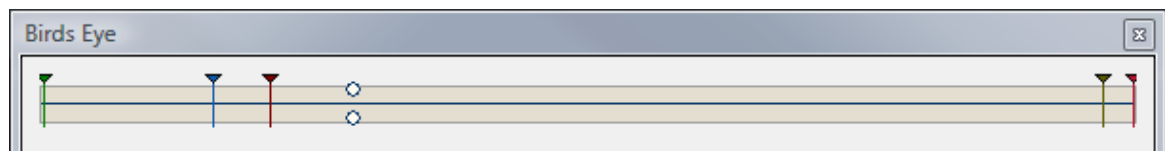

As you navigate through the data, you can look at the BirdsEye to see exactly where you are in the data and how fast you are progressing through it. When you have both waveform windows open you can see their relative zoom levels as well as positions. If they are linked to each other, you will notice that they move together through the data.

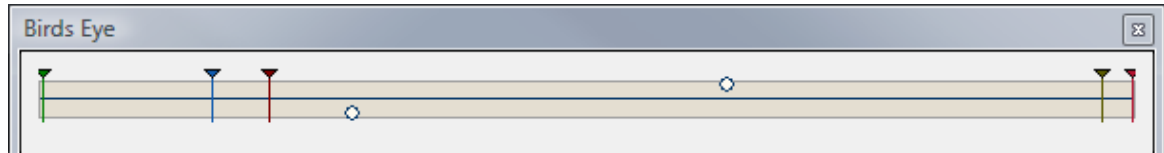

Each of the markers are also shown with color-coordinated lines.

You can click on the BirdsEye window to position a waveform window in the area of the data clicked on. If the secondary waveform window is open, then clicking in the bottom half repositions the secondary waveform. If you click near one of the markers, the waveform will "snap" to the markers position. Clicking in the top half repositions the main waveform. If the secondary waveform is not visible, then clicking anywhere in the window repositions the primary waveform window.

Press and hold the 'I' or 'O' keys to see the affect on the bird's-eye while zooming in and out. In the example below, the top waveform view is zoomed to a large portion of the available data and the lower waveform view is zoomed out far enough to see all the data. The data is represented by the taller rectangle (darker color in this example).

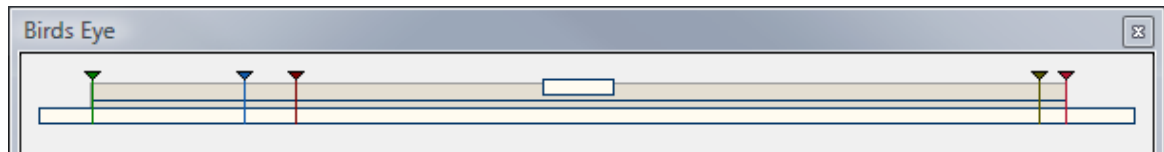

## 4.6 Hot-Keys

The HOT-KEYs are not expected to replace a mouse, but rather, supplement it. When analyzing lots of data, it can be useful to use the keyboard for say, ZOOMING and SCROLLING while using the mouse for cursor control.

### **1, 2, 3, 4, 5, 6**

(without shift) GOTO marker (M1, M2, M3, M4, M5, M6)

(with SHIFT) SETS marker (M1, M2, M3, M4, M5, M6) to the current '@' time reference.

### **I,O**

(without SHIFT) Zoom IN/OUT one step (hold to repeat)

(with SHIFT) Zoom MAX IN/OUT

### **P**

Preview (initiate a repeated, short capture, ignoring trigger criteria)

### **A**

Auto Run (initiate a repeated capture, honoring all trigger criteria)

### **R**

Run (initiate a capture, honoring all trigger criteria)

### **S**

Stop (stops a capture, transfers available analyzer buffer to the PC)

**H**

Halt (stops a capture, discards any partial buffer in the analyzer)

**T**

GOTO Trigger point

**Z**

Zoom and pan to bring both markers M1 & M2 into view

**<, >**

(without SHIFT) Scroll LEFT or RIGHT 1 division (hold to repeat)

(with SHIFT) Scroll LEFT or RIGHT 5 divisions (1/2 screen) (hold to repeat)

**[ , ]**

Scroll to START or END of data

**Ctrl+Drag Window**

Holding the control key while dragging a window will temporarily turn off the docking prompts so a window can be positioned without docking.

**Shift+Snap**

Holding the shift key, while snapping a signal or the active marker to the next data change in the waveform view, will toggle the snap between Field/Frame modes (depending on the "Snap to Frames" environment setting). This option is only available when framing information is contained within the signal.

**Alt+F**

Open the FILE menu

**Alt+C**

Open the CONFIG menu

**Alt+S**

Open the SEARCH menu

**Alt+W**

Open the WINDOW menu

**Alt+H**

Open the HELP menu

## 4.7 Table View Windows

Table views present the data as a list of numbers (tabular form). Table windows can be created after a signal of any type is created. To create a Table view, select any of the signals presented on the **New Table** submenu of the **Window** menu. Some signals in the menu will have "(raw)" appended to the signal name. These signals can be added to a Table view in their raw data format, but are better viewed in their decoded format using a List view. (see: [List Views](#)<sup>[87]</sup>)

Time: ms	ALE	AD14:
-0.00008	1	094C
-0.0001	0	094C
-0.00001	0	0964
-0.00024	0	0960
-0.00011	1	0960
-0.00008	1	094D
-0.00011	0	094D
-0.00024	0	092D
-0.00011	1	092D
>0.02134<	1	094D
0.00008	0	094D
0.00011	0	092D
0.00025	1	092D
0.0001	1	094E
0.00009	0	094E
0.0001	0	0912
0.00025	1	0912
0.0001	1	095A
0.00001	1	094F

- Multiple tables can be created and viewed simultaneously.
- Multiple signals can be viewed with each signal in a separate column.
- Multi-Channel Signals can be "expanded" to multiple columns.
- Expand order of Multi-channel signals can be reversed.
- Signal column order can be re-arranged by dragging.
- Bus Signals can be formatted as Binary, HEX or Decimal.
- Time Display can be set to Auto, ns, us, ms, sec, min, hrs, days or weeks.
- Time Format can be set to Delta or Absolute.



Time Column can be hidden.

Set, Clear or Jump to markers. (see [Cursors and Markers](#)<sup>[75]</sup>)

Assign Time Synchronized Link Group. (see: [Using Link Groups](#)<sup>[90]</sup>)

Select which Signals to view in each Table.

Edit Signal Properties. (see: [Signal Editors](#)<sup>[9]</sup>)

Print current Table View or Save as JPEG. (see: [Printing](#)<sup>[12]</sup>)

Export data using Table's settings. (see: [Exporting Tables](#)<sup>[11]</sup>)

While most manufacturers provide table views, they generally are not too useful for anything other than STATE mode signals. Most logic analyzer demos will show data changing on every sample, making the table view look interesting in timing mode. However, in real usage, most signals do not change at anywhere near the sample rate, causing the table to show a small sample of stable data. You might have to scroll several screens before seeing the signal transition. We have added several enhancements to the basic table view to make them truly beneficial in real-world usage.

### Compressed View

This mode compresses out the 'dead-time' between transitions, packing a lot more information into a screen of table data. Each line of data in the table contains the timestamp and the data. The time between lines varies and corresponds to the length of time the previous sample was stable. In this mode, a 40 line table contains 40 transitions. In linear (non-compressed) mode, it would contain 40 SAMPLES with perhaps NO transitions. If multiple signals are added to the table, the compression algorithm takes ALL signals in to account. A new line is shown any time ANY of the signals change state. Nothing is lost or thrown away. We simply compress out the redundant information, making the table hold more significant data. You can switch between compressed and linear views with a single click at any time.

Although compressed mode is the most efficient way to display a signal in tabular form, some people have trouble visualizing the non-linear, compressed time. You can Link a compressed table with other non-compressed tables or with waveform displays to correlate the data to a linear view. This allows BOTH an efficient table view and a linear 'in-context' view.

The included '8051.dat' example demonstrates this well. The OE signal in that example is spread across about 1.4 Million samples but can be displayed in less than 20 table lines when compression is enabled. When this table is linked to a waveform view, scrolling through this small table quickly scrolls the waveform to each significant event in the OE signal. This is a real-world example captured from a real embedded system.

### Down Sampled View (Zoom)

Another approach to making the table view useful in normal timing modes is to use down-sampling. This mode presents the data in a time-linear format, but down-samples the data to reduce information. Down-sampling preserves linearity but reduces resolution. This is similar to turning down the sample rate while capturing data to extend capture times at the expense of resolution. Of course the key difference is we are post processing the data for the table view; not ignoring data during capture. In this mode, we are simply displaying the data with less resolution to allow the user to see more transitions while maintaining a linear time view. Since we have not changed the underlying data itself, you can 'zoom in' (reduce down-sampling) at any time to see more detail and actual timing. You can also link to other full-resolution tables or waveforms to get a simultaneous view of

the full detail and the data's correlation to other signals.

### Delta vs. Linear time

Regardless of the display mode( normal, compressed or down-sampled), you can display the time field in absolute or delta time. Absolute is the actual timestamp of the sample (relative to trigger). DELTA mode shows the time between table lines. This is most useful in compressed mode where it tells you the time between transitions. In normal and down-sampled modes, it simply tells you the sample rate( since the time between each line is constant).

### Table Menu

The table's menu offers several useful functions such as navigating to a reference point, adding additional signals, configuring the time and so forth. To activate the menu for a specific signal from within the table, right-click in the signals' column. Examples of these menus are displayed below.

#### Table General Menu:

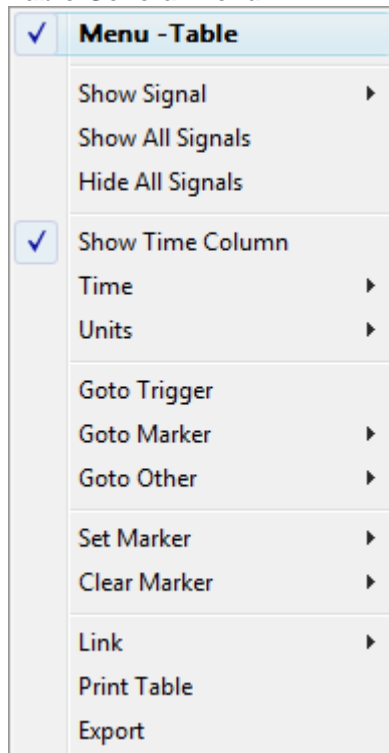

#### Table Signal Menu:

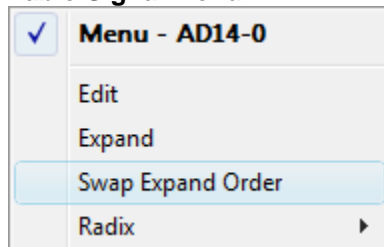

## 4.8 List View Windows

List views present the decoded data of higher level signal types in column form. List windows can be created after creating a signal definition that supports decoding (such as I2C). All signals that use decoding or any Plugin signal can be displayed in the List window. The only signals that can not display in the List window are Bool, Bus and Analog. To create a List view, select any of the signals presented on the **New Decoded List** submenu of the **Window** menu. These signals can also be presented in their raw data format using a Table view. (see: [Table Views](#)<sup>[84]</sup>)

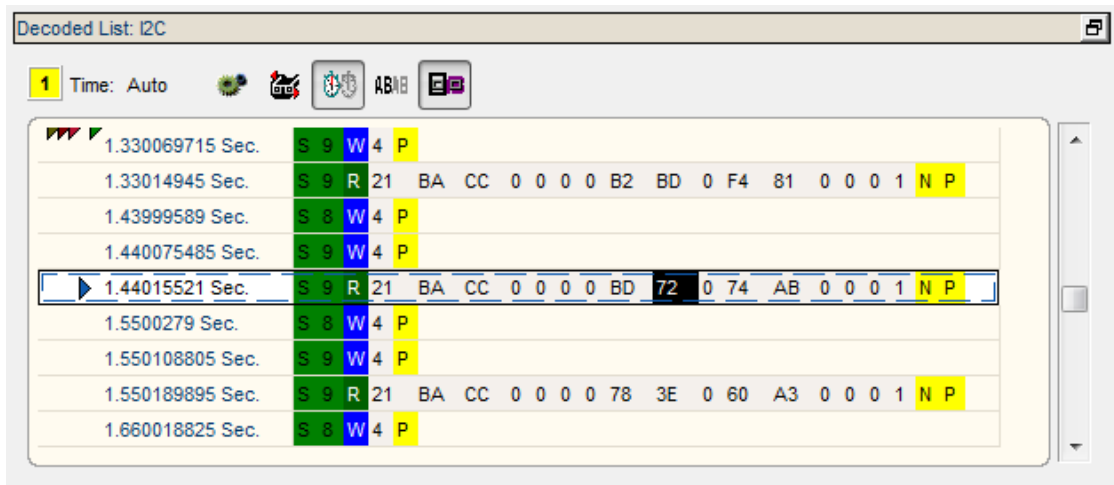

- Multiple lists can be created and viewed simultaneously.
- Time Display can be set to Auto, ns, us, ms, sec, min, hrs, days or weeks.
- Time Format can be set to Delta or Absolute.
- Time Column can be hidden.
- Set, Clear or Jump to markers. (see [Markers](#)<sup>[75]</sup>)
- Assign Time Synchronized Link Group. (see: [Using Link Groups](#)<sup>[90]</sup>)
- Select which Signal to view in each List.
- Edit Signal Properties. (see: [Signal Editors](#)<sup>[9]</sup>)
- Print current List View or Save as JPEG. (see: [Printing](#)<sup>[12]</sup>)
- Export data using List's settings. (see: [Exporting Lists](#)<sup>[116]</sup>)

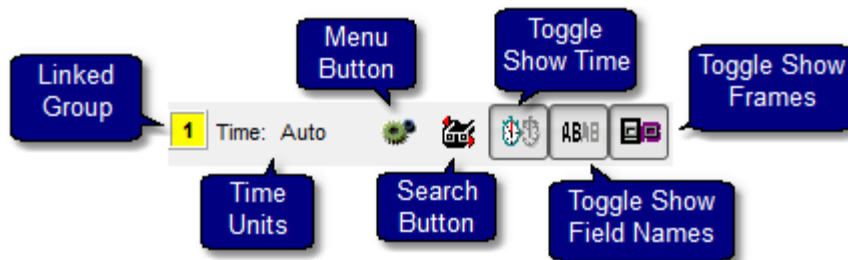

List Views have several options to change what data to display and how the data is displayed. These options are accessible from the top bar in the window and can be used in combination. Some examples of the display options are shown below using an I2C signal.

#### Time Column:

Decoded List: I2C

1 Time: Auto

1.440078055 Sec.	9
1.44009696 Sec.	W
1.44011347 Sec.	4
1.44014734 Sec.	P
1.44015521 Sec.	S
1.4401578 Sec.	9
1.440176695 Sec.	R
1.440188725 Sec.	21
1.44022046 Sec.	BA
1.44025213 Sec.	CC

#### Time Column, Name:

Decoded List: I2C

1 Time: Auto

1.440078055 Sec.	Addr	9
1.44009696 Sec.	WRITE	W
1.44011347 Sec.	Data	4
1.44014734 Sec.	STOP	P
1.44015521 Sec.	START	S
1.4401578 Sec.	Addr	9
1.440176695 Sec.	READ	R
1.440188725 Sec.	Data	21
1.44022046 Sec.	Data	BA
1.44025213 Sec.	Data	CC

#### Time Column, Name, Frames:

Decoded List: I2C

1 Time: Auto

Time	START	Addr	WRITE	Data	STOP
1.43999589 Sec.	S	8	W	4	P
1.440075485 Sec.	S	9	W	4	P
1.44015521 Sec.	S	9	R	21 BA CC 0 0 0 0 BD 72 0 74 A	
1.5500279 Sec.	S	8	W	4	P
1.550108805 Sec.	S	9	W	4	P

Frames:

Decoded List: I2C

1 Time: Auto

S	9	W	4	P
S	9	R	21	BA CC 0 0 0 0 B2 BD 0 F4 81 0 0 0 1 N P
S	8	W	4	P
S	9	W	4	P
S	9	R	21	BA CC 0 0 0 0 BD 72 0 74 AB 0 0 0 1 N P
S	8	W	4	P
S	9	W	4	P
S	9	R	21	BA CC 0 0 0 0 78 3E 0 60 A3 0 0 0 1 N P
S	8	W	4	P

Menu:



## 4.9 Using Link Groups

Link groups provide **Synchronous Scrolling** of a group of windows that display data. When several windows are part of the same Link Group, each window will automatically update and scroll when any member of the group changes its center time. The time reference and displayed data of each member will "center" on the time the changing member centers on. This feature keeps a group of windows synchronized to the same time in the captured data.

DigiView provides five link options that include Link Groups 1 through 4 and a "no-link" option for windows that you want to keep independent.

Default link groups:

**Link Group 1** - Waveform View 1 is always a member and all new windows initially belong to this group.

**Link Group 2** - Waveform View 2 is always a member of Link Group 2.

**Link Group 3** - Empty Group, ready for members.

**Link Group 4** - Empty Group, ready for members.

The link group of any window that displays data (such as Tables and Lists), can be changed at any time. To change the group in these windows, select the window's menu, then choose the desired option from the submenu of the "Link" item. The options on this menu are displayed in the following Graphic.

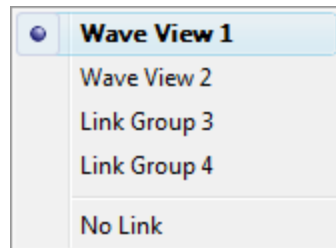

All windows or views that can be assigned to a link group, will have a visible indicator with the group number or an " \* " (asterisk) displayed. The asterisk indicates an independent window that is not linked to any group.

Typical Link Group indicators:



NOTE: When Waveform View 1 is "cross-linked" to Waveform View 2, all members of Link Groups 1 and 2 will also be cross-linked. Waveform Views are cross-linked by using the Link button at the top of Waveform View 2. (see [Waveform Views](#)<sup>[72]</sup>, [Toolbar Buttons](#)<sup>[79]</sup>)

## 4.10 Searches

When analyzing the captured data, the ability to search forward and backward for specific pattern matches or packet values is indispensable. DigiView provides a general search type for pattern matches, a Sequential Frame and sequential Field search for parsed signals and a Search Manager to quickly perform multiple searches and change criteria. The following sections provide details of DigiView's searching capabilities.

[Defining Searches](#)<sup>[91]</sup>

[Performing a Search](#)<sup>[93]</sup>

[Using the Search Manager](#)<sup>[93]</sup>

[Auto Search Windows](#)<sup>[94]</sup>

[DigiView's Search Types](#)<sup>[96]</sup>

Searching Capture History (see [Capture History](#)<sup>[64]</sup>)

### 4.10.1 Define Searches

New searches are defined by clicking on the "**Search->new**" menu item and selecting the signal

to search from the submenu. Depending on the type of signal selected, a Pattern Search or Sequential Search will be created and its editor window will automatically open. For example, if you have selected a signal of type "I2C", then the Sequential search type will be created. (For details on each search type, see: [Search Types](#)<sup>[96]</sup>).

After a search is created it will be available in the [Search Manager](#)<sup>[93]</sup> and all search selection windows, including selection for [Auto Search](#)<sup>[94]</sup> windows and searching the [Capture History](#)<sup>[64]</sup> files.

All search types (and therefore all search editors) have the following common properties.

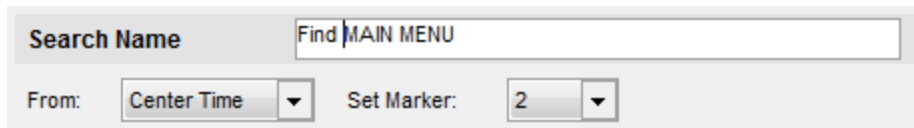

The screenshot shows a search editor window with the following fields:

- Search Name:** Find MAIN MENU
- From:** Center Time
- Set Marker:** 2

#### **Search Name** - Description

Use the Name field to describe the search. This descriptor will be displayed in the Search Manager Windows and in the Global Search selection box.

#### **From** - Where to begin Searching

The 'search from' selection determines where the search starts from; the current center of screen or the current marker location. Since the marker is placed at the center of the screen after the first search match, these are often the same during consecutive searches. The main difference occurs during the first search or between searches if you scroll the screen.

#### **Set Marker** - Mark the match point

The marker selection determines which marker is used to show the search match. You must select one. Whenever the search matches, the selected marker is placed at the match point and then centered in the searched window.

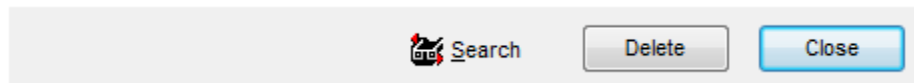

#### **Delete Button** - Deletes this search

Use the Delete button to dispose of the search and remove it from all search managers.

#### **Close Button** - Closes this search editor window

Use the Close button when you are finished making changes and want to close the editor for this search.

#### **Search Button** - Performs this search

Use the Search button to test the settings you have just entered for this search. Right-Click to search forward from the current time of the marker. Left-Click to search backward from the current time of the marker. When you are satisfied with the search settings, you can close the search and use any search button in the application to continue searching. (see: [Searching](#)<sup>[93]</sup>)



## 4.10.2 Searching

### Search Button

Left clicking on a search button searches back in time (previous match.) Right clicking on a search button searches forward in time (next match.) See ['Define Searches'](#)<sup>[91]</sup> for details on creating searches.

### Invoking Searches

There are several methods of invoking a search. Each presents a slightly different way of selecting the search and the target window, but they all perform the search in the same manner.

If the search is configured to search 'from center time', then the search starts from the center time of the FOCUSED window (possibly the last match). Otherwise the search starts from the search's marker position (possibly the last match). In either case, the marker is positioned at the location of the search match and then the FOCUSED window is centered on the marker. If the window is part of a link group, then the entire link group is centered as well (see: [Link Groups](#)<sup>[90]</sup>). The center time of the FOCUSED window does not change if the search fails.

Regardless of how the search is invoked, we actually always run the DEFAULT search on the FOCUSED windowed. We simply CHANGE the DEFAULT search or the FOCUSED window before running the search in some cases. This creates a very consistent environment where you can jump from one search button to another without surprises. The last invoked search is always the current DEFAULT search and the last searched window is always the currently FOCUSED window (until you do something to change it), regardless of how the search was initiated.

### Global Search Find MAIN MENU

Beside the search selection box and search edit button is a SEARCH button. This search button performs the Active Search, using the currently FOCUSED window as described without changing either.

### Local Search

Each Data Table, List and Waveform window has a local search button. When you click on a window's local search button, that window becomes the FOCUSED window and then the search is applied to it as usual (using this newly FOCUSED window). Clicking on a local search button is the same as clicking anywhere on a waveform or table to FOCUS it and then clicking on the Global Search button.

### Search Manger Searches

When you click on a search button in the search manager, the DEFAULT search is changed to that button's search and then the search is performed as usual (using this new DEFAULT search). This has the same results as selecting the button's search from the Default search selection pull-down and then clicking on the Global Search button. (see: [Search Manager](#)<sup>[93]</sup>)

## 4.10.3 Search Manager Windows

The search manager window shows a list of all defined searches (see: [Define Searches](#)<sup>[91]</sup>). It also provides an easy method of executing or editing any of the searches. This is particularly useful if you need to do a series of searches involving different search types.

To create a search manager, select "**New Search Manager**" from the **Window** menu. Multiple search managers can be created.

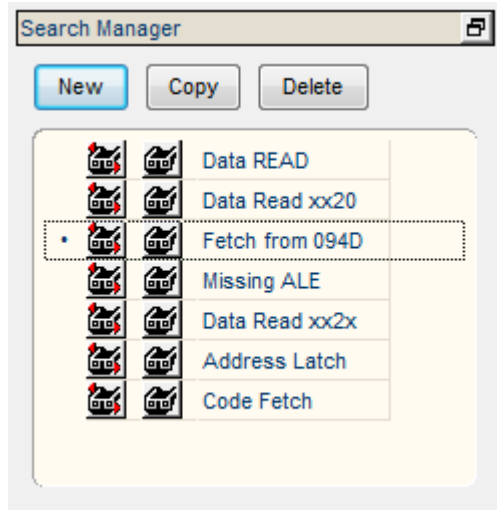

**Search** - Each entry in the list includes a Search button in the left column. Left-click or Right-click on the Search button to perform that search as described in the '[Searching](#)' section.

**Edit Search** - Each entry in the list includes an Edit button in the second column. Click on the Edit button to edit the parameters of a defined search.

**Set as the Active Search** - Click on the search name itself or use either of its buttons in the search manager and the search will automatically become the Active (or Global) search. Any search button in the program will perform the Active search.

**New** - Click the New button to select a signal and create a new search.

**Copy** - When the copy button is clicked, a new search is created identical to the current search. The new search is added to the Search Manager, renamed by adding a sequential number to the search name, automatically selected as the Global Search and is opened for editing. This is a very convenient feature if you want to add another search with similar criteria while retaining the original search or you need similar criteria for more than one signal.

**Delete** - Deletes the selected search.

#### 4.10.4 Auto Search Windows

Auto Searches expand the normal search to a linked list of positions in the captured data that meet the search criteria. Click on any line of the resulting list to scroll the matching data into view. Auto Searches also have the ability to halt the analyzer, determine which captures to preserve and which captures to discard based on the search result.

##### Main Auto Search Features

1. Automatically runs selected searches after each capture or [capture history](#) <sup>64</sup> load.
2. User settings allow for halting, saving or skip-saving the capture based on match counts.
3. Presents a list of matches and the count.
4. Clicking on a search match will bring the highlighted or focussed Waveform View to the time marked by the search match. All other views within the same link group as the waveform view will also update to the new time position.

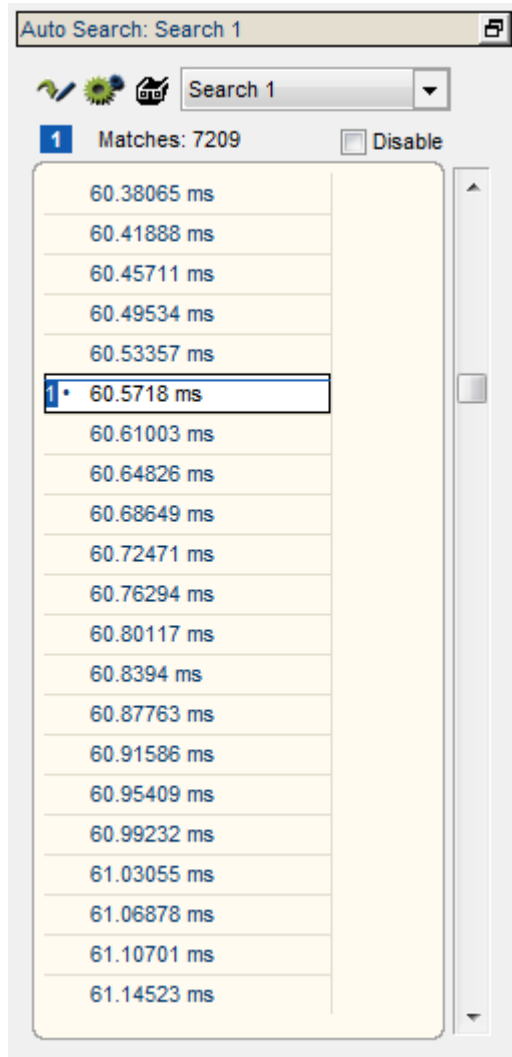

**Save, No Save and Halt Options** - Click the Menu Button to set the Auto Search Options.

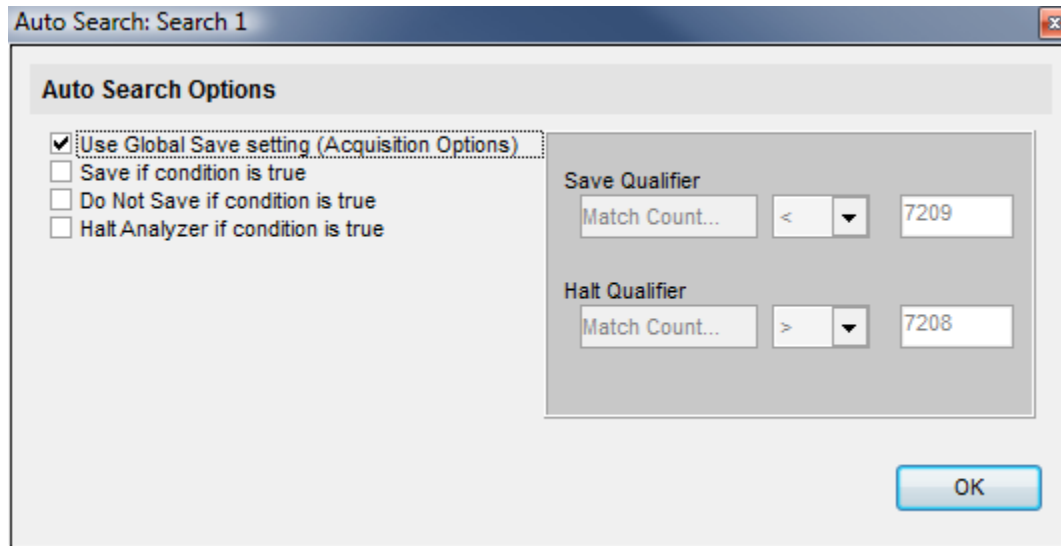

#### Use Global Save Settings

Select this option to let the default save settings determine when to save the capture. When selected, the Save Qualifier section is disabled. (see [Acquisition Options](#)<sup>[53]</sup>)

#### Save if Condition is True

Select this option to have the capture saved if the Save Qualifier equates to true. If the Global setting is already set to "Save" then this selection will have no effect. (see [Acquisition Options](#)<sup>[53]</sup>)

#### Do Not Save if condition is true

Select this option to mark the capture for "Discard" if the Save Qualifier equates to true. If the Global setting is already set to "Do Not Save" then this selection will have no effect. (see [Acquisition Options](#)<sup>[53]</sup>)

#### Halt Analyzer if Condition is True

Select this option to stop the analyzer from continuing to capture if the Halt Qualifier equates to true.

### 4.10.5 Search Types

Searches are defined in terms of Signals matching specific criteria. Depending on the search type, one or more signals are selected and a match pattern, match value or other conditions are defined for each. All Boolean, Bus and Analog signals use the Pattern Search type and all other signals (including those derived from Plugins), use the Sequential Search type.

Sequential searches allow a sequence of match conditions consisting of fields within frames among a sequence of frames. Each field match can have a specific value or a "don't care" (Any) value, and a specific skip count or a skip count of "Any". With the sequential search a very long sequence, consisting of multiple wildcards (any Field, any Frame, any Field Value) and specific frame or field skip counts and specific Fields and Field values, can be defined to locate the proverbial "needle" in a very long "hay stack". Sequential searches also have the option of placing the match marker at a specific point in the match sequence.

Pattern searches match a pattern across multiple channels and multiple signals at a signal point of time in the capture.

When ALL specified signals and conditions match the search criteria, the time of the match condition (or Match Point) will be centered in the window that has "focus". Any other windows that are a member of the same Link Group, will also center on the match point. (see: [Searching](#)<sup>[93]</sup>, [Link Groups](#)<sup>[90]</sup>)

Details of each search type below are explained in the following sections.

[Sequential Searches](#)<sup>[97]</sup>

[Pattern Searches](#)<sup>[102]</sup>

#### 4.10.5.1 Sequential Searches

The Sequential search type is used by all Plugins or Parsed (decoded) signal types. This includes all signals except the Boolean, Bus and Analog signal types (see: [Define Searches](#)<sup>[91]</sup>).

This search type has a group of search terms (or criteria) that is specific to the chosen signal type, and can perform a search sequence by adding additional terms. Terms can be added by using the Copy or More buttons.

By changing the Mode (Field or Frame) to Fields, you can target the search to sequentially match while ignoring frame boundaries. To look for a sequence of multiple frames, each having their own field sequence match, select the Frame mode. If frame information is not present in the data, the Mode will be limited to Field sequences.

## Field Mode

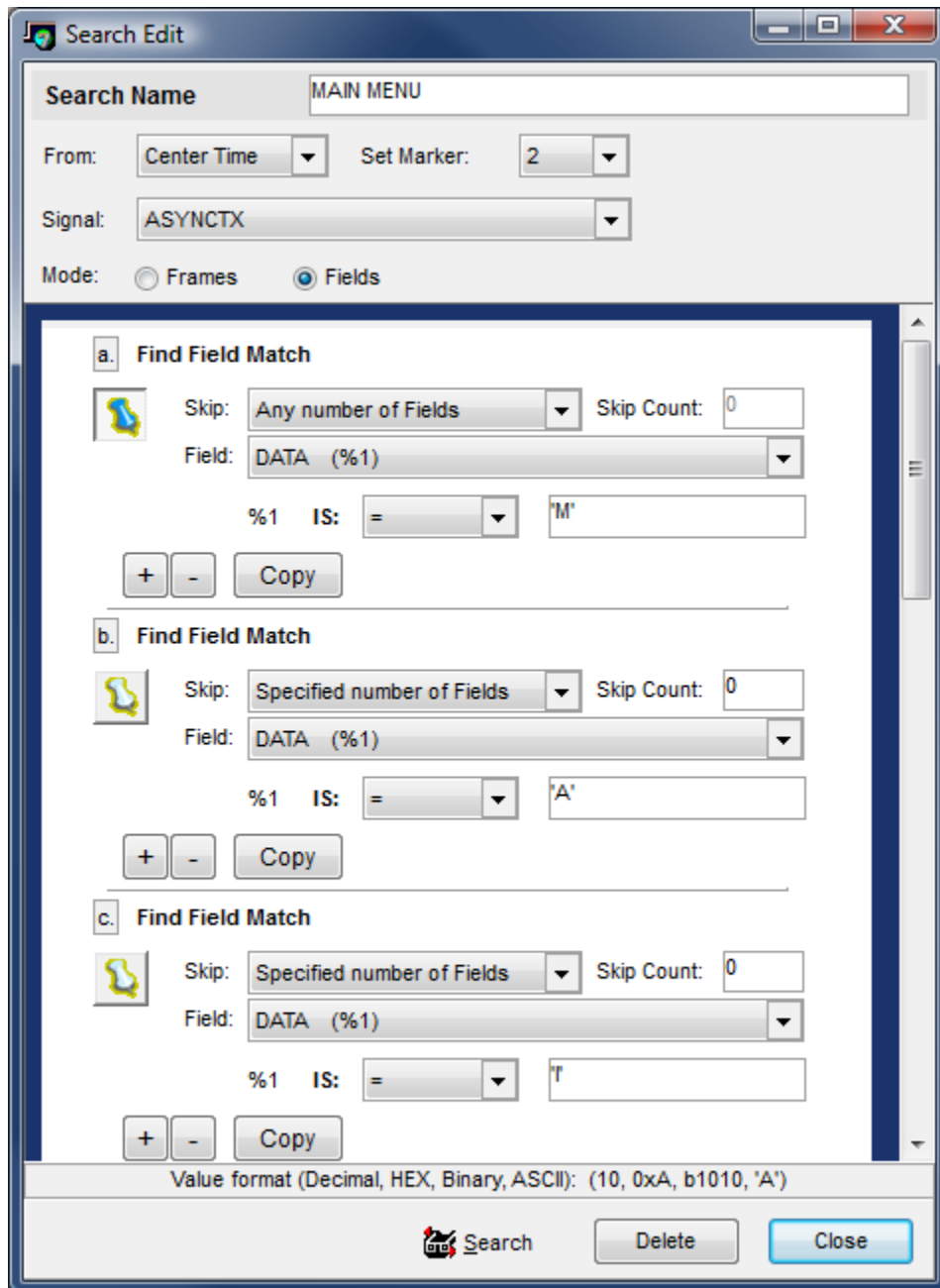

The number of Field terms is unlimited and each term is labeled using ASCII characters. In the image above, three field terms are visible (a., b., and c. ). Using term 'a.' as an example, each option is explained below.

**a. Find Field Match**

**Push Pin button** - This identifies which point in the sequence will be marked as the match time in the search results. When selected, the 'Push Pin' will appear blue, indicating the marker selected for the search will be placed at the beginning of this specific match term. When de-selected, it will appear white, meaning another term in the sequence has been selected for the marker position. If all terms have been de-selected, the first term in the sequence will be selected automatically for the marker position.

**Skip and Skip Count** - Skip options are "Any number of fields" or "Specified number of fields". When set to "Any number of Fields", the search will ignore the skip count and continue searching for the next field that matches the criteria. The search will continue to the end of the captured data if necessary before reporting a 'no match'. However, when set to "Specified number of Fields", the search will only ignore (and skip) the number of fields specified in the skip count editor before looking for the next match. If the next term after the skip count does not match, then the search reports a 'no match'. Setting the skip count to a value of "0" instructs the search to analyze the very next field in sequence (Do Not Skip).

**Field** - Some Signal types will have many field identifiers that can be used for targeted searching. The Field selection can be used to choose the specific field type to search. If the field to consider for the match is not the type specified, then the result is a 'no match', even if the value for the field matches the specified value. The field selection options for the built-in Async Signal type are shown below.

**Value to Match** - Depending on the specific field type, 1 or more values can be specified for the match. Some fields do not have any additional values, so the search is a 'match' if the specified field is found (i.e. Parity Error above). Other fields may have several values within the field. Each value is referenced in the value editors with a preceding "%". As shown above, the 'DATA' field has 1 value, identified by "%1". Below is an example of the editor for the DATA field.

The value to search for can be specified in Decimal, HEX, Binary or ASCII format as demonstrated below.

- Decimal - 77
- HEX - 0x4D
- Binary - b1001101
- ASCII - 'M'

An example of a Field with more than 1 value (from the SPI signal type):

a. Find Field Match

Skip: Any number of Fields Skip Count: 0

Field: MOSI-MISO (%1 : %2)

%1 IS: ANY

%2 IS: >= 0xDE

+ - Copy

**Buttons** - The three buttons on the bottom left of a field term are for deleting the current term (-), adding a new term below the current one (+) or creating and adding a duplicate of the current term (Copy).



Frame Mode

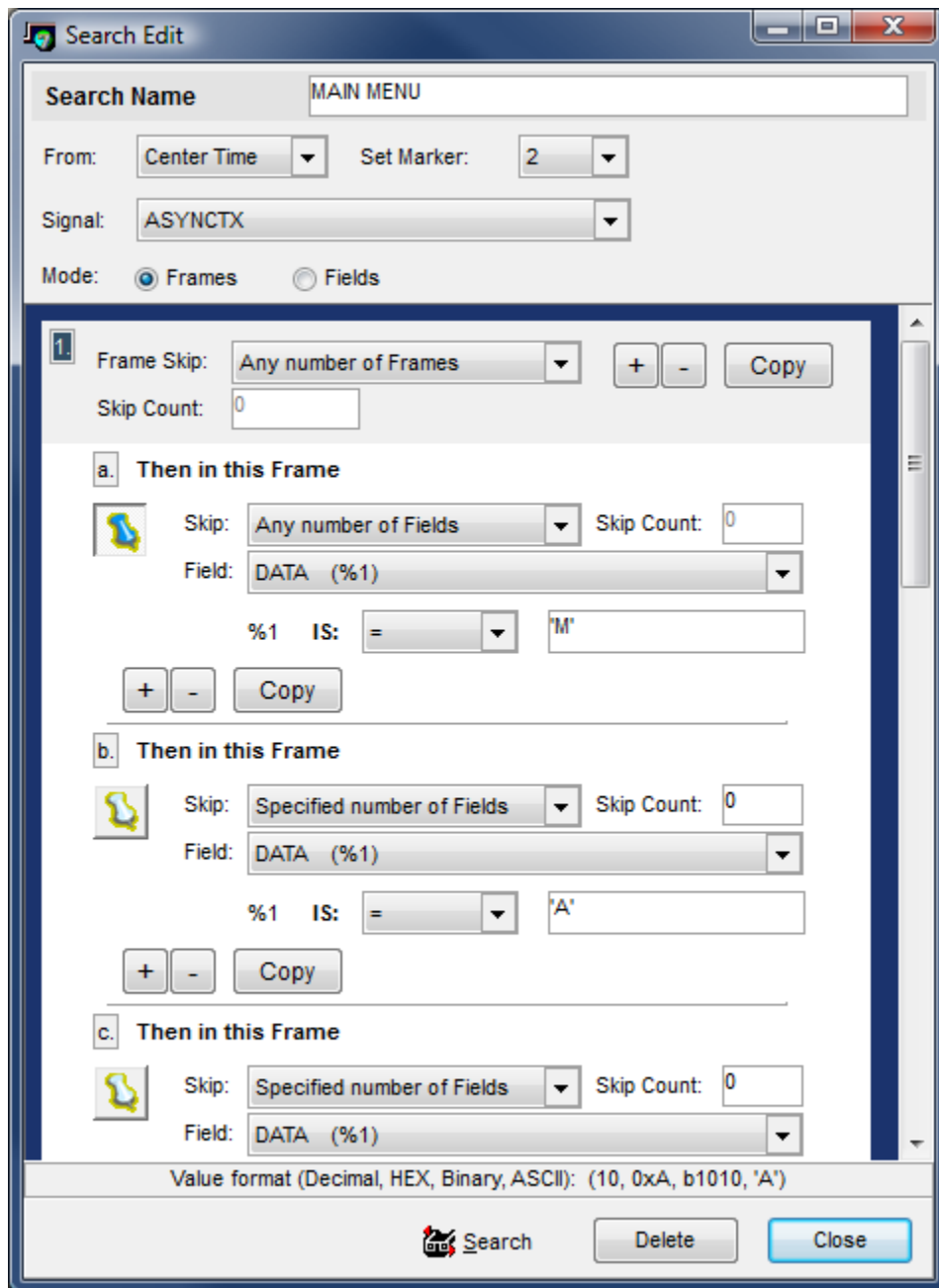

Frame mode uses the same logic as field mode but adds an additional layer of grouping if frame information is present in the data. The number of frame terms is not limited and each frame is labeled numerically, starting with "1".

**Skip and Skip Count** - The Skip and Skip Count parameters apply to Frames (a group of fields) instead of fields. The Field match sequence within each frame is limited to the fields bounded by framing data of the signal type. We do not limit the number of Field terms or skips within a frame. However, If you specify a sequence that involves a greater number of fields

than the number of fields available in the framed data, the search will fail.

**Buttons** - In frames, the Delete, Add and copy buttons are located at the upper right corner of the frame term and have the same functions as those described for fields, but apply to the frame. If you copy a frame, the new frame will be identical to the one copied, including all field terms and their individual settings.

#### 4.10.5.2 Pattern Searches

The Pattern search type is used for Boolean, Bus or Analog signal types (see: [Define Searches](#) <sup>[91]</sup>, [Boolean Signals](#) <sup>[11]</sup>, [Bus Signals](#) <sup>[12]</sup>, [Analog Signals](#) <sup>[16]</sup>).

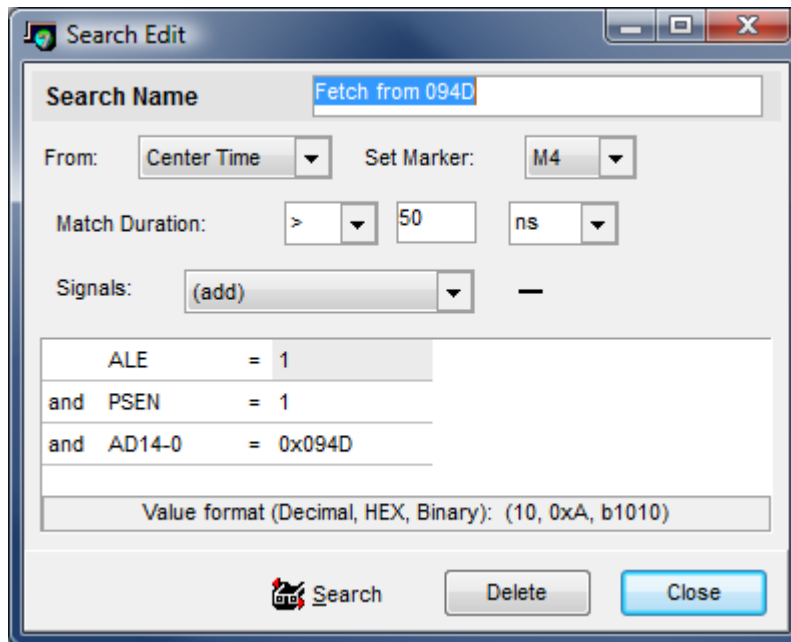

This search type can be used to find a value of one signal or a pattern of values in multiple signals, that lasts for a specified time period.

You can see in the "Fetch from 094D" search displayed above, that it will search for a pattern consisting of values from three signals (ALE, PSEN, AD14-0) that lasts for a duration of more than 50 nanoseconds. If this condition is found in the captured data, the specified marker will be set to the time when the match occurs. In the above example, this would be 50ns after the matching pattern begins.

**Match Duration:** Determines whether to skip all packets until a match is found, or to skip the number of packets specified in "Skip Count" and then see if the next packet is a match.

**Duration Units** The duration qualifiers can be in ns,us,ms or sec and can use REAL numbers (1.23 us).

**Signals:** Select a signal from this list to "add" them to the search. Signals added to the search are displayed below the signal selection box where the pattern to match can be edited.

**Match Pattern Format** The match patterns can be specified in decimal, hex or binary. To indicate a HEX specification, precede the number with '0x'. To indicate BINARY, precede the number with 'b'. Binary specifications allow '0','1' and 'X' (don't care) characters. HEX specifications allow HEX digits (0-1,A-F) or 'X' for a nibble of don't care bits. Decimal specifications must use only 0-9.

# Window Arrangement

**Part**

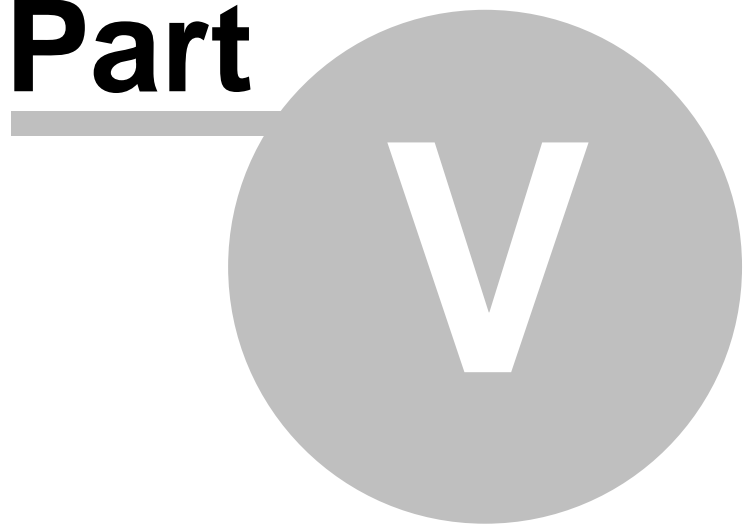

## 5 Window Arrangement

DigiView makes extensive use of Docking and Tabbing to permit very flexible window arrangements. All window settings, positions and sizes are saved along with the captured data anytime you save a file or exit the program. These settings are all restored when you start the software or load an existing '.DAT' file (see [Saving and Restoring](#)<sup>[129]</sup>).

The main application is called the Primary window.  
The windows created from the 'Windows' menu are called secondary windows.

[Docking Windows](#)<sup>[105]</sup>

[Tabbing Windows](#)<sup>[106]</sup>

### 5.1 Docking Windows

#### Dock Sites

The main application form has 6 docking sites; top, bottom, far top, far bottom, left and right. Any of the secondary windows can be 'docked' to one of these sites by dragging the window over the site. To prevent docking while dragging a window near a dock site, hold the Control key down while dragging.

#### Docking a Window

When dragging a window over a docking site, a gray rectangle appears to indicate that the dock site is willing to accept the window. Releasing the mouse button at this point docks the window to the main form at this spot.

Multiple windows can be docked into each of the dock sites in a variety of positions. As you drag additional windows over a given dock site, a different gray rectangle indicates where the window would split into the dock site. You can drag it near the top, far top, bottom, far bottom, left or right edges to control the placement.

If you drag the window inward a bit more, the rectangles change slightly to indicate a willingness to split the space occupied by an existing docked window, rather than the dock site itself.

Dragging the window further towards the center of a docked window will cause the rectangle to center in the window, which indicates the new window will "TAB" with the existing window (see: [Tabbing Windows](#)<sup>[106]</sup>). This flexibility allows you to dock the windows in virtually any configuration.

#### Floating a window

To 'undock' a window, simply drag it off of the dock site by its title bar, double-click its title bar or click on the down arrow in its upper right corner.

To 'untab' a window from a group of tabs, simply drag its tab away from the group and it will become an independent window again.

#### Over-riding Docking

If you wish to drag a window near a dock site but do not want it to actually dock, hold down the control key while dragging. This will disable the docking behavior, allowing you to drop the window without docking it.

(also see: [Tabbing Windows](#)<sup>[106]</sup>).

## 5.2 Tabbing Windows

### Tabbing windows

Secondary windows can be merged together by dragging one window over another. When you drag any secondary window over another secondary window, a centered rectangle line appears.

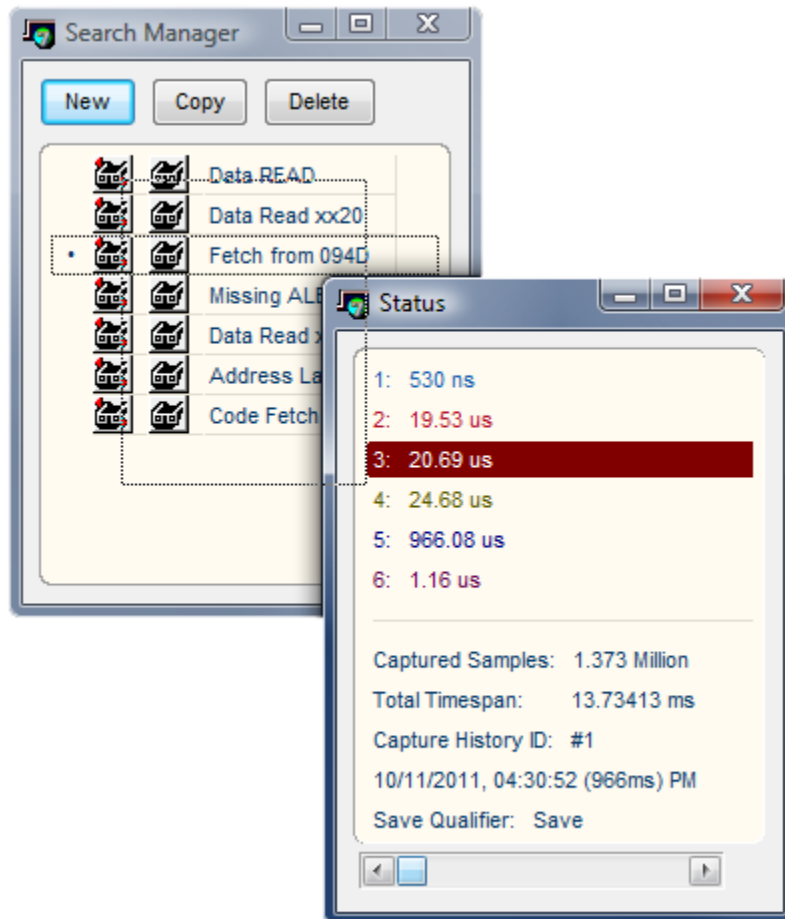

This indicates that dropping the window at this point will merge them together into a single window. Each original window appears on a TAB in the new window. Dropping additional windows onto the tabbed window creates additional tabs.

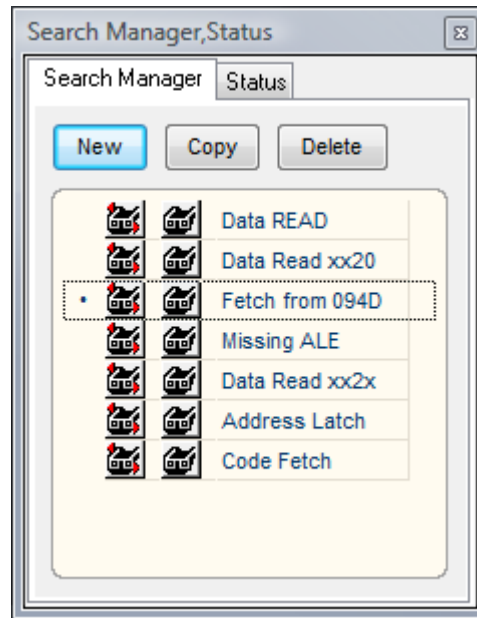

Tabbed windows can be docked just like any normal window. Also, a secondary window can be tabbed with a secondary window that has already been docked. Simply drag the window over the center of the docked window until you see the centered gray rectangle. This will TAB them together at the docked location rather than dock the new window next to the existing window.

#### Floating a tabbed window

You float a tabbed window just like a normal secondary window; simply drag it off of the dock site using its title bar, double-click its title bar or click on the down arrow in its upper right corner. This will float the entire tabbed window, keeping all of its tabs intact.

#### De-Tabbing a window

To remove a window from a tab, simple grab the tab and drag it or double-click on the tab. This extracts the window from the tabs and floats it. When only two windows are tabbed together and one of these is removed, the tabbed window will be disposed of and the remaining window will now occupy the position previously occupied by the tabbed window. If the tabbed window had been docked, then the remaining window is now docked in its place. See [Docking Windows](#)<sup>[105]</sup> for more information on docking.

#### Tab Window Options

After "Tabbing" windows together, several display options are available from a pop-up menu that is accessible by Right-Clicking on any of the Tabs. For details on these options, see [Tab Window Options](#)<sup>[107]</sup>.

(also see: [Docking Windows](#)<sup>[105]</sup>, [Tab Window Options](#)<sup>[107]</sup>).

### 5.2.1 Tab Window Options

After "Tabbing" windows together, several display options are available from a pop-up menu that is accessible by Right-Clicking on any of the Tabs. Available options depend on the selected Tab Orientation.

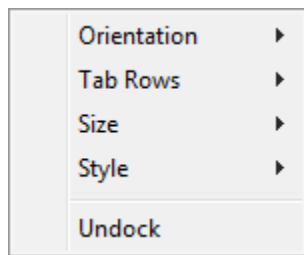

### Tab Orientation

Options are TOP, LEFT, BOTTOM, RIGHT. Choose one of these options to change the placement of the Tabs in a tabbed window.

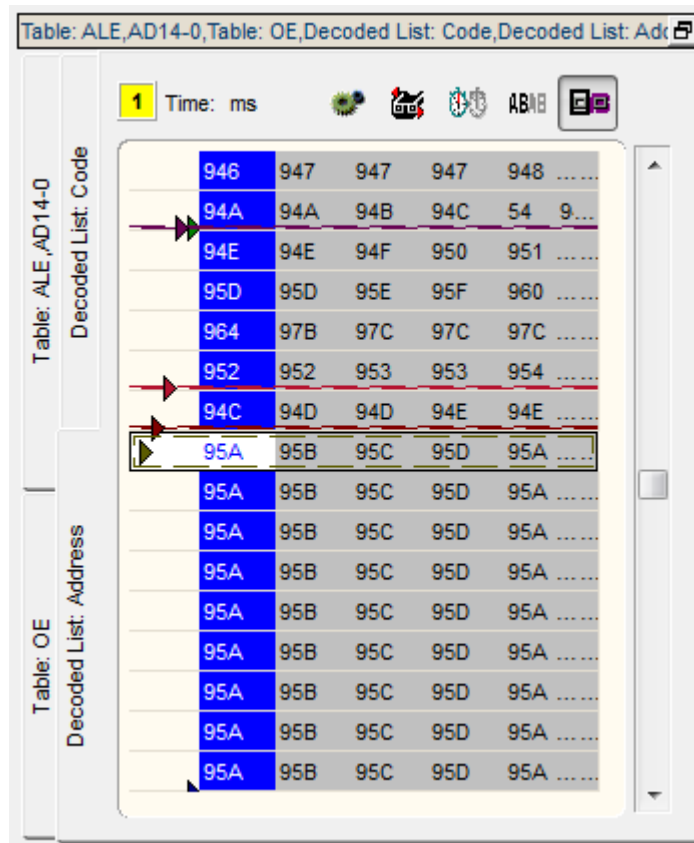



**Tab Rows**

Options are SINGLE, MULTIPLE. Choose multiple to have the tabs align in a single row with "scroll buttons" on the right. Choosing multiple will change the tabs to the default multiple row behavior and remove the "scroll buttons". Tab orientation must be set to Top or Bottom to select the Single option.

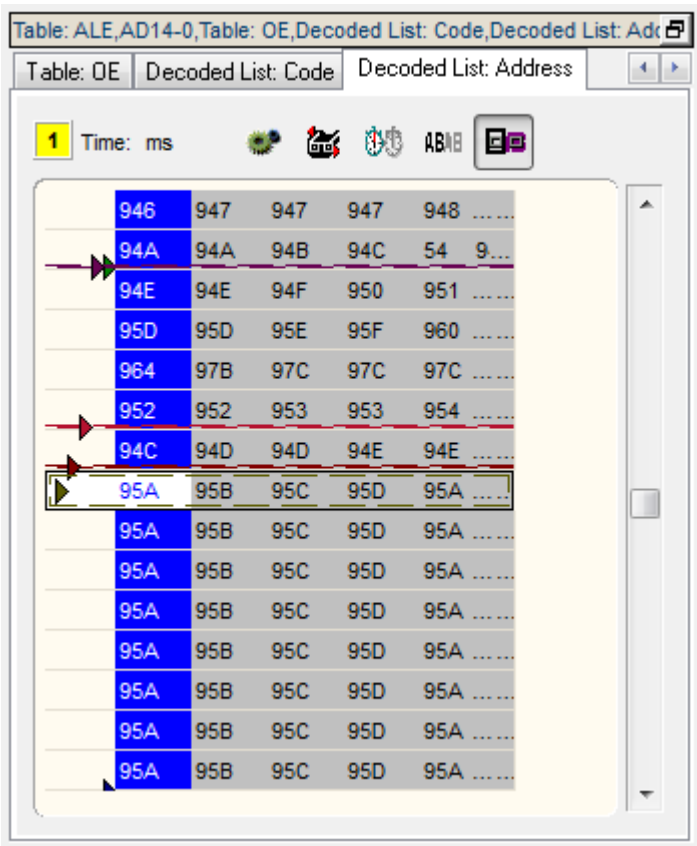

### Tab Size

Options are STRETCH TO FIT, NORMAL. Choose "stretch to fit" to have the tabs "fill" the available space when multiple rows are present. Select "normal" to size the tab to the length of its text.

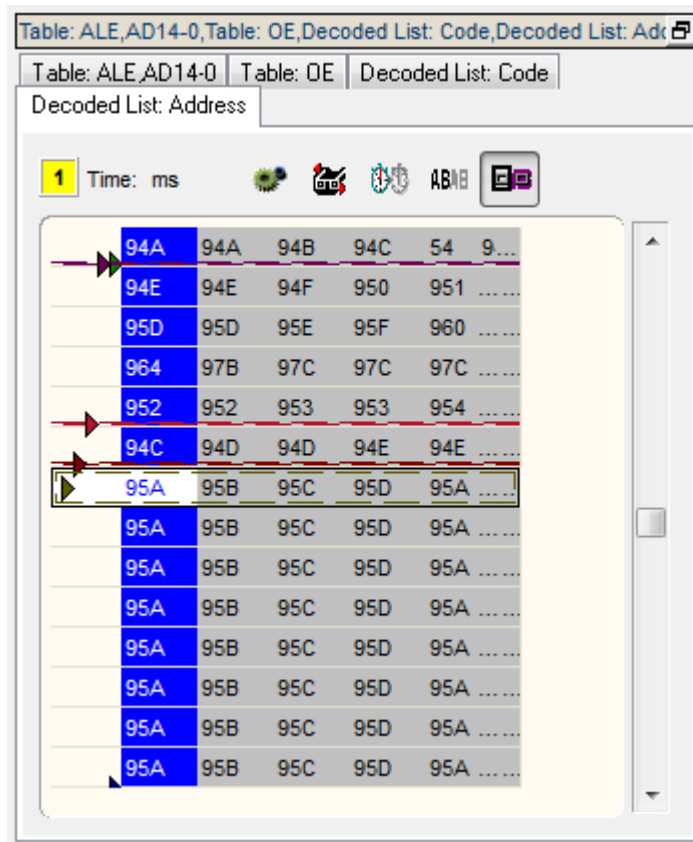

**Tab Style**

Options are TABS, BUTTONS, FLAT BUTTONS. Tab orientation must be set to "TOP" to select the option of Buttons or Flat Buttons.

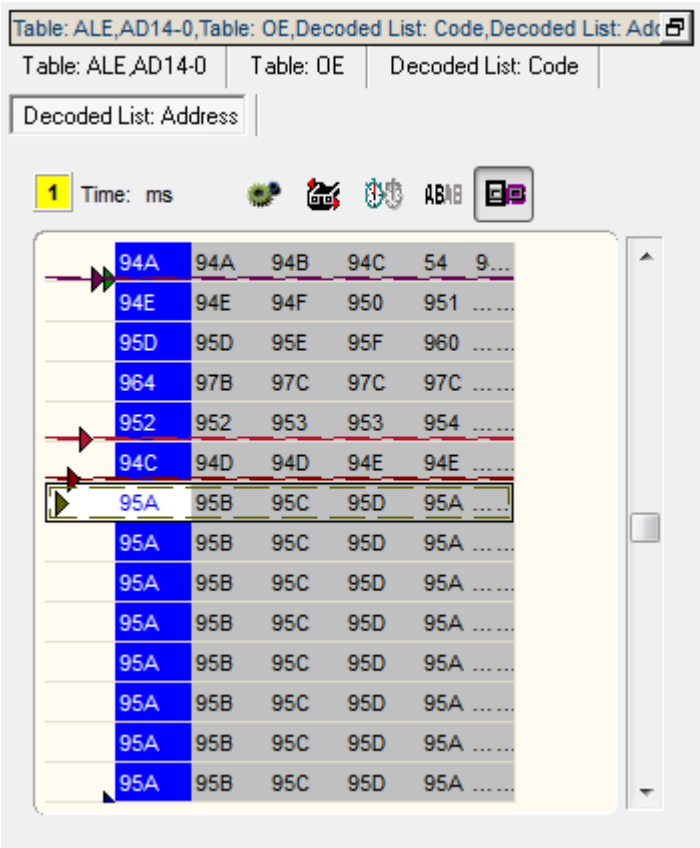

# Exporting

**Part**



**VI**

## 6 Exporting

The captured data can be exported to a file in ASCII format for further analysis or documenting purposes. DigiView provides three export methods to choose from with each method having a few unique features. These features are documented in the next three sections:

[Exporting All Signal Data \(Raw\)](#) <sup>[114]</sup>

[Exporting From List Windows](#) <sup>[116]</sup>

[Exporting From Table Windows](#) <sup>[117]</sup>

Properties common to all three export methods are discussed below.

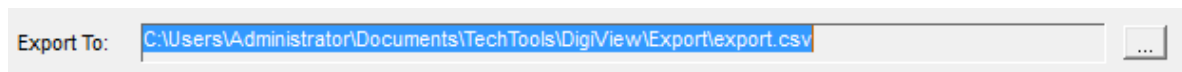

### Export To

At the top of each export dialog, the file name and path for the export file will be displayed. To change the name or location, choose the button to the right of the filename. You can choose any valid storage device for your system including a Network Drive, Floppy Disk, FLASH Memory, and etc.

<b>Time Range</b> From: <input type="text" value="Data Start"/> To: <input type="text" value="Data End"/> <input type="text" value="-5.56"/> <input type="text" value="Sec"/> <input type="text" value="21.7"/> <input type="text" value="Sec"/>		Estimated Free Disk Space: 59.42 GB Required Disk Space: <span style="background-color: red; color: white;">65.97 GB</span>
<b>Time Range</b> From: <input type="text" value="Marker 1"/> To: <input type="text" value="Data End"/> <input type="text" value="600"/> <input type="text" value="ms"/> <input type="text" value="21.7"/> <input type="text" value="Sec"/>		Estimated Free Disk Space: 59.42 GB Required Disk Space: <span style="background-color: yellow;">51.06 GB</span>

### Time Range

Select the Starting time and Ending time of the data to export. You can select from several predefined time points (i.e. Waveform View 1 Start, Trigger, Marker 3, etc) or select Custom to manually enter the time.

### Estimated Free Disk Space

The available space of the export destination is calculated and displayed here. The available space will be calculated whenever the destination changes. While the export is in progress, this will be updated to keep you informed of remaining space. If the available space becomes too small for the remaining portion of the export, then the export will automatically finish without exporting the rest of the data.

### Required Disk Space

The amount of disk space required to hold the exported data will be displayed here. Since all

storage devices require a minimum amount of space to hold a file, the minimum file size will be shown if the exported data is smaller. If the export size is very large, the background color of this display will turn to yellow. If the export size exceeds the available space on the storage device, the background color will turn to red and the export prevented from being performed. The export size will be calculated whenever any option or the destination changes.

**Progress indicator**

The lower left portion of the Export dialog will display the progress of the export. The progress display will indicate the number of bytes already exported, the percentage of the data already exported and the number of bytes per second being written to the storage device.

**Abort Button**

The export can be canceled at any time by selecting the Abort button. All data exported up to the point of cancellation will be available in the exported file.

**Close Button**

To exit the Export window, choose this button. If an export is in progress, the export will be canceled automatically.

**Export Button**

After selecting the desired export options, choose this button to begin the export. This button will be disabled while an export is in progress or the export size is being calculated.

## 6.1 Exporting All Signal Data

This export method can be selected from the File menu (File->Export->UnDecoded Capture) and provides a means of exporting the raw data of all defined signals. The available options let you chose which signals to export, time format, numerical format, field separator, inclusion of line numbers, inclusion of a timestamp and whether to use compression. (see: [Exporting](#)<sup>[113]</sup>)

The Exported Data Example area will be updated automatically to reflect any changes in export options.

The screenshot shows a software interface for exporting data. It is divided into two main sections: 'Format Options' and 'Signal Selection'.

**Format Options:**

- Timestamp:** Radio buttons for 'Absolute' (selected) and 'Delta'.
- Numerical Format:** Radio buttons for 'Hex' (selected), 'Dec', and 'Bin'.
- Field Separator:** Radio buttons for 'Comma' (selected) and '='.
- Checkboxes for 'Include Line Numbers' and 'Include Time Stamp', both of which are checked.

**Signal Selection:**

- Checkboxes for 'ALE', 'PSEN', 'OE', 'AD14-0', 'Code', and 'Address', all of which are checked.
- A 'Data Compression' section with radio buttons for 'On' (selected) and 'Off'.
- Buttons for 'Clear All' and 'Select All'.

**Exported Data Example:**

```
Line#,Time,ALE,PSEN,OE,AD14-0,Code,Address
0,-6965950,0,0,1,009D9,000D9,009D9
1,-6965700,1,1,1,009D9,001D9,089D9
2,-6965590,1,1,1,00990,00190,08990
3,-6965510,0,1,1,00990,00190,00990
4,-6965410,0,0,1,00990,00090,00990
```

### Timestamp

If the "Include Time Stamp" option is selected, the time field will be formatted as the absolute time or (if set to Delta) as the time since the previous sample (or the last known sample after the starting time). If the "Data Compression" option is set to OFF and this option is set to Delta, then the time field will show the sample rate.

### Numerical Format

This option determines the formatting for each signal that uses more than one channel (Boolean signals will always be formatted as a '1' or '0'). This option will display the format setting of a signal when a signal is selected. To change the format for a signal, first select the signal in the Signal Selection area. If changes are allowed for the selected signal, then the format options will "enable". Select the desired option.

### Field Separator

Choose the character for separating each item on a line of exported data.

### Include Line Numbers

Select this option to include a consecutive line number at the beginning of each line.

### Include Time Stamp

Select this option to include the time of each exported sample.

### Signal Selection

Check each signal to include in the export. The order of export is determined by the order in which each signal is checked. To have the export order match the listed order, use the Clear All button to clear all selections, then use the Select All button to select all the signals in the order

shown. To move a signal to the end of the export line, uncheck and then recheck the signal.

When a signal is highlighted with the mouse, its export format setting will be shown in the Numerical Format option. This option can be changed by selecting the desired format (excluding Boolean signals).

### Data Compression

Setting this option to ON will greatly reduce the size of the export file. With compression on, the redundant or "dead" periods of data will be excluded and only changes in the data will be exported. If this option is set to OFF, then no data will be eliminated and all samples at the maximum resolution will be exported. This could lead to very long exports with sizes up in the Terabyte range.

### Clear All Button

Use this button to "uncheck" all signals in the Signal Selection Area. Unchecked signals will be excluded from the export.

### Select All Button

Use this button to "check" all signals in the Signal Selection Area. All checked signals will be included in the export.

### Exported Data Example

This area provides an instant "preview" of the data to export and is updated when any option or signal selection is changed.

## 6.2 Exporting from List Windows

This export method can be selected from the File menu (File->Export->Table/List) or directly from a List Window's menu. List Exports export the decoded data of higher level signals (such as I2C), and will have a slightly different set of options that are specific to each signal type. (see: [Exporting](#)<sup>[113]</sup>, [Signal Types](#)<sup>[7]</sup>, [List View Windows](#)<sup>[87]</sup>)

The Exported Data Example area will be updated automatically to reflect any changes in export options.

Radix

HEX     Binary     ASCII

Decimal     Octal

Field Separator

Comma (,)     Equal Sign (=)

Field Mode (1 per Line)

Include Line Numbers

Include Time Stamp

Exported Data Example:

```
1,-29741709610,S,8,W,4,P
2,-29741628705,S,9,W,4,P
3,-29741548945,S,9,R,21,BA,CC,0,0,0,0,71,6B,2,F5,A3,0,0,0,1,N,P
4,-29631693720,S,8,W,4,P
5,-29631614145,S,9,W,4,P
6,-29631534410,S,9,R,21,BA,CC,0,0,0,0,69,27,2,F4,83,0,0,0,1,N,P
```



**Numerical Format (Radix)**

This option determines the formatting for each signal that uses more than one channel (Boolean signals will always be formatted as a '1' or '0'). This option will display the format setting of the signal in the list view being exported. To change the format for exporting, select the desired option.

**Field Separator**

Chose the character for separating each item on a line of exported data.

**Field Mode**

Select this option to force each field to a new line when framing data is present. Uncheck this option to output a frame of fields per line.

**Include Line Numbers**

Select this option to include the line number at the beginning of each line.

**Include Time Stamp**

Select this option to include the time of each exported sample.

**Exported Data Example**

This area provides an instant "preview" of the data to export and is updated when any option or signal format is changed.

## 6.3 Exporting from Table Windows

This export method can be selected from the File menu (File->Export->Table/List) or directly from a Table Window's menu. Table Exports provide all the same options as the "Export All" function, but will automatically include all columns of the table. This means you will not have to select which signals to export, plus all channels of any signals that are "expanded" will also be included in the export. This is the only export method that will export expanded channels. (see: [Exporting](#)<sup>[113]</sup>, [Export All](#)<sup>[114]</sup>, [Table Windows](#)<sup>[84]</sup>)

Tables display and export signals in their "raw" data format. If you need to export the decoded data of higher level signals (such as I2C), then the List Export should be used instead. (see: [List Export](#)<sup>[116]</sup>, [I2C Signals](#)<sup>[17]</sup>)

The Exported Data Example area will be updated automatically to reflect any changes in export options.

The screenshot shows the 'Export' dialog box in DigiView. It is divided into two main sections: 'Format Options' and 'Signal Selection'.

**Format Options:**

- Timestamp:** Radio buttons for 'Absolute' (selected) and 'Delta'.
- Numerical Format:** Radio buttons for 'Hex' (selected), 'Dec', and 'Bin'.
- Field Separator:** Radio buttons for 'Comma' (selected) and '='.
- Include Line Numbers
- Include Time Stamp

**Signal Selection:**

- Checkboxes for signals: ALE, AD14-0, -AD14-0:0, -AD14-0:1, -AD14-0:2, -AD14-0:3, -AD14-0:4, -AD14-0:5, -AD14-0:6, -AD14-0:7, -AD14-0:8, -AD14-0:9, -AD14-0:10, -AD14-0:11, -AD14-0:12, -AD14-0:13, -AD14-0:14. All are checked.
- Data Compression:** Radio buttons for 'On' (selected) and 'Off'.

**Exported Data Example:**

```
Line#,Time,ALE,AD14-0,AD14-0:0,AD14-0:1,AD14-0:2,AD14-0:3,AD14-0:4,AD14-0:5,AD14-0:6,AD14-0:7,AD14-0:8,AD14-0:9,AD14-0:10,AD14-0:11,AD14-0:12,AD14-0:13,AD14-0:14
0,-6965950,0,09D9,1,0,0,1,1,0,1,1,1,0,0,1,0,0,0
1,-6965700,1,09D9,1,0,0,1,1,0,1,1,1,0,0,1,0,0,0
2,-6965590,1,0990,0,0,0,0,1,0,0,1,1,0,0,1,0,0,0
3,-6965510,0,0990,0,0,0,0,1,0,0,1,1,0,0,1,0,0,0
4,-6965400,0,09D9,1,0,0,1,1,0,1,1,1,0,0,1,0,0,0
```

### Timestamp

If the "Include Time Stamp" option is selected, the time field will be formatted as the absolute time or (if set to Delta) as the time since the previous sample (or the last known sample after the starting time). If the "Data Compression" option is set to OFF and this option is set to Delta, then the time field will show the sample rate.

### Numerical Format

This option determines the formatting for each signal that uses more than one channel (Boolean signals will always be formatted as a '1' or '0'). This option will display the format setting of a signal when a signal is selected. To change the format for a signal, first select the signal in the Signal Selection area. If changes are allowed for the selected signal, then the format options will "enable". Select the desired option.

### Field Separator

Chose the character for separating each item on a line of exported data.

### Include Line Numbers

Select this option to include a consecutive line number at the beginning of each line.

### Include Time Stamp

Select this option to include the time of each exported sample.

### Signal Selection

All Signals in the Table are automatically displayed in this area and "checked" for export. To exclude a signal from the export, cancel the export, remove the signal from the Table, then select export again. Optionally you could use the Export All function if you do not need to export

---

the channels of "Expanded" signals. (see: [Export All](#)<sup>[114]</sup>)

When a signal is highlighted with the mouse, its export format setting will be shown in the Numerical Format option. This option can be changed by selecting the desired format (excluding Boolean signals).

**Data Compression**

Setting this option to ON will greatly reduce the size of the export file. With compression on, the redundant or "dead" periods of data will be excluded and only changes in the data will be exported. If this option is set to OFF, then no data will be eliminated and all samples at the maximum resolution will be exported. This could lead to very long exports with sizes up in the Terabyte range.

**Exported Data Example**

This area provides an instant "preview" of the data to export and is updated when any option or signal format is changed.

# Printing

**Part**

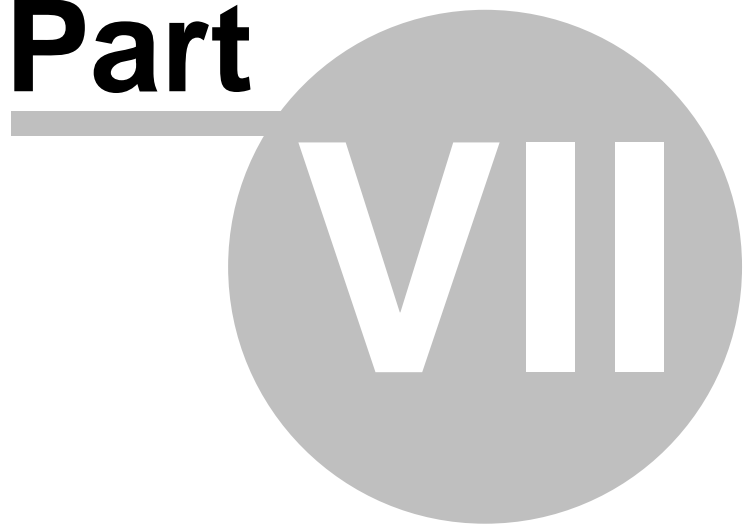

## 7 Printing

While analyzing the data, you may want to save a specific view to a graphic file or send it to a printer. Both of these functions can be done from DigiView's Print window. To open the Print window, select a Table, List, Waveform view or the main view from DigiView's FILE menu. The selected view will be presented in the Print window with the options set to JPEG by default. The view to print can also be selected directly from a view's popup menu.

Details of the Print Window's options are described in the next two sections.

[Printing Options](#) <sup>[122]</sup>

[JPEG Options](#) <sup>[125]</sup>

## 7.1 Printing Options

To send the view's image to a printer, select Printer as the Output Type. After selecting this output type, the options in the Print Window will change for printing.

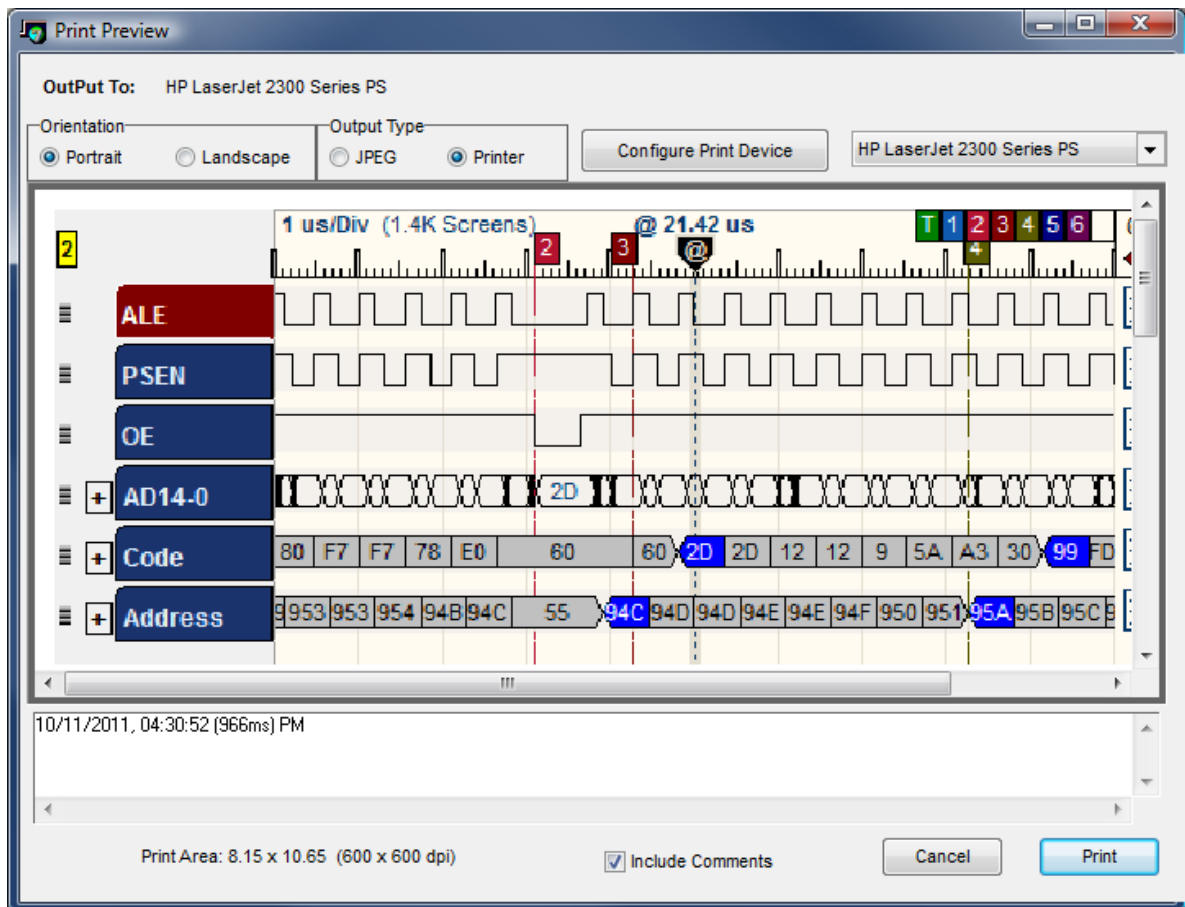

### OutPut To

The currently selected printer name or print driver name will be displayed here.

### Orientation

Select the orientation. This is the same setting that can be accessed from the Configure Print Device options.

### Configure Print Device

Use this button to access all options of all available print devices.

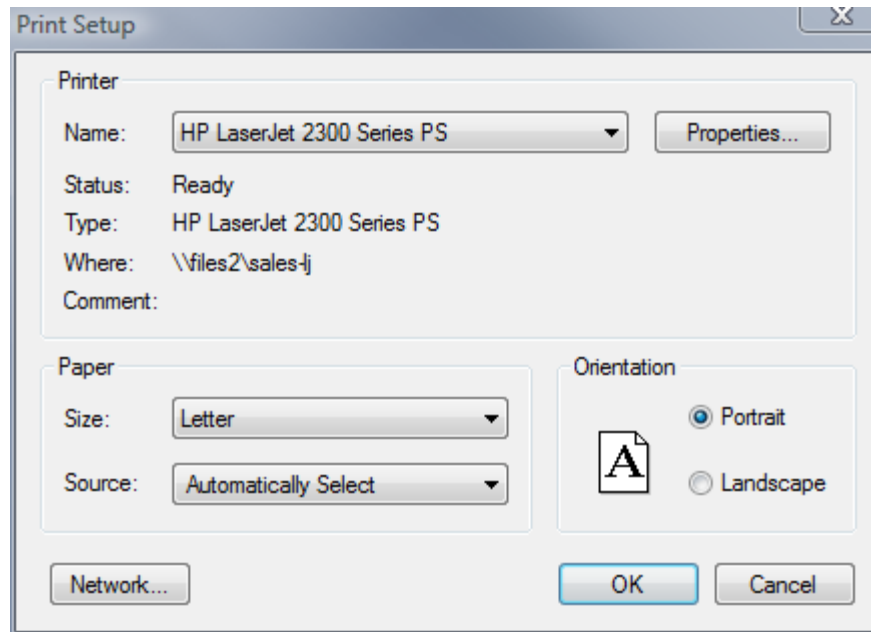

Select a different printer by using the selection box in this window. Available printers can also be selected in the selection box beside the Configure Print Device button if you do not need to access the printers detailed properties. Select the Properties button to access detailed options of the displayed printer.

### Include Comments

Select this option to add comments to the Bottom of the image to be printed. When the Print Window is opened, the capture data and time are automatically added to the comment section. If you do not want to include the capture information, it can be deleted.

The comment box below the image to print will increase in size as you type comments. If the comment needs more room, the size of the image will decrease. The preview in the upper

portion of the window will automatically update as you change options or type comments.

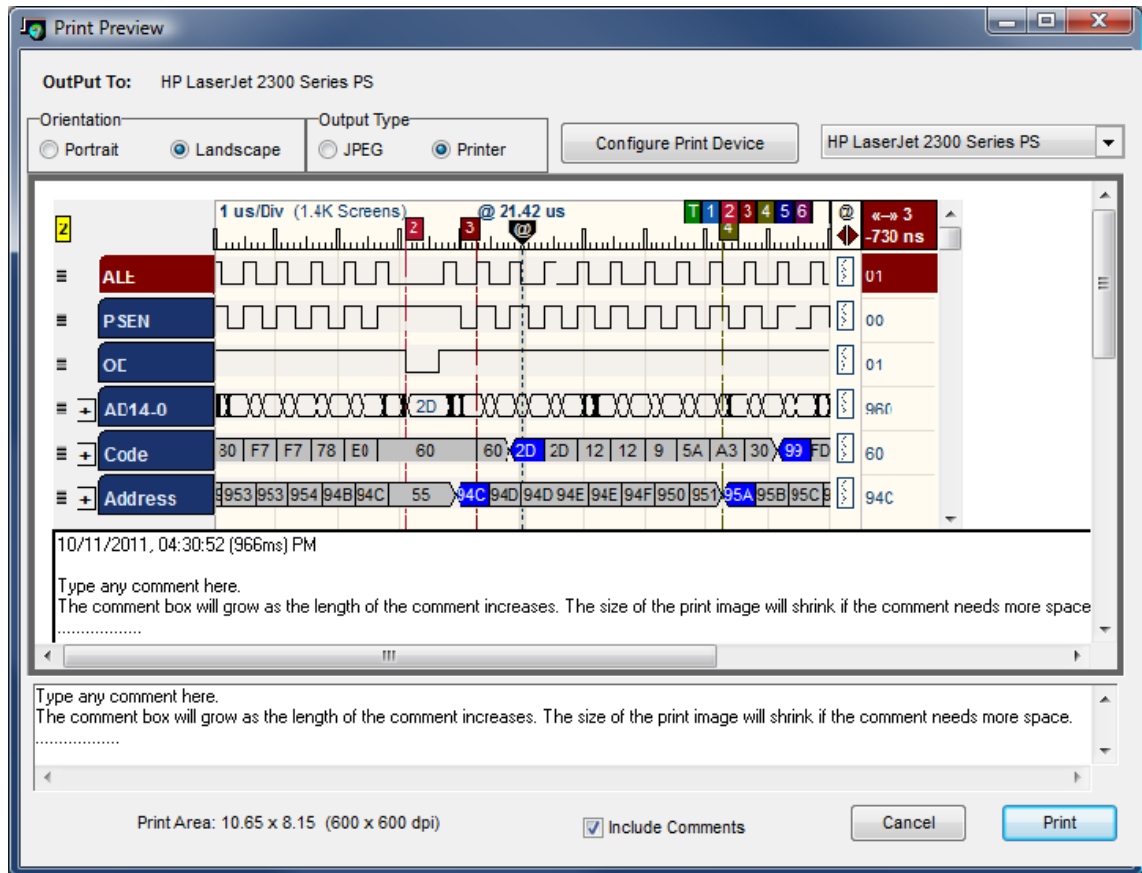

### Cancel Button

Use this button to close the print window without printing.

### Print

Use this button to send the image to the printer.



## 7.2 JPEG Options

To save the View's image as a JPEG file, select JPEG as the Output Type. After selecting this output type, the options in the Print Window will change for JPEG images.

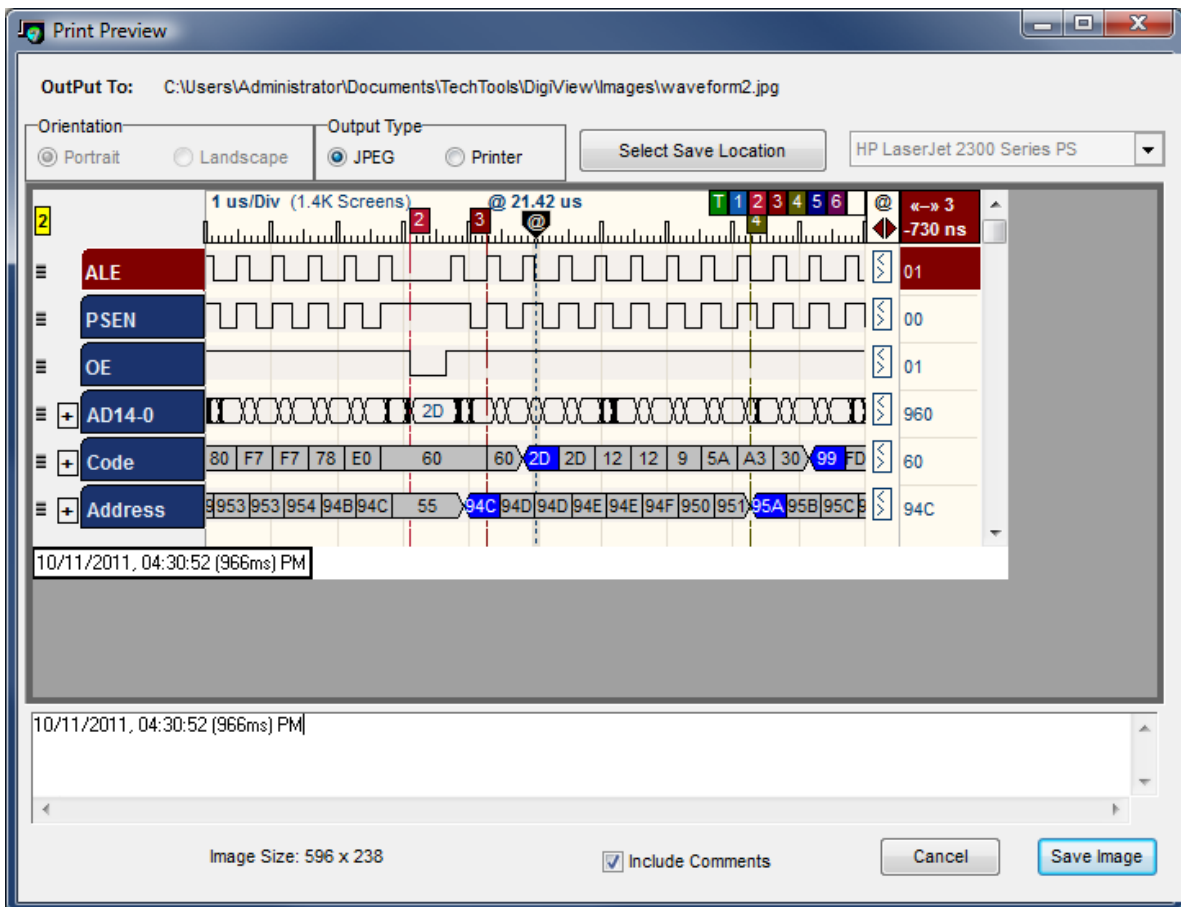

### OutPut To

The currently selected image file name and path will be displayed here. Use the Select Save Location button to change the name or path and preview images already saved.

### Select Save Location

Use this button to change the destination and save the image or preview images already saved.

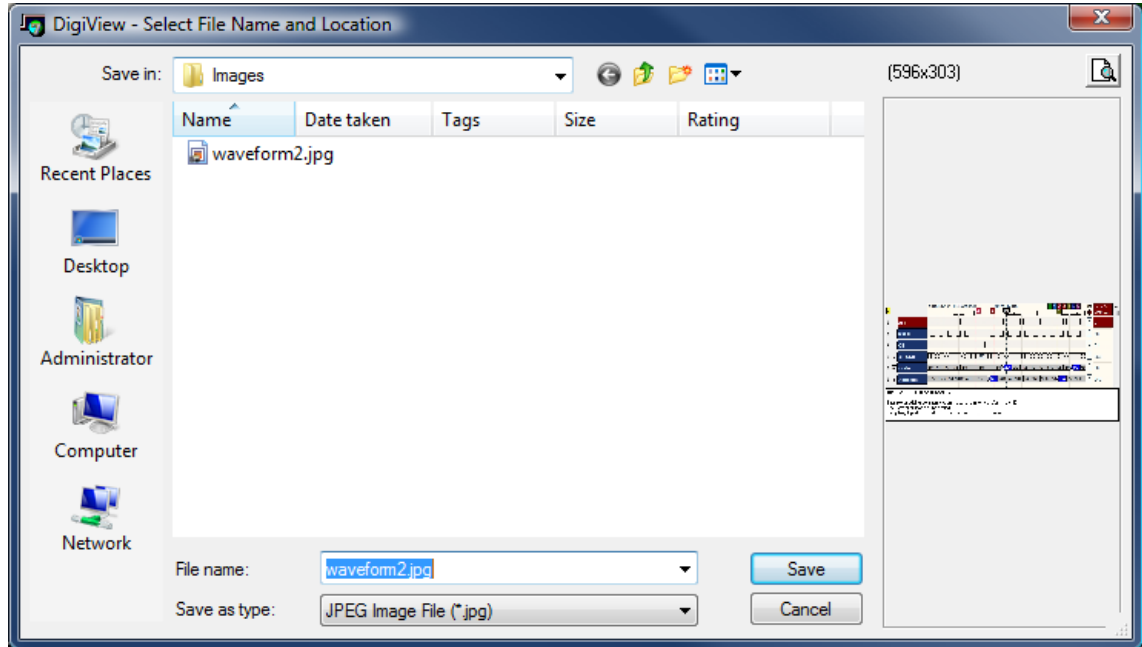

To preview a saved image, select an image from the list, then use the button in the top right corner of the window.

To exit this window without saving the image, choose the Cancel button.

### Include Comments

Select this option to add comments to the Bottom of the image to save. When the Print Window is opened, the capture data and time are automatically added to the comment section. If you do not want to include the capture information, it can be deleted.

The comment box will increase in size as you type comments. Since the comment box is actually part of the image to save, the size of the image will increase as the comment needs more room. The preview in the upper portion of the window will automatically update as you change options

or type comments.

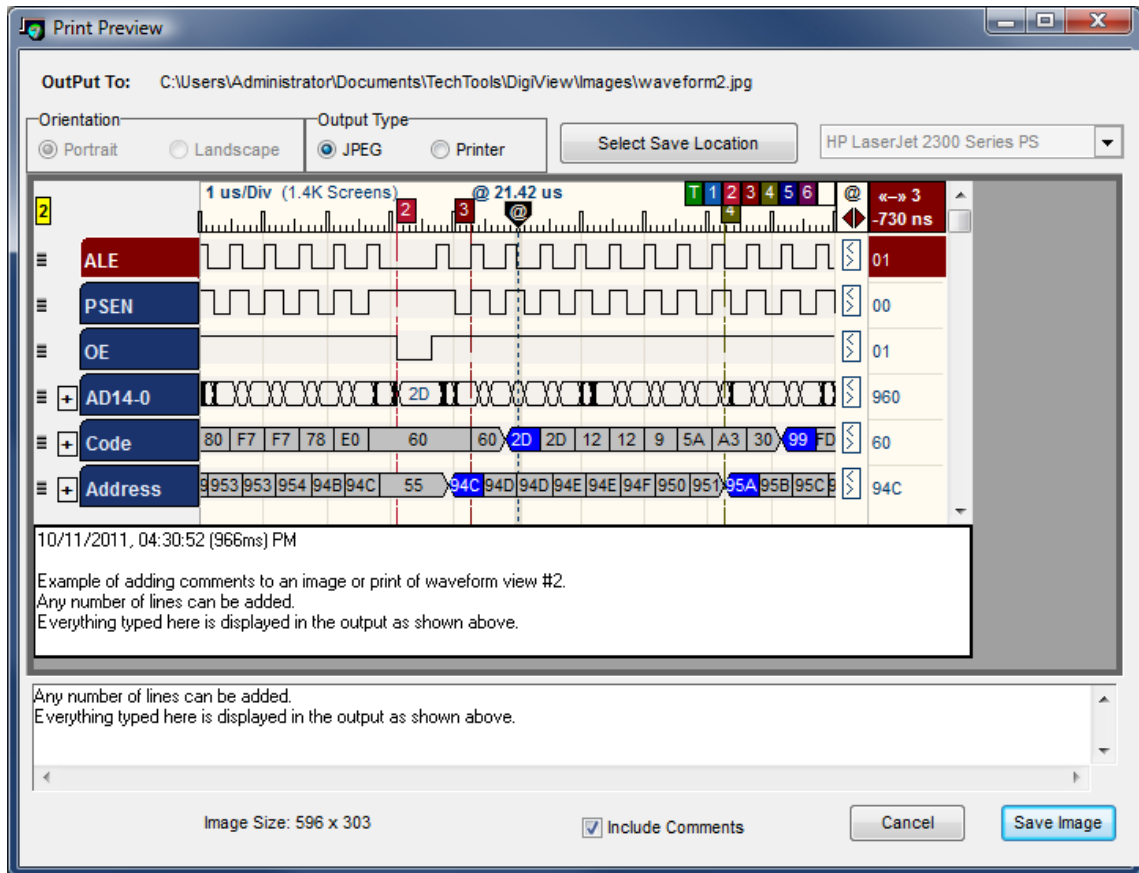

**Cancel Button**

Use this button to close the print window without saving the image or if the image was already saved when selecting the destination.

**Save Image**

Use this button to save the image to the selected destination.

# Creating, Saving and Restoring Project Files

**Part**

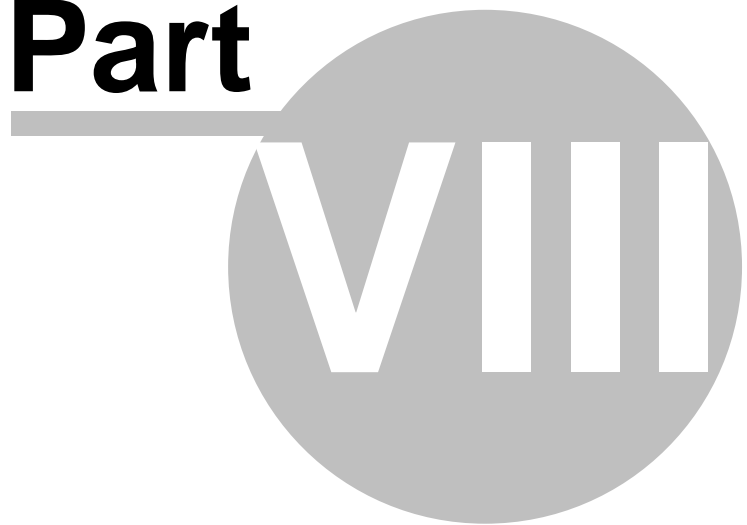

## 8 Creating, Saving and Restoring Project Files

### Save Project File

The Save Project function is under the FILE menu. The current state (Zoom, time, marker locations, waveforms associations, etc.), all windows, signal definitions, search definitions, trigger definitions, and the data buffer of the current capture are saved to the file you select.

**The data is always stored in compressed format, so the size of the project file will vary from a few KBytes up to just over 4 MBytes.**

### Save As New Project

The Save As New Project function is located on the FILE menu. It performs the same function as the normal "Save Project" option, but will prompt you for a new name and ask permission to copy the capture history for the new project. The entire capture history for the current project will automatically be copied for the new project if you select yes when prompted. The "Copy History" prompt also displays the amount of disk space being used by the history files and will copy as many files as free space allows, leaving a safety margin. The most recent captures are copied first in case you do not have enough space available for the entire history to be copied to the new location.

### Open...

The Open (Restore) function is under the File menu (File->Open). This will load a previously saved project file and verify its capture history.

### Auto Save/Restore

The "Auto Save" and "Restore last File" options are found in the [Environment settings](#) (found under the CONFIG menu). When both of these options are enabled, DigiView auto-saves the current data, settings and state of the project when you exit the program (or have requested a different project to be loaded) and auto-loads the last opened project when you start the program. This allows you to pick-up where you left-off the next time you start the software without having to save/restore. You can still save the project manually anytime you need by using the "Save Project As" selection on the File menu or clicking the "Save" button.

### New Project

To start completely fresh and eliminate all defined signals, searches, data, triggers and windows, select the New Project option from the File menu.

When creating a new project file, you must select the proper analyzer model and optionally the preferred sampling mode. For this reason, the software will provide a selection window with information regarding any detected hardware as shown below. Simply select the Model and the Sampling Mode, then click on the "OK" button to create a new file. If you do not want to create a new project, then select cancel to continue with the currently loaded project.

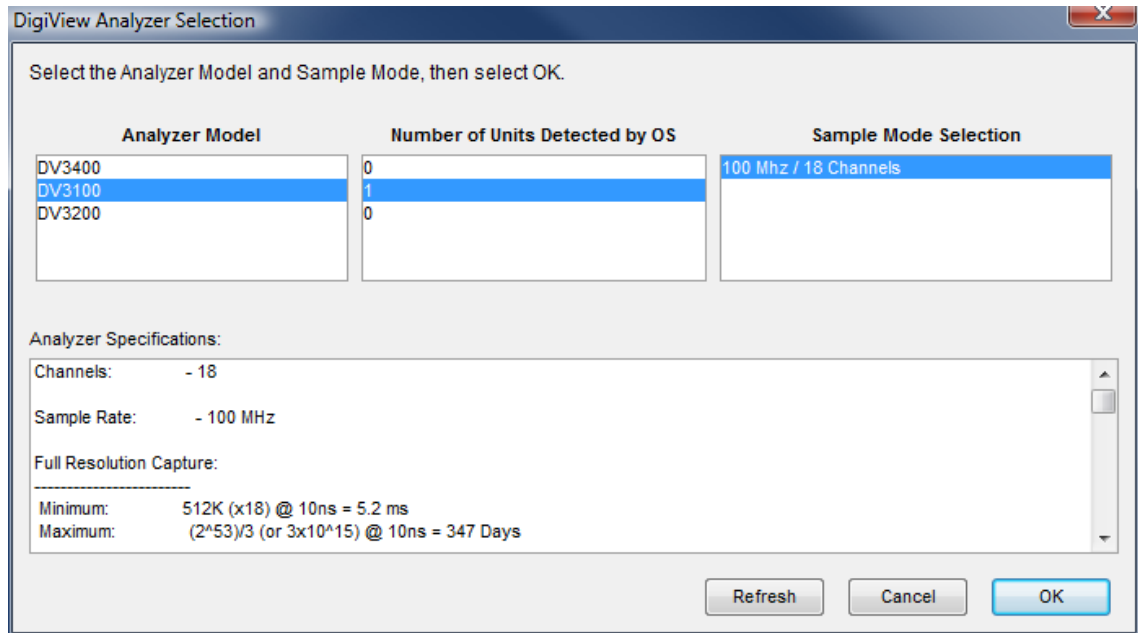

## Convert Project

If you want to use the same project configuration but convert it to be compatible with a different model of analyzer, select the "Convert Project" option from the File menu. However, be aware that Conversion will delete the current project's Capture History. If you have a capture history that you want to preserve, the project should be saved with a new name before converting.

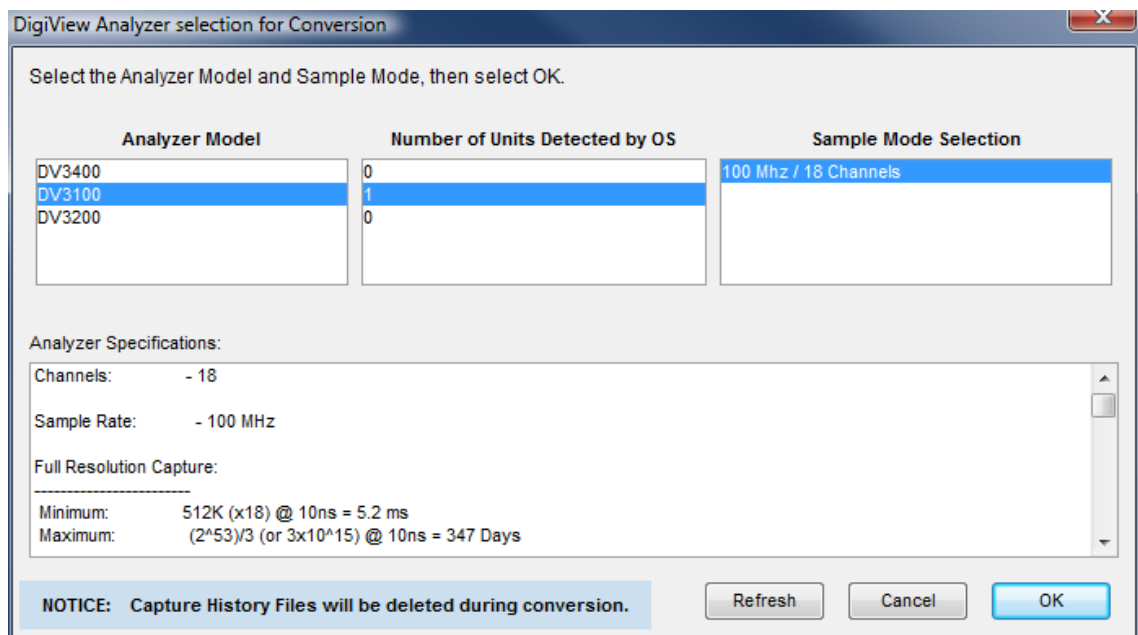

# Appendices

**Part**

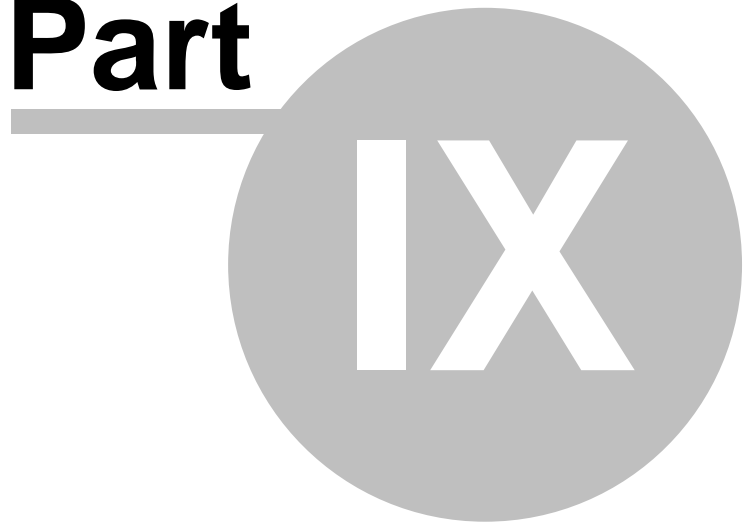

## 9 Appendices

[DigiView Compression](#) <sup>[132]</sup>  
[Hardware Specifications](#) <sup>[135]</sup>

### 9.1 DigiView Compression

**There is no need to understand DigiView's compression to use it. This is just here for the curious (or skeptical).**

We want two conflicting features in a logic analyzer; high sample RATES (high resolution) and high sample COUNTs (a lot of data/time). We usually reduce sampling RATES to capture more data because sample COUNTs (data buffer depth) is fixed. To combat this trade-off, the sample buffer is made as deep as possible. However, this approach is linear and does not scale well. Doubling the buffer doubles either TIME or sample RESOLUTION. It can take gigabytes of memory to achieve both if your data transitions are fairly sparse (microsecond or more gaps).

Ideally, we would like to have high sample RATES AND high sample COUNTs to capture a long time-span with high resolution.

DigiView achieves this, like other logic analyzers, by using a deep data buffer. However, DigiView also attacks this problem from another, even more effective angle. DigiView uses one or more **real-time, hardware based compression** techniques to compact the captured data. This has a much greater impact than increasing the buffer depth.

Most data you are likely to monitor lends itself well to our compression technique(s). Compression ratios of 100:1 are common. With sparse data, compression ratios of over 200,000:1 are achievable. Since the degree of compression depends on the amount of activity, you will achieve maximum compression if you only define signals of interest. DigiView analyzers will always sample at the maximum rate for the mode selected. Due to automatic real-time compression techniques, you receive the benefits that down-sampling would achieve (longer captures) without the loss of data resolution.

The data captured in logic analyzer applications is often stable for multiple sample periods (particularly at higher sample rates). This, coupled with fast sample times and a very long run-length limit, makes our compression very applicable in real-world applications.

To illustrate the effect of DigiView's compression and also present it in a manner that is more relevant to real-world usage, we have calculated several typical performance benchmarks for each DigiView Model and sampling mode. You may actually see better performance ratings than the conservative estimations below.

#### DV3100

Channels: - 18  
Sample Rate: - 100 MHz



Full Resolution Capture:

```

-----
Minimum:          512K (x18) @ 10ns = 5.2 ms
Maximum:          (2^53)/3 (or 3x10^15) @ 10ns = 347 Days

Serial (assumes > .01 Baud, < 172 sec. between bits/bytes)
  RS232:          > 31,000 characters
  SYNC:           > 8,000 characters

Serial (assumes > 1.5K Baud, < 655 us. between bits/bytes)
  RS232:          > 47,000 characters
  SYNC:           > 12,000 characters
  I2C:            > 10,000 characters

8051 cycles:     > 40,000 code fetches
1MHz clock:      > 131,000 cycles,131ms,26 Million samples
60Hz clock:      > 131,000 cycles,36 MINUTES,216 Billion samples
  
```

Compression:

```

-----
Real-time in hardware
Tri-mode
Dynamic, cycle-by-cycle mode selection
  
```

**DV3200**

```

Channels:         - 18

Sample Rate:      - 200 MHz
  
```

Full Resolution Capture:

```

-----
Minimum:          512K (x18) @ 5ns = 2.6 ms
Maximum:          (2^53)/3 (or 3x10^15) @ 5ns = 173 Days

Serial (assumes > .01 Baud, < 85 sec. between bits/bytes)
  RS232:          > 31,000 characters
  SYNC:           > 8,000 characters

Serial (assumes > 3K Baud, < 327 us. between bits/bytes)
  RS232:          > 47,000 characters
  SYNC:           > 12,000 characters
  I2C:            > 10,000 characters

8051 cycles:     > 40,000 code fetches
1MHz clock:      > 131,000 cycles,131ms,26 Million samples
60Hz clock:      > 131,000 cycles,36 MINUTES,216 Billion samples
  
```

Compression:

```

-----
Real-time in hardware
Tri-mode
Dynamic, cycle-by-cycle mode selection
  
```

**DV3400 - 200MHz**

```

Channels:         - 36

Sample Rate:      - 200 MHz
  
```

Full Resolution Capture:

```

-----
Minimum:                512K (x36) samples, @ 5ns = 2.6ms
Maximum:                2^52 (4.5x10^15) samples @ 5ns = 260 DAYS

Serial (assumes > .01 Baud, < 85 sec. between bits/bytes)
  RS232:                > 47,000 characters
  SYNC:                 > 12,000 characters
  I2C:                  > 10,000 characters

8051 cycles:           > 40,000 code fetches
1MHz clock:            > 131,000 cycles,131ms,26 Million samples
60Hz clock:            > 131,000 cycles,36 MINUTES,216 Billion samples

Compression:
-----
Real-time in hardware
Tri-mode
Dynamic, cycle-by-cycle mode selection

```

### DV3400 - 400MHz

```

Channels:                - 18

Sample Rate:            - 400 MHz

Full Resolution Capture:
-----
Minimum:                1M (x18) samples, @ 2.5ns = 2.6ms
Maximum:                2^53 (9x10^15) samples @ 2.5ns = 260 DAYS

Serial (assumes > .01 Baud, < 85 sec. between bits/bytes)
  RS232:                > 47,000 characters
  SYNC:                 > 12,000 characters
  I2C:                  > 10,000 characters

8051 cycles:           > 40,000 code fetches
1MHz clock:            > 131,000 cycles,131ms,52 Million samples
60Hz clock:            > 131,000 cycles,36 MINUTES,432 Billion samples

Compression:
-----
Real-time in hardware
Tri-mode
Dynamic, cycle-by-cycle mode selection

```

**Final note:** the data is compressed in real-time with dedicated hardware and is NEVER fully de-compressed (which could result in data files much larger the available hard-drive capacities). DigiView software transfers the entire compressed data buffer from the hardware to internal PC memory in compressed form. This allows us to transfer the entire buffer in about 1 second. The waveform display routines fetch only enough data from the compressed memory buffer to fill the viewable portion of the display screen and even that is compressed.

## 9.2 DigiView Hardware Specifications

	DV3100	DV3200	DV3400
Power Source	USB	USB	External
Connection Type	USB 2.0	USB 2.0	USB 2.0
Transfer Speed	480 Mbps	480 Mbps	480 Mbps
Idle power	<.5 Watt	<.5 Watt	2.5 Watt
Active Power	< 2.5W	< 2.5W	< 7 Watt
Sample Rate	100 MHz(10ns)	100 MHz(10ns)	200 Mhz(5ns) 400 MHz(2.5ns)
Channels	18	18	18 or 36
Sample Count	Varies with data due to real-time compression	Varies with data due to real-time compression	Varies with data due to real-time compression
Samples @ 100 Mhz	<b>Min:</b> 512K (x18) @ 10ns = 5.2 ms  <b>Max:</b> (2 <sup>53</sup> )/3 (or 3x10 <sup>15</sup> ) @ 10ns = 347 Days	N/A	N/A
Samples @ 200 Mhz	N/A	<b>Min:</b> 512K (x18) @ 5ns = 2.6 ms  <b>Max:</b> (2 <sup>53</sup> )/3 (or 3x10 <sup>15</sup> ) @ 5ns = 173 Days	<b>Min:</b> 512K (x36) @ 5ns = 2.6 ms  <b>Max:</b> 2 <sup>52</sup> (4.5 x 10 <sup>15</sup> ) @ 5ns = 260 Days
Samples @ 400 Mhz	N/A	N/A	<b>Min:</b> 1M (x18) @ 2.5ns = 2.6 ms  <b>Max:</b> 2 <sup>53</sup> (9 x 10 <sup>15</sup> ) @ 2.5ns = 260 Days
Raw Memory	9 Mbit (512K x 18)	9 Mbit (512K x 18)	18 Mbit (512K x 36)
Trigger position	Selectable (0-100%)	Selectable (0-100%)	Selectable (0-100%)
Trigger Sequencers	Configurable:  1@16 stages OR 4@4 stages OR 2@8 stages OR 1@8 + 2@4 stages OR 1@12 + 1@4 stages	Configurable:  1@16 stages OR 4@4 stages OR 2@8 stages OR 1@8 + 2@4 stages OR 1@12 + 1@4 stages	Configurable:  1@16 stages OR 4@4 stages OR 2@8 stages OR 1@8 + 2@4 stages OR 1@12 + 1@4 stages

	DV3100	DV3200	DV3400
Trigger Match Circuits	<p>8 Universal</p> <p>Each can be configured as:</p> <p><b>Edge Detect</b> (18 bit OR: rising, falling, either)</p> <p><b>Patterns</b> (18 bit AND: 0, 1, X)</p> <p><b>Stable</b> (18 bit)</p> <p>&gt; (18 bit RANGE)</p> <p>&gt;= (18 bit RANGE)</p> <p>&lt; (18 bit RANGE)</p> <p>&lt;= (18 bit RANGE)</p> <p>= (18 bit RANGE)</p> <p>&lt;&gt; (18 bit RANGE)</p>	<p>8 Universal</p> <p>Each can be configured as:</p> <p><b>Edge Detect</b> (18 bit OR: rising, falling, either)</p> <p><b>Patterns</b> (18 bit AND: 0, 1, X)</p> <p><b>Stable</b> (18 bit)</p> <p>&gt; (18 bit RANGE)</p> <p>&gt;= (18 bit RANGE)</p> <p>&lt; (18 bit RANGE)</p> <p>&lt;= (18 bit RANGE)</p> <p>= (18 bit RANGE)</p> <p>&lt;&gt; (18 bit RANGE)</p>	<p>8 Universal</p> <p>Each can be configured as:</p> <p><b>Edge Detect</b> (36 bit OR: rising, falling, either)</p> <p><b>Patterns</b> (36 bit AND: 0, 1, X)</p> <p><b>Stable</b> (36 bit)</p> <p>&gt; (36 bit RANGE)</p> <p>&gt;= (36 bit RANGE)</p> <p>&lt; (36 bit RANGE)</p> <p>&lt;= (36 bit RANGE)</p> <p>= (36 bit RANGE)</p> <p>&lt;&gt; (36 bit RANGE)</p>
Match Duration	<p>Yes</p> <p>- 1 per match circuit</p> <p>- up to 1M samples each</p>	<p>Yes</p> <p>- 1 per match circuit</p> <p>- up to 1M samples each</p>	<p>Yes</p> <p>- 1 per match circuit</p> <p>- up to 1M samples each</p>
Trigger Pass Count	Yes (up to 1 Million per Sequencer stage)	Yes (up to 1 Million per Sequencer stage)	Yes (up to 1 Million per Sequencer stage)
Trigger Output Sources	<p>Seq 1</p> <p>OR Seq 2</p> <p>OR Seq 3</p> <p>OR Seq4</p> <p>OR (8 input sum-of-8 input products of all 8 match circuits)</p>	<p>Seq 1</p> <p>OR Seq 2</p> <p>OR Seq 3</p> <p>OR Seq4</p> <p>OR (8 input sum-of-8 input products of all 8 match circuits)</p>	<p>Seq 1</p> <p>OR Seq 2</p> <p>OR Seq 3</p> <p>OR Seq4</p> <p>OR (8 input sum-of-8 input products of all 8 match circuits)</p>
External Trigger Output	No	No	Yes, (BNC connector)
Threshold Circuits	1	1	2 (1 for for each group of 18 channels)
Threshold Range	Adjustable (0.5V to 2.8V)	Adjustable (0.5V to 2.8V)	Adjustable (-6V to +6V)
Threshold Accuracy	+/- 250mv	+/- 250mv	+/- 250mv
Maximum voltage (Continuous, all channels)	+/-20 Volts	+/-20 Volts	+/-50 Volts
Impedance	<p>&gt;50KOhm // &lt;10pf (0-3.3V)</p> <p>&gt;5KOhm // &lt;10pf</p>	<p>&gt;50KOhm // &lt;10pf (0-3.3V)</p> <p>&gt;5KOhm // &lt;10pf</p>	50KOhms // < 3pf

	<b>DV3100</b>	<b>DV3200</b>	<b>DV3400</b>
	(<0, >3.3V)	(<0, >3.3V)	
Anti-static protection	Yes	Yes	Yes
GCP (Ground current Protection, ground lead to +- voltage)	Yes +-12 Volts	Yes +-12 Volts	Yes +-12 Volts
Size (LxWxH)	4.75" x 2.8" x .75"	4.75" x 2.8" x .75"	5.0" x 4.25" x 1.40"
Materials	Extruded Aluminum	Extruded Aluminum	Extruded Aluminum
Buffer Size	Selectable 1-100%	Selectable 1-100%	Selectable 1-100%

# Index

## - @ -

@ 57

## - [ -

[ 82

## - ] -

] 82

## - < -

< 82

## - > -

> 82

## - 1 -

1 82

## - 2 -

2 82

## - 3 -

3 82

## - 4 -

4 82

## - 5 -

5 82

## - 6 -

6 82

## - 9 -

90GBytes 132

## - A -

A 82

Abort Button 113

Acquisition Options 5

Active Marker 75

Active Search 93

Add a new Signal 7

Add new Signal 7

Alt+C 82

Alt+F 82

Alt+H 82

Alt+S 82

Alt+W 82

Analog 9

Analog Signal 16

Analyzer Options 5, 49

Analyzer State 63

Appendices 132

Arbitrary Snap 72

Arbitrary Snap to center 72

Armed 63

Associated Channels 7

Asynchronous 9

Asynchronous Signal 13

Authenticode 2

Auto Run 61

Auto Save/Restore 57, 129

Auto Search 53, 94

Auto-Snap 75

Auto-Snap & Bring to Center 75

## - B -

Bandwidth shortage 68

baud rate 13

Bird's-Eye View 72, 81

Bookmark 64

Boolean 9  
Boolean Signal 11  
Bring to Center 72, 75  
Buffer Size 49  
Buffer Usage 63  
Bus 7, 9  
Bus Signal 12  
Bus Signal Format 72  
bus-powered 5  
bus-powered hub 2  
BUTTONS 107

## - C -

C 82  
Cancel Button 125  
capture buffer 7  
Capture History Options 53  
Capture History Search 64  
Capturing Data 61  
CDROM 2  
Center Line 57  
Changing the Signal Color 7  
Changing the Signal order 7  
Channel Monitor 49  
Channel Selection 11, 12, 13, 16, 17, 20, 22  
circular queue 61  
Clear 72  
Clear All Button 114  
clear the buffer 63  
Click and drag to marquee 79  
CLK 20, 22  
Clock (SCL) 17  
Clock Channel 25  
Clock Edge 20, 22  
Close Button 113  
Collapse 72  
Color Selection 25  
Color Selection & Examples 11, 12, 13, 16, 17, 20, 22  
Color Themes 5, 55  
color-coded 6  
common ground 7  
communication errors 5  
Communication Settings 13, 22  
compression 7, 114  
compression ratios 7  
CONFIG 6, 7

Configuration options 5  
Configure Print Device 122  
connecting 6  
Connecting Data Lines 5  
Connecting the Data Lines 6  
connectors 6  
Convert Project 129  
create a new signal 7  
cross-linked 90  
Ctrl+Drag 82  
Cursor 75  
Cursors 75  
Custom Baud 13  
Custom Color Themes 55

## - D -

Data 20, 22  
Data (SDA) 17  
Data Compression 114, 117  
Data Lines 6  
Debug Plugins 57  
Decode 17  
Define Searches 91  
Defining Signals and Triggers 5, 7  
defining trigger conditions 5  
Delete History 53  
Delete Signal 7  
Deleting Signals 7  
DELTA mode 84  
DESTINATION DIRECTORY 2  
De-Tabbing a window 106  
Disable Signal Channels 13  
Display Behavior 53  
Display Signals as a BUS 7  
Do Not Change Position 53  
Do Not Save capture History 53  
Dock Sites 105  
Docking a Window 105  
Docking Windows 105  
down-sampling 84  
Drag & drop 72  
Drag to place 75  
dragging a marker 75  
Drop & Bring to Center 75  
Drop Marker 72  
Duration Units 91, 102

**- E -**

Early Trigger 49  
 Edge Match 33  
 Edge Snap 72  
 Edge Snap to center 72  
 EDGE trigger 27  
 Edit Search 93  
 Edit Signal 72  
 Edit Signal Properties 7, 72, 84, 87  
 EITHER EDGE 27  
 Enable 20, 22  
 Enable Signal Channels 11, 12, 13, 16, 17, 20, 22  
 Enable State 20, 22  
 Enabled Status 7  
 Enforce Prefill 49  
 Environment options 5, 57  
 Equal Match 35  
 Estimated Free Disk Space 113  
 EXAMPLE #1 132  
 EXAMPLE #2 132  
 Expand 72  
 Expand order 72, 84  
 expanded channels 117  
 Export 84, 87  
 Export All 117  
 Export Button 113  
 export expanded channels 117  
 export methods 113  
 Export To 113  
 Exported Data Example 114, 116, 117  
 Exporting 113  
 Exporting All Signal Data 114  
 Exporting from List Windows 116  
 Exporting from Table Windows 117  
 external power supply 5

**- F -**

FALLING EDGE 27  
 Field Idle Timeout 22, 25  
 Field Length 22, 25  
 Field Mode 97  
 Field Separator 114, 116, 117  
 Field SYNC 22  
 Field/Frame modes 82

FLAT BUTTONS 107  
 Floating a tabbed window 106  
 Floating a window 105  
 Frame Idle Timeout 13, 20, 22, 25  
 Frame Length 13, 22, 25  
 Frame Mode 97  
 Frame on 9bit Address flag 13  
 Frame on SS 25  
 Frame SYNC 20, 22  
 Frame SYNC Channel 20  
 Free Run/No trigger 27  
 Free Scroll 72  
 Full Buffer 63

**- G -**

Glitch Filter 13  
 Global Search 91, 93  
 Goto 79  
 Goto M1+M2 79  
 Goto M3+M4 79  
 Goto M5+M6 79  
 GOTO marker 75, 82  
 Goto Trigger 79  
 Graphical Configuration 28  
 Greater Than Match 39  
 Greater Than or Equal Match 42  
 ground 6  
 ground wires 7

**- H -**

H 82  
 Halt 61  
 Halt Analyzer 94  
 Halt Options 94  
 Halt Qualifier 94  
 Halt when limitation reached 53  
 Halted 63  
 HALTING 61  
 hardware based compression 132  
 Hardware Status 63  
 high resolution 132  
 History Browsing 64  
 history buffer 64  
 History Menu 64  
 History Monitor 53



History Searching 64  
Horizontal Lines 57  
Hot-Keys 72, 82

## - I -

I 82  
I2C 9  
I2C Signal 17, 87  
IDLE 63  
Include Comments 122, 125  
Include I/O Direction 116  
Include Line Numbers 114, 117  
Include Packet Type 116  
Include Status 116  
Include Time Stamp 114, 116, 117  
independent scrolling 79  
Installing 2  
Installing the Software 2  
Installing the USB Drivers 2  
Insufficient power 68  
Invert CLK/Data 20, 22  
Invert SDA/CLK 17  
Invert Signal Value 11, 12, 13, 16  
Inverted Signal Display 7  
Invoking Searches 93

## - J -

JPEG 121, 125  
JPEG Options 125  
Jump 72  
Jump to Marker 75  
Jump to markers 87

## - L -

Less Than Match 43  
Less Than or Equal Match 46  
LEVEL then EDGE trigger 27  
LEVEL trigger 27  
Limit by Disk Free 53  
Limit by Number 53  
Limit by Size 53  
line numbers 114  
Link 72  
Link / Unlink Waveform Views 79

Link Group 84  
Link Group indicators 90  
Link groups 72, 90  
Linking Views into Time-Relative Groups 72  
List Exports 116  
List View Windows 87  
Local Search 93  
LSB first 22

## - M -

Mark the match point 91  
Marker Selection 55  
Marker Tack 75  
marker visibility 55  
Markers 75  
Marque to Zoom 72  
Marquee Zoom 72, 79  
Match 97  
match circuits 31  
Match Duration 102  
Match Pattern Format 91, 102  
Match Point 96  
match sequence 96  
Match Type 31  
Match Types 31  
Maximum Disk Size for Capture History 53  
Maximum Number of Captures to keep 53  
Measurement Window 75  
measurements 75  
micro-grabber hooks 6  
Minimum Disk Size 53  
Minimum Post-Trigger Buffer 49  
MISO Channel 25  
Monitor signals 61  
MOSI Channel 25  
MSB First 13  
Multi-channel signals 84  
multiple channels 12

## - N -

Navigating and Analyzing the Data 72  
Navigation, Markers & Buttons 72  
New 129  
New List 87  
new position 7

New Project 129  
 New Search Manager 93  
 New Table 84  
 Next View 79  
 Noise Filter 17  
 Not Equal Match 38  
 Notify when Save Needed 57  
 Numerical Format 114, 116, 117

## - O -

O 82  
 Open 129  
 Orientation 122  
 OutPut To 122, 125  
 Over-riding Docking 105  
 Overwrite when limitation reached 53

## - P -

P 82  
 packet values 91  
 Page 72  
 Parity 13  
 Parity/9bit Address flag 13  
 Partial(P) Fields 25  
 PAT 63  
 PATTERN 27  
 Pattern Match 32  
 pattern matches 91  
 Pattern Searches 96, 102  
 PFX 63  
 PH 63  
 physical channels 5, 7  
 physical layout of the cable 6  
 physical logic channels 9  
 PINOUT 6  
 Play Event Sounds 57  
 Play Trigger Sound 57  
 Post Filling 63  
 Post-Filling 63  
 Post-Trigger Buffer 49  
 Power LED 68  
 Powered 63  
 POWERED HUB 2, 5  
 Pre Filling 63  
 pre-filling 61

preview 61, 114  
 preview a saved image 125  
 Previous View 79  
 Print 72, 84, 87, 122  
 Print window 121  
 Printing 121  
 Printing Options 122  
 Progress indicator 113  
 Project Settings 7

## - Q -

qualified trigger 27  
 Qualifier 20  
 Quick Select Flags 75

## - R -

R 82  
 real-time hardware based compression 132  
 Reference Line for @ 57  
 Re-Frame on BREAK 13  
 rename the signal 7  
 Required Disk Space 113  
 Reset Colors 11, 12, 13, 16, 17, 20, 22  
 Reset Custom to Theme 55  
 Reset Row Height 57  
 Reset Row Heights 57  
 Reset Signal Colors 55  
 resistor color-code order 6  
 resolution 84  
 Restore Last File on Startup 57  
 RISING EDGE 27  
 Run 61

## - S -

S 82  
 Sample Mode 49  
 sample rate 84  
 sampling mode 129  
 Save As 129  
 Save as JPEG 72, 84, 87  
 Save As New Project 129  
 Save capture History 53  
 Save Image 125  
 Save Project File 129

- Save Qualifier 94
- Save, No Save and Halt Options 94
- Saving and Restoring 129
- SCL 17
- Scroll 72
- Scroll by 1 79
- Scroll by 5 79
- Scroll Start/End 79
- Scroll To 79
- Scroll to Marker 53
- Scroll to Trigger 53
- SDA 17
- Search 79
- Search Button 93
- Search Description 91
- Search Edit 79
- Search History 64
- Search Manager 91, 93
- Search Manager Windows 93
- Search Manger Searches 93
- Search Marker 91
- Search Name 91
- Search Types 96
- Searches 91
- Searching 93
- Searching the Data 72
- Select All Button 114
- Select Save Location 125
- Selected Colors 55
- Selections on Startup 57
- Sequencer 48
- Sequential Field search 91
- Sequential Frame search 91
- Sequential search 97
- Sequential Searches 96
- serial packets 13
- serial protocol 17
- Set 72
- SET marker 82
- Setting Cursors 75
- Setting the Match Type 31
- Shift+Snap 82
- Show Field Idles 13, 20
- Show Field Names 87
- Show Frame Idles 13, 20
- Show Frames 87
- Show Selections on Startup 57
- Show Time Column 87
- Signal 9
- Signal Colors and Type 7
- Signal Disable 7
- signal editor 7
- Signal Editors 9
- Signal Name 7, 11, 12, 13, 16, 17, 20, 22, 25
- signal options 7
- Signal Properties 72
- Signal Row Order 72
- Signal Selection 114, 117
- signal type 7
- Signal Types 9
- Signals 7
- Skip 97
- Skip Bits 22, 25
- Skip Count 97
- Snap 72
- SNAP LEFT 75
- Snap Markers 72
- SNAP NEAREST 75
- SNAP RIGHT 75
- Snap Signal 72
- Snap to Frames 57, 82
- Snapping 75
- SPI 9
- SPI Signal 25
- square post connectors 6
- SS Channel 25
- Stable Match 34
- Standard-Mode I2C bus 17
- Startup Selections 57
- State 9
- state clock 20
- State Signal 20
- static protection 6
- Status Window 75
- Stop 61
- STOPPING 61
- storage devices 113
- STRETCH to FIT 107
- symbolic names 7
- Sync (skip transitions) 13
- Sync Start of Packet 13, 22
- Synchronized Scrolling 79
- Synchronous 9
- Synchronous Scrolling 72, 90
- Synchronous Signal 22

**- T -**

T 82  
 Tab Orientation 107  
 Tab Rows 107  
 Tab Size 107  
 Tab Style 107  
 Tab Window Options 106, 107  
 Tabbing windows 106  
 Table Exports 117  
 Table View Windows 84  
 TACK Marker 75  
 Theme Selection 55  
 Thresholds 49  
 Time Column 84, 87  
 Time Display 84, 87  
 time format 84, 87, 114  
 Time Range 113  
 Time Synchronized 84, 87  
 Time-Relative Columns 72  
 Time-Relative Groups 72  
 Timestamp 114, 117  
 Toggle Frames 87  
 Toggle Names 87  
 Toggle Time 87  
 Toolbar Buttons 72, 79  
 Transferring 63  
 Trigger condition 61  
 Trigger Configuration 28  
 Trigger Configuration Selection 28  
 trigger criteria 27  
 Trigger Formula 28  
 trigger immediately 27  
 Trigger Selection Editor 49  
 Trigger Thresholds 49  
 Triggered 63  
 Triggers 7, 27  
 Troubleshooting 68  
 Truncated fields 17

**- U -**

Understanding DigiView Compression 132  
 USB cable 5  
 USB connection 5  
 USB Drivers 2

user preferences 5  
 Using Link Groups 90  
 Using Markers 72, 75  
 Using the same channels in multiple definitions 9

**- V -**

Vertical Lines 57  
 Viewing the Data as Graphical Waveforms 72  
 Viewing the Data in Time-Relative Columns 72

**- W -**

waiting for Trigger 63  
 Wave Form viewing modes 11, 12, 13  
 Wave Form Views 57  
 Waveform Association 75  
 Waveform View 79  
 Waveform Views 72  
 WEB Download 2  
 Where to begin Searching 91  
 Window Arrangement 105

**- Z -**

Z 82  
 Zoom 72  
 Zoom In 79  
 Zoom In Max 79  
 Zoom Max 72  
 Zoom Min 72  
 Zoom Out 79  
 Zoom Out Max 79



(972) 272-9392, [www.tech-tools.com](http://www.tech-tools.com)