

LOC	DIST	P	F	ZONE	LTR	DESCRIPTION	DATE	APPD
FT	47				K	REDRAWN & REV PER ECN BD3869	7-30-91	-
					L	ADDED -8 PER NPR 3597 & REV PER BD6295	06/03/92	GS
					M	OBSOLETE -8 PER EC 0020-608-96	18 DEC 96	GS
					N	REV PER EC 0320-137-97	20 AUG 97	PB

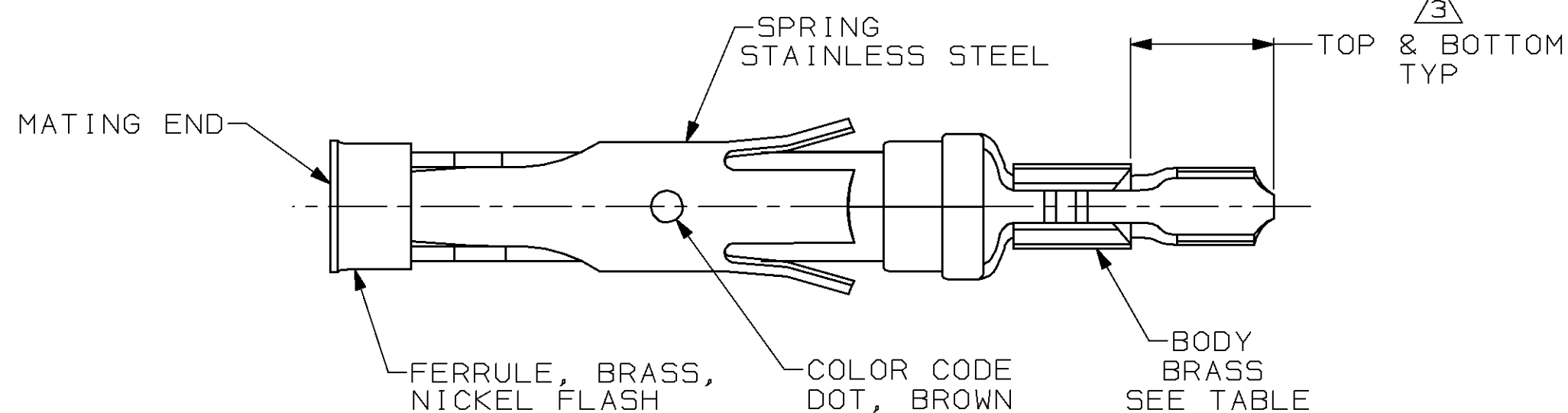

1.689±0.051 DIA
[.0665±.0020]

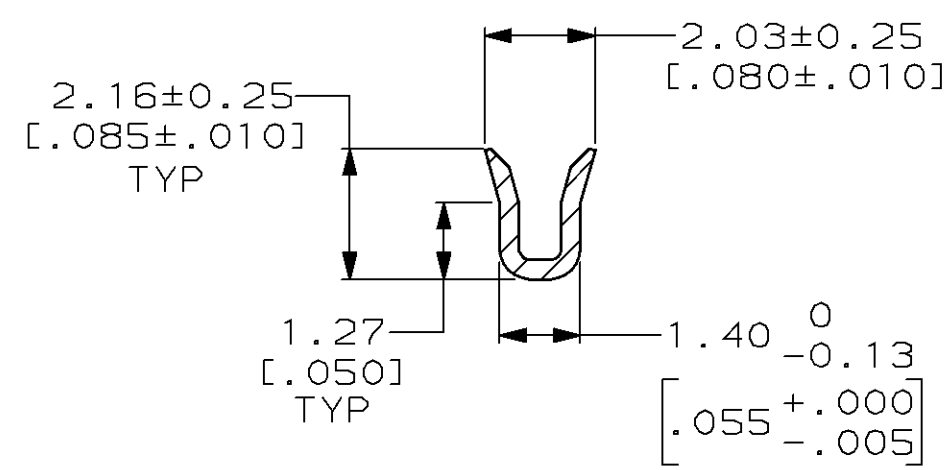
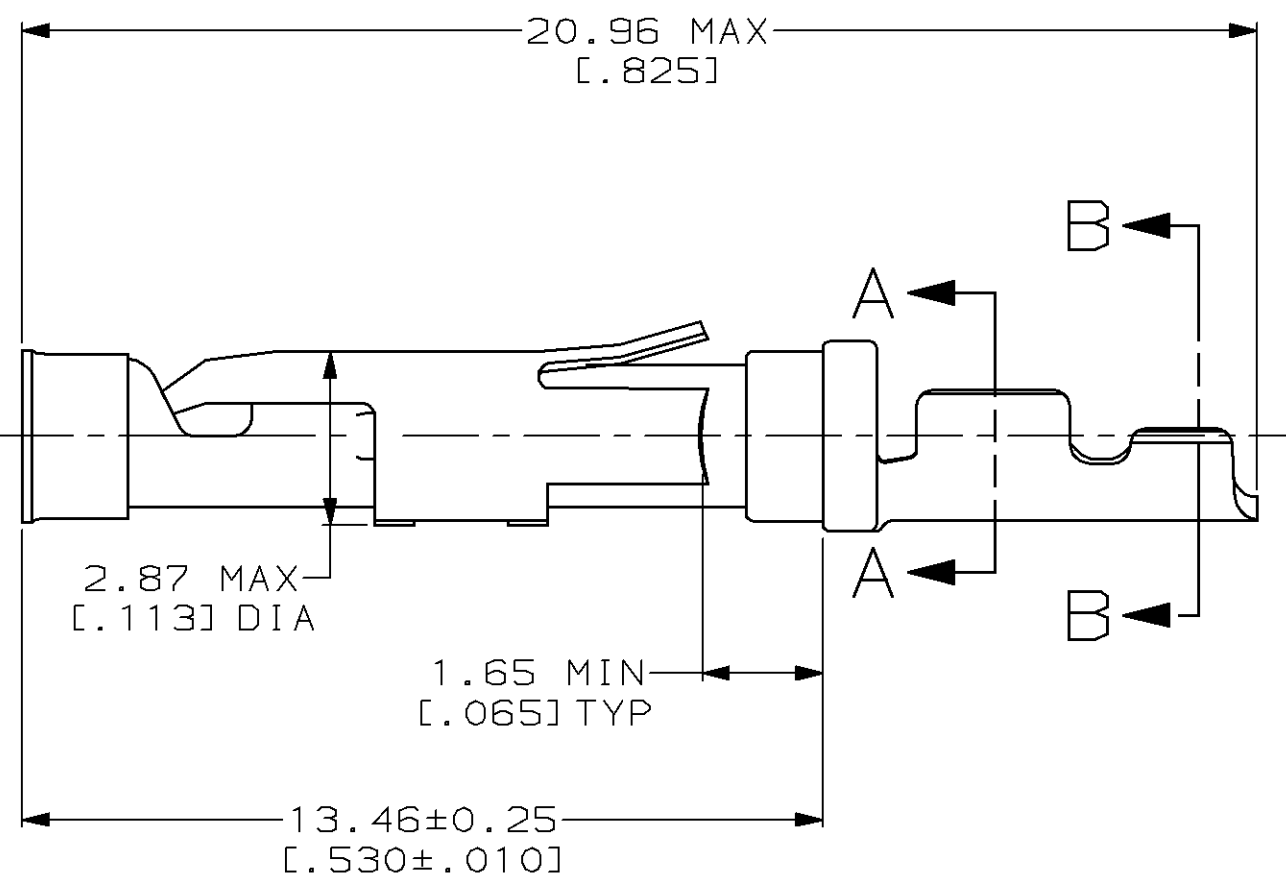

SECTION A-A

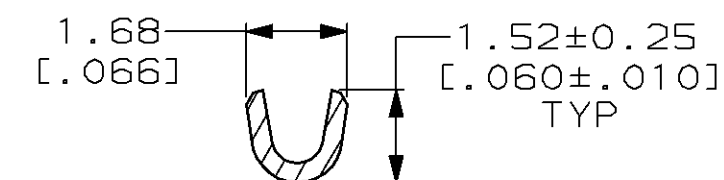

SECTION B-B

- ① 0.76µm [.000030] MIN GOLD PER MIL-G-45204 ON MATING END FOR A LENGTH OF 5.08 [.200] MIN WITH GOLD FLASH ON THE REMAINDER OVER 0.76µm [.000030] MIN NICKEL PER QQ-N-290.
- ② 0.76µm [.000030] MIN GOLD PER MIL-G-45204 ON MATING END FOR A LENGTH OF 5.08 [.200] MIN WITH A UNIFORM GRADIENT TO 0.25µm [.000010] MIN GOLD PER MIL-G-45204 ON THE REMAINDER OVER 0.76µm [.000030] MIN NICKEL PER QQ-N-290.
- ③ GOLD PLATING NEED NOT APPEAR IN THIS AREA.
- 4. WIRE RANGE 26-30 AWG. INSULATION RANGE 0.36[.014]-0.76[.030].
- ⑤ 0.38µm [.000015] MIN GOLD PER MIL-G-45204 ON MATING END FOR A LENGTH OF 5.08 [.200] MIN, 1.27µm [.000050] MIN TIN-LEAD PER MIL-T-10727 FOR A LENGTH OF 5.69 [.224] MIN ON OPPOSITE END, BOTH OVER 1.27µm [.000050] MIN NICKEL PER QQ-N-290 ON ENTIRE CONTACT.

OBsolete	⑤	1-66394-4	66405-8
	①	66394-4	66405-4
	②	66394-1	66405-1
	⑤	BODY FINISH	PART NO
	②	STRIP P/N REF	

DO NOT SCALE PRINT. UNLESS SPECIFIED DIMENSIONS IN mm [INCHES] TOLERANCES ON: 2 PLC DEC ± 0.13[.005] 3 PLC DEC ± - ANGLES ± -	DR 7-30-91 R.SHIREY CHK 9-19-91 R.STONE APPD 9-20-91 J.WESTMAN APPD 9-23-91 W.PARKER	AMP AMP Incorporated Harrisburg, PA 17105-3608	
MATERIAL SEE CALLOUTS	PRODUCT SPEC -	NAME SOCKET ASSEMBLY, LOOSE PIECE, TYPE III+	
FINISH SEE CALLOUTS	APPLICATION SPEC -	SIZE C	CAGE CODE 00779
	WEIGHT -	SCALE 8:1	DRAWING NO 66405
			SHEET 1 OF 1