

GSID080A120B1A5

IGBT Module



Features:

- Low Switching Loss
- Low Saturation Voltage: $V_{CE(sat)} = 1.80V @ I_C = 80A, T_C=25^\circ C$
- 100% RBSOA Tested ($2 \times I_C$)
- Low Stray Inductance
- Mixed voltage component topology
- AlN with DBC ceramic base plate
- Lead Free, Compliant With RoHS Requirement

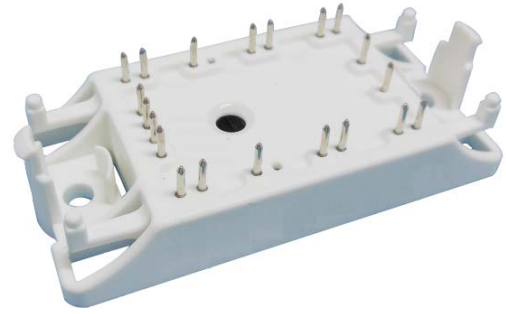

Applications:

- Solar inverter
- UPS

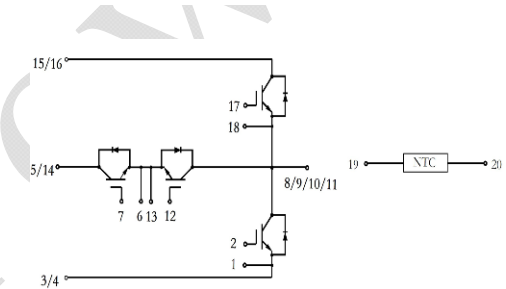

Internal Circuit Diagram

Absolute maximum rated values

Half bridge IGBT ($T_C = 25^\circ C$ unless otherwise specified)

Symbol	Description	Value	Units	
V_{CES}	Collector-Emitter Blocking Voltage	1200	V	
V_{GES}	Gate-Emitter Voltage	± 20	V	
I_C	Continuous Collector Current	$T_C = 80^\circ C$	80	A
		$T_C = 25^\circ C$	160	A
$I_{CM(1)}$	Peak Collector Current Repetitive	$T_J = 175^\circ C$	160	A
P_D	Maximum Power Dissipation (IGBT)	$T_C = 25^\circ C$ $T_{Jmax}=175^\circ C$	1710	W
T_J	Maximum Junction Temperature	175	$^\circ C$	

Half bridge FRD ($T_C = 25^\circ C$ unless otherwise specified)

Symbol	Description	Value	Units	
V_{RRM}	Repetitive Peak Reverse Voltage	1200	V	
I_F	DC Forward Current	40	A	
I_{FRM}	Repetitive Peak Forward Current	80	A	
P_{tot}	Power dissipation per Diode	$T_C = 25^\circ C$ $T_{Jmax}=150^\circ C$	780	W
T_J	Maximum Junction Temperature	150	$^\circ C$	

Neutral point IGBT ($T_C = 25^\circ\text{C}$ unless otherwise specified)

Symbol	Description	Value	Units	
V_{CES}	Collector-Emitter Blocking Voltage	650	V	
V_{GES}	Gate-Emitter Voltage	± 20	V	
I_C	Continuous Collector Current	$T_C = 80^\circ\text{C}$	75	A
		$T_C = 25^\circ\text{C}$	140	A
$I_{CM(1)}$	Peak Collector Current Repetitive	$T_J = 175^\circ\text{C}$	150	A
t_{SC}	Short Circuit Withstand Time	$T_J = 150^\circ\text{C}$	>5	μs
P_D	Maximum Power Dissipation (IGBT)	$T_C = 25^\circ\text{C}$ $T_{Jmax}=175^\circ\text{C}$	1120	W
T_J	Maximum Junction Temperature		175	$^\circ\text{C}$

Half bridge FRD ($T_C = 25^\circ\text{C}$ unless otherwise specified)

Symbol	Description	Value	Units	
V_{RRM}	Repetitive Peak Reverse Voltage	650	V	
I_F	DC Forward Current	50	A	
I_{FRM}	Repetitive Peak Forward Current	100	A	
P_{tot}	Power dissipation per Diode	$T_C = 25^\circ\text{C}$ $T_{Jmax}=150^\circ\text{C}$	410	W
T_J	Maximum Junction Temperature		150	$^\circ\text{C}$

Electrical Characteristics

Half bridge IGBT ($T_J = 25^\circ\text{C}$ unless otherwise specified)

Symbol	Description	Test Conditions	Min.	Typ.	Max.	Units	
I_{CES}	Collector-Emitter Leakage Current	$V_{GE} = 0\text{V}$, $V_{CE} = V_{CES}$ $T_J = 25^\circ\text{C}$			1	mA	
I_{GES}	Gate-Emitter Leakage Current	$V_{GE} = V_{GES}$, $V_{CE} = 0\text{V}$ $T_J = 25^\circ\text{C}$			100	nA	
$V_{GE(th)}$	Gate-Emitter Threshold Voltage	$I_C = 1\text{ mA}$, $V_{CE} = V_{GE}$	4.0	4.5	5.0	V	
$V_{CE(sat)}$	Collector-Emitter Saturation Voltage	$I_C = 80\text{ A}$, $V_{GE} = 15\text{ V}$	$T_J = 25^\circ\text{C}$	1.80	2.00	V	
			$T_J = 150^\circ\text{C}$	2.00	2.20	V	
C_{ies}	Input Capacitance	$V_{CE} = 25\text{ V}$, $V_{GE} = 0\text{ V}$, $f = 1\text{ MHz}$		7.00		nF	
C_{oes}	Output Capacitance			0.44		nF	
$t_{d(on)}$	Turn-on Delay Time	$V_{CC} = 600\text{ V}$, $I_C = 80\text{ A}$, $R_G = 10\ \Omega$, $V_{GE} = \pm 15\text{ V}$, Inductive Load, $T_J = 25^\circ\text{C}$		340		ns	
t_r	Rise Time			70		ns	
$t_{d(off)}$	Turn-off Delay Time			330		ns	
t_f	Fall Time			160		ns	
E_{on}	Turn-on Switching Loss			2.40		mJ	
E_{off}	Turn-off Switching Loss			3.46		mJ	
E_{ts}	Total Switching Loss			5.86		mJ	
$t_{d(on)}$	Turn-on Delay Time		$V_{CC} = 600\text{ V}$, $I_C = 80\text{ A}$, $R_G = 10\ \Omega$, $V_{GE} = \pm 15\text{ V}$, Inductive Load, $T_J = 125^\circ\text{C}$		345		ns
t_r	Rise Time				70		ns
$t_{d(off)}$	Turn-off Delay Time			350		ns	

t_f	Fall Time		220	ns
E_{on}	Turn-on Switching Loss		2.89	mJ
E_{off}	Turn-off Switching Loss		4.79	mJ
E_{ts}	Total Switching Loss		7.68	mJ
Q_g	Internal Gate Resistor	$V_{CE} = 600V, I_C = 80A,$ $V_{GE} = -15V \sim +15V$	855	nC
RBSOA	Reverse Bias Safe Operating Area	$I_C = 160A, V_{CC} = 1050V,$ $V_p = 1200V, R_g = 10 \Omega,$ $V_{GE} = +15V \text{ to } 0V, T_J = 150^\circ C$	Trapezoid	
$R_{\theta JC}$	Junction-To-Case (IGBT part, per Leg)		0.087	$^\circ C/W$

Half bridge FWD ($T_J = 25^\circ C$ unless otherwise specified)

Symbol	Description	Test conditions	Min.	Typ.	Max.	Units
V_{FM}	Forward Voltage	$I_F = 80A,$ $V_{GE} = 0V$	$T_J = 25^\circ C$	1.90		V
			$T_J = 125^\circ C$	2.10		
t_{rr}	Reverse Recovery Time		$T_J = 25^\circ C$	250		ns
			$T_J = 125^\circ C$	360		
I_{rr}	Peak Reverse Recovery Current	$I_F = 80A,$ $di/dt = 1100A/\mu s,$ $V_{rr} = 600V,$ $V_{GE} = -15V$	$T_J = 25^\circ C$	45		A
			$T_J = 125^\circ C$	55		
Q_{rr}	Reverse Recovery Charge		$T_J = 25^\circ C$	5.88		μC
			$T_J = 125^\circ C$	8.63		
E_{rec}	Reverse Recovery Energy		$T_J = 25^\circ C$	2.56		mJ
			$T_J = 125^\circ C$	3.79		
$R_{\theta JC}$	Junction-To-Case (Diode Per Leg)		0.160		$^\circ C/W$	

Neutral point IGBT ($T_J = 25^\circ C$ unless otherwise specified)

Symbol	Description	Test Conditions	Min.	Typ.	Max.	Units
I_{CES}	Collector-Emitter Leakage Current	$V_{GE} = 0V,$ $V_{CE} = V_{CES}$ $T_J = 25^\circ C$			1	mA
I_{GES}	Gate-Emitter Leakage Current	$V_{GE} = V_{GES},$ $V_{CE} = 0V$ $T_J = 25^\circ C$			100	nA
$V_{GE(th)}$	Gate-Emitter Threshold Voltage	$I_C = 2 \text{ mA}, V_{CE} = V_{GE}$	4.0	5.0	6.0	V
$V_{CE(sat)}$	Collector-Emitter Saturation Voltage	$I_C = 75A,$ $V_{GE} = 15V$	$T_J = 25^\circ C$	1.60	1.80	V
			$T_J = 125^\circ C$	1.90		V
C_{ies}	Input Capacitance	$V_{CE} = 25V, V_{GE} = 0V,$ $f = \text{MHz}$		3.60		nF
C_{oes}	Output Capacitance			0.45		nF
$t_{d(on)}$	Turn-on Delay Time	$V_{CC} = 300V, I_C = 75A,$ $R_G = 20\Omega, V_{GE} = \pm 15V,$ Inductive Load, $T_J = 25^\circ C$		100		ns
t_r	Rise Time			90		ns
$t_{d(off)}$	Turn-off Delay Time			240		ns
t_f	Fall Time			90		ns
E_{on}	Turn-on Switching Loss			0.52		mJ
E_{off}	Turn-off Switching Loss			0.90		mJ
E_{ts}	Total Switching Loss			1.42		mJ

$t_{d(on)}$	Turn-on Delay Time	$V_{CC} = 300V, I_C = 75A,$ $R_G = 20\Omega, V_{GE} = \pm 15V,$ Inductive Load, $T_J = 125^\circ C$		100		ns
t_r	Rise Time			90		ns
$t_{d(off)}$	Turn-off Delay Time			250		ns
t_f	Fall Time			110		ns
E_{on}	Turn-on Switching Loss			0.93		mJ
E_{off}	Turn-off Switching Loss			1.43		mJ
E_{ts}	Total Switching Loss			2.36		mJ
Q_g	Internal Gate Resistor	$V_{CE} = 300V, I_C = 75A,$ $V_{GE} = -15V \sim +15V$		260		nC
RBSOA	Reverse Bias Safe Operating Area	$I_C = 150A, V_{CC} = 480V,$ $V_p = 600V, R_G = 15\Omega,$ $V_{GE} = +15V \text{ to } 0V, T_J = 125^\circ C$	Trapezoid			
Symbol	Description	Test Conditions	Min.	Typ.	Max.	Units
SCSOA	Short Circuit Safe Operating Area	$V_{CC} = 300V, V_{GE} = 15V,$ $T_J = 150^\circ C$	5			μs
$R_{\theta JC}$	Junction-To-Case (IGBT part, per Leg)				0.134	$^\circ C/W$

Neutral point FRD ($T_J = 25^\circ C$ unless otherwise specified)

Symbol	Description	Test conditions	Min.	Typ.	Max.	Units
V_{FM}	Forward Voltage	$I_F = 75A,$ $V_{GE} = 0V$	$T_J = 25^\circ C$	1.50		V
			$T_J = 125^\circ C$	1.50		
t_{rr}	Reverse Recovery Time		$T_J = 25^\circ C$	115		ns
			$T_J = 125^\circ C$	160		
I_{rr}	Peak Reverse Recovery Current	$I_F = 75A,$ $di/dt = 1025A/\mu s,$ $V_{rr} = 300V,$ $V_{GE} = -15V$	$T_J = 25^\circ C$	40		A
			$T_J = 125^\circ C$	50		
Q_{rr}	Reverse Recovery Charge		$T_J = 25^\circ C$	2.92		μC
			$T_J = 125^\circ C$	4.7		
E_{rec}	Reverse Recovery Energy		$T_J = 25^\circ C$	0.38		mJ
			$T_J = 125^\circ C$	0.96		
$R_{\theta JC}$	Junction-To-Case (Diode Part, per Leg)			0.302		$^\circ C/W$

Internal NTC Thermistor Characteristic

R_{25}	$T_C = 25^\circ C$	22.7		k Ω
$\Delta R/R$	$T_C = 100^\circ C, R_{100} = 1481 K\Omega$		± 3	%
P_{25}	$T_C = 25^\circ C$	200		mW
$B_{25/50}$	$R_2 = R_{25} \exp[B_{25/50}(1/T_2 - 1/(298.15K))]$	3950		K
$B_{25/80}$	$R_2 = R_{25} \exp[B_{25/80}(1/T_2 - 1/(298.15K))]$	4000		K

Module

	Description		Min	Typ	Max	Unit
V _{iso}	Isolation Voltage(All Terminals Shorted)	f = 50Hz, 1minute	2500			V
T _J	Maximum Junction Temperature				175	°C
T _{JOP}	Maximum Operating Junction Temperature Range		-40		+150	°C
T _{stg}	Storage Temperature		-40		+125	°C
R _{θCS}	Case-To-Sink (Conductive Grease Applied)			0.1		°C/W
T	Mounting Screw:M4		1.0		1.5	N·m
G	Weight			25		g

Half bridge IGBT and half bridge FRD

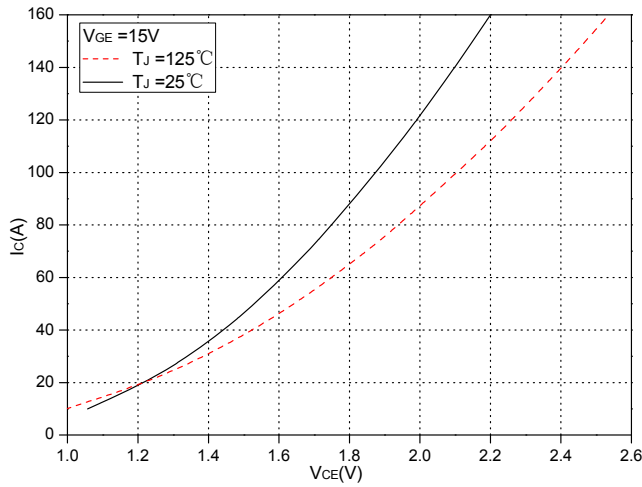

Fig.1 Typical Saturation Voltage Characteristics

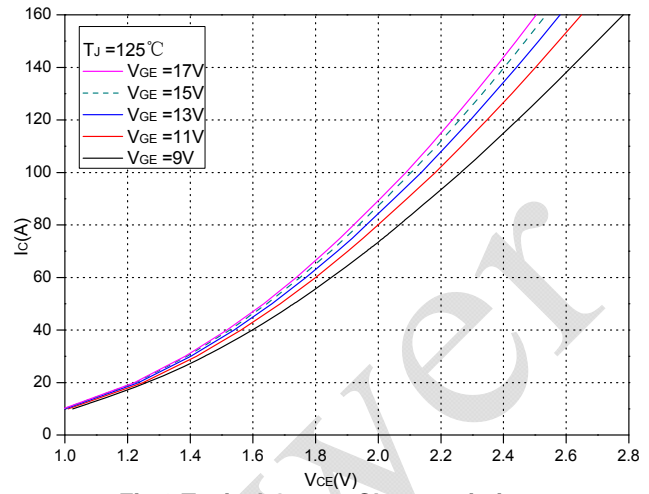

Fig.2 Typical Output Characteristics

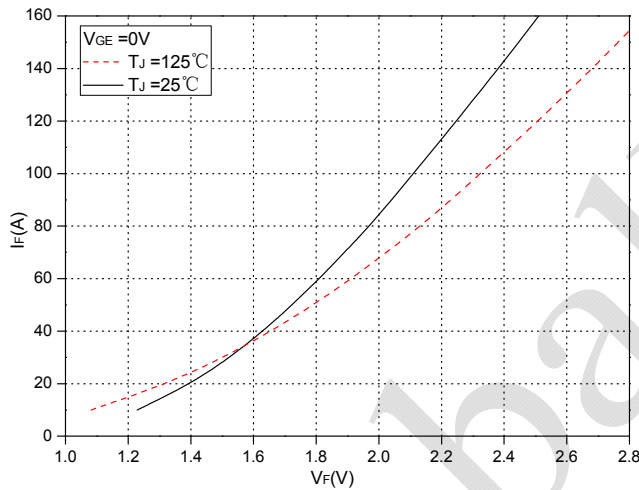

Fig.3 Forward Characteristics of FWD

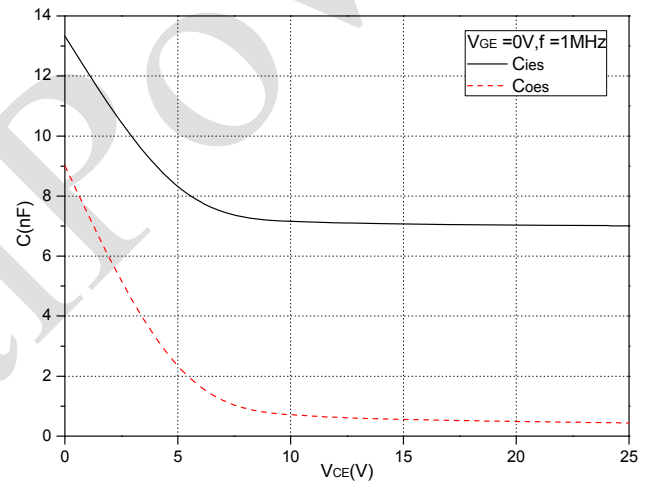

Fig.4 Capacitance Characteristics

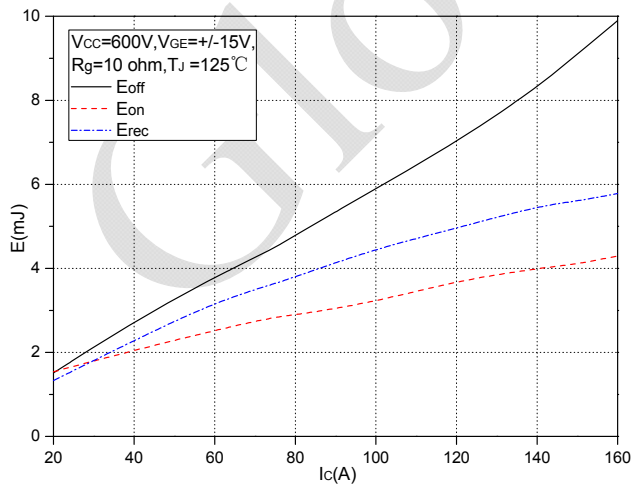

Fig.5 Typical Switching Loss vs. Collector Current

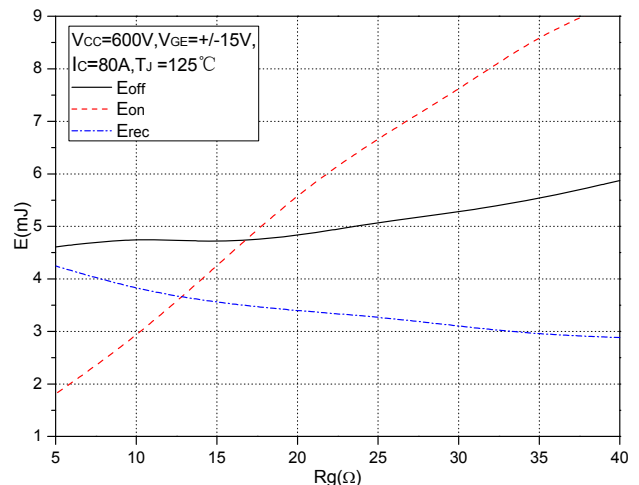

Fig.6 Typical Switching Loss vs. Gate Resistance

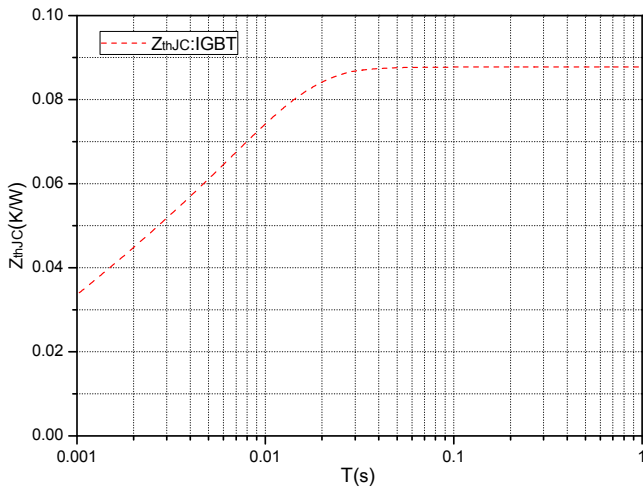

Fig.7 Transient thermal impedance (IGBT)

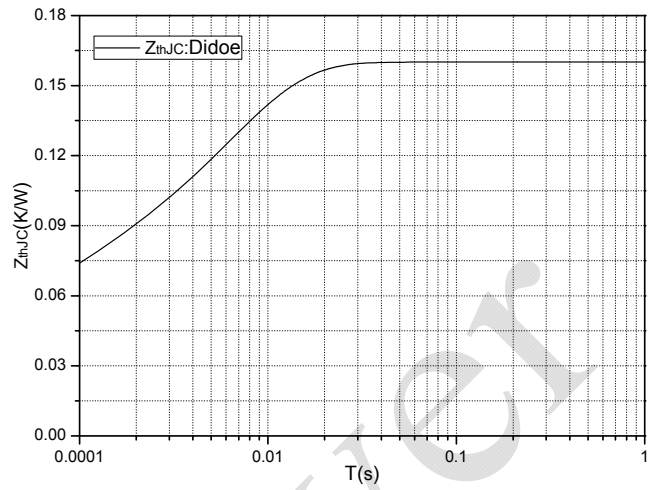

Fig.8 Transient thermal impedance (Diode)

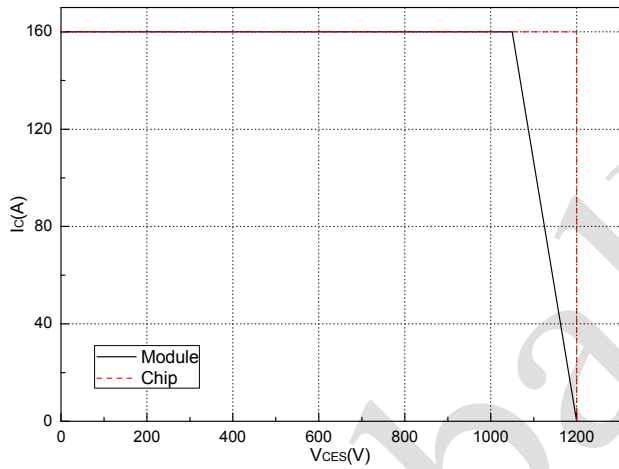

Fig.9 Reverse Bias Safe Operation Area (RBSOA)

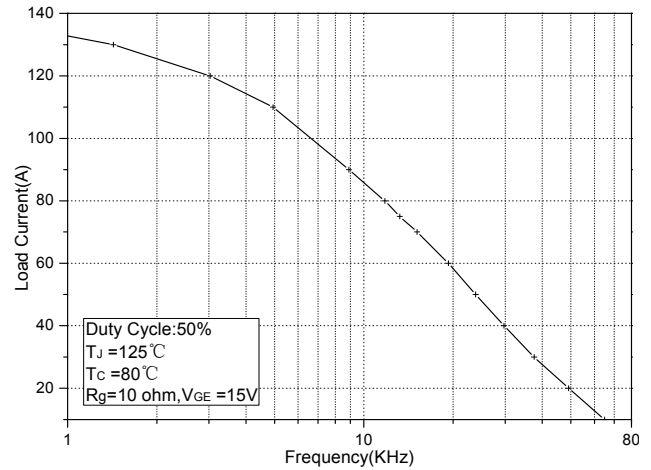

Fig.10 Typical Load Current vs. Frequency

Neutral point IGBT and neutral point FRD:

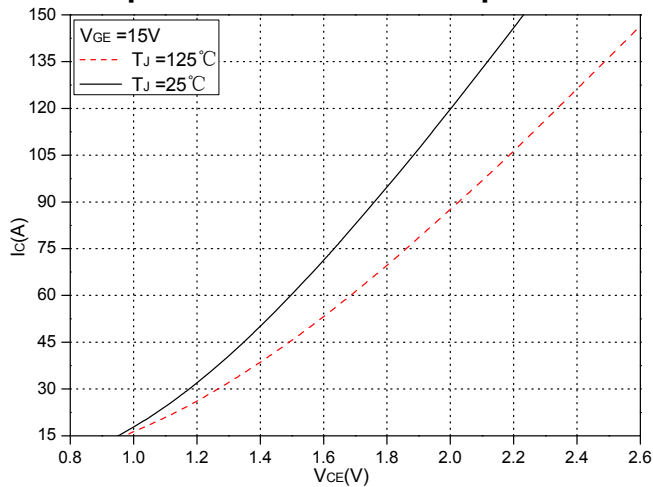

Fig.11 Typical Saturation Voltage Characteristics

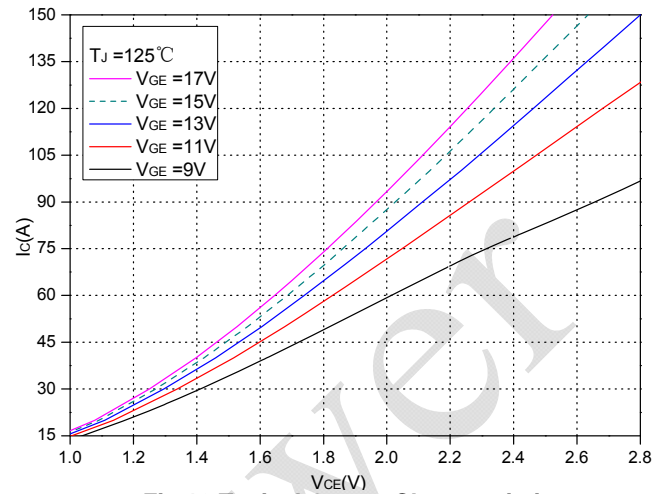

Fig.12 Typical Output Characteristics

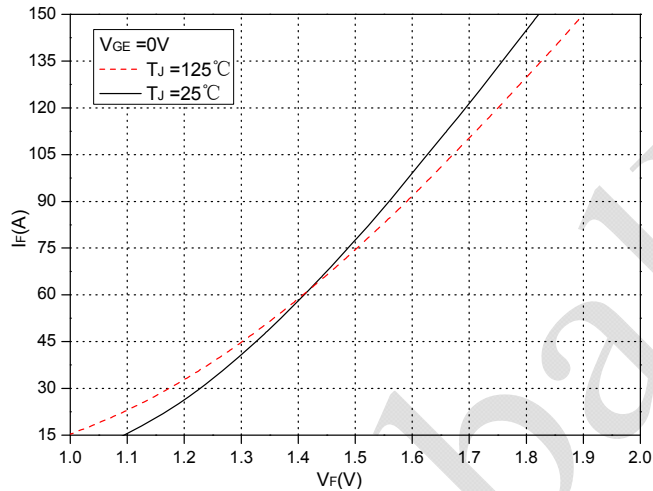

Fig.13 Forward Characteristics of FWD

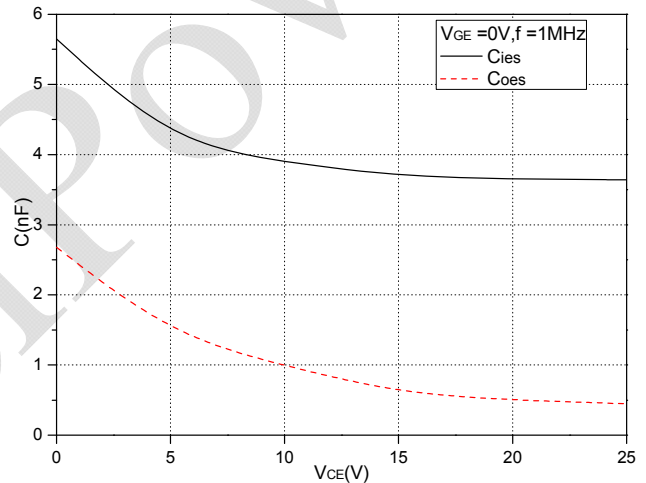

Fig.14 Capacitance Characteristics

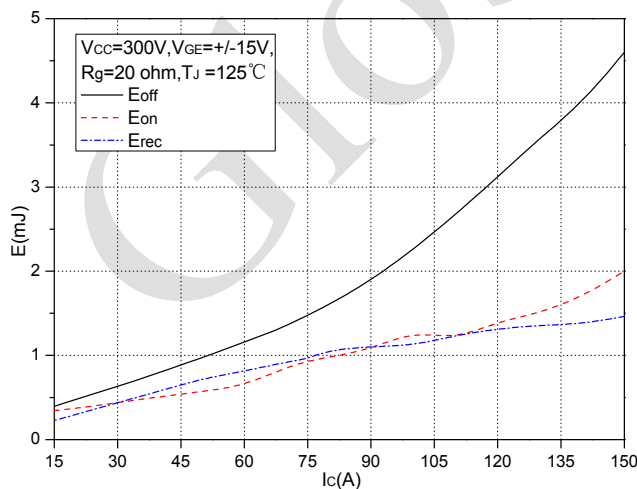

Fig.15 Typical Switching Loss vs. Collector Current

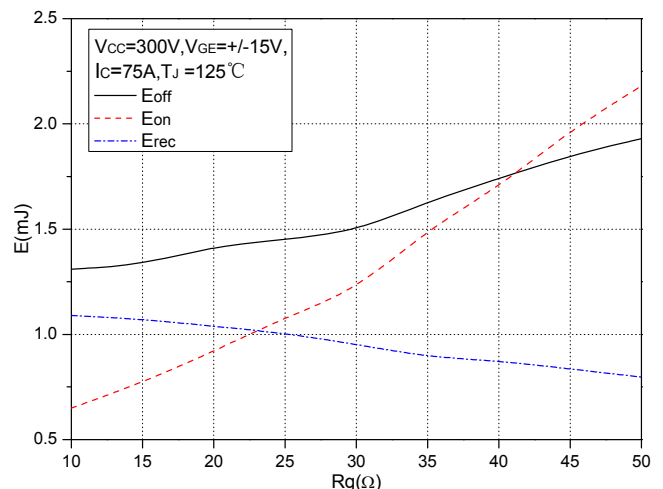

Fig.16 Typical Switching Loss vs. Gate Resistance

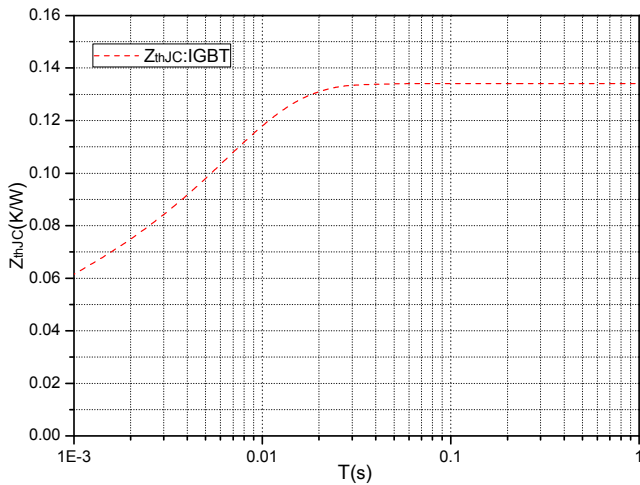

Fig.17 Transient thermal impedance (IGBT)

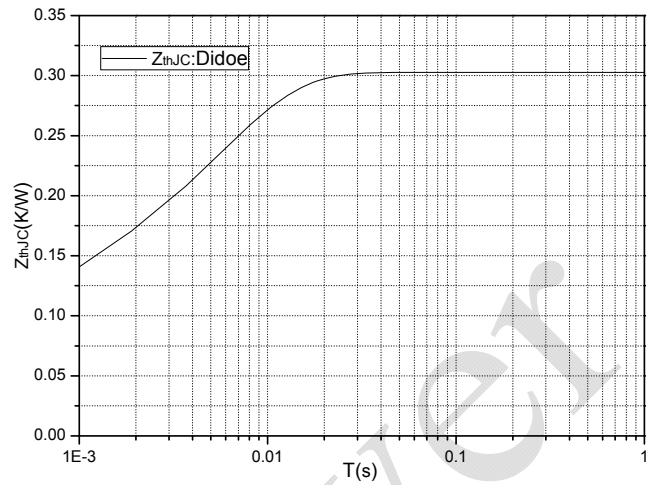

Fig.18 Transient thermal impedance (Diode)

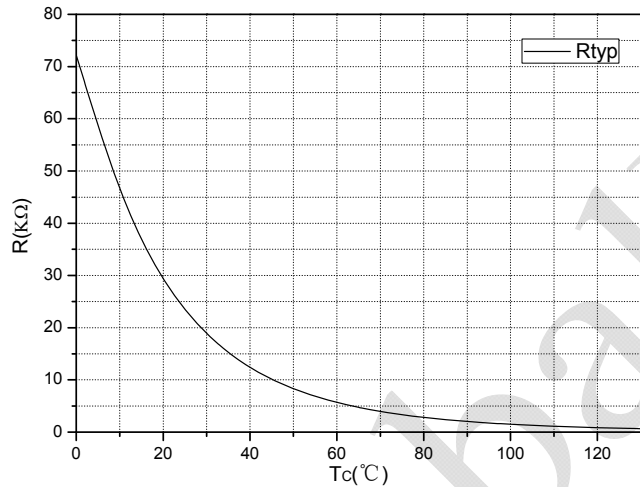

Fig.19 NTC Temperature characteristics

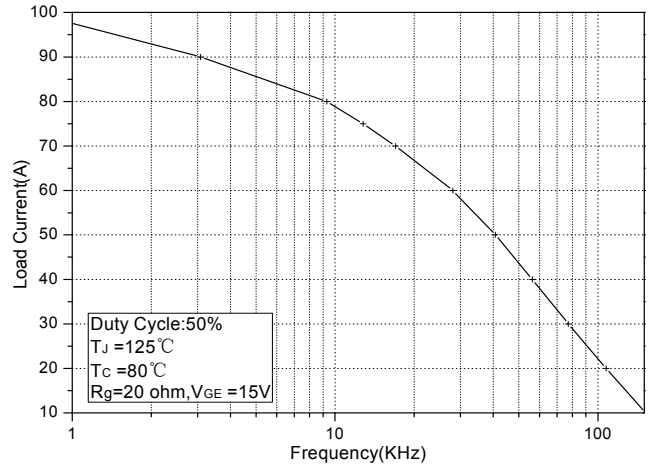
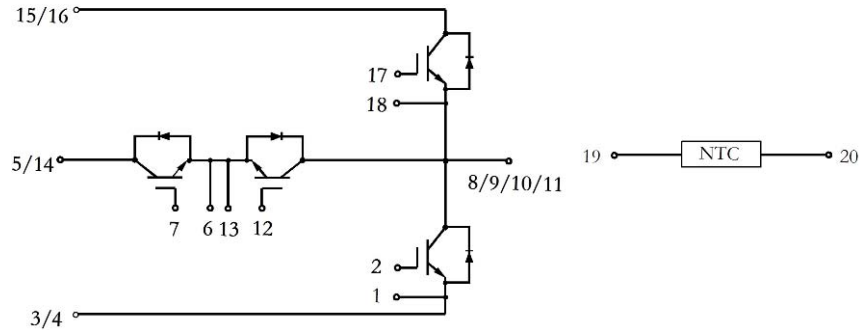
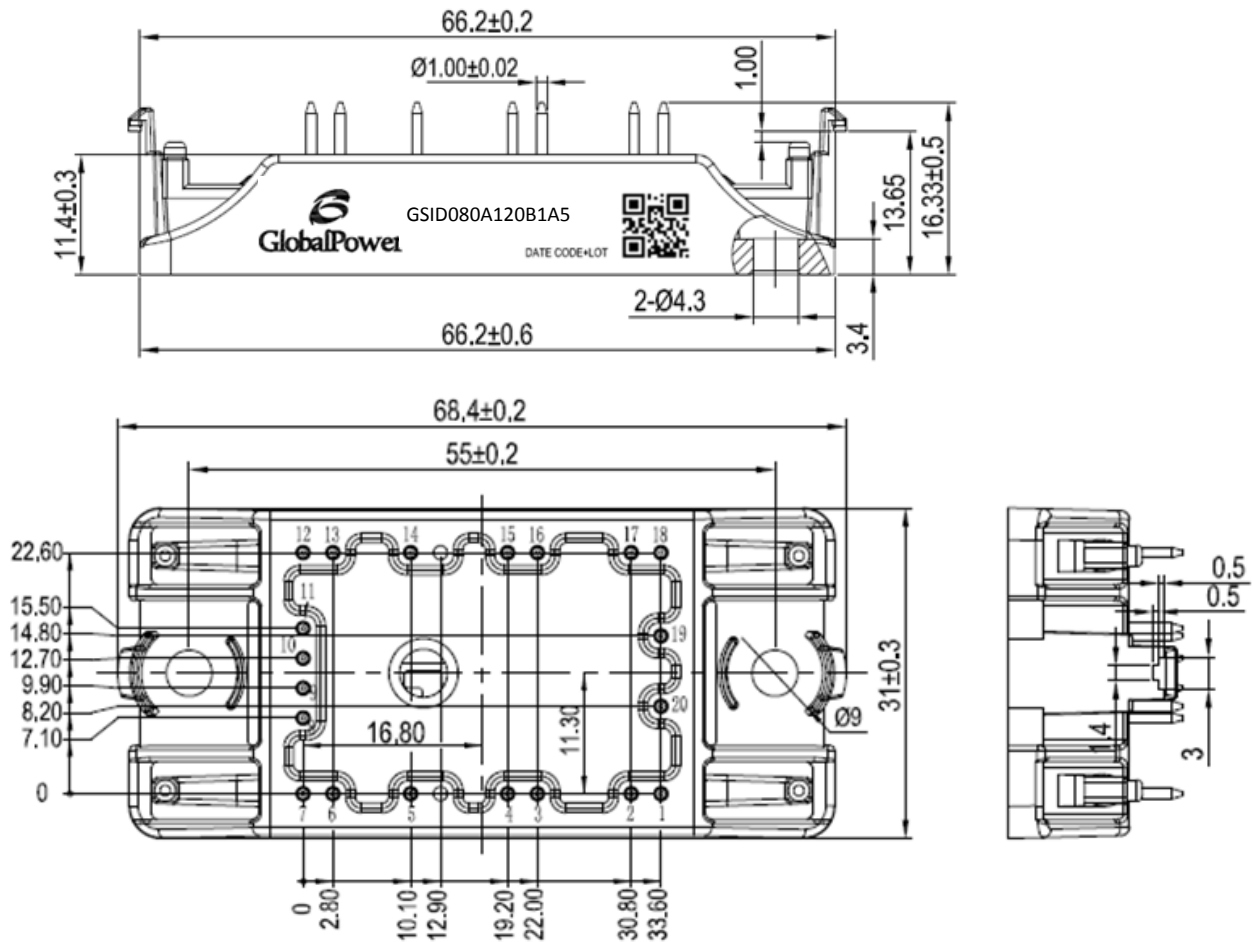

Fig.20 Typical Load Current vs. Frequency

Internal Circuit Diagram:



Package Outline (Unit: mm):



Revision History

Date	Revision	Notes
8/11/2015	0.1	Initial release

Global Power Technologies Group

20692 Prism Place
 Lake Forest, CA 92630
 TEL (949) 207-7500
 FAX (949) 613-7600
 E-mail: info@gptechgroup.com
 Web site: www.gptechgroup.com



Notes

- RoHS Compliance**
 The levels of RoHS restricted materials in this product are below the maximum concentration values (also referred to as the threshold limits) permitted for such substances, or are used in an exempted application, in accordance with EU Directive 2011/65/EC (RoHS2), as implemented March, 2013. RoHS Declarations for this product can be obtained from the Product Documentation sections of www.gptechgroup.com.
- REACH Compliance**
 REACH substances of high concern (SVHCs) information is available for this product. Since the European Chemical Agency (ECHA) has published notice of their intent to frequently revise the SVHC listing for the foreseeable future, please contact our office at GPTG Headquarters in Lake Forest, California to insure you get the most up-to-date REACH SVHC Declaration.
 REACH banned substance information (REACH Article 67) is also available upon request.
- This product has not been designed or tested for use in, and is not intended for use in, applications implanted into the human body nor in applications in which failure of the product could lead to death, personal injury or property damage, including but not limited to equipment used in the operation of nuclear facilities, life-support machines, cardiac defibrillators or similar emergency medical equipment, aircraft navigation or communication or control systems, or air traffic control.
- To obtain additional technical information or to place an order for this product, please contact us. The information in this datasheet is provided by Global Power Technologies Group. GPTG reserves the right to make changes, corrections, modifications, and improvements of datasheet without notice.