

PART NUMBER	REV	FIRST USED	POWER UNIT	FEED TYPE	DESCRIPTION
1855587-1	B	122500-1	LEADMAKER	POST FEED	CUTS CARRIER
1855587-2	B	565435-5	BENCH MODEL K	PRE FEED	CUTS CARRIER
1855587-3	B	354500-1	BENCH MODEL G	PRE FEED	CUTS CARRIER
7-1855587-7	A	-	-	-	SPARE PARTS

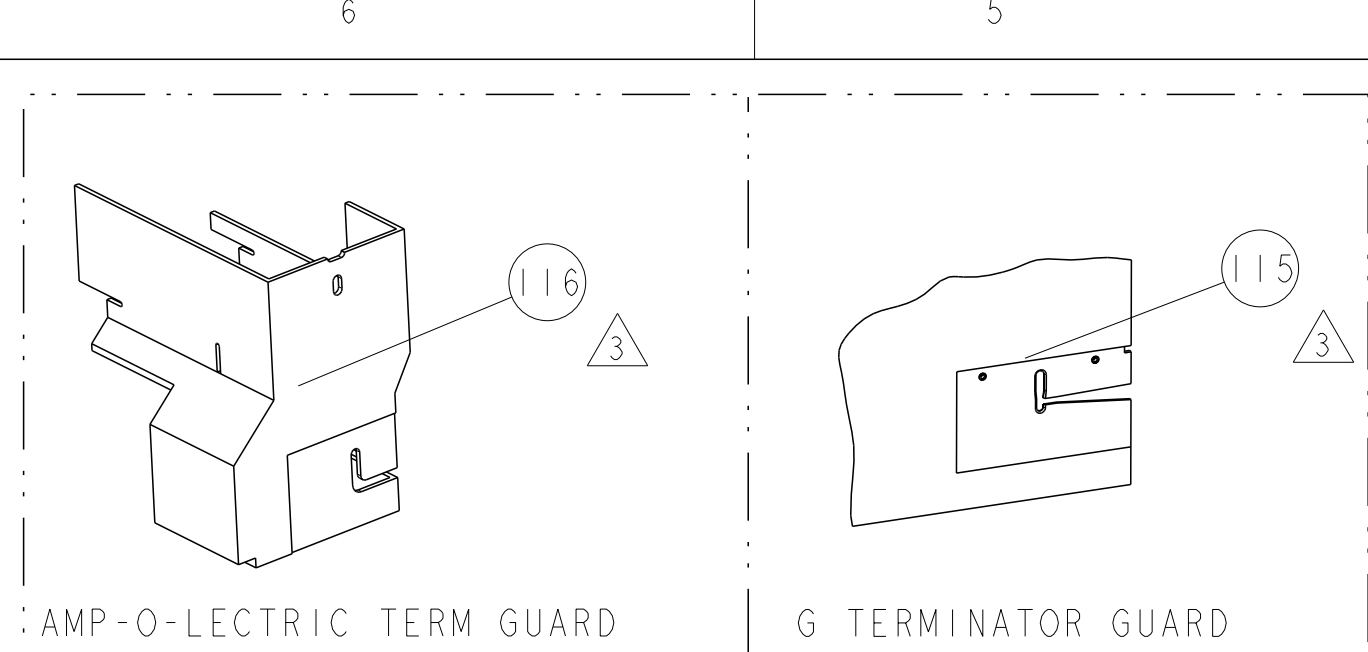

TERMINAL NAME: SHIELD, SHELL, BARREL			
TE PN	TE TERMINAL - TE CRIMP SPECS	REF SETTING	
1823899		CRIMP HEIGHT	WIRE SIZE
-		3.80mm+ .10/- .10 [.150+ .004/- .004]	Ø3.3 BRAID
-		CRIMP	SIZE
-		WIRE	TYPE
-		INSUL	RANGE
WIRE STRIP LENGTH	TERM APPL SPEC	FEED	APPLICATOR INSTRUCTIONS
17.60-18.40	-	11.50	408-8040
			SET UP GAGE
			458637-1

LOC	DIST	REV	DATE	BY	APPD
A	66	1	28OCT2010	ROW	TE
		2	28OCT2011	MY	GB

- 1 RECOMMENDED SPARE PARTS
- 2 GREASE LIGHTLY
- 3 GUARD MUST BE IN PLACE WHEN OPERATING APPLICATOR IN A BENCH MACHINE

*** WARNING**
ON INSTALLATION, SET WIRE DISC TO LARGEST WIRE SIZE SETTING. USE OF SETTINGS BELOW MIN. REQUIRED CRIMP HEIGHT SETTING WILL CAUSE DAMAGE TO CRIMP TOOLING.

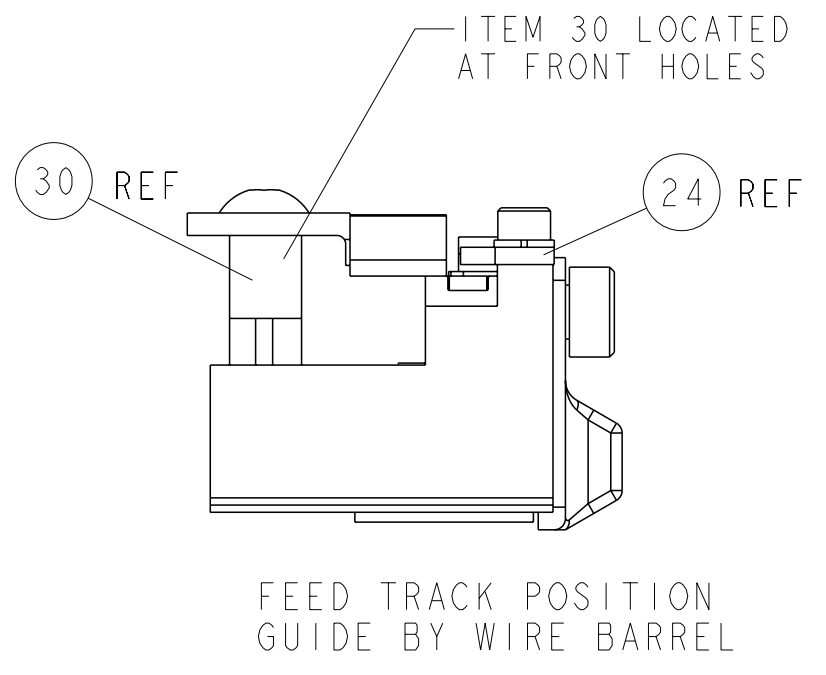
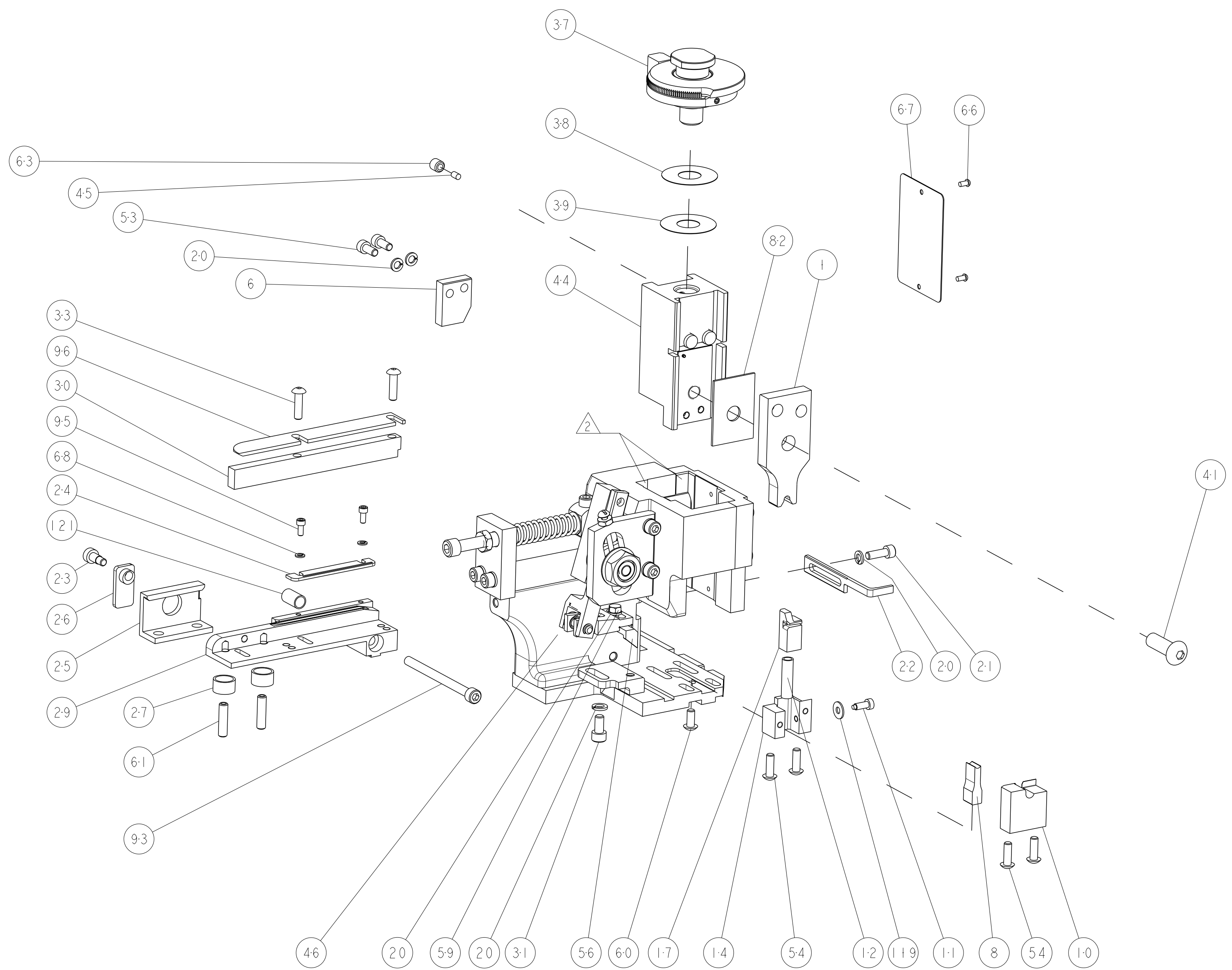

-	1	1	1	-	1-22281-8	SPRING, COMPRESSION	121
-	1	1	1	-	21055-5	WASHER, FLAT, REG NO 6	119
-	-	REF	-	..	455749-1	GUARD WINDOW	116
-	REF	-	-	..	679532-1	INSERT, GUARD	115
-	1	1	1	-	1633630-2	PLATE, STRIP GUIDE	96
-	2	2	2	-	1-21000-3	SCR, SKT HD CAP 4-40 X .250	95
-	1	1	1	-	8-21000-7	SCR, SKT HD CAP 10-32 X 2.500	93
-	1	1	1	-	1-21002-7	SCR, BTN SKT HD CAP 6-32 X .375	91
-	1	1	1	-	1-455888-0	SPACER, CRIMPER	82
-	1	1	1	-	4088040	SF APPL INST 408-8040	72
-	1	1	1	-	217238-1	GENERAL INSTRUCTION PKG	71
-	2	2	2	-	21024-2	WASHER, SPRG LOCK, REG NO 4	68
-	1	1	1	-	461264-5	PLATE, IDENTIFICATION	67
-	2	2	2	-	21017-2	SCREW, DRIVE	66
-	1	1	1	-	21009-2	SCR, SET, SELF LOCKING 1/4-20 X .250	63
-	2	2	2	-	5-21006-6	SCR, SET, CUP POINT 10-32 X .750	61
-	1	1	1	-	22733-8	SCR, BHSC, SELF-LOCKING, 8-32 X .375	60
-	1	1	1	-	2-22603-0	SCR, HEX HD CAP 8-32 X .312	59
-	1	1	1	-	694433-8	FEED PAWL	56
-	4	4	2	-	2-21002-2	SCR, BTN SKT HD CAP 8-32 X .500	54
-	2	2	2	-	2-21000-6	SCR, SKT HD CAP 8-32 X .375	53
-	1	-	-	..	690602-6	CAM, PRE FEED, 1 5/8	49
-	-	1	-	..	690602-5	CAM, PRE FEED, 1 1/8	48
-	-	-	1	-	690501-4	CAM, POST-FEED 1 5/8	47
-	1	1	1	-	459456-1	APPL. BASIC SUB ASSY (SIDE WISE MQCA)	46
-	1	1	1	-	690191-1	PLUG, NYLON	45
-	1	1	1	-	819307-6	RAM, SIDE FEED	44
-	1	1	1	-	7-21002-9	SCR, BTN SKT HD CAP 5/16-24 X 1.00	41
-	1	1	1	-	690125-1	SHIM SUB-ASSY	39
-	1	1	1	-	469367-1	SHIM	38
-	1	1	1	-	879103-4	FINE ADJUST HEAD ASSEMBLY	37
-	2	2	2	-	2-21002-3	SCR, BTN SKT HD CAP 8-32 X .625	33
-	1	1	1	-	21024-5	WASHER, SPRG LOCK, REG NO 10	32
-	1	1	1	-	3-21000-4	SCR, SKT HD CAP 10-32 X .375	31
-	1	1	1	-	1320908-9	SPACER, STRIP GUIDE	30
-	1	1	1	-	1633629-2	PLATE, REAR STRIP GUIDE	29
-	2	2	2	-	1-22284-0	SPRING, COMPRESSION	27
-	1	1	1	-	356835-1	LEVER, DRAG RELEASE	26
-	1	1	1	-	240792-1	DRAG, TERMINAL	25
-	1	1	1	-	690438-1	FRONT STRIP GUIDE	24
-	1	1	1	-	21989-8	SCR, SKT HD SHLDR 3/16 DIA X .250	23
-	-	-	1	-	690472-2	STRIPPER	22
-	1	1	1	-	2-21000-7	SCR, SKT HD CAP 8-32 X .500	21
-	4	4	4	-	21024-4	WASHER, SPRG LOCK, REG NO 8	20
-	1	1	1	-	1-690463-6	FLOATING SHEAR, REAR	17
-	1	1	1	-	690462-1	SHEAR HOLDER, REAR	14
-	-	-	-	..	-	-	13
-	1	1	1	-	3-22280-3	SPRING, COMPRESSION	12
-	1	1	1	-	690461-1	STOP, SHEAR	11
-	1	1	1	-	1633972-1	GUIDE, CABLE	10
-	-	-	-	..	-	-	9
-	1	1	1	-	1633669-9	ANVIL, WIRE	8
-	1	1	1	-	690468-3	DEPRESSOR SHEAR, REAR	6
-	-	-	-	..	-	-	5
-	-	-	-	..	-	-	4
-	-	-	-	..	-	-	3
-	-	-	-	..	-	-	2
-	1	1	1	-	1633723-6	CRIMPER, WIRE O	1

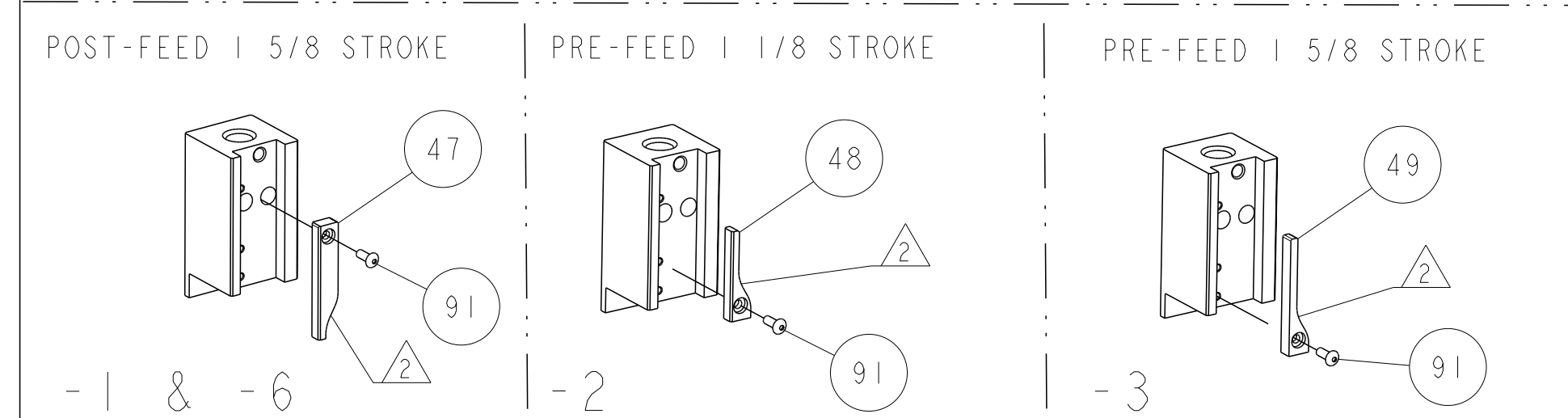

THIS DRAWING IS A CONTROLLED DOCUMENT.

DMN: DR. Q. WILSON 18JUN2010
 CHK: K. J. STAKEM 22JUN2010
 APVD: T. L. ELBIN 24JUN2010

DIMENSIONS: INCHES
 TOLERANCES UNLESS OTHERWISE SPECIFIED:
 9 PLC ±.01
 1 PLC ±0.1
 3 PLC ±0.01
 5 PLC ±0.001
 4 PLC ±0.0001
 ANGLES ±.0001
 FINISH

MATERIAL: -

WEIGHT: -

CUSTOMER ACCESSIBLE PRODUCTION DRAWING

SCALE: 3:5

SHEET: 1 OF 1

REV: B

DESCRIPTION: FINE ADJUST SIDE FEED HDM APPLICATOR

PART NO: A100779

DESCRIPTION: FINE ADJUST SIDE FEED HDM APPLICATOR

ITEM NO: -