

DrGaN^{PLUS} Development Board - EPC9201/3

Quick Start Guide

Optimized Half-Bridge Circuit for eGaN[®] FETs

EPC9203 Top side

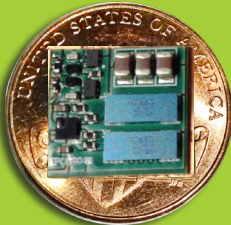

11 mm X 12 mm

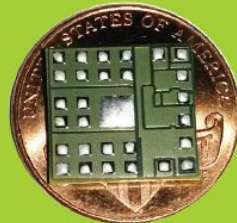

EPC9201 Top side

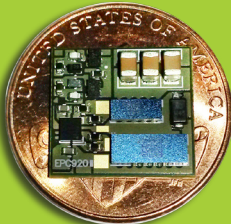

Mounting side

EPC 
EFFICIENT POWER CONVERSION

DESCRIPTION

www.epc-co.com

This development board, measuring 11mm x 12mm, contains two enhancement mode (eGaN[®]) field effect transistors (FETs) arranged in a half bridge configuration with an onboard Texas Instruments LM5113 gate drive. The purpose of these development boards is to simplify the evaluation process by optimizing the layout and including all the critical components on a single board that can be easily connected into any existing converter.

A complete block diagram of the circuit is given in Figure 1.

For more information on EPC's family of eGaN FETs, please refer to the datasheets available from EPC at www.epc-co.com. The data-sheet should be read in conjunction with this quick start guide

Table 1: Performance Summary (TA = 25°C)

SYMBOL	PARAMETER	CONDITIONS	MIN	MAX	UNITS
V _{DD}	Gate Drive Input Supply Range		4.5	5	V
V _{IN}	Bus Input Voltage Range	When using 30 V rated EPC9201		20*	V
		When using 80 V rated EPC9203		60*	V
V _{OUT}	Switch Node Output Voltage	When using 30 V rated EPC9201		30	V
		When using 80 V rated EPC9203		80	V
I _{OUT}	Switch Node Output Current	When using 30 V rated EPC9201		40*	A
		When using 80 V rated EPC9203		20*	A
V _{PWM}	PWM Logic Input Voltage Threshold	Input 'High'	3.5	6	V
		Input 'Low'	0	1.5	V
	Minimum 'High' State Input Pulse Width	V _{PWM} rise and fall time < 10ns	60		ns
	Minimum 'Low' State Input Pulse Width	V _{PWM} rise and fall time < 10ns	200 #		ns

* Assumes inductive load, maximum current depends on die temperature – actual maximum current will be subject to switching frequency, bus voltage and thermals.

Limited by time needed to 'refresh' high side bootstrap supply voltage.

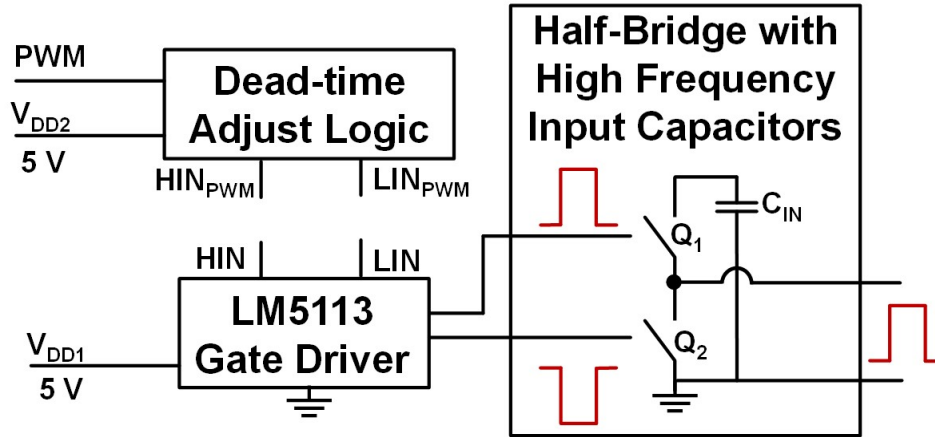

Figure 1: Block Diagram of Development Board

THERMAL CONSIDERATIONS

The development board is intended for bench evaluation with low ambient temperature and convection cooling. The addition of heat-sinking and forced air cooling can significantly increase the current rating of these devices, but care must be taken to not exceed the absolute maximum die temperature of 150°C.

NOTE. The development board does not have any current or thermal protection on board.

SINGLE PWM INPUT SETUP

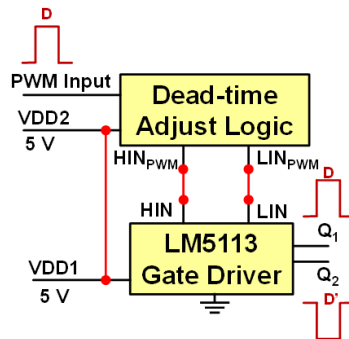

Bump Side View

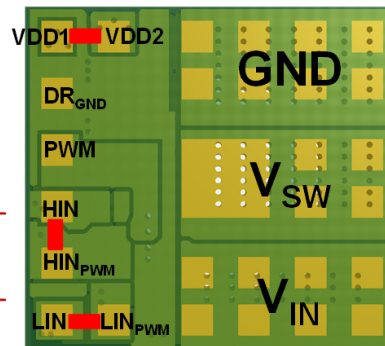
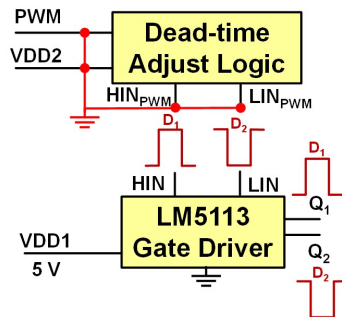

Figure 2: Single PWM input setup

TWO PWM INPUT SETUP



Bump Side View

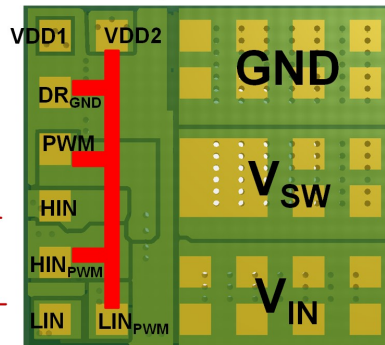

Figure 3: Two PWM input setup

TYPICAL PERFORMANCE

EPC9201

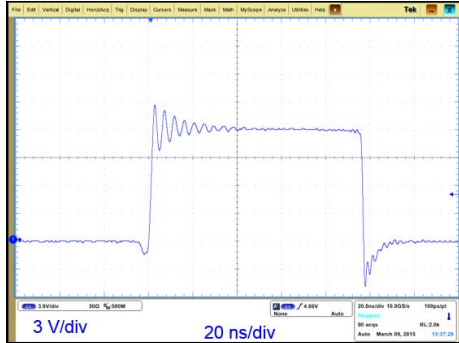

Figure 4: Typical switch node voltage waveform for $V_{IN} = 12\text{ V}$ to $V_{OUT} = 1\text{ V}$, $I_{OUT} = -40\text{ A}$, $f_{sw} = 1\text{ MHz}$ buck converter

EPC9203

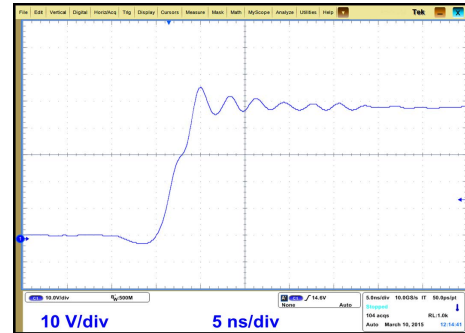

Figure 5: Typical switch node voltage waveform for $V_{IN} = 48\text{ V}$ to $V_{OUT} = 12\text{ V}$, $I_{OUT} = -20\text{ A}$, $f_{sw} = 500\text{ kHz}$ buck converter

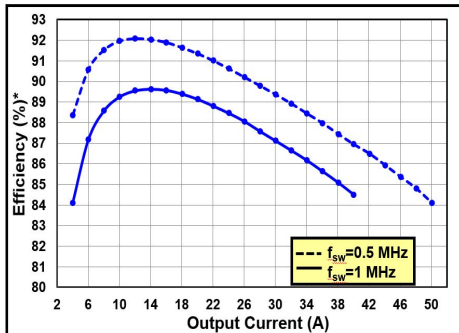

Figure 6: Typical efficiency for $V_{IN} = 12\text{ V}$ to $V_{OUT} = 1\text{ V}$, $L = 250\text{ nH}$

*Total system efficiency including power stage, inductor, driver, capacitors, and PCB losses

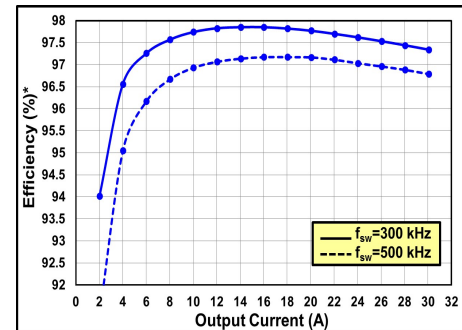

Figure 7: Typical efficiency for $V_{IN} = 48\text{ V}$ to $V_{OUT} = 12\text{ V}$, $L = 4.7\text{ }\mu\text{H}$

*Total system efficiency including power stage, inductor, driver, capacitors, and PCB losses

To improve the electrical and thermal performance of the DrGaN^{PLUS} development board some design considerations are recommended:

1. Large copper planes should be connected to the development board to improve thermal performance as shown in figures 8 through 11. If filled vias are used in the board design, thermal vias should be placed under the device as shown in figure 8 to better distribute heat through buried inner layers. For a design without filled vias, thermal vias should be located outside of the pads on the development board.
2. To reduce conduction losses, the inductor and output capacitors should be located in close proximity to the development board.
3. The smaller IC ground connection (pin 6 in mechanical drawings), should be isolated from the power ground connection (pin 3 in mechanical drawings).
4. If additional input filter capacitance is required, it can be placed outside the module. Due to the internal on-board input capacitance, minimizing the distance of the additional input capacitors to the development board, while preferred, is not a design requirement.

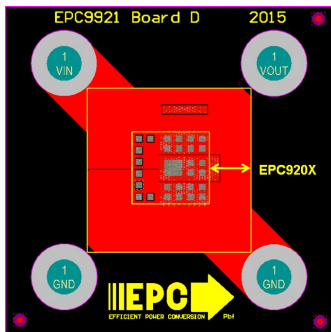

Figure 8: Top layer without filled thermal vias

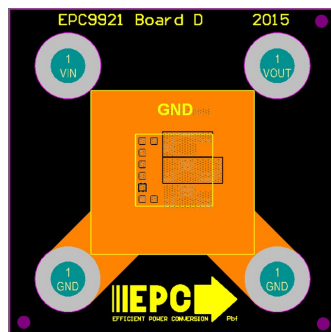

Figure 9: Inner layer 1 layout

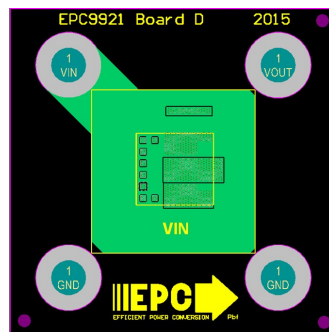

Figure 10: Inner layer 2 layout

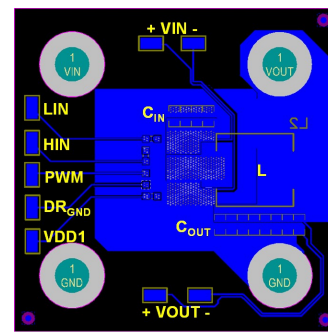
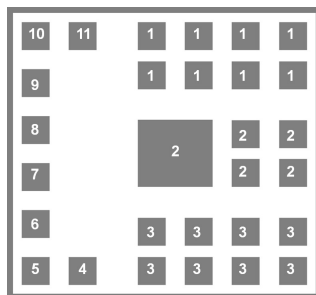
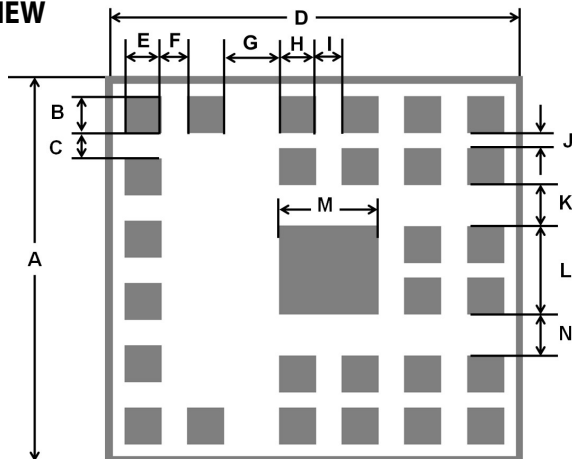

Figure 11: Bottom layer layout

MECHANICAL DATA

TOP SIDE VIEW



- Pin 1: Input Voltage, V_{IN}
- Pin 2: Switching Node, V_{SW}
- Pin 3: Power Ground, P_{GND}
- Pin 4: Driver Voltage, V_{DD2}
- Pin 5: Driver Voltage, V_{DD1}
- Pin 6: Driver Ground, DR_{GND}
- Pin 7: PWM Input, PWM
- Pin 8: High Side Input, HIN
- Pin 9: PWM High Side Input, HIN_{PWM}
- Pin 10: Low Side Input, LIN
- Pin 11: PWM Low Side Input, LIN_{PWM}

A	11 mm
B	1 mm
C	0.8 mm
D	12 mm
E	1 mm
F	0.8 mm
G	1.65 mm
H	1 mm
I	0.8 mm
J	0.5 mm
K	1.25 mm
L	2.5 mm
M	2.8 mm
N	1.25 mm

Table 2 : Bill of Materials

Item	Board Qty	Designator	Part Description	Manufacturer / Part #
1	3	CIN1, CIN2, CIN3	Capacitor, 4.7uF, 10%, 50V, X5R, 0805 (EPC9201) Capacitor, 1uF, 20%, 100V, X7S, 0805 (EPC9203)	TDK, C2012X5R1H475K125AB TDK, C2012X7S2A105M125AB
2	2	Q1, Q2	EPC9201: 40 V 33 A eGaN FET / 30 V 60 A eGaN FET EPC9203: 80 V 60 A eGaN FET	EPC, EPC2015C / EPC2023 EPC, EPC2021
3	4	R19, R20, R23, R24	Resistor, 0 Ohm, 1/16W	Stackpole, RMCF0402ZT0R00TR
4	1	C9	Capacitor, 0.1uF, 10%, 25V, X5R	TDK, C1005X5R1E104K050BC
5	1	C19	Capacitor, 1uF, 10%, 16V, X5R	TDK, C1005X5R1C105K050BC
6	1	U2	I.C., Gate driver	Texas Instruments, LM5113
7	2	D1, D2	Diode Schottky 40 V 0.12A SOD882	NXP, BAS40L,315
8	1	U4	IC GATE AND UHS 2-INP 6-MICROPAK	Fairchild, NC7SZ08L6X
9	1	U1	IC GATE NAND UHS 2-INP 6MICROPAK	Fairchild, NC7SZ00L6X
10	1	R1	Resistor, 10K Ohm 1/20W 1% 0201	Stackpole, RMCF0201FT10K0
11	2	C6, C7	Capacitor, CER 100pF 50V 5% NP0 0402	Murata, GRM1555C1H101JA01D
12	1	D3	Schottky Diode, 30V, 2A MICROSMP (EPC9201 only)	Vishay, MSS2P3-M3/89A
13	1	R4	Resistor, 3.92 OHM 1/16W 1% 0402 SMD	Stackpole, RMCF0402FT3R92
14	1	R5	Resistor, 20 Ohm 1/16W 1% 0402 SMD (EPC9201) Resistor, 100 Ohm 1/16W 1% 0402 SMD (EPC9203)	Stackpole, RMCF0402FT20R0CT Stackpole, RMCF0402FT100RCT

