

RECOMMENDED METAL MASK  
OPENING PATTERN

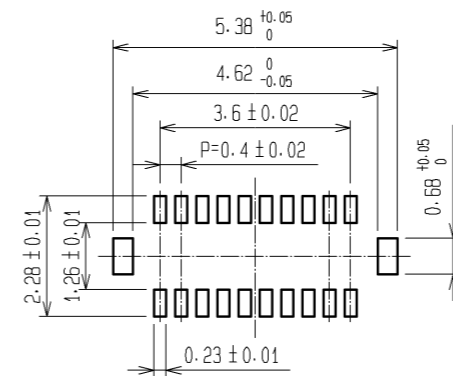

RECOMMENDED SOLDER PASTE THICKNESS: 120µm

RECOMMENDED PATTERN

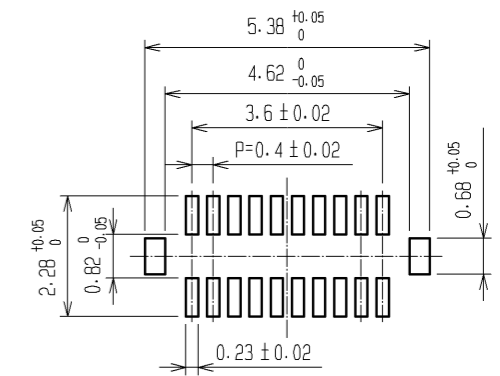

ENGAGEMENT FIGURE

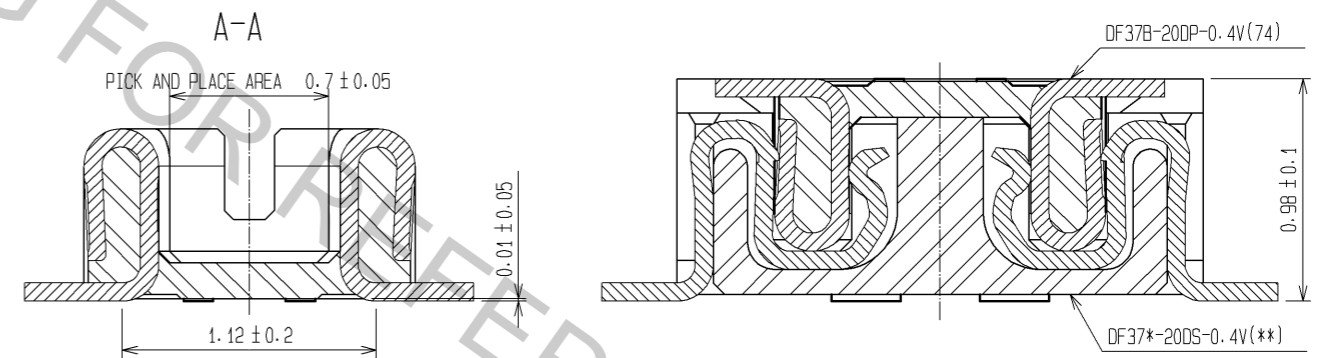

- NOTE 1. ALL LEADS CO-PLANARITY SHALL BE 0.1 mm MAX.  
 2. PER REEL : 1000 CONNECTORS.  
 3. AT THE BEGINNING OF THE REEL, 100 mm AT MIN SHALL BE EMPTY POCKETS.  
 AT THE END OF THE REEL, 160 mm AT MIN SHALL BE EMPTY.  
 4. CONTACT PLATING SPECIFICATIONS.  
 CONTACT AREA : GOLD 0.1µm MIN.  
 SMT LEAD : GOLD 0.05µm MIN.  
 UNDERPLATING : NICKEL 1µm MIN.  
 (SURFACE : SEALING)  
 5. METAL HOLD DOWN PLATING SPECIFICATIONS.  
 MOUNTING AREA: GOLD 0.05µm MIN.  
 UNDERPLATING : NICKEL 1µm MIN.  
 6. PEEL FORCE OF COVER TAPE REFERS TO JIS C 0806.

3	PHOSPHOR BRONZE	5	6	PS	PLASTIC REEL (BLACK)
2	PHOSPHOR BRONZE	4	5	POLYESTER	CLEAR(COVER TAPE)
1	LCP	UL94V-0, BLACK	4	PS	CLEAR(EMBOSSED CARRIER TAPE)
NO.	MATERIAL	FINISH, REMARKS	NO.	MATERIAL	FINISH, REMARKS
UNITS mm		SCALE FREE	COUNT 	DESCRIPTION OF REVISIONS	
APPROVED : KH. IKEDA		09.02.06	DRAWING NO. EDC3-308583-04		
CHECED : TS. MIYAZAKI		09.02.06	PART NO. DF37B-20DP-0.4V(74)		
DESIGNED : RT. SHIMIZU		09.02.06	CODE NO. CL684-3008-1-74		
DRAWN : AK. AOYAGI		09.02.06	DATE		

Apr.1.2017 Copyright 2017 HIROSE ELECTRIC CO., LTD. All Rights Reserved.

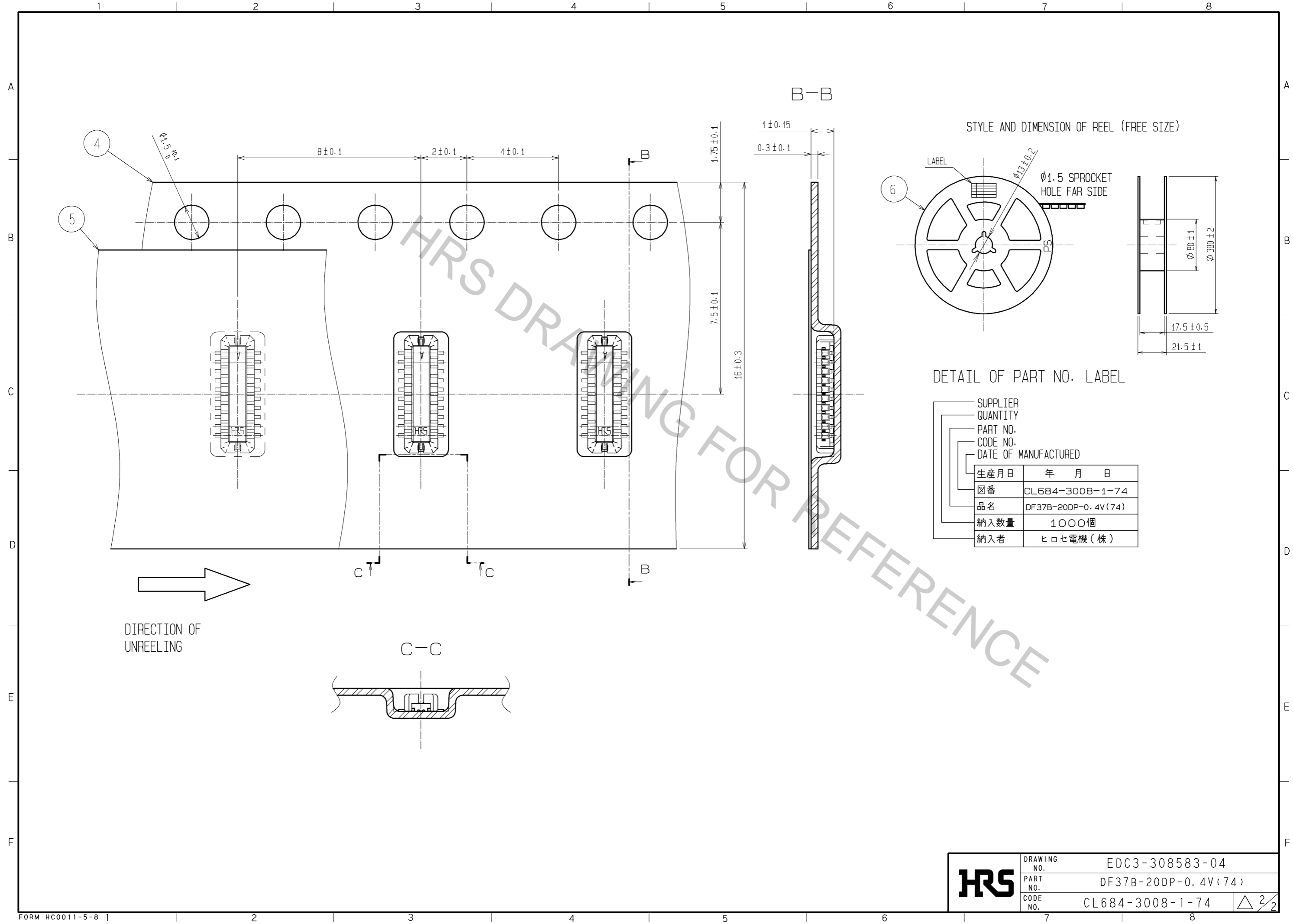

<b>HRS</b>	DRAWING NO.	EDC3-308583-04
	PART NO.	DF37B-20DP-0.4V(74)
	CODE NO.	CL684-3008-1-74
		△ 2/2