

REVISION AD

DO NOT SCALE FROM THIS PRINT

		TABLE 1			MATED HEIGHT WITH QSH-01-DP	
STYLE	"A"	"B"	BODY	GROUND PLANE	TERMINAL	
-01	.1680[4.267]	.1600[4.064]	QTH-30-01-D-XX	T-1G1-01-X	T-1S39-01-X	.197[5.00] REF
-02	.2861[7.267]	.2781[7.064]	QTH-30-02-D-XX	T-1G1-02-X	T-1S59-02-X	.315[8.00] REF

TABLE 2	
No OF POSITIONS	COPLANARITY (INCLUDING GP)
-020 THRU -060	.004 [0.10]
-080 & -100	.006 [0.15]

TABLE 3		
No OF POS	"D"	"E"
-020	.788 [20.00]	.728 [18.48]
-040	1.575 [40.01]	1.515 [38.48]
-060	2.363 [60.01]	2.303 [58.48]
-080	3.150 [80.01]	3.090 [78.49]
-100	3.938 [100.01]	3.878 [98.49]

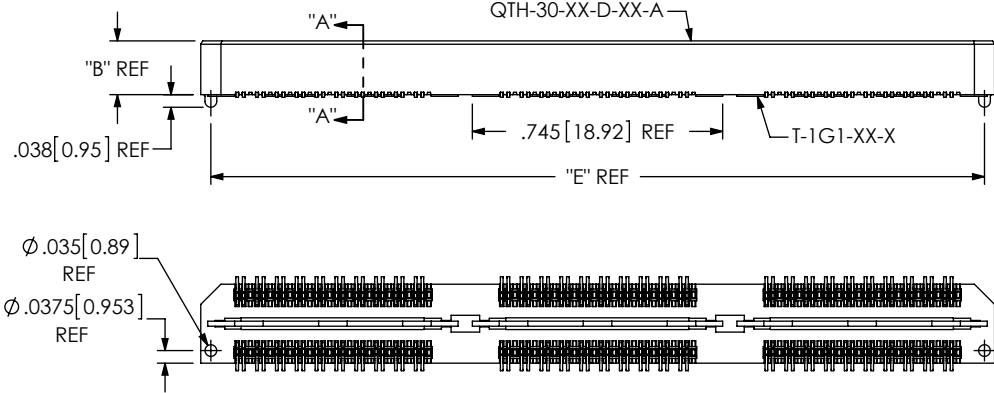
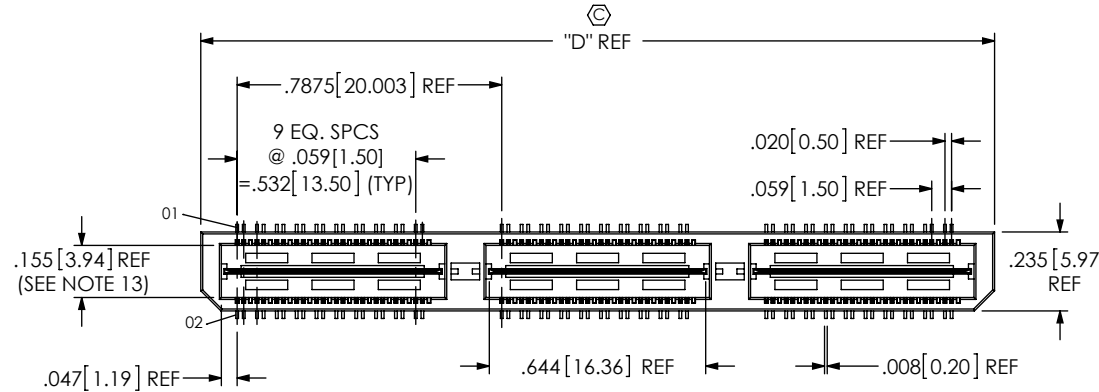

- NOTES:
1. © REPRESENTS A CRITICAL DIMENSION.
  2. MINIMUM PUSHOUT FORCE: 6 OZ FOR -01 & -02, 8 OZ FOR -03 THRU -09.
  3. MINIMUM GROUND PLANE RETENTION: 1 LB.
  4. PARTS TO BE MOLDED TO POSITION.
  5. MAXIMUM VARIANCE OF .002[0.05]. APPLIES TO SIGNAL OR GROUNDS INDEPENDENT OF THE GROUND OR SIGNAL PINS RESPECTIVELY.
  6. LEAD STYLES -03 THRU -08: TOP BODY (QTH) CANNOT HAVE -A OPTION.
  7. -L PLATING CAN BE SUBSTITUTED FOR -F PLATING.
  8. GROUND PLANE PRESS HEIGHT MUST BE .003 [0.08] LESS THAN THE MAXIMUM HEIGHT OR .002[0.03] GREATER THAN THE MINIMUM HEIGHT OF SIGNAL PIN.
  9. T-1R36 RETENTION TO BODY TO BE 1.0 LBF.
  10. CUT OFF BURR NOT TO EXCEED .003[0.08] IN ANY DIRECTION, BURR PLUS TAB HEIGHT NOT TO EXCEED .006[0.15].
  11. FOR NEW APPLICATIONS REQUIRING THESE POSITIONS, PLEASE CONTACT SAMTEC INTERCONNECT PROCESSING GROUP.
  12. DUE TO THE HIGH AMOUNT OF INSERTION FORCE NEEDED, THE -LC OPTION IS NOT COMPATIBLE WITH AUTO PLACEMENT. SAMTEC RECOMMENDS MANUAL PLACEMENT FOR ALL ASSEMBLIES WITH THE -LC OPTION.
  13. PIN CAN EXTEND PAST WALL .003[0.08] MAX.

FIG 1  
-A: ALIGNMENT PIN OPTION (QTH-060-01-X-D-A SHOWN) (FOR -01 & -02 LEAD STYLE ONLY)

QTH-XXX-XX-X-D-DP-XXX

- No OF POSITIONS (PER ROW) \*\*\*SEE NOTE 11
- LEAD STYLE
- \*-01: .1680[4.267]
  - \*-02: .2861[7.264]
  - \*-03: .4042[10.267]
  - \*-04: .6001[15.243]
  - \*-05: .7181[18.240]
  - \*-06: .8361[21.237]
  - \*-07: .9542[24.237]
  - \*-08: 1.1511[29.238]
  - \*-09: .5224[13.269]
  - \*-10: .5618[14.270]
- OPTION
- A: ALIGNMENT PINS (SEE FIGS 1 & 3, SHT 2)
  - LC: LOCKING CLIPS (USE LC-08-TM-01, SEE FIG 2) (SEE NOTE 12)
  - K: POLYIMIDE FILM (USE K-500-300) (AVAILABLE ON -01 THRU -04 & -09 AND -10 ONLY) (SEE FIG 4, SHT 2)
  - TR: TAPE & REEL (60 POS MAX) (40 POS MAX FOR -GP OPTION)
  - \*\* -GP: GUIDE POSTS OPTION (AVAILABLE ON -01 & \*-02 ONLY) (USE QTH-30-XX-D-XX-GP) (SEE FIG 8, SHT 4)
  - RT1: RETENTION OPTION (SEE FIG 9, SHT 4) (ONLY AVAILABLE ON -01 LEAD STYLE) (MUST USE -A OPTION) (USE QTH-30-01-D-XX-A-RT1 & T-1R36-01-F) (NOT AVAILABLE WITH -LC OR -GP) (NOT AVAILABLE ON -080 & -100 POS)
  - L: LATCHING OPTION (SEE FIG 10, SHT 5) (ONLY AVAILABLE ON -01 LEAD STYLE) (USE QTH-30-01-D-XX-L) (NOT AVAILABLE WITH -LC, -GP, -FL, OR -RT1) (40 POS MAX)
  - FL: FRICTION LOCKS (SEE FIG 11, SHT 5) (NOT AVAILABLE WITH -GP)
- PLATING SPECIFICATION
- F: 3µ" SELECTIVE GOLD IN CONTACT AREA, MATTE TIN ON TAIL (USE T-1GXX-XX-F) (SEE NOTE 7)
  - L: 10µ" SELECTIVE GOLD IN CONTACT AREA, MATTE TIN ON TAIL (USE T-1GXX-XX-L)
  - H: 30µ" GOLD IN CONTACT AREA, 3µ" GOLD ON TAIL (USE T-1GXX-XX-G)
  - C: 50µ" ELECTRO-POLISHED SELECTIVE IN CONTACT AREA, MATTE TIN ON TAIL (USE T-1GXX-XX-L)
- \* = RELEASED FOR ASO ONLY (APPLICATION SPECIFIC ORDER)  
\*\* = -02 LEAD STYLE NOT RELEASED FOR PRODUCTION
- DIFFERENTIAL PAIRS
- ROW SPECIFICATION
- D: DOUBLE (USE QTH-30-01-D-XX)
- No OF BANKS

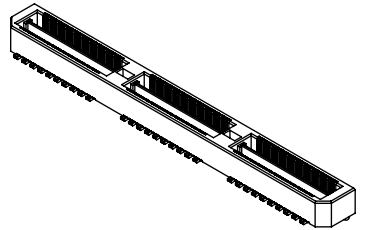
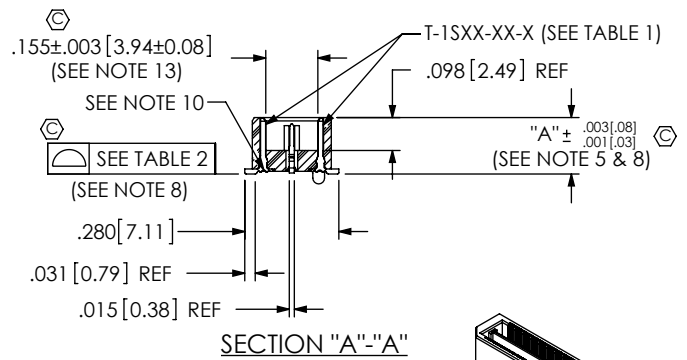

UNLESS OTHERWISE SPECIFIED, DIMENSIONS ARE IN INCHES. TOLERANCES ARE: DECIMALS ANGLES .XX: ±.01[.3] .XXX: ±.005[.13] .XXXX: ±.0020[.051]	PROPRIETARY NOTE THIS DOCUMENT CONTAINS CONFIDENTIAL AND PROPRIETARY INFORMATION AND ALL DESIGN, MANUFACTURING, REPRODUCTION, USE, PATENT RIGHTS AND SALES RIGHTS ARE EXPRESSLY RESERVED BY SAMTEC, INC. THIS DOCUMENT SHALL NOT BE DISCLOSED, IN WHOLE OR PART, TO ANY UNAUTHORIZED PERSON OR ENTITY NOR REPRODUCED, TRANSFERRED OR INCORPORATED IN ANY OTHER PROJECT IN ANY MANNER WITHOUT THE EXPRESS WRITTEN CONSENT OF SAMTEC, INC.	520 PARK EAST BLVD, NEW ALBANY, IN 47150 PHONE: 812-944-6733 FAX: 812-948-5047 e-Mail info@SAMTEC.com code 55322



**FIG 2**  
 -LC: LOCKING CLIP OPTION  
 (QTH-060-01-X-D-LC SHOWN)  
 (DIFFERENT AS SHOWN, OTHERWISE SAME AS FIG 1)

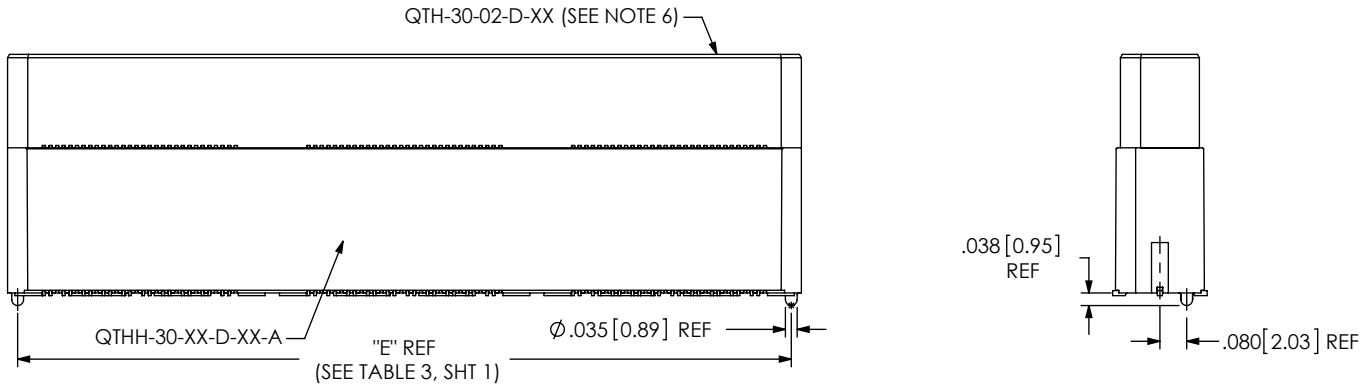

**FIG 3**  
 -A: ALIGNMENT PIN OPTION  
 (QTH-060-05-X-D-DP-A SHOWN)  
 (FOR -03 THRU -08 LEAD STYLE ONLY)  
 (SEE TABLE 4, SHT 3)  
 (DIFFERENT AS SHOWN, OTHERWISE SAME AS FIG 1)

No OF POS	"R"				"S"			
	-A, -LC, -FL	-GP	-RT1	-L	-A, -LC, -FL	-GP	-RT1	-L
-020	.788 [20.00]	1.305 [33.15]	1.438 [36.53]	.906 [23.00]	.256 [6.50]	.515 [13.07]	.581 [14.76]	.315 [7.99]
-040	1.575 [40.01]	2.093 [53.15]	2.226 [56.53]	1.693 [43.00]	.650 [16.50]	.908 [23.07]	.975 [24.76]	.709 [18.00]
-060	2.363 [60.01]	2.880 [73.15]	3.013 [76.53]	2.481 [63.00]	1.043 [26.50]	1.302 [33.07]	1.369 [34.76]	1.103 [28.00]
-080	3.150 [80.01]	3.668 [93.15]	N/A	N/A	1.437 [36.50]	1.696 [43.07]	N/A	N/A
-100	3.938 [100.01]	4.455 [113.16]	N/A	N/A	1.831 [46.50]	2.090 [53.07]	N/A	N/A

STYLE	"T"
-01	.173[4.39]
-02	.291[7.39]
-03	.409[10.39]
-04	.605[15.37]
-09	.527[13.39]
-10	.566[14.39]

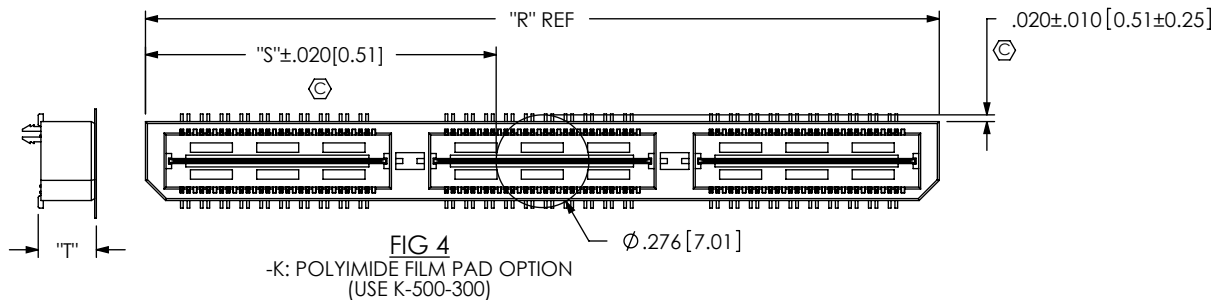

**FIG 4**  
 -K: POLYIMIDE FILM PAD OPTION  
 (USE K-500-300)

**PROPRIETARY NOTE**  
 THIS DOCUMENT CONTAINS CONFIDENTIAL AND PROPRIETARY INFORMATION AND ALL DESIGN, MANUFACTURING, REPRODUCTION, USE, PATENT RIGHTS AND SALES RIGHTS ARE EXPRESSLY RESERVED BY SAMTEC, INC. THIS DOCUMENT SHALL NOT BE DISCLOSED, IN WHOLE OR PART, TO ANY UNAUTHORIZED PERSON OR ENTITY NOR REPRODUCED, TRANSFERRED OR INCORPORATED IN ANY OTHER PROJECT IN ANY MANNER WITHOUT THE EXPRESS WRITTEN CONSENT OF SAMTEC, INC.

DO NOT SCALE DRAWING  
 SHEET SCALE: 1:75:1



520 PARK EAST BLVD, NEW ALBANY, IN 47150  
 PHONE: 812-944-6733 FAX: 812-948-5047  
 e-Mail: info@SAMTEC.com code 55322

DESCRIPTION:  
 .5mm DIFFERENTIAL PAIRS TERMINAL ASSEMBLY  
 DWG. NO.  
**QTH-XXX-XX-X-D-DP-XXX**  
 BY: KEVIN B 09-14-2010 SHEET 2 OF 5

REVISION AD

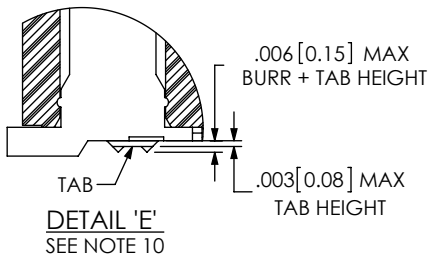

STYLE	SEE FIGURE	"C" OVERALL HEIGHT	GROUND PLANE	TERMINAL	TOP BODY (SEE NOTE 6)	BOTTOM SPACER BODY (-LC OR NONE)	BOTTOM SPACER BODY (-A)	MATED HEIGHT WITH QSH-01
-03	5	.4043 [10.269]	T-1G1-03-X	T-1S60-03-X	QTH-30-02-D-XX	QTHH-30-01-D-XX	QTHH-30-01-D-XX-A	.433 [11.00] REF
-04	5	.6001 [15.243]	T-1G1-04-X	T-1S60-04-X	QTH-30-02-D-XX	QTHH-30-01-D-XX	QTHH-30-01-D-XX-A	.630 [16.00] REF
-05	6	.7181 [18.240]	T-1G1-05-X	T-1S60-05-X	QTH-30-02-D-XX	QTHH-30-03-D-XX	QTHH-30-03-D-XX-A	.748 [19.00] REF
-06	6	.8361 [21.237]	T-1G1-06-X	T-1S60-06-X	QTH-30-02-D-XX	QTHH-30-03-D-XX	QTHH-30-03-D-XX-A	.866 [22.00] REF
-07	7	.9542 [24.237]	T-1G1-07-X	T-1S61-21-X	QTH-30-02-D-XX	QTHH-30-04-D-XX	QTHH-30-04-D-XX-A	.984 [24.99] REF
-08	7	1.1511 [29.238]	T-1G1-07-X	T-1S61-22-X	QTH-30-02-D-XX	QTHH-30-04-D-XX	QTHH-30-04-D-XX-A	1.181 [30.00] REF
-09	5	.5224 [13.269]	T-1G1-09-X	T-1S60-09-X	QTH-30-02-D-XX	QTHH-30-01-D-XX	QTHH-30-01-D-XX-A	.551 [14.00] REF
-10	5	.5618 [14.270]	T-1G1-10-X	T-1S60-10-X	QTH-30-02-D-XX	QTHH-30-01-D-XX	QTHH-30-01-D-XX-A	.591 [15.01] REF

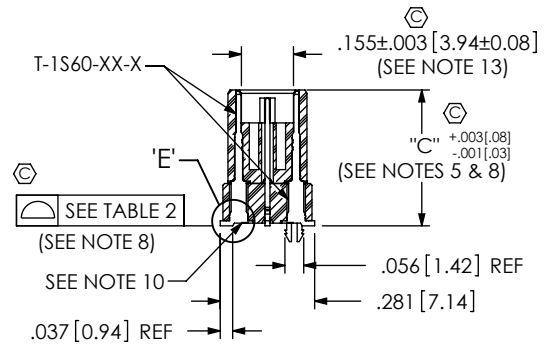
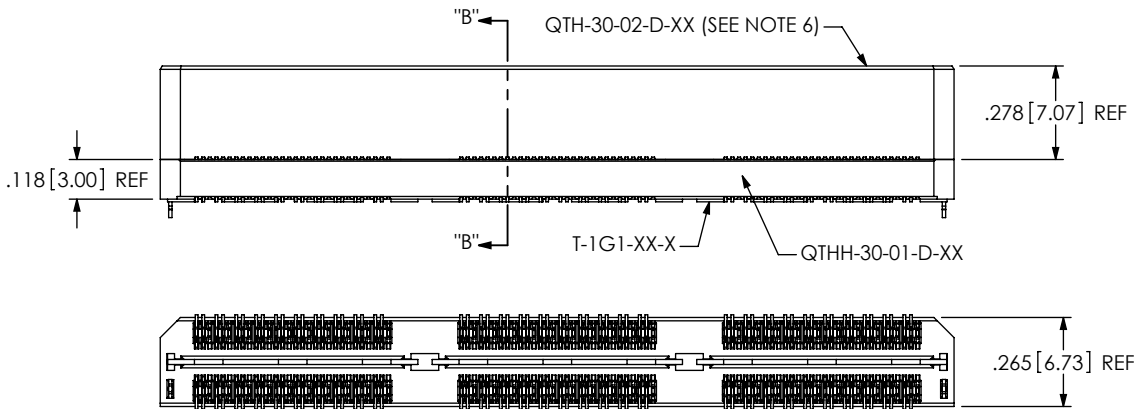

FIG 5  
QTH-060-03-X-D-DP-LC SHOWN  
(DIFFERENT AS SHOWN, OTHERWISE SAME AS FIG 1)

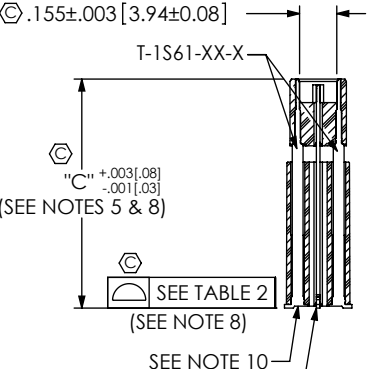
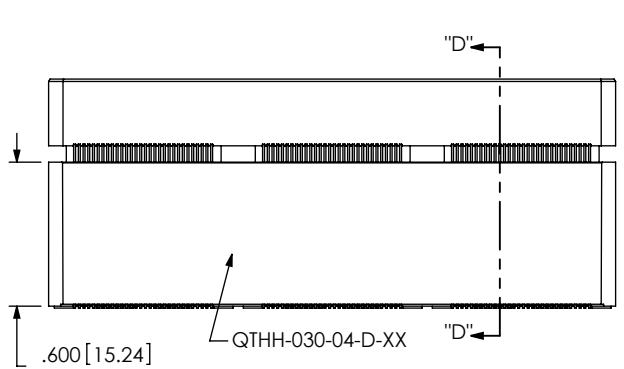
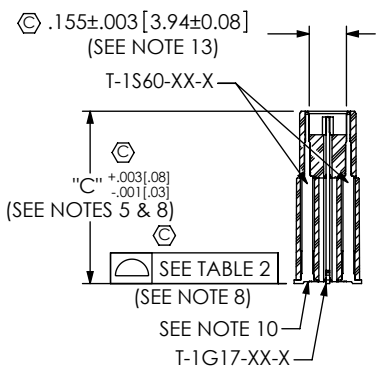
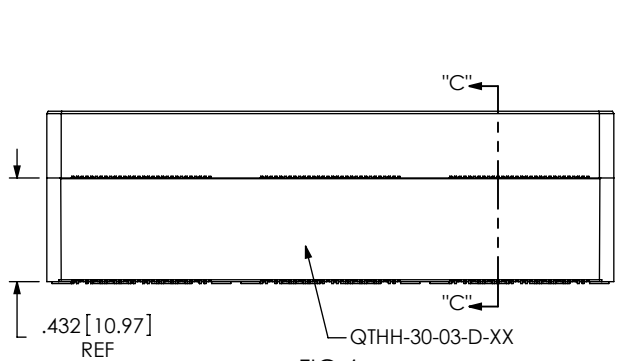

FIG 7  
QTH-060-07-X-D-DP SHOWN  
(DIFFERENT AS SHOWN, OTHERWISE SAME AS FIG 3)

**PROPRIETARY NOTE**  
THIS DOCUMENT CONTAINS CONFIDENTIAL AND PROPRIETARY INFORMATION AND ALL DESIGN, MANUFACTURING, REPRODUCTION, USE, PATENT RIGHTS AND SALES RIGHTS ARE EXPRESSLY RESERVED BY SAMTEC, INC. THIS DOCUMENT SHALL NOT BE DISCLOSED, IN WHOLE OR PART, TO ANY UNAUTHORIZED PERSON OR ENTITY NOR REPRODUCED, TRANSFERRED OR INCORPORATED IN ANY OTHER PROJECT IN ANY MANNER WITHOUT THE EXPRESS WRITTEN CONSENT OF SAMTEC, INC.

**samtec**  
520 PARK EAST BLVD. NEW ALBANY, IN 47150  
PHONE: 812-944-6733 FAX: 812-948-5047  
e-Mail: info@SAMTEC.com code 55322

DO NOT SCALE DRAWING  
SHEET SCALE: 1:75:1

DESCRIPTION:  
.5mm DIFFERENTIAL PAIRS TERMINAL ASSEMBLY  
DWG. NO.  
**QTH-XXX-XX-X-D-DP-XXX**  
BY: KEVIN B 09-14-2010 SHEET 3 OF 5

TABLE 8		
No OF POS	"G"	"H"
-020	1.305 [33.15]	1.013 [25.73]
-040	2.093 [53.15]	1.801 [45.73]
-060	2.880 [73.15]	2.588 [65.74]
-080	3.668 [93.15]	3.376 [85.74]
-100	4.455 [113.16]	4.163 [105.74]

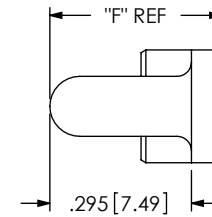
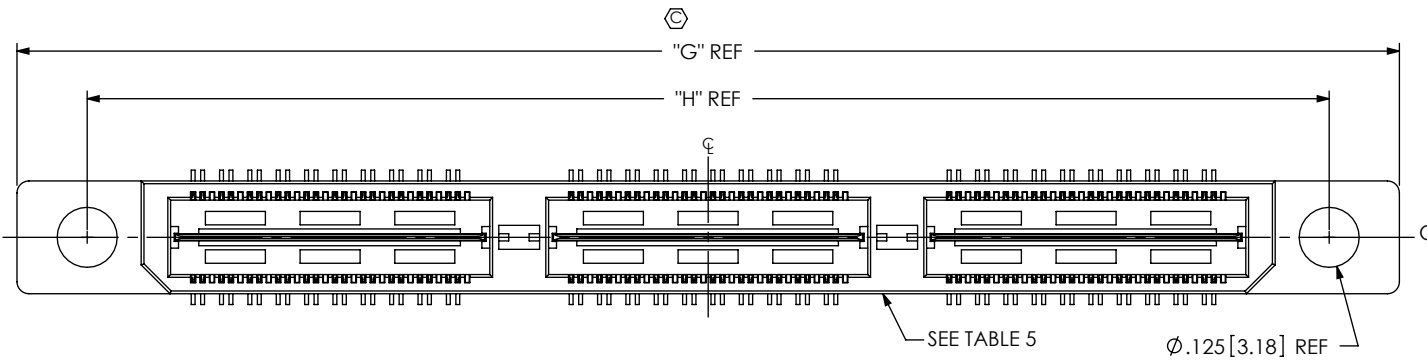

**FIG 8**  
 -GP: GUIDE POST OPTION  
 (QTH-060-01-X-D-DP-GP SHOWN)  
 (FOR -01 & -02 LEAD STYLE ONLY)  
 (DIFFERENT AS SHOWN, OTHERWISE SAME AS FIG 1)

TABLE 7		
STYLE	"F"	BODY
-01	.3630[9.220]	QTH-30-01-D-XX-X-GP
*-02	.4811[12.220]	QTH-30-02-D-XX-X-GP

(\* = NOT ENGINEERING APPROVED)

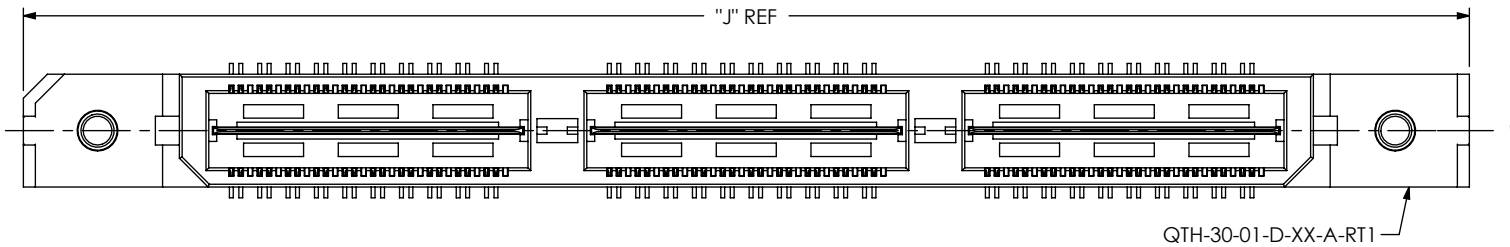
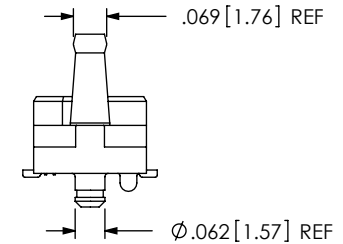
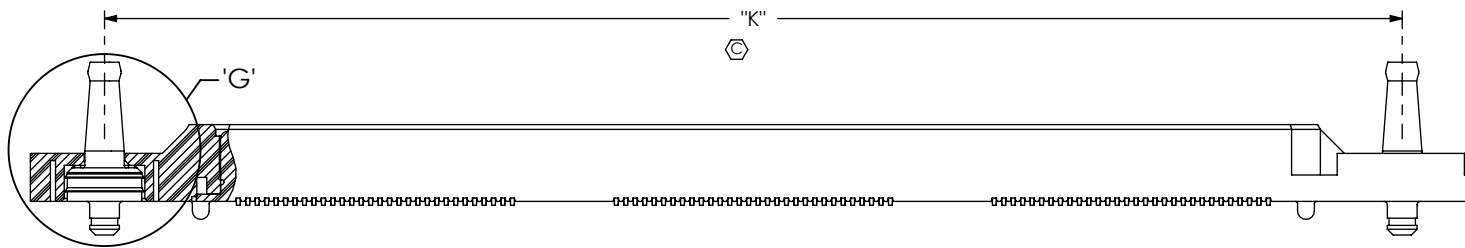
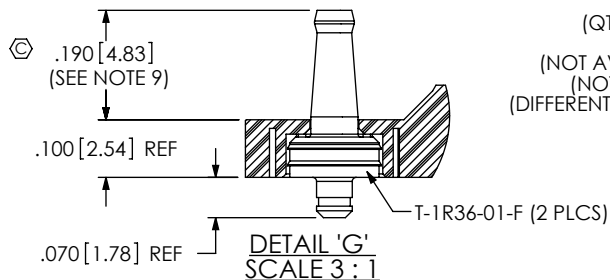

TABLE 9		
No OF POS	"J"	"K"
-020	1.438 [36.53]	1.129 [28.68]
-040	2.226 [56.53]	1.917 [48.68]
-060	3.013 [76.53]	2.704 [68.68]
-080	N/A	N/A
-100	N/A	N/A



F:\DWG\MISC\MKTG\QTH-XXX-XX-X-D-DP-XXX-MKT.SLDDRW

**FIG 9**  
 -RT1: RETENTION OPTION  
 (QTH-060-01-X-D-DP-A-RT1 SHOWN)  
 (FOR -01 LEAD STYLE ONLY)  
 (NOT AVAILABLE WITH -LC OR -GP OPTIONS)  
 (NOT AVAILABLE ON -080 & -100 POS)  
 (DIFFERENT AS SHOWN, OTHERWISE SAME AS FIG 1)



**PROPRIETARY NOTE**  
 THIS DOCUMENT CONTAINS CONFIDENTIAL AND PROPRIETARY INFORMATION AND ALL DESIGN, MANUFACTURING, REPRODUCTION, USE, PATENT RIGHTS AND SALES RIGHTS ARE EXPRESSLY RESERVED BY SAMTEC, INC. THIS DOCUMENT SHALL NOT BE DISCLOSED, IN WHOLE OR PART, TO ANY UNAUTHORIZED PERSON OR ENTITY NOR REPRODUCED, TRANSFERRED OR INCORPORATED IN ANY OTHER PROJECT IN ANY MANNER WITHOUT THE EXPRESS WRITTEN CONSENT OF SAMTEC, INC.

DO NOT SCALE DRAWING  
 SHEET SCALE: 2.5:1



520 PARK EAST BLVD, NEW ALBANY, IN 47150  
 PHONE: 812-944-6733 FAX: 812-948-5047  
 e-Mail: info@SAMTEC.com code 55322

DESCRIPTION:  
 .5mm DIFFERENTIAL PAIRS TERMINAL ASSEMBLY

DWG. NO.  
**QTH-XXX-XX-X-D-DP-XXX**

BY: KEVIN B 09-14-2010 SHEET 4 OF 5

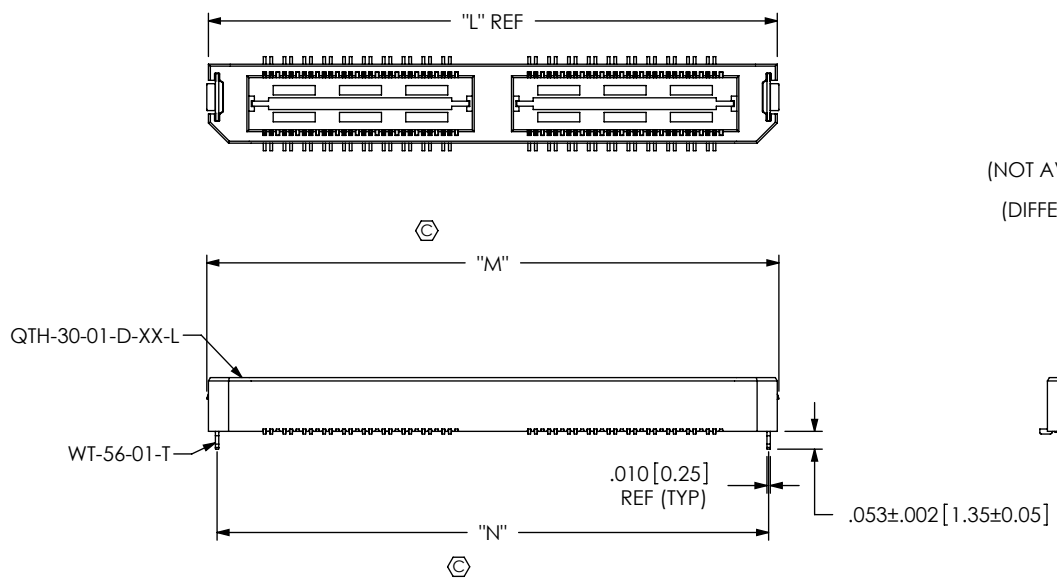
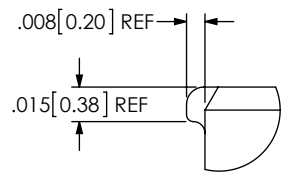
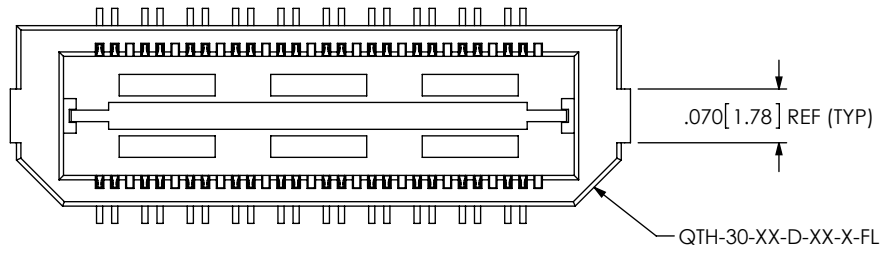

**FIG 10**  
 -L: LATCHING OPTION  
 (QTH-040-01-X-DP-L SHOWN)  
 (AVAILABLE ON -01 LEAD STYLE ONLY)  
 (NOT AVAILABLE WITH -LC, -GP, -FL, OR -RT1 OPTIONS)  
 (40 POS MAX)  
 (DIFFERENT AS SHOWN, OTHERWISE SAME AS FIG 1)

**TABLE 10**

No OF POS	"L"	"M"	"N"
-020	.906 [23.01]	.915 [23.24]	.854 [21.69]
-040	1.694 [43.01]	1.703 [43.24]	1.642 [41.69]
*-060	2.481 [63.02]	2.490 [63.25]	2.429 [61.70]
-080	N/A	N/A	N/A
-100	N/A	N/A	N/A

\* = NOT RELEASED



**DETAIL 'H'**  
 SCALE 12 : 1

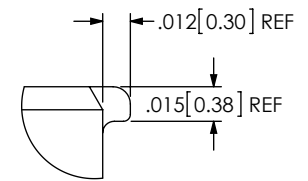

**DETAIL 'J'**  
 SCALE 12 : 1

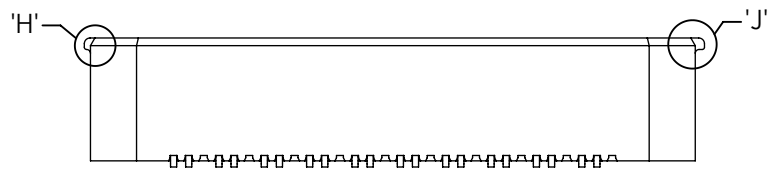

**FIG 11**  
 -FL: FRICTION LOCKS  
 (NOT AVAILABLE WITH -GP OPTION)  
 (DIFFERENT AS SHOWN, OTHERWISE SAME AS FIG 1)

**PROPRIETARY NOTE**  
 THIS DOCUMENT CONTAINS CONFIDENTIAL AND PROPRIETARY INFORMATION AND ALL DESIGN, MANUFACTURING, REPRODUCTION, USE, PATENT RIGHTS AND SALES RIGHTS ARE EXPRESSLY RESERVED BY SAMTEC, INC. THIS DOCUMENT SHALL NOT BE DISCLOSED, IN WHOLE OR PART, TO ANY UNAUTHORIZED PERSON OR ENTITY NOR REPRODUCED, TRANSFERRED OR INCORPORATED IN ANY OTHER PROJECT IN ANY MANNER WITHOUT THE EXPRESS WRITTEN CONSENT OF SAMTEC, INC.

DO NOT SCALE DRAWING

SHEET SCALE: 2.5:1

**samtec**  
 520 PARK EAST BLVD, NEW ALBANY, IN 47150  
 PHONE: 812-944-6733 FAX: 812-948-5047  
 e-Mail info@SAMTEC.com code 55322

DESCRIPTION:  
 .5mm DIFFERENTIAL PAIRS TERMINAL ASSEMBLY

DWG. NO.  
 QTH-XXX-XX-X-D-DP-XXX

BY: KEVIN B 09-14-2010 SHEET 5 OF 5