

# Amphenol®

Introduction  
Overview (How to use the Catalog)

## Sub-Miniature

MMCX .....	6
MCX .....	17
1.0 / 2.3 .....	25
SMB .....	35
SMC .....	51
SMA .....	55
APC .....	85

## Miniature

1.6 / 5.6 .....	101
BNC .....	105
TNC .....	139
Reverse Polarity .....	149

Tools .....	159
-------------	-----

## Standard

Twinaxial .....	167
Twin BNC .....	171
Triax .....	173
UHF .....	185
Mini-UHF .....	193

## C, HN, SC

C .....	198
HN .....	200
SC .....	203

## FME

FME .....	205
Adapters- Between Series .....	209

## Wireless

Type N .....	224
Type F .....	245
Type G .....	253
7/16 .....	259

Cable Assembly Instructions .....	273
-----------------------------------	-----

Glossary .....	349
----------------	-----





# Amphenol®

## The Company

Amphenol Corporation is one of the largest manufacturers of interconnect products in the world. The company designs, manufactures and markets RF/microwave connectors; flat ribbon cable and interconnect systems; CATV cable and connectors; electronic connectors; and fiber-optic connectors. The primary end markets for Amphenol products are communications and information processing, including cable television, cellular telephone, data communications and instrumentation; aerospace and military electronics; automotive, rail and other transportation; and industrial applications.

Amphenol Corporation is a world leader in providing integrated interconnect solutions to the telecommunications industry. Recognized worldwide as a technology leader in the wireless market, Amphenol offers a full complement of RF coaxial products from MMCX connectors used on cellular subscriber units to low intermodulation 7/16 DIN connectors used on cellular base stations. Today, Amphenol is a major player in this global arena; a position founded on the combined strengths

of a broad product line and a leadership role in product innovation.

As the information super highway expands, the demand for interconnect solutions continues to grow into new and exciting areas. Amphenol is a leading producer of broadband coaxial cable, connectors and fiber optic interconnect components. Amphenol is uniquely capable of supplying the complete Hybrid Fiber/Coaxial (HFC) interconnect systems which form the backbone of the information super highway. As a result, every household, business, private and government institution is a potential customer and will depend on Amphenol's commitment to quality and product innovation.

In the area of computers and electronic data interchange, Amphenol continues to concentrate on the fastest growing segments; such as cable assemblies and line terminators which bring reliable, miniaturized solutions to LANS and other interactive communications networks, to high density connectors utilized in next generation global telecommunications switching systems.

Amphenol's ability to provide fully integrated solutions even extends into the arena of smart card technology, where microchips and sophisticated chip card acceptor devices are being combined for a growing number of applications from banking, to security, to medicine, to voice recognition systems.

Maintaining this position as a leader in the field of communications requires close interaction with a worldwide customer base through international management teams, distributed manufacturing, global quality assurance programs and sophisticated distribution networks. By remaining totally committed to the customer, Amphenol provides the very highest levels of quality and responsive service, anywhere in the world.

# Did You Know?

**UHF** - Invented in the 1930's by an Amphenol engineer, E. Clark Quackenbush, for use in the radio industry.

**N** - Was the first coaxial connector capable of microwave performance and was invented by and named for Paul Neill of Bell Labs.

**C** - Invented by and named for Amphenol engineer Carl Concelman. Type C has quick connect/disconnect bayonet coupling features.

**BNC** - A miniature version of the Type C. The name stands for **B**ayonet **N**eill **C**oncelman.

**TNC** - The name stands for **T**hreaded **N**eill **C**oncelman. This series features screw threads for mating.

**APC™** - Invented by Amphenol and Hewlett-Packard engineers. The name is an acronym for **A**mphenol **P**recision **C**onnectors.

## Amphenol RF Division

Amphenol is the world's largest manufacturer of RF connectors with experience extending over half a century. Our complete range of RF interconnect products are used in the cellular/PCS, telecommunications, computer networking and instrumentation industries. These include Standard/ Miniature connectors (UHF, Mini-UHF, N, 50 & 75 ohm BNC, and RP-BNC, Twinaxial, DIN 1.6/5.6, TNC and RP-TNC); Subminiature connectors (SMA and RP-SMA, SMB, SMC, DIN 1.0/2.3, and size 8 contacts); MicroMate™ Microminiature connectors; DIN 7116 and corrugated cable connectors. Amphenol offers a full line of semiflex and drop cable connectors to meet the demanding requirements of HFC broadband infrastructure being developed by CATV MSOs and telephone companies worldwide.

## Commitment to Customer Service

For over 60 years, leading manufacturers of communications, consumer, industrial and aerospace products have relied on Amphenol to provide total interconnect solutions.

Maintaining this high level of customer trust requires a total concern for complete customer satisfaction at all levels — from engineering, to manufacturing, to quality assurance. Since many products are custom designed to individual customer specifications, often for the harshest environments, it's critical that a teamwork approach be taken, involving the customer at all levels. It starts with the design engineers who listen closely to customer needs, combining solid analytic skills with the latest CAE and CAD tools to quickly solve problems.

Amphenol also employs multi-functional teams to ensure that all products are designed for manufacturability. Serving the needs of our customers also requires a strong worldwide manufacturing presence. That's why we operate advanced production and assembly facilities strategically located across three continents. Yet, our quality remains exceptionally uniform and internationally standardized, from raw materials testing, through design engineering, to automated manufacturing and sub-assembly, to fully documented and traceable test

procedures developed in accordance with customer specifications. Amphenol also employs Statistical Process Control and has obtained ISO 9000 Certification for all its production facilities worldwide. As a result, we offer precisely what every customer is looking for — world class quality at the lowest possible cost.

## How to Use This Catalog

### Frequency Range

The application frequency range may limit the connector choice. Refer to the inside front cover for the Frequency Range Chart.

### Cable

The cable specified may limit the connector choice. Refer to pages viii and ix for cable/connector chart.

### Impedance

For maximum impedance matching, the connector has the same impedance as the cable. Standard connector choices are 50 ohm or 75 ohm.

### Coupling Style

The application will determine the coupling mechanism preference. Basic styles: 2-Stud Bayonet, Threaded, Snap-on, and Slide-on.

### Performance Specifications

The application performance requirements may limit the connector choice. Criteria to consider: Voltage Rating, Dielectric Withstand Voltage, and Voltage Standing Wave Ratio (VSWR).

### Reviewing The Connector Choices

Refer to the Connector Selector Guide on pages vi-vii for a quick overview of each product series

### Locating The Connector Series

Refer to page i for product series listings. At the beginning of each product series is information pertaining to the connector mating face dimensions and typical characteristics regarding mechanical, material, environmental and performance of the connector design.

### Connector P/N

The connector part number is located in the far right column, opposite the appropriate cable.

### Cable

The cable listed in the first column is based on the mechanical size of military specified cable. Caution is advised when a commercial, RG Type size cable is being used since the cable dimensions may vary and result in a different size center conductor, dielectric, braiding and outer jacket of the cable. If the manufacturer's commercial cable P/N is not listed, contact Amphenol's customer service representative for the appropriate connector recommendation.

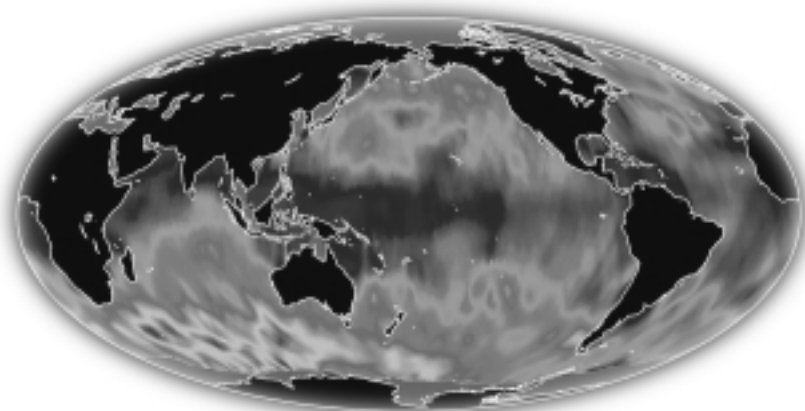

## Specific Connector Information

Each connector listed has a plating code / Plt.; insulation code / Ins.; and cable assembly instruction / CAI. Refer to page 232 for the code charts.

Example:

D1 = TFE or equivalent

P1 = Nickel plated body, silver plated contact

## Cable Assembly Instructions

If you already know the connector P/N and are looking for the assembly instructions, refer to the Connector Assembly Index on pages 240-241. The appropriate CAI code number is listed opposite the connector part number.

## Design Considerations

Typically, the shorter the cable assembly, the more critical the connector insertion loss becomes.

Typically, the longer the cable assembly, the less critical the connector insertion loss becomes.

Typically, the higher the frequency, the more critical the connector insertion loss becomes.

Typically, the more critical the connector insertion loss, the more critical the matched impedance of the cable and the connector becomes.

## Intermodulation (IM)

Intermodulation is a phenomena that occurs when two or more fundamental frequencies are present in an electronic circuit. Passive components must eliminate or minimize nonlinearities known to generate IM. Two sources which create nonlinearities are contact junctions and ferromagnetic materials. Small separation of contact surfaces can generate microscopic arcing. The use of nickel or steel can also generate IM due to nonlinear voltage to current ratio.



Subminiature, Microminiature



Wireless





Miniature



Standard

	Micro, Subminiature						Miniature		
<b>Series</b>	<b>MMCX</b>	<b>MCX</b>	<b>1.0/2.3</b>	<b>SMB</b>	<b>SMC</b>	<b>SMA</b>	<b>1.6/5.6</b>	<b>BNC</b>	<b>BNC TWIN</b>
	908	919	102	903	903	901	156	31, 456	31
<b>Impedance</b>	50 ohms nominal	50 ohms nominal	50 ohms nominal	50 and 75 ohms nominal	50 ohms nominal	50 ohms nominal	75 ohms nominal	50 and 75 ohms nominal	non-constant
<b>Frequency Range</b>	0-6 GHz	0-6 GHz	Threaded: 0-10 GHz Push-Pull: XX GHz	0-4 GHz	0-10 GHz	S/R: 0-18 GHz High Performance: 0-26.5 GHz	0-1 GHz	0-4 GHz	0-100 MHz
<b>VSWR</b>	1.2 max (straight connectors)	1.3 max (straight connectors)	1.3 max (straight connectors)	1.35 max (straight connectors)	1.3 max	1.25 max 0-18 GHz		1.3 max (straight connectors)	n/a
<b>Voltage Rating</b>	500 volts peak	335 volts peak	350 volts peak	335 volts peak	335 volts peak	500 volts peak	330 volts peak	500 volts peak	100 volts peak
<b>Temperature Range</b>	-40°C to +90°C (Teflon insulators)	-65°C to +165°C (Teflon insulators)	-40°C to +155°C (Teflon insulators)	-65°C to +165°C (Teflon insulators)	-65°C to +165°C (Teflon insulators)	-65°C to +165°C (Teflon insulators)	-40°C to +165°C (Teflon insulators)	-65°C to +165°C (Teflon insulators)	-65°C to +165°C (Teflon insulators)
<b>Cable Termination</b>	Crimp solder	Crimp solder	Crimp-solder	Crimp-solder	Crimp-solder	Crimp solder	Crimp-crimp	Crimp, clamp, Suretwist®, solder	Clamp
<b>Coupling Type</b>	Snap-on coupling	Snap-on coupling	Threaded or Push-Pull Snap-on coupling	Snap-on coupling	Threaded	1/4-36 threaded coupling	M9 x 0.5 threaded coupling	Two stud bayonet lock	Two stud bayonet lock
<b>Standards</b>	CECC 22000	CECC 22220	CECC 22230	Mil-C-39012	Mil-C-39012	Mil-C-39012 Mil-A-55339	CECC 22230	Mil-C-39012 Mil-A-55339	Mil-C-3655
<b>Page</b>	1-12	13-16	17-20	21-36		37-66	XXXX	67-96	97-100

Miniature (cont'd)		Standard			Wireless			
								
TNC	REVERSE POLARITY	UHF	MINI-UHF	TWINAX	7/16	TYPE N	TYPE F	TYPE G
31	various	83	81	82	716	82, S, A	531	531
50 ohms nominal	50 ohms nominal	non-constant	50 ohms nominal	non-constant	50 ohms nominal	50 ohms nominal	75 ohms nominal	75 ohms nominal
0-11 GHz	SMA 0-18 GHz TNC 0-11 GHz BNC 0-4 GHz	0-300 MHz	0-2.5 GHz	0-200 GHz	Coax and S/R: 0-7 GHz Corrugated: 0 - 5.2 GHz	0-11 GHz	0-3 GHz	0-3 GHz
1.3 max (straight connectors)	SMA 1.25 max TNC, BNC 1.30 max	non-constant	1.25 max	n/a	1.3 max (straight connectors)	1.3 max (straight connectors)	30 dB Return Loss @ 1 GHz	30 dB Return Loss @ 1 GHz
500 volts peak	500 volts peak	500 volts peak	335 volts peak	500 volts peak	2700 volts peak	1500 volts peak	15 watts continuous	
-65°C to +165°C (Teflon insulators)	-65°C to +165°C (Teflon insulators)	-55°C to +149°C (Phenolic insulators)	-55°C to +85°C (Polypropylene insulators)	-55°C to +85°C (Styrene insulators)	-40°C to +150°C (Teflon insulators)	-65°C to +165°C (Teflon insulators)	-40°C to +60°C	-40°C to +60°C
Clamp, crimp, solder	Crimp	Solder, crimp	Crimp	Clamp	Crimp, solder, clamp	Clamp, crimp-solder	Solder	Solder
7/16-28 threaded coupling	SMA 1/4-36 threaded TNC 7/16-28 threaded BNC bayonet	5/8-24 threaded coupling	3/8-24 threaded coupling	3/4-20 threaded coupling	M29-1.56 g threaded coupling	5/8-24 threaded coupling	Push-on	Push-on
Mil-C-39012 Mil-A-55339	Mil Std 348 interface	IEC Publication 169-12	IEC Publication 169-12	Mil-C-3655	IEC 169-4 DIN 47223	Mil-C-39012 Mil-A-55339	—	—
XXX	XXX	XXX	XXX	XXX	XXX	XX	XXX	XXX

# RF Connectors Cable Selection Chart

Series	908	919	102	903	901	156	31, 456	31	
	MMCX	MCX	1.0/2.3	SMB	SMC	SMA	1.6/5.6	BNC	BNC TWIN
6,6 Type, Belden 9248								108-109,125	
8, 9, 11, 213, 214								109,126	
22									
55, 142, 223, 400, TWB 1042, 4001			27,29			59-63,77-78		108-113	
58, 141, TWB 5800			27-29			59-61,77-78		108-113	
Plenum 58, 82907, 88240, 89907								108-109	
20AWG 59, Plenum 59, 59, 62								108-113,125-127	
CATV 59, 6, 7									
Double Braid 59									
Quadshield 59									
108A									
122								109	
140, 210, 302								108,111-113,126	
141B			28			41,42			
144, 165									
174, 188, 316	12-14	19,23	27-29	37-38,45	53	59-63,77-78		108,111-113	
RD188, RD316 (2 braids)	12-14	19		37-38	53	60,77		108,113	
178, 196	12-13	19		37		42		109,113	
179, 187		23	27,29	37-38,45,48	53	59-63		108,111-113,125,127	
RD179 (double braid)								125-126	
180, 195			29	45				109	
196				37					
214, 216, 225, 393									
.047S/R	13-14								
.085 S/R, .086 S/R	12,14	20	27-28			58,60-63,77			
.141 S/R			20	27		58,60-63,77			
.250 S/R									
734A								125-126	
735A TYPE				45,48				125-126	
Helical 1/4, 3/8, 1/2, 7/8, 1 1/4, 1 5/8									
TWB 6001									
.064/.285/1/.405; Belden 8213								108	
.017/.100/1/.150; Belden 8218								108,125	
Belden 8227, 9207, IBM 7362211									
Belden 8281, 88281								108,125	
.031/.198/2/.305 Belden 9231								125	
Belden 9259, 9907, 89907								108,125	
.025/.146/1/.260 Belden 9268								110	
.108/.146/1/.405 Belden 9913									
.103/.286/1/.405 Belden 9914									
Belden 9880, 89880									



# RF Connectors Cable Selection Chart

31	various	82, 5, A	83	81	82	716	531	531
TNC	REVERSE POLARITY	TYPE N	UHF	MINI-UHF	TWINAX	7/16	TYPE F	TYPE G
		227-230,232	187-188					
141,143	151	227-231	188					
141,143-144	157	227-232	187-188	195				
141-144		227,229	187,188	195				
	172							
144			187					
		227,229-230						
141,144	151-152,157	227,231-232						
	152							
141								
		227-230				266-267		
		227,230,232						
	151-152	227,230,232				266,268		
		227,230,232				266,268		
		228,241-243				264		
		227-229						
		227						
		227						

## MMCX



Amphenol's MicroMate™ MMCX connector line is a family of products designed as the next generation 50 ohm microminiature surface mount coaxial interconnection system. Providing a more robust interface for greater durability, this series is ideal for high volume wireless SMT or PCMCIA applications in cellular base stations, cellular phones and personal communicators, global positioning systems (GPS) and wireless LAN (WLAN) applications.

## MCX



To address the rapid implementation of the U.S. digital cellular PCN infrastructure, Global Positioning Systems (GPS) and Instrumentation and Wireless LAN Systems, Amphenol has optimized its MCX product offering to target these high growth market applications.

The growth rate of these emerging markets has fueled an increasing demand for subminiature coaxial connectors with very good electrical performance to 6 GHz.

## 1.0/2.3



The 1.0/2.3 series of coaxial connectors are designed for telecommunication systems requiring a subminiature 50 ohm slide on / screw on connector. These connectors comply with the requirements of DIN41626, DIN 47297 INFC 93569 INFC 93571 and CECC22230. The connectors perform DC through 10 GHz, and feature crimp cable termination for low installation cost.

## SMB



SMB connectors feature quick connect/disconnect snap-on mating and are available in both 50 and 75 ohm impedance structures. For maximum space utilization, Amphenol also offers a high density 75 ohm version. This series of connectors conform to the requirements of MIL-C-39012 and the interface is in compliance with MIL-STD-348. Using highly efficient die cast molds and high speed fully-automated assembly equipment. Amphenol's SMB connector line offers a cost effective solution for digital cellular PCN, Global Positioning Systems (GPS) and wireless LAN systems needs.

## SMA



Amphenol's 50 ohm SMA connectors are semi-precision subminiature connectors performing DC through 18 GHz. SMA connectors are primarily used where trends toward higher frequencies, miniaturization, and SMA connectors are built in accordance with MIL-C-39012 and CECC 22110/111, and are available for a variety of flexible and semi-rigid cables. Amphenol's line of brass SMA connectors provide a cost effective solution for applications where stainless steel construction is not required.

## SMC



SMC connectors feature 10-32 threaded coupling with broadband performance with low reflection from DC-10 GHz. This series of connectors conforms to the requirements of MIL-C-39012 and the interface is in compliance with MIL-STD-348. These connectors are particularly suitable for use in high vibration environments.

## BNC Twin



Amphenol's twin contact connectors are used in balanced line, high sensitivity circuits. These applications typically center on computer networks and equipment and process control devices. The BNC-twin connectors feature the same two-stud bayonet locking mechanism as standard coaxial BNC connectors where quick connect/disconnect is an advantage.

## 7/16



Amphenol's 7/16 connectors are designed for use in medium to high power communication systems. These connectors perform exceptionally well in multichannel cellular systems where power levels approximate 100 watts per channel. Designed for both flexible as well as corrugated cables, these connectors are used in a variety of cellular base station and broadcast communication applications. Amphenol's designs offer superior IMD characteristics and assembly onto corrugated cable has been greatly simplified.

## Type N



Type N connectors are medium size threaded connectors for use DC through 11 GHz and feature a characteristic 50 ohm impedance structure. Applications for N connectors include base station equipment, broadcast and satellite communication systems as well as test and instrumentation equipment. Connector performance is per MIL-C-39012, with commercial grade versions available for the most popular configurations. Cable termination includes clamp styles and crimp styles, and connectors are available for the most widely used coaxial cables.

## Twinax



Amphenol twin contact connectors are used in balance line, high sensitivity circuits. The keyed twinax style of connectors feature keyway polarization to insure system integrity and prevent signals from being mixed. These connectors have been primarily used on computer mainframe and peripherals and related network applications and are designed to terminate large size twinaxial cables.

## TNC



Amphenol TNC connectors were originally developed for aircraft and missile application where extreme vibration is a factor. TNC connectors are of miniature size like the BNC connector but feature a threaded coupling nut for application requiring performance through 11 GHz. Chosen for their durability and reliability, TNC connectors are widely used in the cellular/mobile communication industry for equipment cabling and antenna interfaces.

## 1.6/5.6



The 1.6/5.6 is a miniature 75 ohm connector primarily designed for use in the telecommunication industry. The snap-on mating face allows for quick mating for test purposes, and it is also threaded to provide a durable condition when mated. Crimp/crimp cable terminations provide ease of assembly and low installation costs, and the small size allows for dense packing on equipment.

## UHF



Amphenol UHF connectors are the original radio frequency connector interface. They are general purpose units which operate satisfactorily DC to 300 MHz. Applications include citizens band radio receivers, public address systems, and a variety of other low frequency system applications where cost is a prime consideration.

## Mini-UHF



Mini-UHF connectors are a miniature version of the original UHF connector and feature a threaded coupling mechanism for reliable mating. The mini-UHF connector is designed for use in cellular mobile telephone systems where size, weight, and cost are critical. Featuring crimp cable termination for low installation costs, these connectors provide excellent RF performance in applications through 2.5 GHz.

## Type F



Amphenol has developed a variety of board level F receptacles for use on high speed modems and CIU's. These connectors utilize Amphenol's unique female contact design featuring a true cylindrical coaxial contact. As a result, superior RF performance and excellent insertion / withdrawal characteristics are achieved. We also offer designs capable of handling up to 15 amps for future set-top box applications. F receptacles are available in multiple styles including SMD versions complimenting Amphenol's line of drop F connectors and adapters.

## Type G



Amphenol has developed a range of high performance G receptacles for use in today's 1 GHz amplifier and fiber optic node equipment designs. Amphenol has also developed a series of 15 amp G receptacles for HFC networks. These connectors are designed to meet the 15 amp current capability required to power loop electronics in support of enhanced telephony services being implemented by CATV MSO's and telco's.

## Reverse Polarity



Amphenol's reverse polarity connectors have been developed to meet the requirements of the FCC part 15.203 dictating the need for a non-standard interface to be used on connectors designed for spread spectrum wireless devices. Amphenol offers reverse polarity interfaces in the SMA, TNC and BNC connector line, allowing the user the greatest flexibility for cable and size constraints. Featuring all crimp terminations, these connectors feature performance consistent with the corresponding non-polarized product family.

## RF MANUFACTURING LOCATIONS

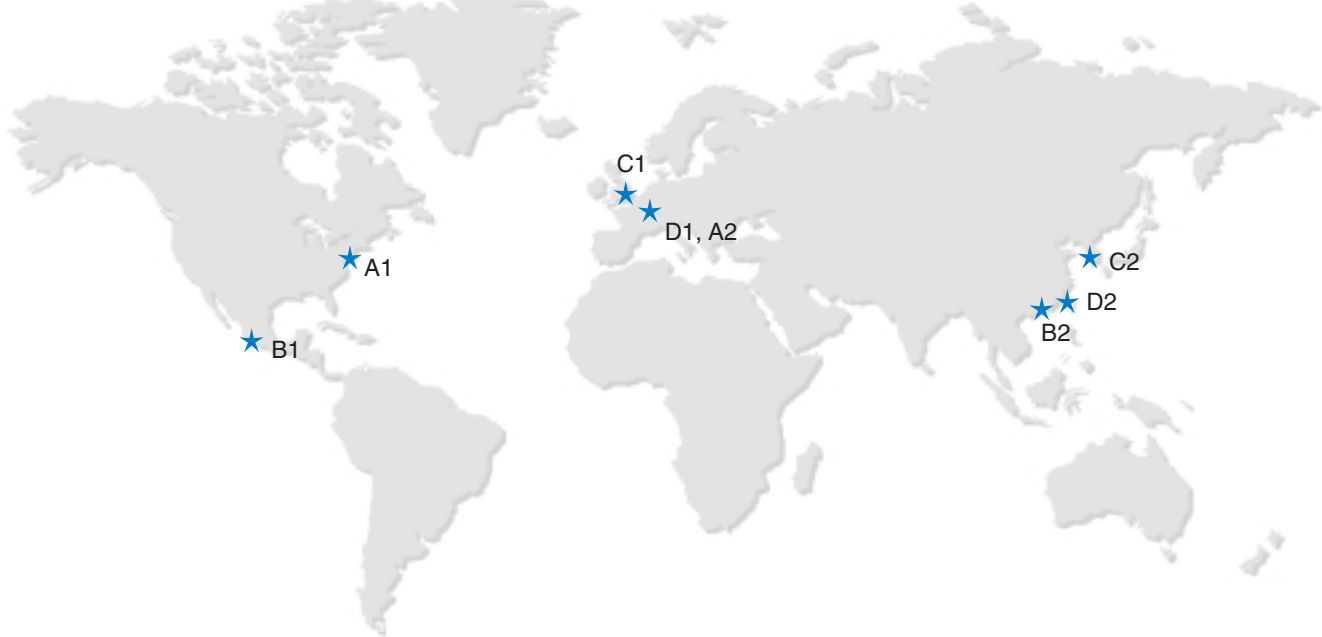

### **United States (A1)**

Danbury, CT

**Date Founded:** 1932

**Products Manufactured:** MMCX, MCX, 1.0/2.3, SMB, SMA, 1.6/5.6, BNC, TNC, Reverse Polarity, Type N, Twinaxial, UHF, Mini-UHF, 7/16, Quarter Wave Stubs, Type F, Type G, C, SC, HN, TXL and TWB cables, and Cable Assemblies

**Plant Size:** 177,000 Square Feet

**ISO 9001**



### **Mexico (B1)**

Nogales, Sonora

**Date Founded:** 1985

**Products Manufactured:** BNC, TNC, UHF, Type C, SMA, SMC, Type F, TXL, and Cable Assemblies

**Plant Size:** 27,558 Square Feet

**ISO 9002**



### **Taiwan (B2)**

Ren-Der Shiang, Tainan Hsien

**Date Founded:** 1982

**Product Manufactured:** MCX, SMA, SMB, BNC, TNC, N, UHF, Twinaxial, FME and Cable Assemblies

**Plant Size:** 64,600 Square Feet

**ISO 9001**





## France (D1)

Dole, Cadex, France

**Date Founded:** 1928

**Product Manufactured:** 1.0/2.3 DIN, 0.8/2.7 DIN, 1.6/5.6 DIN, MCX, SMA, SMB, SMC, TNC, N, 3.5/12 (CATV), RF Switches, Cable Assemblies and Antennas

**Plant Size:** 121,000 Square Feet

**ISO 9001**



## France (A2)

Thyez, France

**Date Founded:** 1986

**Product Manufactured:** RF Subcomponents

**Plant Size:** 125,000 Square Feet

**ISO 9001**



## England (C1)

Kent, Great Britain

**Date Founded:** 1957

**Product Manufactured:** Custom RF Connectors, Lightning Protection, and Cable Harnesses

**Plant Size:** 135,000 Square Feet

**ISO 9001, BS9000/CECC Manufacturing & Testing House, CAA, DESC**



## China (C2)

Schenzehn, China

**Date Founded:** 2000

**Product Manufactured:** MCX, SMA, SMB, BNC, TNC, N, UHF, Twinaxial, FME and Cable Assemblies

**Plant Size:** 110,000 Square Feet



## Korea (D2)

Bucheon-City, Kyunggi-Do, Korea

**Date Founded:** 1988

**Product Manufactured:** Quarter Wave Stub, Type N, 7/16, and Cable Assemblies

**Plant Size:** 400 Square Meters

**ISO 9001**



## Defining an RF Connector

Radio frequency (coaxial) connectors are specialized devices used to terminate and interconnect coaxial cables which carry high frequency signals.

### Two Minute RF Connector Course

#### Terminology

##### RG-/U:

“Radio Guide/Universal”. Previously a government listing for coaxial cable, replaced by MIL, C-17. RG-/U remains the most common nomenclature for cables used in commercial applications.

##### UG-/U:

“Union Guide/Universal”. Previously a government listing RF connectors, replaced by M39012. UG numbers have become commercialized in the sense that the configurations they denote are manufactured widely, but generally they are no longer made to the original UG specifications. Amphenol has available both the original UGs and the new, commercial RFX parts.

##### M39012:

The principal military spec for RF connectors, it calls out electrical and other parameters that must be met. RFX™ connectors are not intended for use in M39012 applications.

#### Types and Styles:

Cable PLUGS have coupling rings and normally have a male pin center contact. They mate to jacks and receptacles.

Cable JACKS mate to plugs and normally have socket center contacts.

RECEPTACLES normally mate to plugs and are mounted on a panel or equipment chassis. Receptacles usually have socket contacts and normally are open wired (they don't terminate cable).

ADAPTERS are used to join two or more incompatible units, such as a plug to a plug, either in the same series or between series.

# Contents

Overview .....	2-4
MMCX (Micromate™) .....	5-16
MCX .....	17-24
1.0 / 2.3 .....	25-34
SMB .....	35-50
SMC .....	51-54
SMA .....	55-84
Precision .....	85-98

# Subminiature



Amphenol's Microminiature family of connectors includes Micromate™ (**MMCX**) and **MCX**. The connectors were developed to satisfy the need for high density, light weight coaxial interconnects. Each series of connectors features individual characteristics that allow the design engineer flexibility in completion of a project.

with performance through 6 GHz, featuring a quick-connect/disconnect snap-on mating style. The product series includes: straight plugs for flexible cables, right angle plugs for flexible and semi-rigid cables and straight jacks for both flexible and semi-rigid cables as well as printed circuit board receptacles.

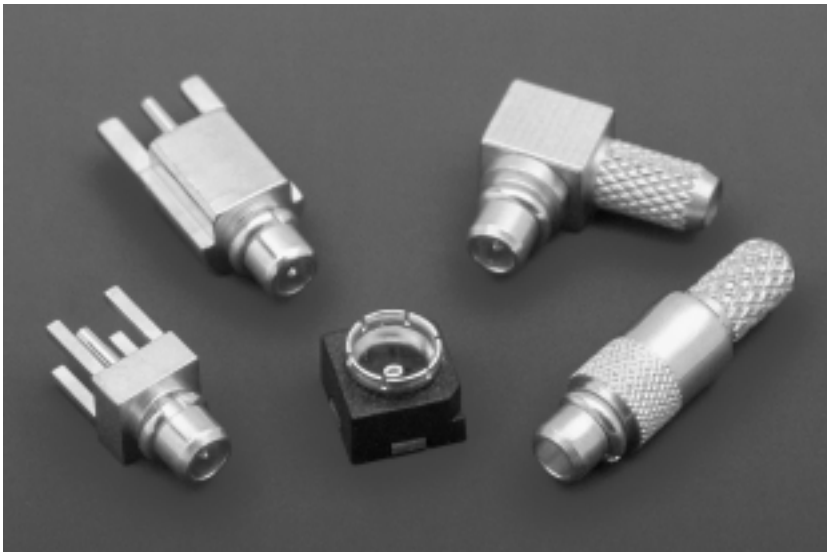

The Micromate™ (**MMCX**) family of products is a 50 ohm coaxial interconnect system with performance to 6 GHz. These connectors are designed for use in wireless data and telecommunications as well as instrumentation. The product series includes: surface mount jack, edge launch jack and plug, right angle and straight cable plugs, and inter-series cable assemblies. Currently, intermateability does not exist between suppliers of microminiature connectors, forcing OEMs into single source position. Amphenol's Micromate™ complies with Europe's specification CECC 22000 compatible with Huber + Suhner.

The **MCX** family of products is also a 50 ohm coaxial interconnect system

Amphenol's Subminiature family of connectors includes **SMA**, **SMB** and **1.0/2.3**. The compact design of these connectors permits dense connector packaging, making these connectors ideally suited to applications where subminiature connector types feature their own mating style and RF performance characteristics, allowing the design engineer wide flexibility of connector choice in the completion of a program.

interconnection requirements and provide good electrical performance from DC to 4 GHz.

Amphenol's **1.0/2.3** connectors are subminiature 50 ohm units available in push/pull types or a threaded coupling mechanism, which provide positive mating and high reliability. The compact design of the 1.0/2.3 permits dense packaging and provides good RF performance from DC to 10 GHz.



Amphenol's family of **SMA** connectors are a 50 ohm semi-precision coaxial interconnect system providing excellent performance from DC to 18 GHz. These high performance connectors are compact in size and feature outstanding mechanical durability and high reliability. Brass SMA connectors are available for commercial applications.

Amphenol's **SMB** connector line is a quick-connect/disconnect snap-on mating system, available in both 50 ohm and 75 ohm impedance. These connectors offer an economic solution to many "limited space"



**Description**

The MMCX series is also called Micromate™. It is Amphenol's smallest RF connector line and was developed in the 1990's.

MMCX is a micro-miniature connector series with a lock-snap mechanism allowing for 360 degrees rotation enabling flexibility in PCB layouts. MMCX connectors conform to the European CECC 22220 Spec.

The micromate family of products is a 6 GHz, 50 Ohm interconnect system. A range of connectors are available including surface mount, edge card, and cable connectors.

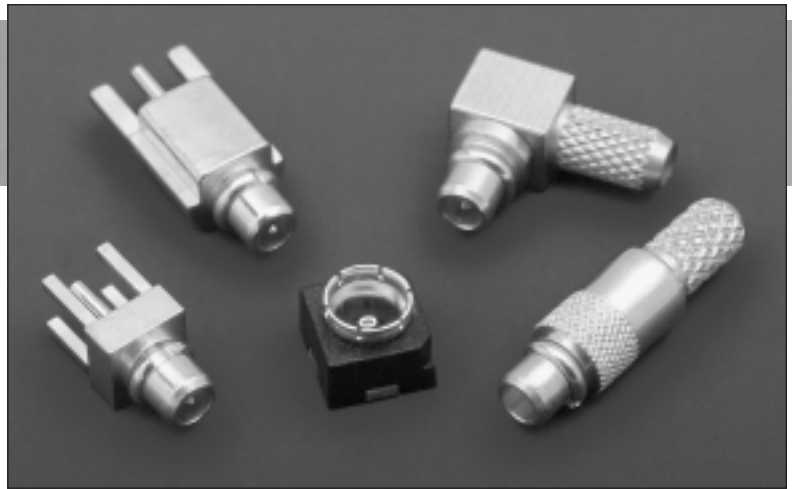

**Features/Benefits**

- Broadband performance with low reflection DC to 6 GHz. Low cost combined with high quality.
- Conforms to European CECC 22000 specifications. Provides customer with second source.
- Quick connect/disconnect snap-on mating reduces installation time.
- Available in many styles: Plugs (Straight and Right Angle) and Printed Circuit Board (Straight and Right Angle). Meets many customer application demands.

**Application**

- Antennas
- Base Stations
- Broadband Communications
- Cable Assemblies
- Components
- GPS
- Instrumentation
- PCMCIA Cards
- Radio Boards
- Satcom
- Telecom

**MMCX**

Specifications	6
Surface Mount	7
Application Notes	8
Edgecard & PCB Mount	9-11
Application Notes	10
Cable Connectors	12-14
Between Series Cable Assemblies	15

## ELECTRICAL

	CECC22000	Test Requirement
Impedance		50 Ohm
Frequency Range		DC thru 6 GHz
VSWR SMT and Edgecard (Mated Pair) DC - 4 GHz 4-6 GHz  Cabled Straight, Semi-Rigid Straight, Flex Right Angle, Semi-Rigid Right Angle, Flex	4.4.1	1.15 Max 1.40 Max  1.15 Max 1.20 Max 1.20 Max 1.25 Max
Dielectric Withstanding Voltage (at Sea Level)	4.4.5	500 V rms, 50 Hz
Working Voltage (at Sea Level)	4.4.4	≤170 V rms, 50 Hz
Insulation Resistance	4.4.4	≥500 MΩ
Contact Resistance Center Conductor Outer Conductor	4.4.2 4.4.3	≤10 mΩ ≤5 mΩ

NOTE: These characteristics are typical and may not apply to all connectors.

## ENVIRONMENTAL

	CECC22000	Test Requirement
Temperature Range		-40°C thru 90°C
Temperature Shock	4.6.7	Mil-STD-202, Method 107
Humidity	4.6.6	Mil-STD-202, Method 103, Condition B
Vibration	4.6.3	3 cycles, 3 opposite directions, 10-150 Hz, 10-60 Hz: 0.75mm/.030 in., 60-150Hz 10G's
Mechanical Shock	4.6.4	Mil-STD-202, Method 213, Condition B

## MECHANICAL

	CECC22000	Test Requirement
Engagement Force	4.5.4	≤3.4 lbs.
Disengagement Force	4.5.4	1.4 lbs. to 3.4 lbs.
Contact Captivation	4.5.2	2.3 lbs.
Durability (Machined)	4.7.1	≥500 cycles

## MATERIAL

Connector Part	Standards	Material	Plating
Leads	QQ-C-530	BeCu	Gold
Contact Socket	QQ-C-530	BeCu	Gold
Outer Conductor	QQ-C-530	BeCu	Gold
Housing (SMT)	—	Liquid Crystal Polymer	—
Insulator	ASTM-D1457	PTFE	—

## JACK

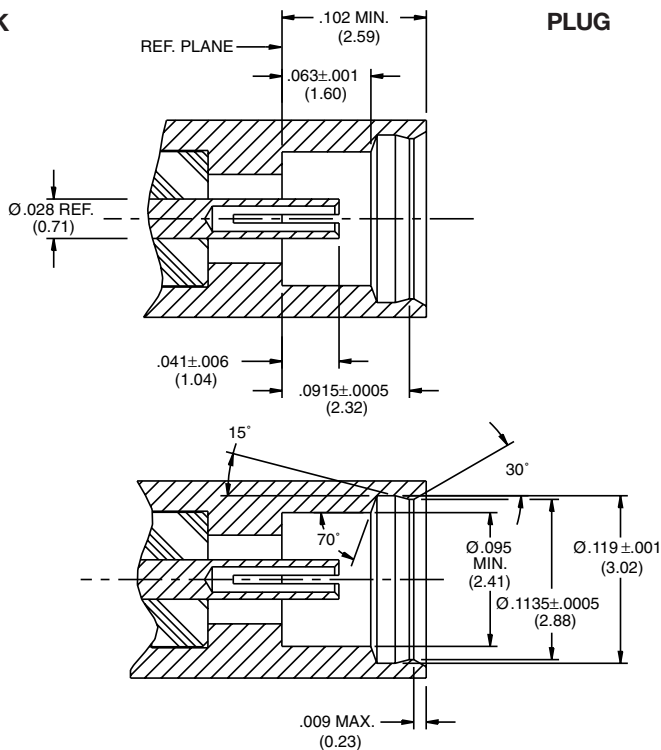

## PLUG

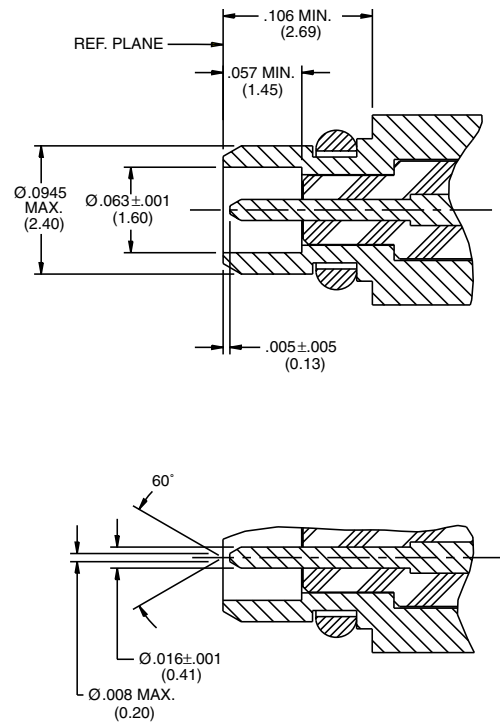



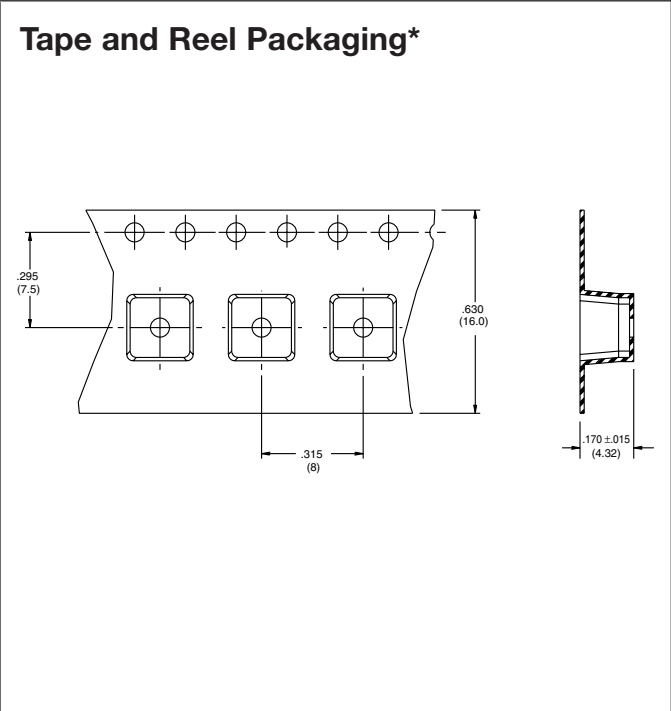
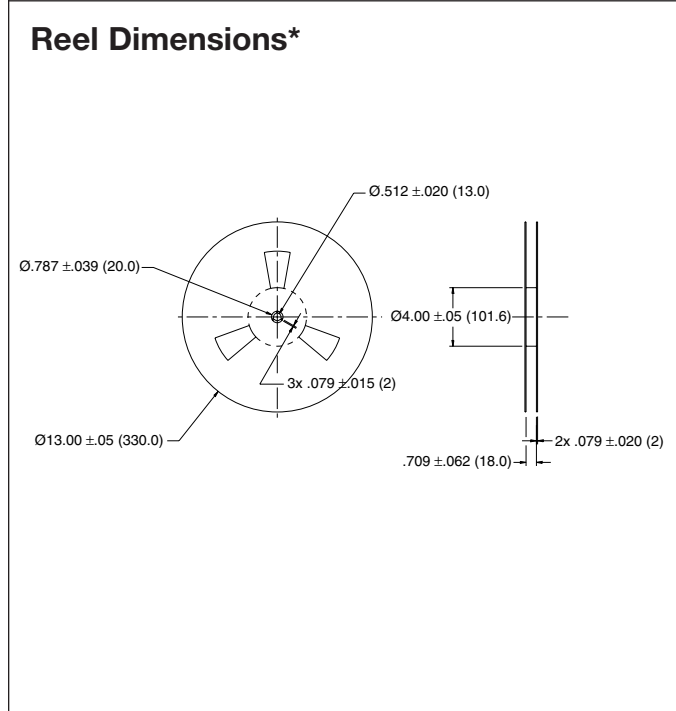
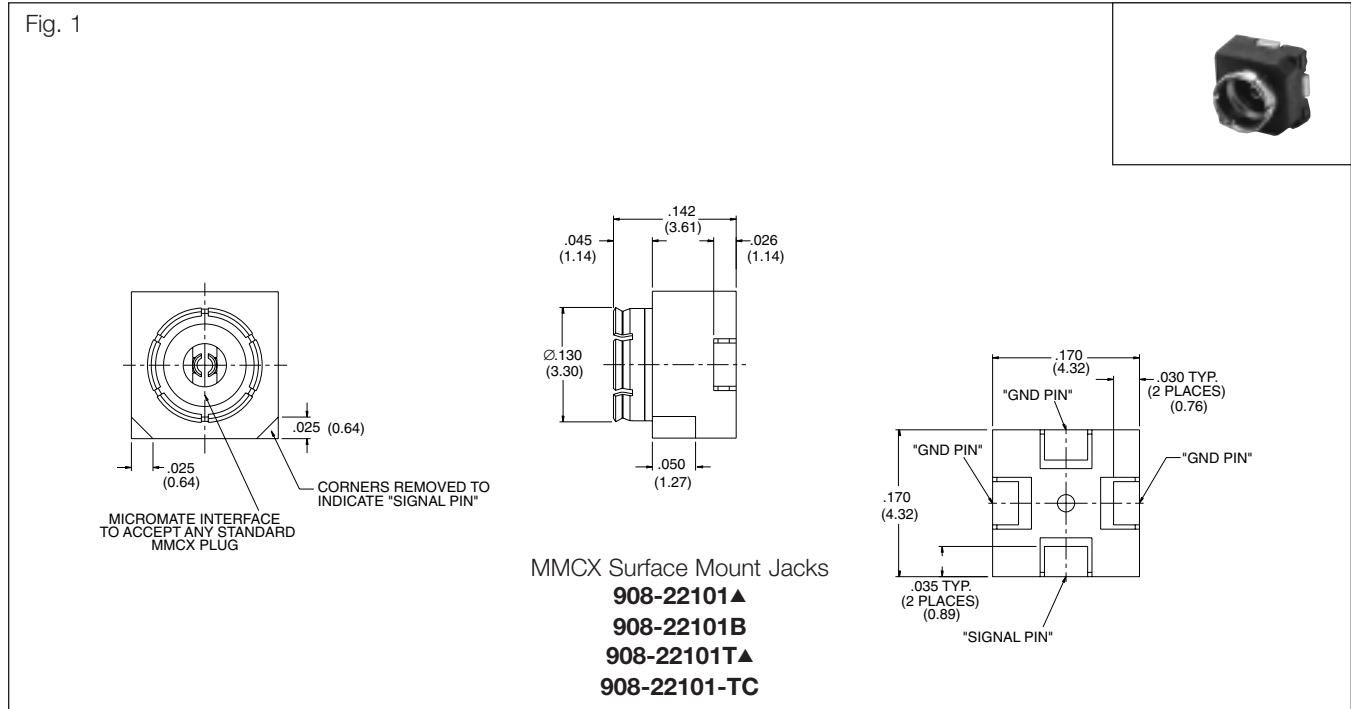

\* Blister tape packaged uniformly for vertical mounting and supplied in accordance with IEC 286-3/EIA 481

## MicroMate™ (MMCX) SURFACE MOUNTS

Description	Plt.	Ins.	Contact & Body	Mtg. Patterns/Page No.	Amphenol Number	Fig.
SMT Jack, Single Packed	P11	L1	Stamped Beryllium Copper	Fig. M3/8 or M4/8	▲ <b>908-22101</b>	1
SMT Jack, Bulk Packed	P11	L1	Stamped Beryllium Copper	Fig. M3/8 or M4/8	<b>908-22101B</b>	1
SMT Jack, Tape & Reel	P11	L1	Stamped Beryllium Copper	Fig. M3/8 or M4/8	▲ <b>908-22101T</b>	1
SMT Jack, Tape & Reel w/cap	P11	L1	Stamped Beryllium Copper	Fig. M3/8 or M4/8	<b>908-22101-TC</b>	1

▲ Distributor Stocked

## Dimensions for Clearance and Mated Height

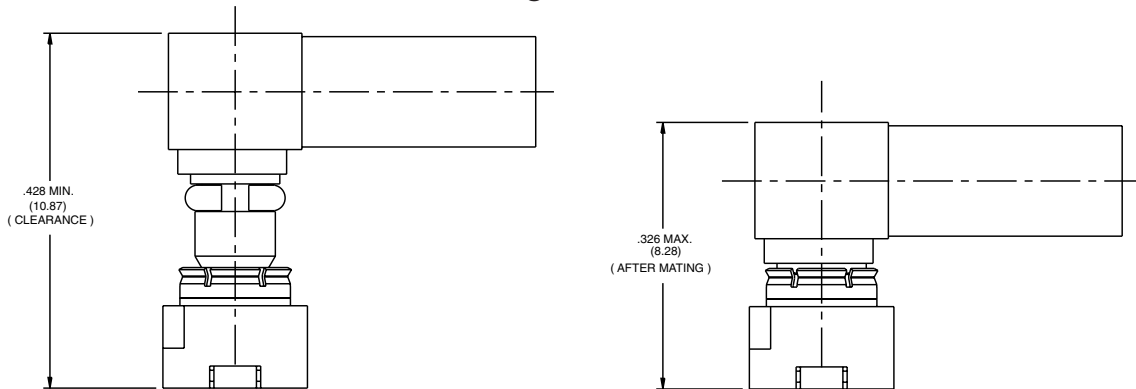

## Pick and Place Automation

- Amphenol Surface Mount connectors can be assembled to printed circuit boards by state of the art pick and place equipment.
  - Connector pick-up by suction tip
  - Optional insertion tip (see illustration)

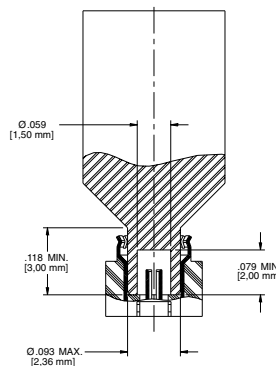

## Application Notes

Amphenol SMT solder joints act as the mechanical bond to the printed circuit board and also functions as the point of electrical contact. With this in mind, the following points should be considered:

- Avoid forces from the cable of the mating connector to the surface mounted connector.
- For connecting and disconnecting of the surface mounted connector only non-axial forces should be applied. Non-compliance may cause excess torque and damage the solder connectors.

## Recommended Mounting Patterns

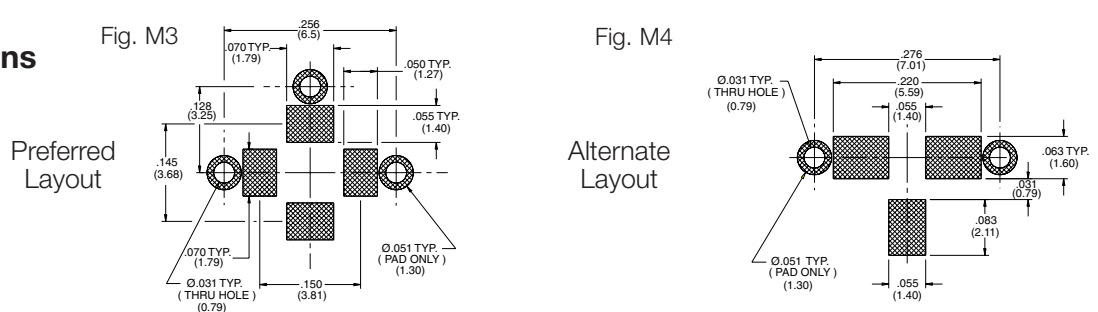

## Soldering

MicroMate (MMCX) product is compatible with the following soldering methods.

- Infrared Soldering (Max 260°C/500°F)
- Vapor Phase Soldering (215°C/419°F)
- Normal Eutectic Solder Paste (63% tin, 37% lead)
- If stenciled or screened in accordance with the mounting patterns above

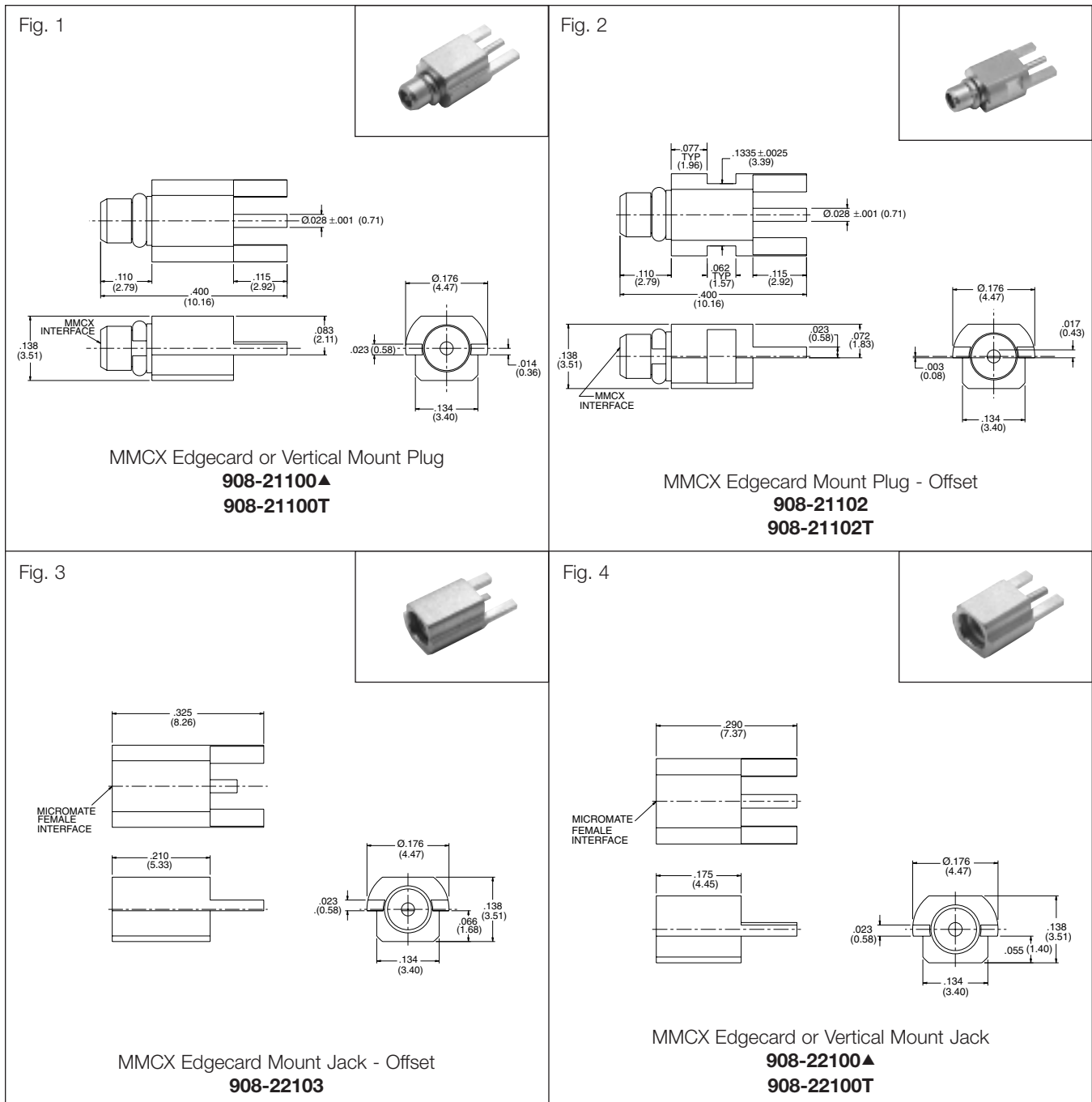

## MicroMate™ (MMCX) EDGECARD AND PCB MOUNTS

Description	Plt.	Ins.	Contact	Mtg. Patterns/Page No.	Construction Notes	Amphenol Number	Fig.
Edgecard Plug	P11	D1	Brass	Fig. M2/10 & M5/10	Machined	▲ <b>908-21100</b>	1
Edgecard Plug, Tape & Reel	P11	D1	Brass	Fig. M2/10 & M5/10	Machined	<b>908-21100T</b>	1
Edgecard Plug, Offset	P11	D1	Brass	Fig. M5/10	Machined	<b>908-21102</b>	2
Edgecard Plug, Offset, Tape & Reel	P11	D1	Brass	Fig. M5/10	Machined	<b>908-21102T</b>	2
Edgecard Jack	P11	D1	BeCu	Fig. M2/10 & M5/10	Machined	▲ <b>908-22100</b>	4
Edgecard Jack, Tape & Reel	P11	D1	BeCu	Fig. M5/10	Machined	<b>908-22100T</b>	4
Edgecard Jack - Offset	P11	D1	BeCu	Fig. M5/10	Machined	<b>908-22103</b>	3

▲ Distributor Stocked

## Dimensions for Clearance and Mated Height

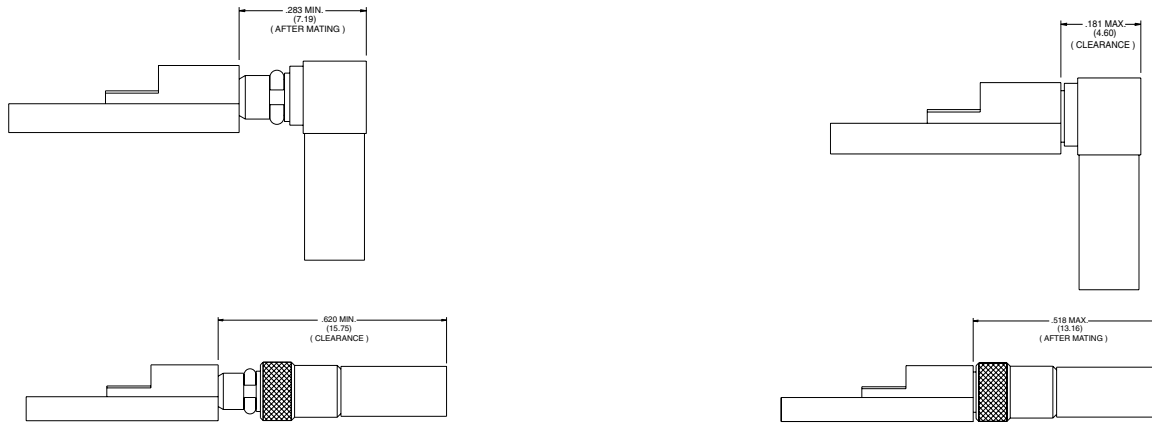

### Pick and Place Automation

- Amphenol Edgecard Mount connectors can be assembled to PC boards with state of the art pick and place equipment.
  - Connector pick-up by suction tip

### Application Notes

- Avoid radial forces from the cable of the mating connector to the surface mount connector
- Secure the cable sufficiently
- Apply only axial forces during mating and de-mating

### Mounting Patterns

Fig. M1

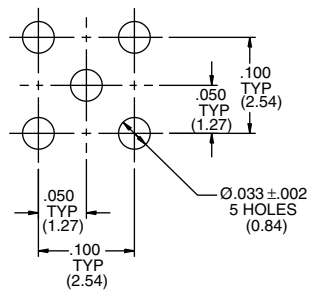
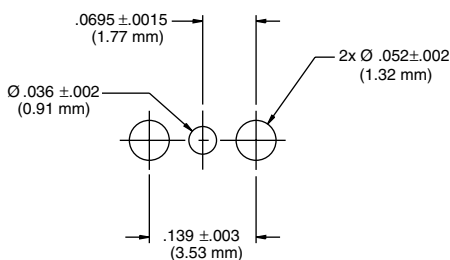
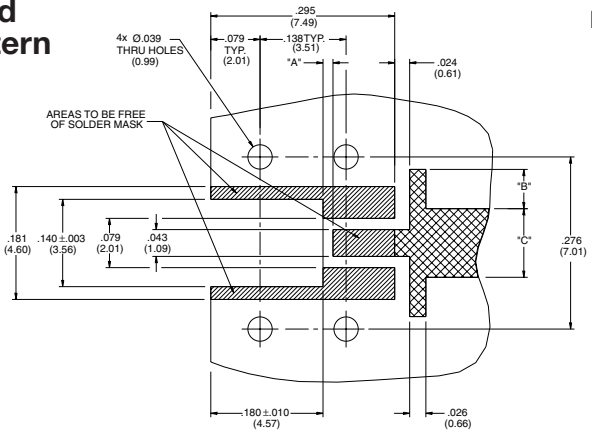

Fig. M2



### Recommended Mounting Pattern

Fig. M5



Thickness (FR 4, Er=4.6)	"A"	"B"	"C"
.031 (0.79)	.039 (0.99)	-	.055 (1.40)
.039 (0.99)	.035 (0.89)	.012 (0.30)	.071 (1.80)
.063 (1.60)	.016 (0.41)	.063 (1.60)	.110 (2.79)

MicroMate (MMCX) product is compatible with the following soldering methods.

- Infrared Soldering (Max 260°C/500°F)
- Vapor Phase Soldering (215°C/419°F)
- Normal Eutectic Solder Paste (63% tin, 37% lead)
- If stenciled or screened in accordance with the mounting pattern above

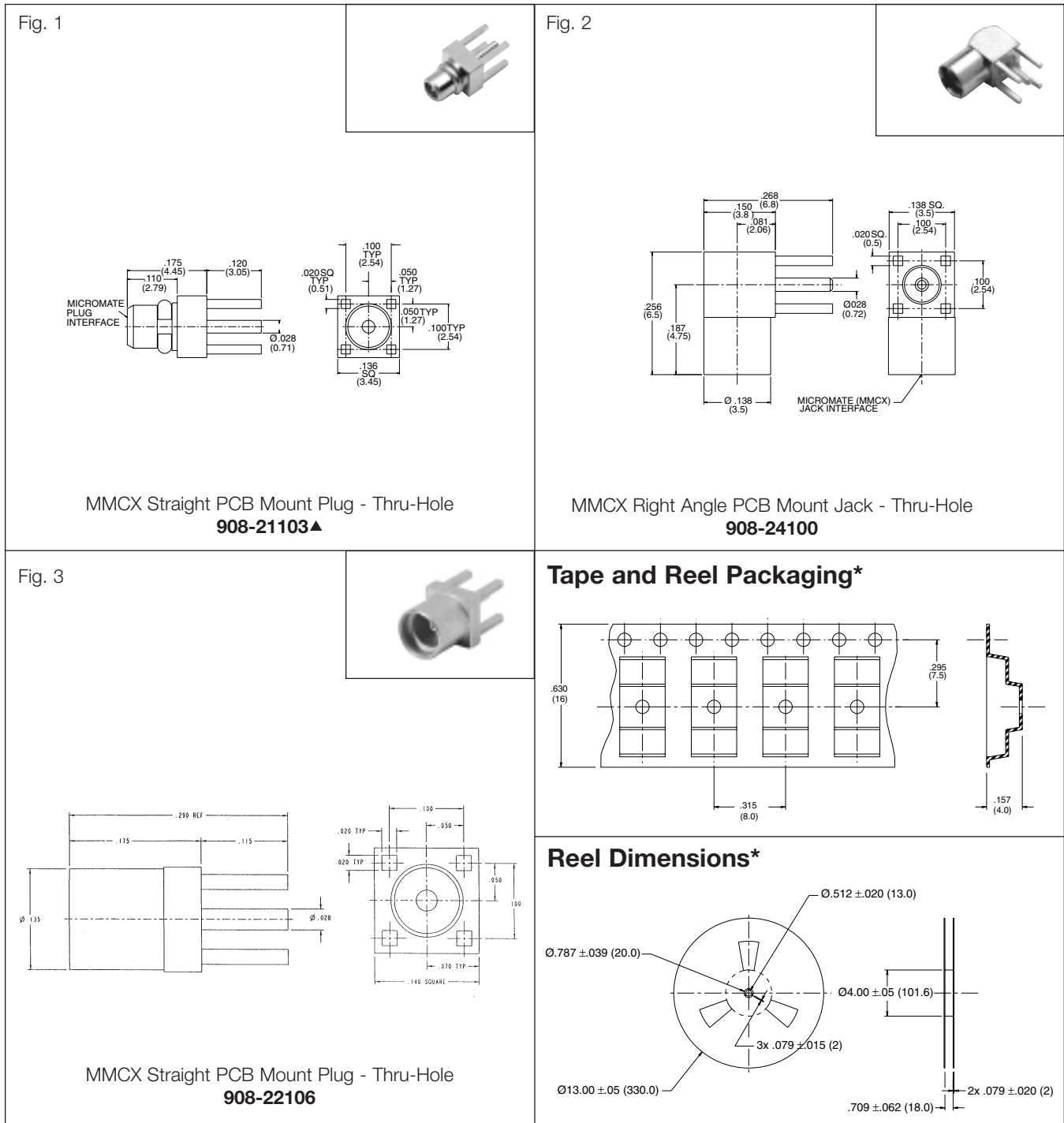

\* Blister tape packaged uniformly for edgcard mounting and supplied in accordance with **IEC 286-3/EIA 481**

## MicroMate™ (MMCX) EDGE CARD AND PCB MOUNTS

Description	Plt.	Ins.	Contact	Mtg. Patterns/Page No.	Construction Notes	Amphenol Number	Fig.
<b>R/A Jack, PCB</b>	P11	D1	BeCu	Fig. M1/6	1 Piece Contact	<b>▲908-24100</b>	2
<b>Straight PCB Plug</b>	P11	D1	Brass	Fig. M1/6	Machined	<b>▲908-21103</b>	1
<b>Straight Jack PCB</b>	P11	D1	BeCu	Fig. M1/6	Machined	<b>▲908-22106</b>	3

▲ Distributor Stocked

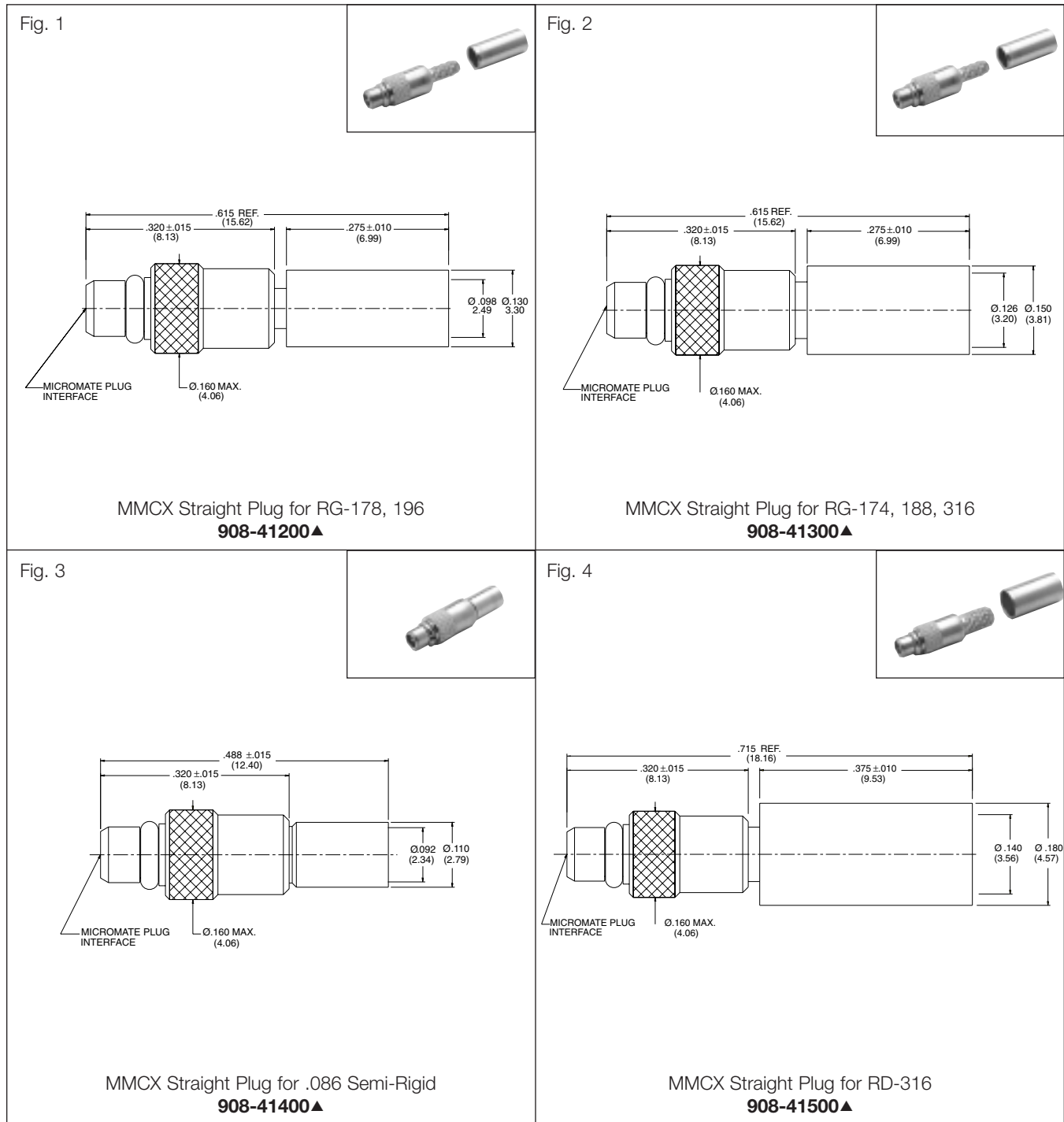

## MicroMate™ (MMCX) CABLE CONNECTORS

Cable RG-/U	Cable Attachment		CAI	Plt.	Ins.	Construction Notes	Amphenol Number	Fig.
	Outer	Inner						
RG-178, 196	Crimp	Solder	C70	P11	D1	Captivated Contact	▲ 908-41200	1
RG-174, 188, 316	Crimp	Solder	C70	P11	D1	Captivated Contact	▲ 908-41300	2
.086 Semi-Rigid	Solder	Solder	C71	P11	D1	Captivated Contact	▲ 908-41400	3
RD-316	Crimp	Solder	C70	P11	D1	Captivated Contact	▲ 908-41500	4

▲ Distributor Stocked

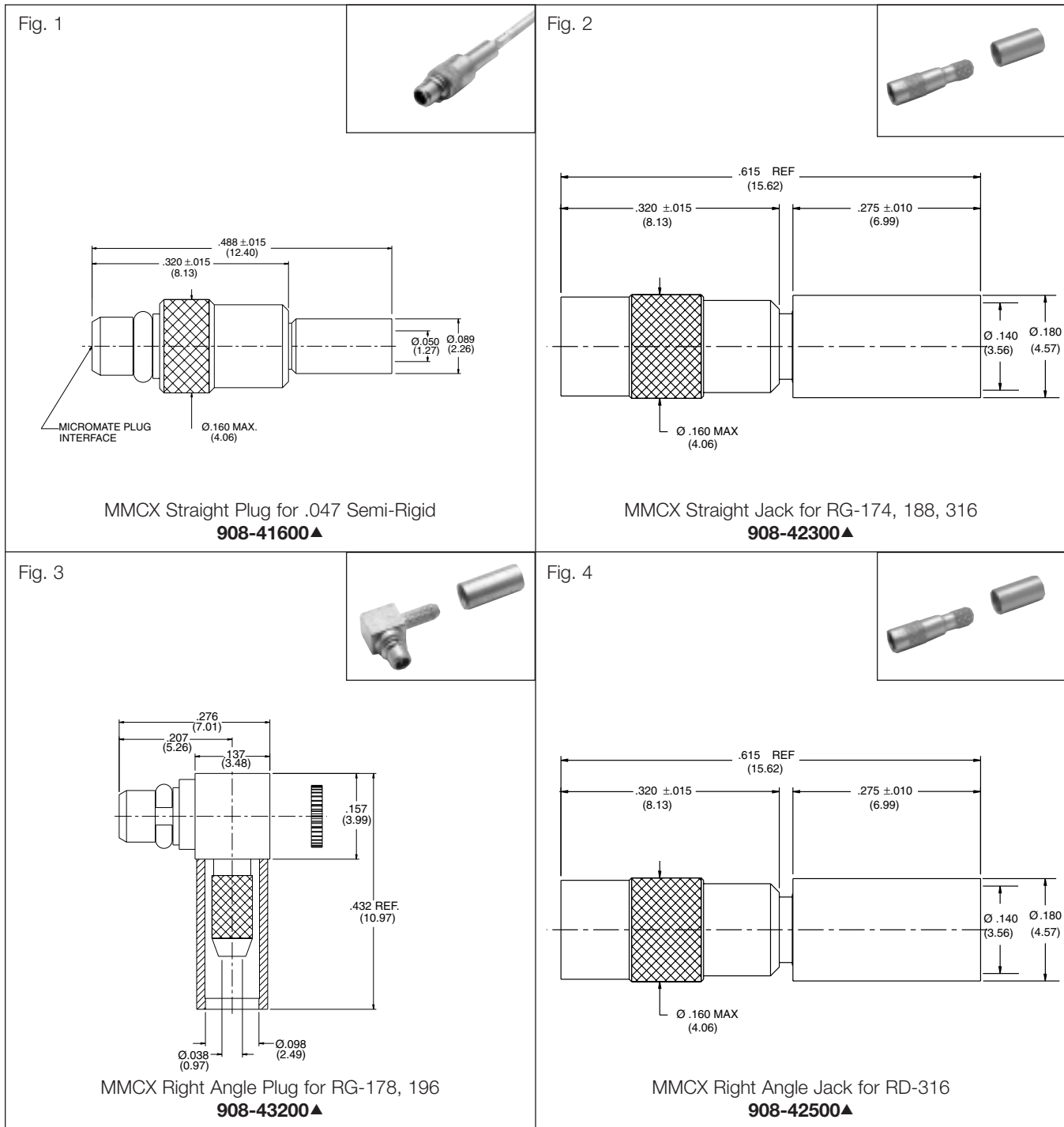

## MicroMate™ (MMCX) CABLE CONNECTORS

Cable RG-/U	Cable Attachment		CAI	Plt.	Ins.	Construction Notes	Amphenol Number	Fig.
	Outer	Inner						
.047 Semi-Rigid	Solder	Solder	C71	P11	D1	Captivated Contact	▲ 908-41600	1
RG-174, 188, 316	Crimp	Solder	C70	P11	D1	Captivated Contact	▲ 908-42300	2
RG-178, 196	Crimp	Solder	C72	P11	D1	Captivated Contact	▲ 908-43200	3
RD-316	Crimp	Solder	C70	P11	D1	Captivated Contact	▲ 908-42500	4

▲ Distributor Stocked

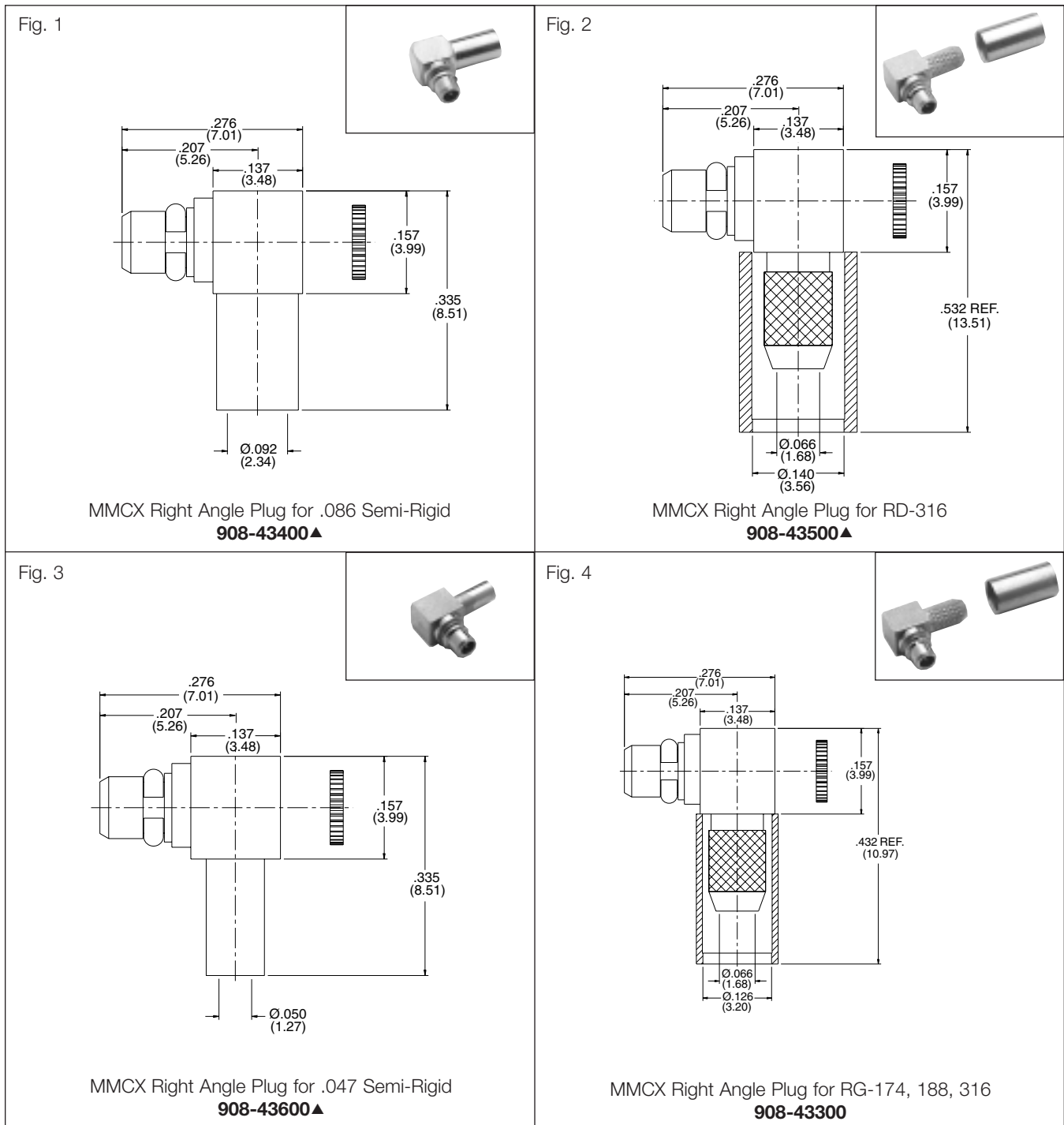

## MicroMate™ (MMCX) CABLE CONNECTORS

Cable RG-/U	Cable Attachment		CAI	Pit.	Ins.	Construction Notes	Amphenol Number	Fig.
	Outer	Inner						
<b>.086 Semi-Rigid</b>	Solder	Solder	C73	P11	D1	Captivated Contact	▲ <b>908-43400</b>	1
<b>RD-316</b>	Crimp	Solder	C72	P11	D1	Captivated Contact	▲ <b>908-43500</b>	2
<b>.047 Semi-Rigid</b>	Solder	Solder	C73	P11	D1	Captivated Contact	▲ <b>908-43600</b>	3
<b>RG-174, 188, 316</b>	Crimp	Solder	C72	P11	D1	Captivated Contact	▲ <b>908-43300</b>	4

▲ Distributor Stocked

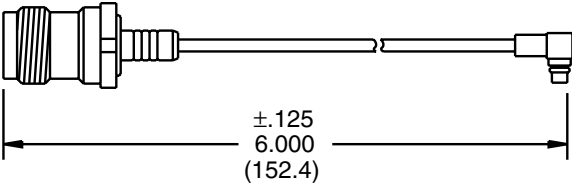
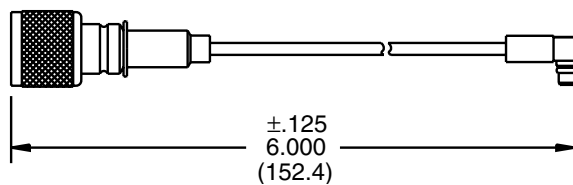
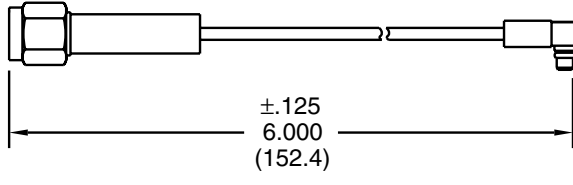
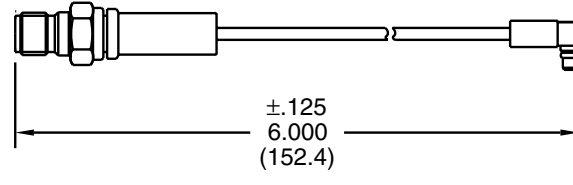
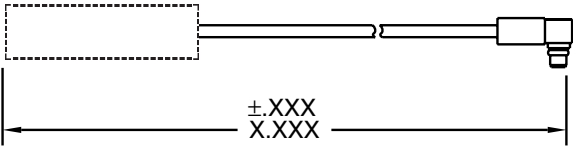

<p>Fig. 1</p>  <p>Right Angle MicroMate Plug to RP-TNC Jack  <b>095-680-58000</b></p>	<p>Fig. 2</p>  <p>Right Angle MicroMate Plug to Straight Mini-UHF Plug  <b>095-680-68000</b></p>
<p>Fig. 3</p>  <p>Right Angle MicroMate Plug to SMA Plug  <b>095-680-98000</b></p>	<p>Fig. 4</p>  <p>Right Angle MicroMate Plug to SMA Jack  <b>095-680-98001</b></p>
<p>Fig. 5</p>  <p>Right Angle MicroMate Plug to          Customer Specified Connector and Cable  <b>095-680-XXXXX</b></p>	



**Description**

MCX connectors conform to the European CECC 22220 Spec and was introduced in the 1980's.

While the MCX uses identical inner contact and insulator dimensions as the SMB, the outer diameter of the plug is .140" which is 30% smaller than the SMB. This series provides designers with options where weight and physical space is limited.

MCX provides broadband capability though 6GHz with a snap-on connector design. A range of connectors are available including PC board and cable connectors.

**Features/Benefits**

- Broadband performance with low reflection DC to 6 GHz. Low cost combined with high quality.
- Quick connect/disconnect snap-on mating reduces installation time.
- Accommodates a wide range of miniature RG flexible coaxial cables including semi-rigid cable provides customer flexibility in their design and manufacturing with a durable connector.

**Application**

- Antenna
- Automotive
- Base Station
- Components
- GPS
- Head End Equipment
- Instrumentation
- PC/LAN
- Radios
- Telecom
- WLAN



**50 Ohm Coaxial Connectors**

Specifications	18
Straight & Right Angle Crimp	19
Straight Solder & PCB	20-21

**75 Ohm Coaxial Connectors**

Specifications	22
Plugs	23
Receptacles PCB	23

### ELECTRICAL

Impedance	50 ohms
Frequency range	0-6 GHz
Voltage rating	335 VRMS
Dielectric withstanding voltage	1000 Volts
VSWR	1.00 @ 2.5GHz (straight) 1.10 @ 2.5GHz (rt. angle)
Contact resistance	Center contact: 5 milliohms; Outer contact: 1.0 milliohms;
Insulation resistance	5000 megohms min.
Insertion loss:	0.10 dB @ 1 GHz

### MECHANICAL

Mating	50 ohm snap-on coupling, per CECC 22220
Engagement forces	engagement 4.5 lbs (20N) max. disengagement 2.3 lbs (10N) min.
Connector affixment to cable	Braid and jacket: hex crimp.
Cable affixment to center contact	Solder
Contact captivation	All types, except as noted
Connector durability	500 mating and unmating cycles min.

### MATERIAL

Body, Metal Parts Finish	Brass per QQB-626 Nickel or Gold
Center contacts gold plated (30 u" gold)	Male: Brass per QQB626 Female: Beryllium copper per QQC 530 heat treated per MIL H 7199
Insulators	PTFE
Gasket	Silicone Rubber
Crimp ferrules	Seamless copper tubing alloy
Finish	Nickel or Gold

### ENVIRONMENTAL

Temperature range	-65°C to + 165°C
Thermal shock	MIL-STD-202 method 107 (test cond. B) except high temperatures @ 200°C
Vibration	MIL-STD-202 method 204, snap-on (test cond. B)
Shock	MIL-STD-202 method 213, snap-on (test cond. B)
Corrosion	MIL-STD-202 method 101 (test cond. B) 5% salt solution.

### PLUG

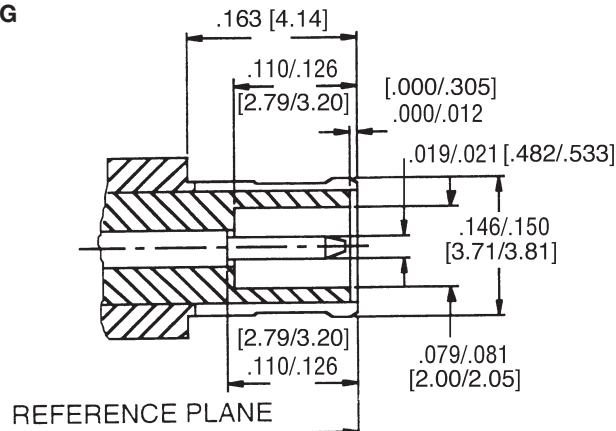



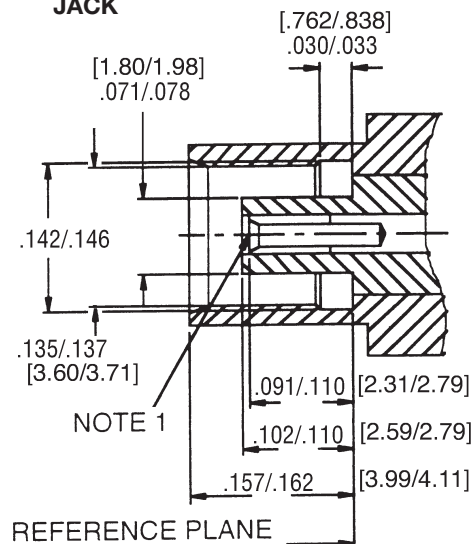

### JACK

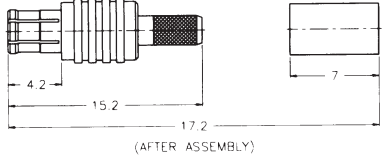

#### NOTE:

1. I.D. to meet VSWR and contact resistance when mated with .48/.53mm diameter pin

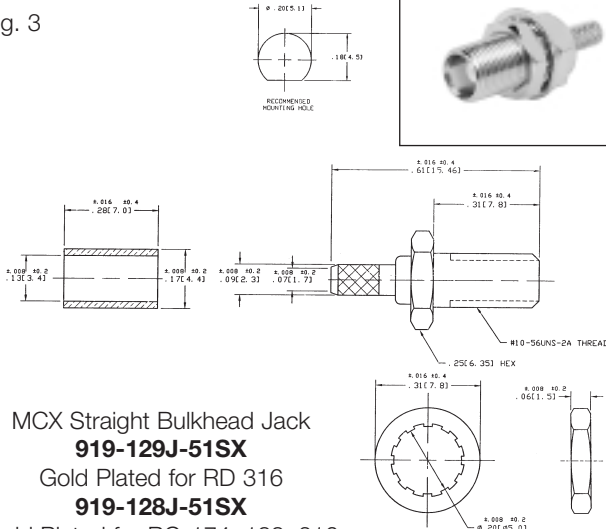
# 50 Ohm Crimp Attachments for Flexible Cable

<p>Fig. 1</p>  <p>MCX Crimp Plug, Crimp  <b>919-101P-51SX</b>          Gold Plated for RG-174, 188, 316  <b>919-101P-51S1X</b>          Nickel Plated for RG-174, 188, 316  <b>919-121P-51SX</b>          Gold Plated for RG-178-196  <b>919-130P-51SX</b>          Gold Plated for RD-316</p>	<p>Fig. 2</p>  <p>MCX Crimp Jack, Crimp  <b>919-107J-51SX</b>          Gold Plated for RG-174, 188, 316  <b>919-107J-51S1X</b>          Nickel Plated for RG-174, 188, 316  <b>919-131J-51SX</b>          Gold Plated for RG-178, 196</p>
<p>Fig. 3</p>  <p>MCX Straight Bulkhead Jack  <b>919-129J-51SX</b>          Gold Plated for RD 316  <b>919-128J-51SX</b>          Gold Plated for RG-174, 188, 316</p>	<p>Fig. 4</p>  <p>MCX Angle Plug, Crimp  <b>919-104P-51AX</b>          Gold Plated for RG-174, 188, 316  <b>919-104P-51A1X</b>          Nickel Plated for RG-174, 188, 316  <b>919-122P-51AX</b>          Nickel Plated for RG-178-196</p>

MCX

## 50 OHM MCX CABLE CONNECTORS

Cable RG-/U	Cable Attachment		CAI	Plt.	Ins.	Construction Notes	Amphenol Number	Fig.
	Outer	Inner						
RG-174, 188, 316	Crimp	Solder	C74	P11	D1	Gold Plated	<a href="#">919-101P-51SX</a>	1
RG-174, 188, 316	Crimp	Solder	C74	P11	D1	Nickel Plated	<a href="#">919-101P-51S1X</a>	1
RG-174, 188, 316	Crimp	Solder	C74	P11	D1	Gold Plated	<a href="#">919-107J-51SX</a>	2
RG-174, 188, 316	Crimp	Solder	C74	P11	D1	Nickel Plated	<a href="#">919-107J-51S1X</a>	2
RD-174, 188, 316	Crimp	Solder	C77	P11	D1	Gold Plated	<a href="#">919-128J-51SX</a>	3
RG-174, 188, 316	Crimp	Solder	C77	P11	D1	Gold Plated	<a href="#">919-104P-51AX</a>	4
RG-174, 188, 316	Crimp	Solder	C77	P11	D1	Nickel Plated	<a href="#">919-104P-51A1X</a>	4
RG-178, 196	Crimp	Solder	C74	P11	D1	Gold Plated	<a href="#">919-121P-51SX</a>	1
RG-178, 196	Crimp	Solder	C74	P11	D1	Gold Plated	<a href="#">919-131J-51SX</a>	2
RG-178, 196	Crimp	Solder	C77	P11	D1	Gold Plated	<a href="#">919-122P-51AX</a>	4
RD-316	Crimp	Solder	C77	P11	D1	Gold Plated	<a href="#">919-129J-51SX</a>	3
RD-316	Crimp	Solder	C74	P11	D1	Gold Plated	<a href="#">919-130P-51SX</a>	1

# 50 Ohm For Semi-Rigid Cable and PCB

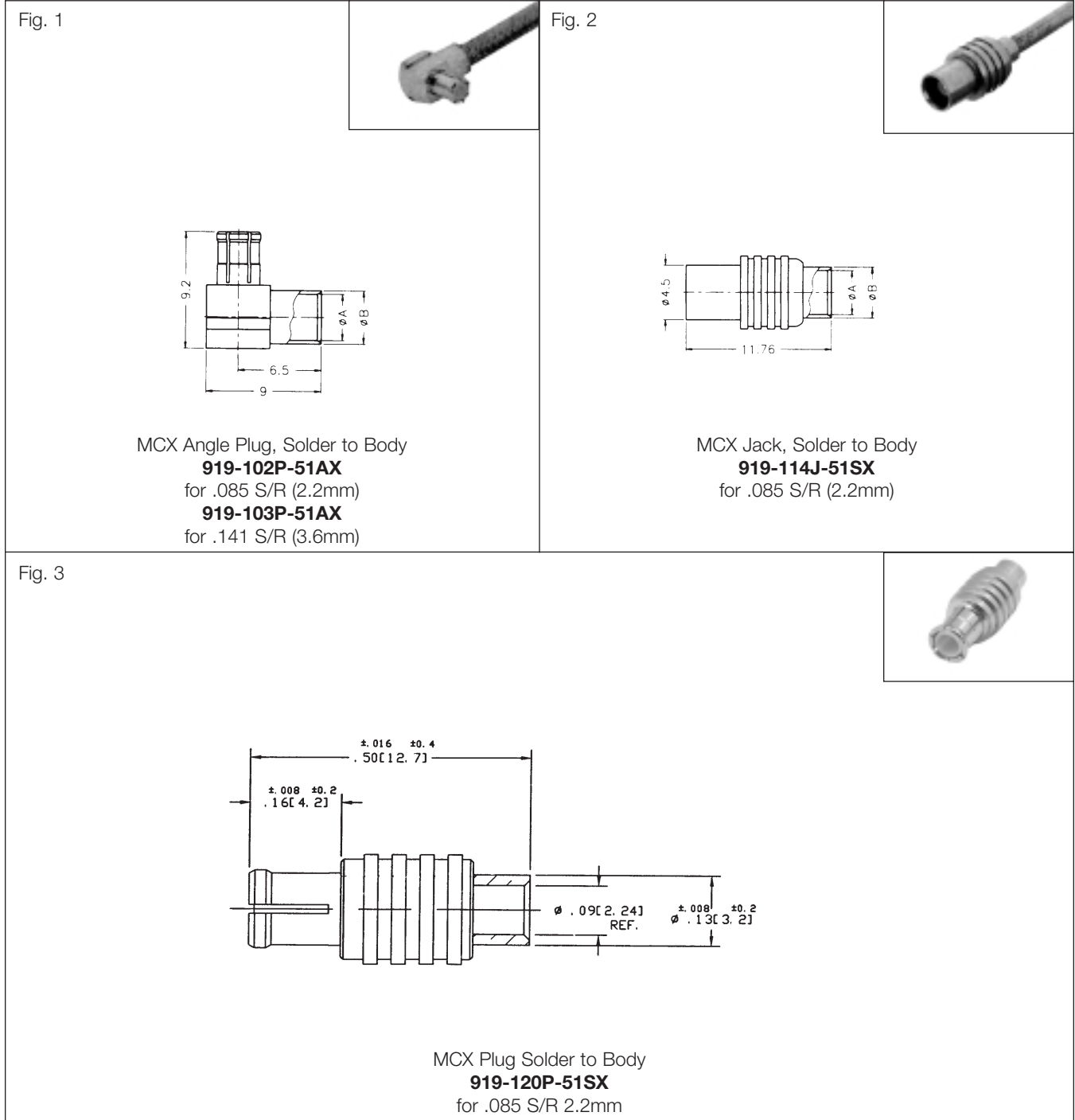

## 50 OHM MCX SEMI-RIGID CABLE CONNECTORS

Cable RG-/U	Cable Attachment		CAI	Plt.	Ins.	Construction Notes	Amphenol Number	Fig.
	Outer	Inner						
.085 Semi-Rigid	Solder	Solder	C76	P11	D1	Gold Plated	<a href="#">919-102P-51AX</a>	1
.085 Semi-Rigid	Solder	Solder	C75	P11	D1	Gold Plated	<a href="#">919-114J-51SX</a>	2
.085 Semi-Rigid	Solder	Solder	C75	P11	D1	Gold Plated	<a href="#">919-120P-51SX</a>	3
.141 Semi-Rigid	Solder	Solder	C76	P11	D1	Gold Plated	<a href="#">919-103P-51AX</a>	1

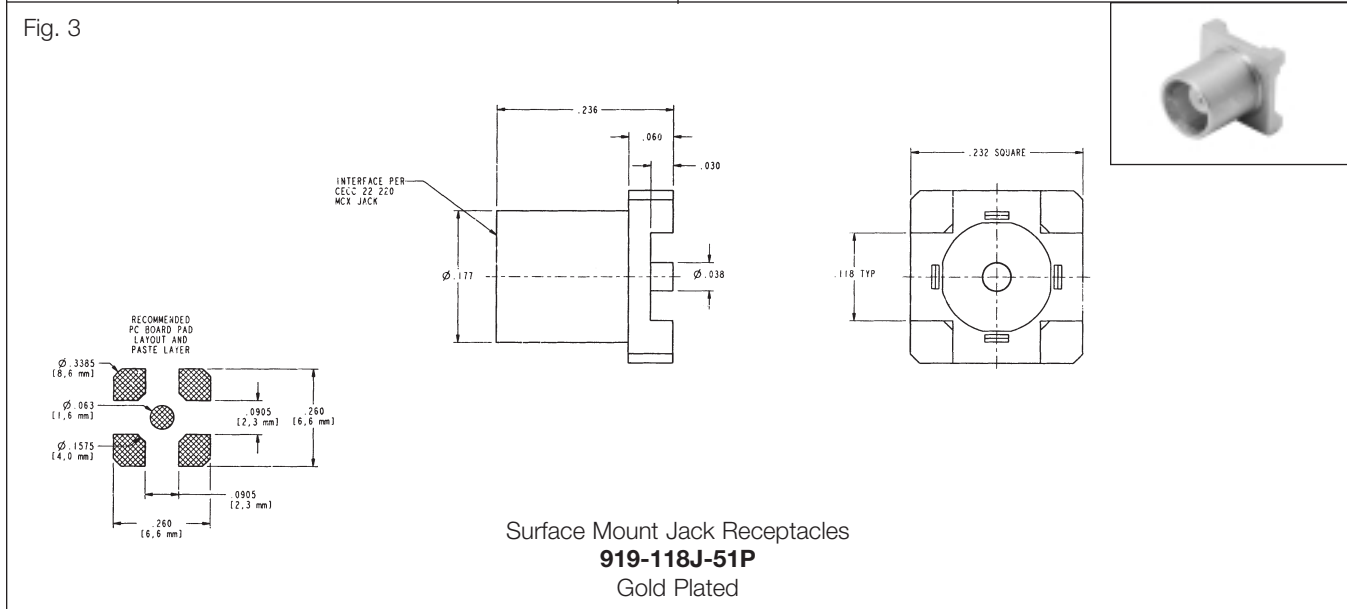
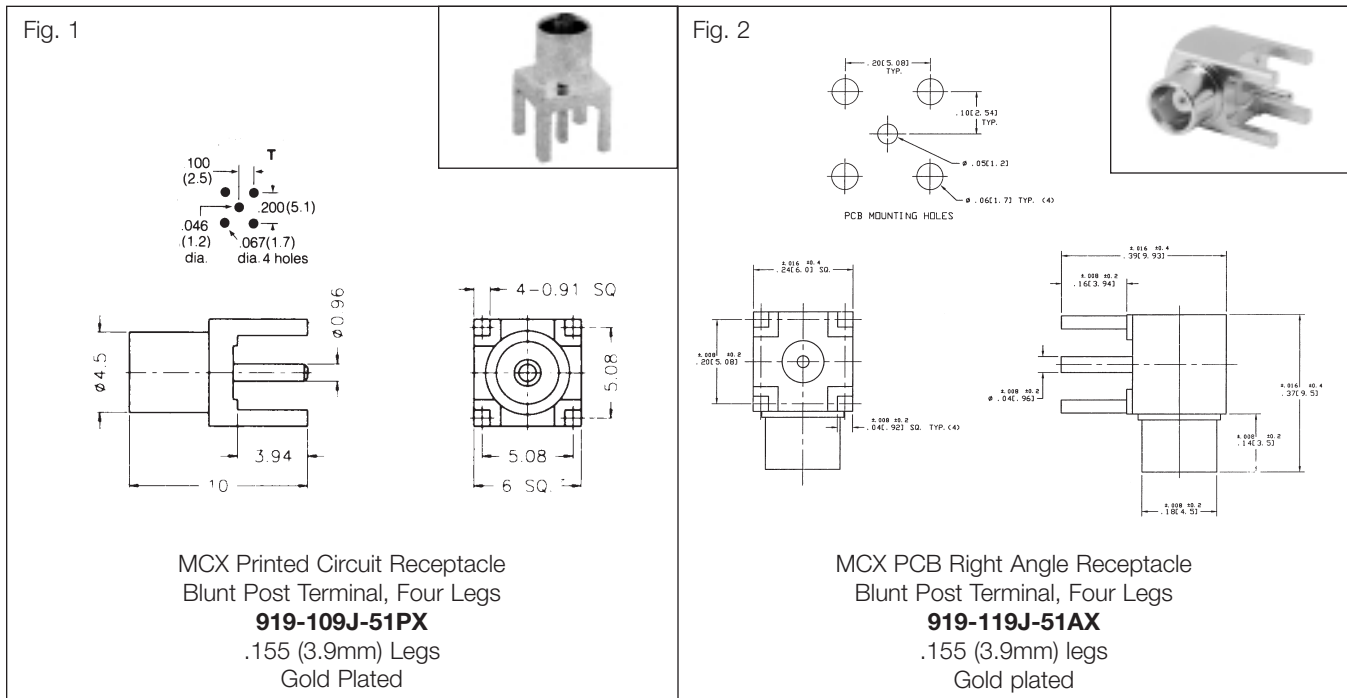

## 50 OHM MCX PCB RECEPTACLES

Description	Terminal Type	Pit.	Ins.	MTG Hole	Construction Notes	Amphenol Numbers	Fig.
PCB Panel Jack Receptacles	Blunt Post	P11	D1	T	Stand Off Pads	<a href="#">919-109J-51PX</a>	1
PCB Panel Jack Receptacles	Blunt Post	P11	D1	T	Stand Off Pads	<a href="#">919-119J-51AX</a>	2

## 50 OHM MCX SURFACE MOUNT

Description	Terminal Type	Pit.	Ins.	MTG Hole	Construction Notes	Amphenol Numbers	Fig.
Surface Mount Jack Receptacles	Blunt Post	P11	D1	—	Surface Mount	<a href="#">919-118J-51P</a>	3



## ELECTRICAL

Impedance	75 ohms
Frequency range	0-6 GHz
Voltage rating	170 Volts
Dielectric withstanding voltage	500 Volts
VSWR	1.06@ 2.5 GHz (straight) 1.08 @ 2.5GHz (rt. angle)
Contact resistance	Center contact: 5 milliohms; Outer contact: 2.5 milliohms;
Insulation resistance	10,000 megohms min.
Insertion loss:	0.10 dB @ 1 GHz

## MECHANICAL

Mating	50 ohm snap-on coupling, per CECC 22220
Engagement forces	engagement 4.5 lbs (20N) max. disengagement 2.3 lbs (10N) min.
Connector affixment to cable	Braid and jacket: hex crimp.
Cable affixment to center contact	Solder
Contact captivation	All types, except as noted
Connector durability	500 mating and unmating cycles min.

## MATERIAL

Body, Metal Parts Finish	Brass per QQB-626 Nickel or Gold
Center contacts gold plated (30 u" gold)	Male: Brass per QQB626 Female: Beryllium copper per QQC 530 heat treated per MIL H 7199
Insulators	PTFE
Gasket	Silicone Rubber
Crimp ferrules	Seamless copper tubing alloy
Finish	Nickel or Gold

## ENVIRONMENTAL

Temperature range	-65°C to + 165°C
Thermal shock	MIL-STD-202 method 107 (test cond. B) except high temperatures @ 200°C
Vibration	MIL-STD-202 method 204, snap-on (test cond. B)
Shock	MIL-STD-202 method 213, snap-on (test cond. B)
Corrosion	MIL-STD-202 method 101 (test cond. B) 5% salt solution.

## PLUG

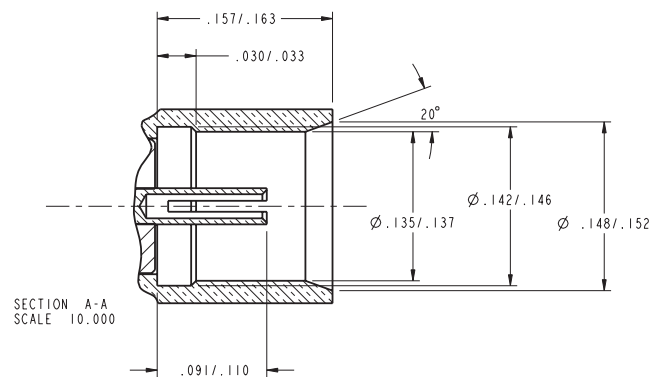

## JACK

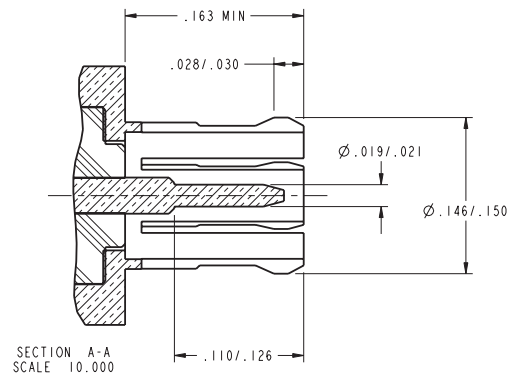

### NOTE:

1. I.D. to meet VSWR and contact resistance when mated with .48/.53mm diameter pin



# 75 Ohm Crimp Attachments for Flexible Cable

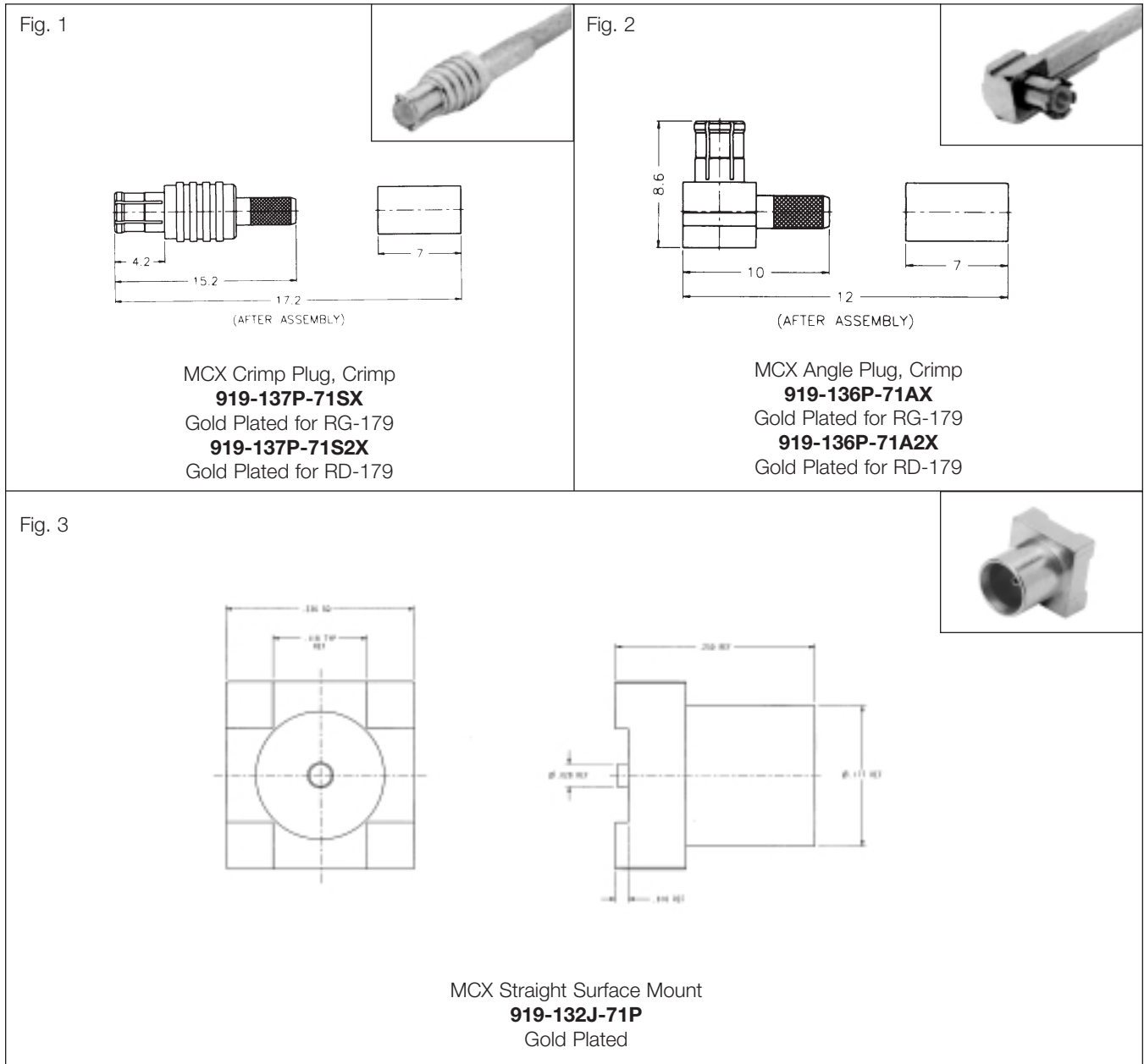

MCX

## 75 OHM MCX CABLE CONNECTORS

Cable RG-/U	Cable Attachment		CAI	Plt.	Ins.	Construction Notes	Amphenol Number	Fig.
	Outer	Inner						
RG-179	Crimp	Solder	C74	P11	D1	Gold Plated	<a href="#">919-137P-71SX</a>	1
RD-179	Crimp	Solder	C74	P11	D1	Gold Plated	<a href="#">919-137P-71S2X</a>	1
RG-179	Crimp	Solder	C77	P11	D1	Gold Plated	<a href="#">919-136P-71AX</a>	2
RD-179	Crimp	Solder	C77	P11	D1	Gold Plated	<a href="#">919-136P-71A2X</a>	2

## 75 OHM SURFACE MOUNT CONNECTOR

Cable RG-/U	Cable Attachment		CAI	Ins.	Construction Notes	Amphenol Number	Fig.
	Outer	Inner					
RG-316	Crimp	Solder	C74	D1	Gold Plated	<a href="#">919-132J-71P</a>	3



**Description**

The 1.0/2.3 series is a European design introduced in the 1990's. The compact design of the 1.0/2.3 permits dense connector packing; they are ideally suited to applications where space limitation is a factor.

Versions are available with threaded coupling mechanisms which provide positive mating or with a unique push-pull coupling system which allows quick installation. The Amphenol push-pull process is patented and ensures positive locking.

Amphenol 1.0/2.3 coaxial connectors are 50 ohm units operating from 0-10 GHz. This series complies with DIN 41626, DIN 47297, and NFC 93-571 international specifications.

**Features/Benefits**

- Push-Pull coupling with patented locking mechanism allows quick installation; will not disconnect during trouble shooting like competitor's products.
- Push-pull offers safe coupling. Locking mechanism will not vibrate loose as threaded connectors are prone to do.
- Push-pull coupling mechanism eliminates cross-threading problems eliminates field problems.
- Push-pull connectors can be more densely packed saving panel space in components that are shrinking in size.

**Application**

- Base Stations
- Cable Assemblies
- Components (Filters)
- Datacom
- Routers
- Switching Equipment
- Telecom



**1.0/2.3**

Specifications	26
Straight Cable Plugs & Jacks	27-28
Right Angle Cable Plugs & Jacks	29
PCB Jack Receptacles	30
PCB Press-Fit Jacks	31
4-Hole Flange Jacks	32
50 Ohm Terminator	33

### ELECTRICAL

Impedance	50 ohms
Frequency range	0-10 GHz
Voltage rating	250 Volts peak
Other	Contact resistance: Center contact 6 milliohm Outer contact 3 milliohm Insulation resistance: 10000 megohms

### ENVIRONMENTAL

Temperature range	- 40°C to +155°C
Connector Durability	500 matings

### MECHANICAL

Mating	Slide-On Push-Pull Threaded
Cable affixment (braid or jacket)	Hex crimp
Cable affixment (center conductor)	Crimp or solder
Captivated contacts	All crimps

### MATERIAL

Contacts	Male: Brass Female: (center and outer) Beryllium copper. Gold plated
Other metal parts	Brass, nickel plated
Insulators	Teflon
Crimp ferrule	Copper

NOTE: These characteristics are typical and may not apply to all connectors.



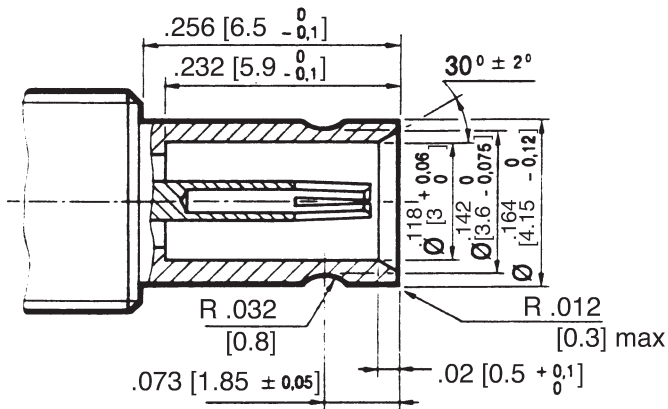

Plug

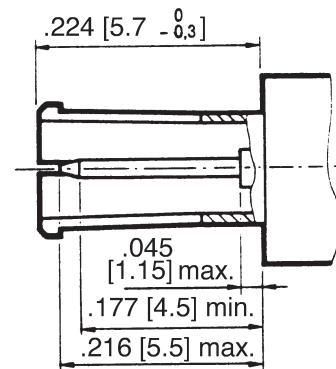

Jack

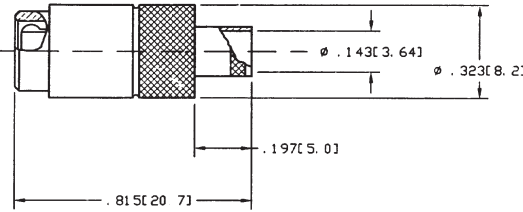

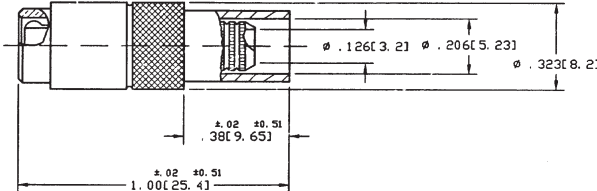
# Straight Cable Plugs for Semi-Rigid & Flexible Cable

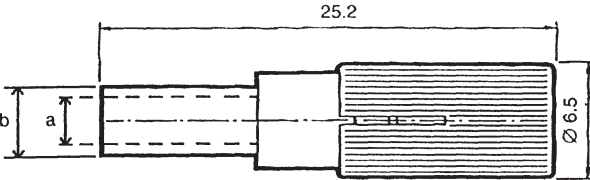
<p>Fig. 1</p>   <p>Straight Push-Pull Plugs Solder to Body <b>102-799-41</b> for .141 (3.6mm) SR RG 402 <b>102-799-85</b> for .085 (2.2mm) SR RG 405</p>	<p>Fig. 2</p>  
<p>Fig. 3</p>   <p>Straight Screw-On Plug <b>102-920-06</b> for RG-174, 188, 316</p>	<p>Straight Push-Pull Plugs Braid Crimp Solder Contact <b>102-799-04</b> for RG 58 <b>102-799-04DB</b> for RG 142 <b>102-799-16</b> for RG 174, 179, 188, 316 <b>102-799-16DB</b> for Double Braid RG 174, 316 <b>102-799-20</b> for LMR200 <b>102-799-48</b> for LMR 240</p>

1.0/2.3

## 1.0/2.3 CABLE PLUGS

Cable	Cable Attachment		Dimensions, inches (mm)		CAI	PLI	Ins.	Amphenol Number	Fig.
	Outer	Inner	a	b					
.141 S/R RG 402	Solder	Solder	.815(20.7)	.143(3.64)	C78	P37	D1	<a href="#">102-799-41</a>	1
.085 S/R RG 405	Solder	Solder	.815(20.7)	.090(2.3)	C78	P37	D1	<a href="#">102-799-85</a>	1
RG 58	Crimp	Crimp	.984(25.0)	.206(5.23)	C79	P37	D1	<a href="#">102-799-04</a>	2
RG 142B	Crimp	Solder	.984(25.0)	.216(5.5)	C79	P37	D1	<a href="#">102-799-04DB</a>	2
RG 174, 179, 187, 188, 316	Crimp	Crimp	.984(25.0)	.128(3.25)	C79	P37	D1	<a href="#">102-799-16</a>	2
RG 316 Double Braid	Crimp	Solder	.984(25.0)	.142(3.61)	C79	P37	D1	<a href="#">102-799-16DB</a>	2
LMR200	Crimp	Solder	.984(25.0)	.206(5.23)	C79	P37	D1	<a href="#">102-799-20</a>	2
LMR240	Crimp	Solder	1.38(35.0)	.261(6.63)	C79	P37	D1	<a href="#">102-799-48</a>	2
RG 174, 188, 316	Crimp	Crimp	.992(25.2)	.128(3.25)	C79	P37	D1	<a href="#">102-920-06</a>	3

• Accommodates cable diameter

# 1.0/2.3 Straight Jacks

<p>Fig. 1</p> <p>Straight Bulkhead Jack <b>102-913-06</b> for RG 174, 179, 316</p>		<p>Fig. 2</p> <p>Straight Bulkhead Jack <b>102-913-18</b> mini-coax</p>	
<p>Fig. 3</p> <p>Straight Bulkhead Jack <b>102-246-41</b> for SR .141 <b>102-246-85</b> for SR .085</p>		<p>Fig. 4</p> <p>Straight 4-Hole Flange Jack <b>102-243-41</b> for SR .141</p>	

## 1.0/2.3 CABLE PLUGS

Cable	Cable Attachment		Dimensions, inches (millimeters)				Amphenol Number	Fig.
	Outer	Inner	a	CAI	Pit	Ins.		
RG 174, 179, 316	Crimp	Solder	.127(3.25)	C81	P11	D1	<a href="#">102-913-06</a>	1
Mini Coax	Crimp	Solder	.098(2.50)	C81	P11	D1	<a href="#">102-913-18</a>	2
SR .141	Solder	Solder	.143(3.63)	C78	P11	D1	<a href="#">102-246-41</a>	3
SR .085	Solder	Solder	.090(2.28)	C78	P11	D1	<a href="#">102-246-85</a>	3
SR .141	Solder	Solder	.143(3.63)	C78	P11	D1	<a href="#">102-243-41</a>	4
RG 316 Double Braid	Crimp	Solder	.143(3.63)	C81	P11	D1	<a href="#">102-913-06DB</a>	1

# 1.0/2.3 Right Angle Cable Plugs & Jacks

**Fig. 1**

Push-Pull Angle Plugs

<p><b>102-799-118</b> Mini-Coax</p> <p><b>102-799-104</b> for RG-58</p> <p><b>102-799-116DB</b> for RD 316</p>	<p><b>102-799-104DB</b> for RG-55, 142</p> <p><b>102-799-185</b> for .085 2.2mm S/R RG-405</p> <p><b>102-799-141</b> for .141 3.6mm S/R RG-402</p> <p><b>102-799-116</b> for RG-316</p>
--	---

**Fig. 2**

Angle Jacks

<p><b>102-907-06</b> for RG 174, 179, 188, 316</p> <p><b>102-907-34</b> for L 910/34 RG 180</p>	
---	--

## 1.0/2.3 RIGHT ANGLE PLUGS & JACKS

Cable	Cable Attachment		Dimensions, inches (millimeters)					Amphenol Number	Fig.
	Outer	Inner	a	b	CAI	PLT	Ins.		
Mini-Coax	Crimp	Solder	.099(2.50)	1.00(25.5)	C80	P37	D1	<a href="#">102-799-118</a>	1
RG 58	Crimp	Solder	.205(5.23)	1.00(25.5)	C80	P37	D1	<a href="#">102-799-104</a>	1
RD 316	Crimp	Solder	.142(3.61)	1.00(25.5)	C80	P37	D1	<a href="#">102-799-116DB</a>	1
RG-55, 142	Crimp	Solder	.161(4.10)	.803(20.4)	C80	P37	D1	<a href="#">102-799-104DB</a>	1
RG 174, 179, 188, 316	Crimp	Solder	.128(3.25)	.803(20.4)	C80	P37	D1	<a href="#">102-907-06</a>	2
L 910/34 RG 180	Crimp	Solder	.161(4.10)	.803(20.4)	C80	P37	D1	<a href="#">102-907-34</a>	2
RG-405	Solder	Solder	.090(2.28)	.990(25.1)	C82	P37	D1	<a href="#">102-799-185</a>	1
RG-402	Solder	Solder	.143(3.63)	.990(25.1)	C82	P37	D1	<a href="#">102-799-141</a>	1
RG-316	Crimp	Solder	.128(3.25)	.990(25.1)	C80	P37	D1	<a href="#">102-799-116</a>	1

# 1.0/2.3 PCB Jack Receptacles

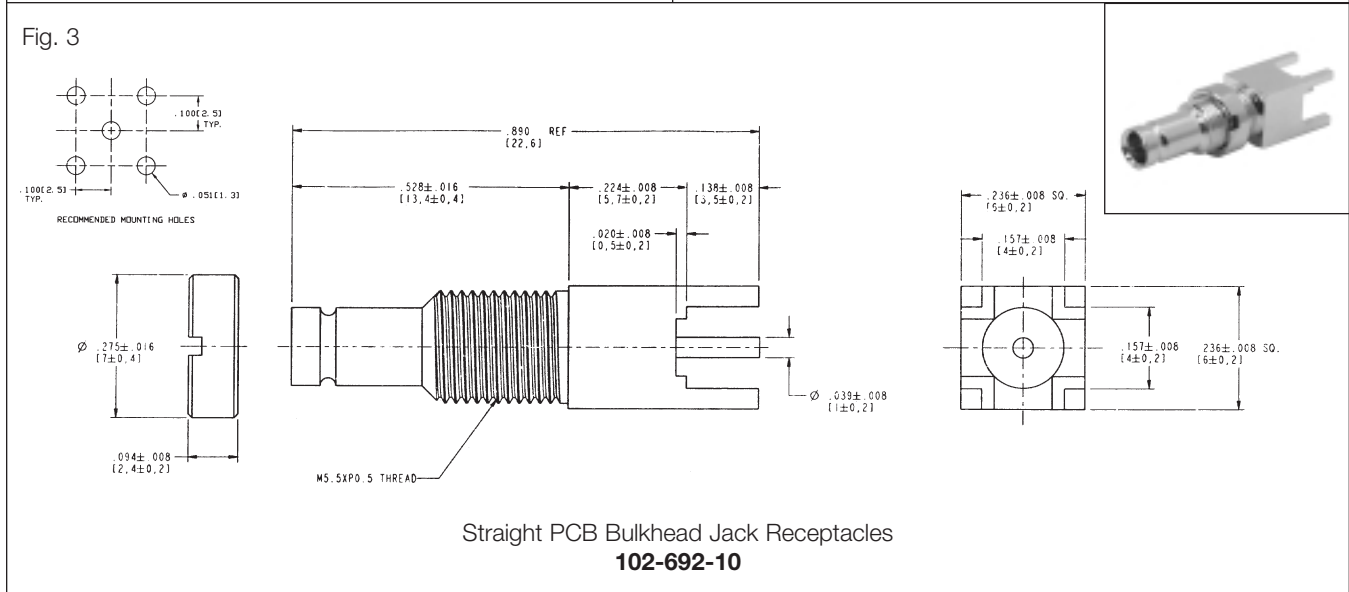
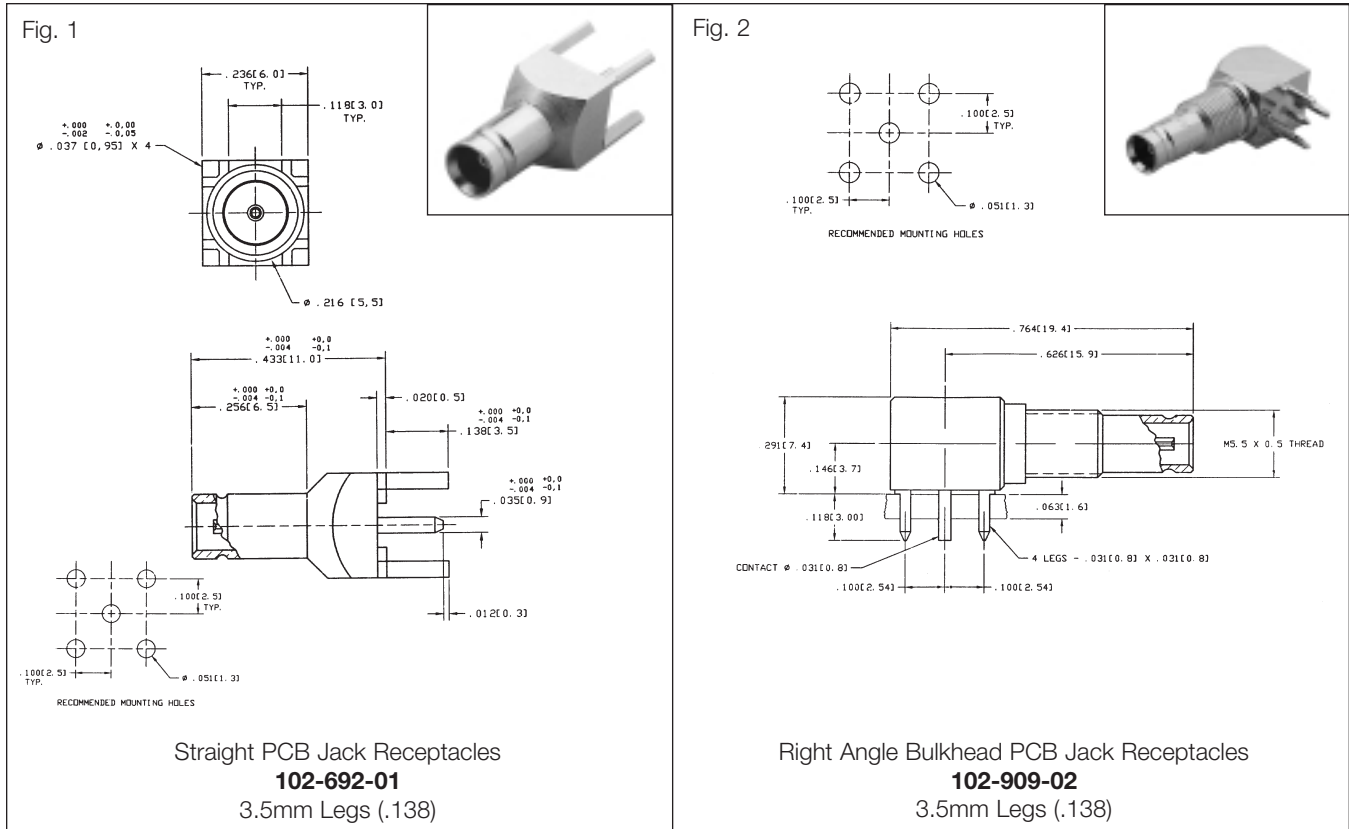

## 1.0/2.3 PCB JACK RECEPTACLES

Description	Terminal Type	Ins	Construction Notes	Amphenol Number	Fig
PCB Straight Jack Receptacle	Blunt Post	D1	Gold plated body	<a href="#">102-692-01</a>	1
PCB Straight Bulkhead Jack Receptacle	Blunt Post	D1	Gold plated body	<a href="#">102-692-10</a>	3
PCB Bulkhead Angle Jack Receptacle	Blunt Post	D1	Gold plated body	<a href="#">102-909-02</a>	2



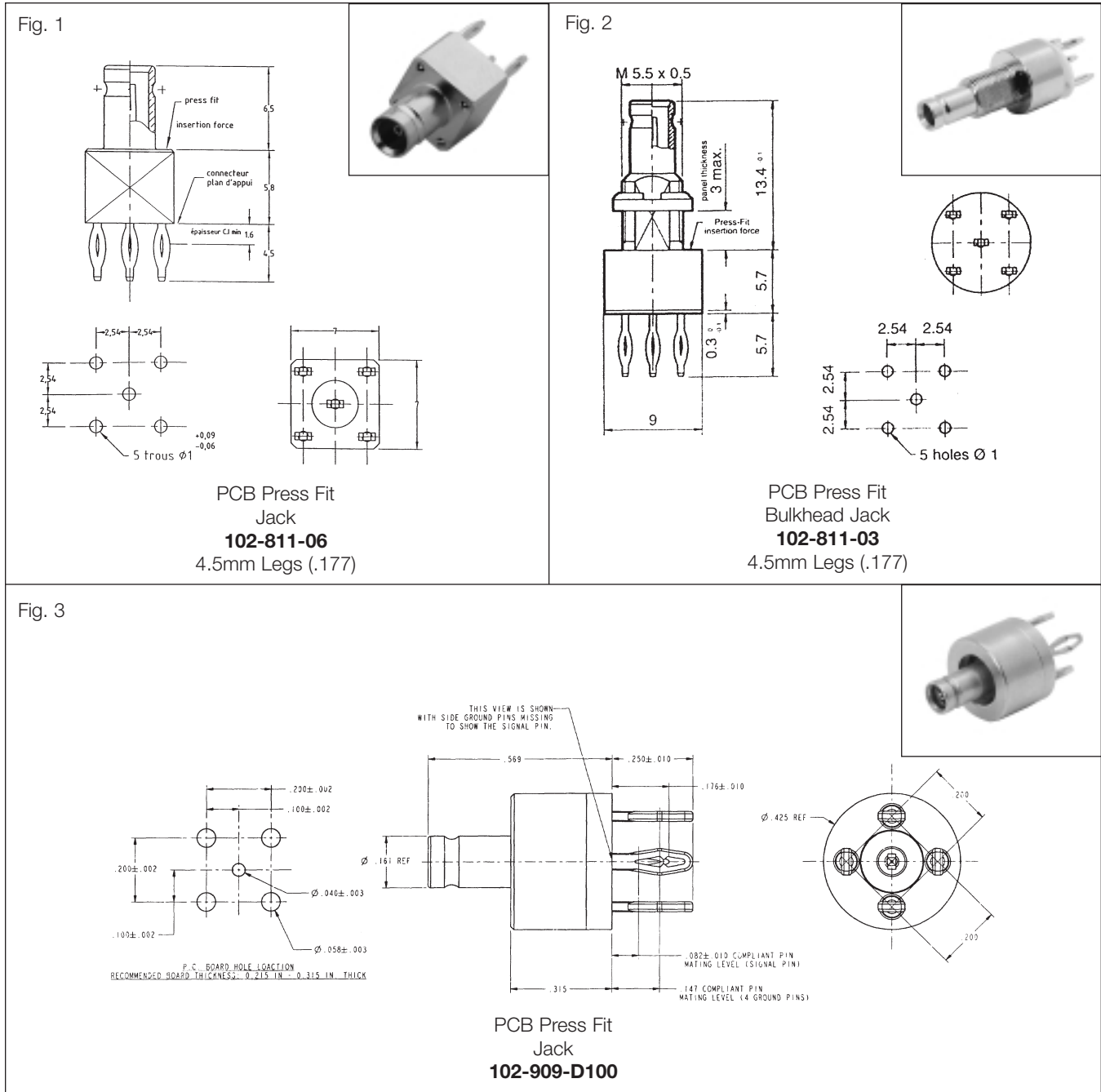

1.0/2.3

## 1.0/2.3 PCB PRESS FIT JACK

Description	Terminal Type	Ins	Construction Notes	Amphenol Number	Fig
PCB Press Fit Receptacle	Compliant Pin	D1	Gold plated body	<a href="#">102-811-06</a>	1
PCB Press Fit Bulkhead Receptacle	Compliant Pin	D1	Gold plated body	<a href="#">102-811-03</a>	2
PCB Press Fit Jack	Compliant Pin	D1	Gold plated body	<a href="#">102-909-D100</a>	3



# 1.0/2.3 50 Ohm Terminator

Fig. 1

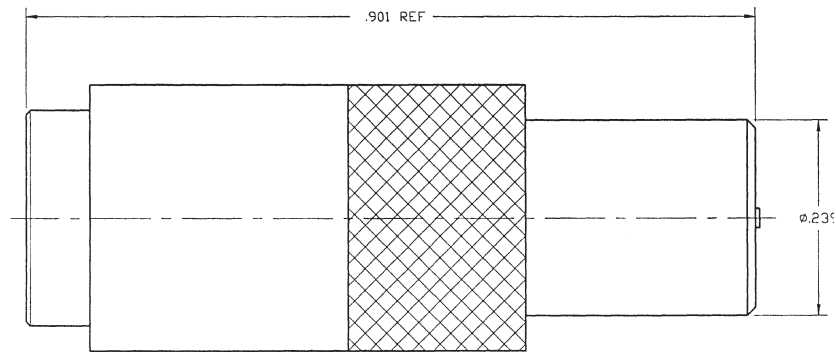

50 Ω Terminator  
102-799-050

1.0/2.3

## 50 Ohm Terminator

Description	F(GHz)	Power	VSWR	Ins	Construction Notes	Amphenol Number	Fig
50 Ω Terminator	O-4	1/4Watt	1.1 + .05 F (GHz)	D1	Push Pull Coupling	<a href="#">102-799-050</a>	1



**Description**

The SMB name derives from SubMiniature B (the second subminiature design). The SMB was developed in the 1960's.

SMB is a smaller version of the SMA with snap-on coupling.

Amphenol's SMB connectors conform to the requirements of MIL-C-39012 and their interface is in compliance with MIL-STD-348.

Available in 50 & 75 ohm impedance

SMB provides broadband capability through 4 GHz with a snap-on connector design and utilizes die cast components on non-critical areas to provide a low cost solution.

**Features and Benefits**

- Broadband performance with low reflection DC to 4 GHz provides low cost connector combined with high quality.
- Quick connect/disconnect snap-on mating reduces installation time.
- Availability in 50 Ohm, 75 Ohm & High Density 75 Ohm ensures customer a solution to specific applications.
- Various plating options: Nickel, Gold, Tin Lead. Also selective plating provides corrosion resistance finish as well as good solderability characteristics.
- SMB PCB slide-on plug and jack allows board to board mounting with a low insertion force. Ideal for mating a high number of connectors on a pair of PCBs.

**Application**

- Antennas
- Automotive (GPS)
- Base Stations
- Cable Assemblies
- Components
- Instrumentation
- PC/LAN
- Process Controls
- Radio Boards
- Surge Protection
- Telecom
- Test and Measurement
- Video Systems

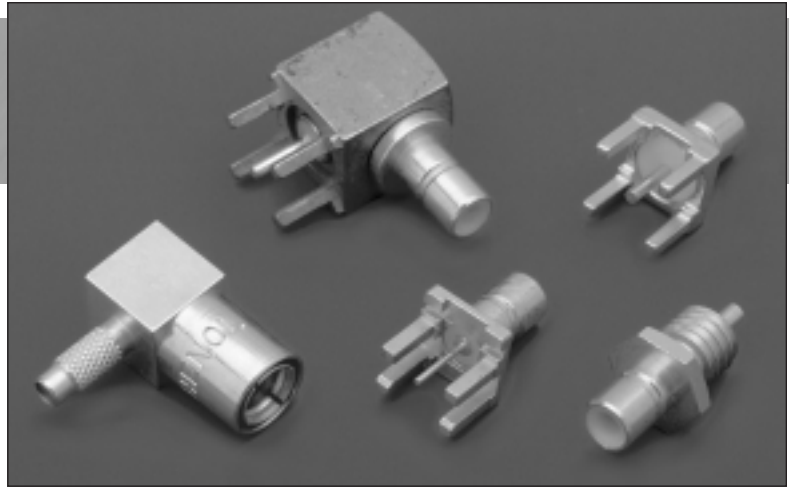

**50 ohm Coaxial Connectors**

Specifications	36
Plugs	37
Jacks	38
Bulkhead Receptacles	39-40
PCB Receptacles	41-43

**75 ohm Coaxial Connectors**

Specifications	44
Plugs, Jacks	45
Receptacles, PCB	46

**75 ohm High Density Coaxial Connectors**

Specifications	47
Plugs	48
PCB Receptacles	49

## ELECTRICAL

Impedance	50 ohms
Frequency range	0-4 GHz with low reflection; usable to 10.0 GHz.
Voltage rating for RG-188/U cables	Sea level: 335 volts 70,000 ft: 85 volts
Dielectric withstanding voltage	750 VRMS RG-196 type 1000 VRMS for RG-188 type
VSWR straight connectors rt. angle connectors	RG-196/U series 1.30 + .04 f (GHz) 1.45 + .06 f (GHz)
	RG-188/U series 1.25 + .04 f (GHz) 1.35 + .04 f (GHz)
Contact resistance	Center contact: initial, 6.0 milliohms; After environmental, 8.0  Outer contact: initial, 1.0 milliohms; After environmental, 1.5  Braid to body: initial, 1.0 milliohms; After environmental, N/A
Insulation resistance	1000 megohms min.
RF leakage	-55 dB min. @ 2 - 3 GHz
Insertion loss: straight connectors rt. angle connectors	0.30 dB @ 1.5 GHz
	0.60 dB @ 1.5 GHz

## MECHANICAL

Mating	50 ohm snap-on coupling, per MIL-STD-348
Engagement forces	Initial 14 lbs. max. engagement.  After 500 matings, 14 lbs. max engagement and disengagement.  2 lbs. min. disengagement.
Connector affixment to cable	Braid and jacket: hex crimp.
Cable affixment to center contact	Solder
Contact captivation	All types, except as noted
Cable retention	Equal to breaking strength of cable employed
Connector durability	500 mating and unmating cycles min.

## ENVIRONMENTAL

Temperature range	-65°C to + 165°C
Thermal shock	MIL-STD-202 method 107 (test cond. B) except high temp test @ + 200°C
Vibration	MIL-STD-202 method 204, snap-on (test cond. B) (15G's)
Shock	MIL-STD-202 method 213, snap-on (test cond. B) 75 G's @ 6 milliseconds 1/2 sine.
Corrosion	MIL-STD-202 method 101 (test cond. B) 5% salt solution.

## MATERIAL

Bodies	Brass per QQB-626 or zinc per ASTM B86-71, as specified, nickel (or gold) plated as listed
Center contacts	Female: beryllium copper, gold plated Male: brass or beryllium copper, gold plated
Outer contact	Nickel or gold plated as listed.
Crimp ferrules	Annealed copper alloy
Insulators	TFE

## PLUG

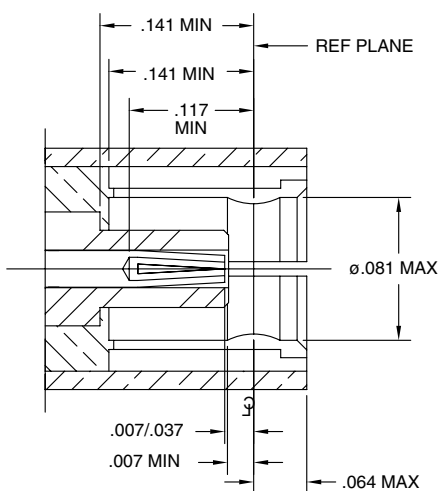

## JACK

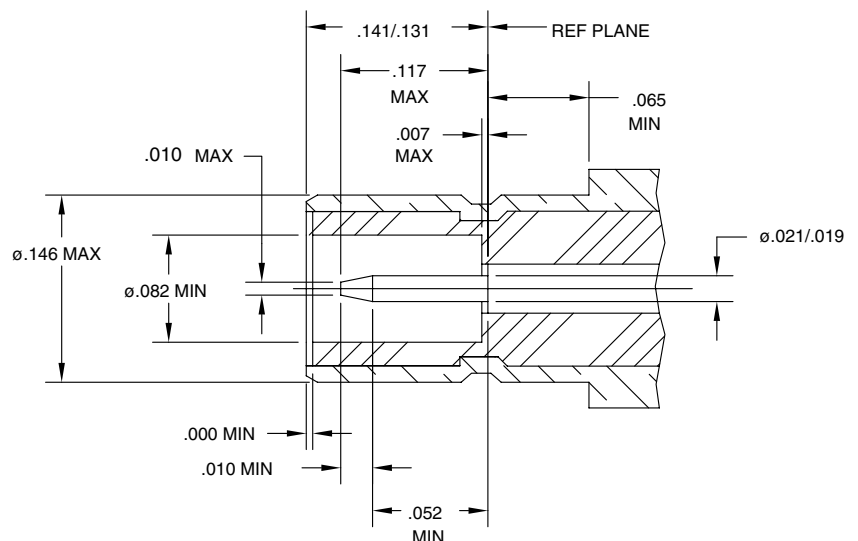

# SMB 50 ohm Coaxial Connectors



		<p>50Ω SMB Angle Plugs - Braid Crimp/Solder Female Contact</p> <table border="1"> <tr> <td rowspan="4">RG-174 179, 187, 188, 316</td> <td><b>903-289P-51A</b></td> <td>Gold Plated</td> </tr> <tr> <td><b>903-289P-51A2▲*</b></td> <td>Gold Plated</td> </tr> <tr> <td><b>903-367P-51A</b></td> <td>Nickel Plated</td> </tr> <tr> <td><b>903-367P-51A1</b></td> <td>Nickel Plt. Body, Gold Plt Outer Cont.</td> </tr> <tr> <td rowspan="4">RG-178, 196</td> <td><b>903-367P-51A2▲*</b></td> <td>Nickel Plated</td> </tr> <tr> <td><b>903-291P-51A</b></td> <td>Gold Plated</td> </tr> <tr> <td><b>903-291P-51A1▲*</b></td> <td>Gold Plated</td> </tr> <tr> <td><b>903-368P-51A</b></td> <td>Nickel Plated</td> </tr> <tr> <td rowspan="2">Dbl. Br. RG-316</td> <td><b>903-368P-51A1▲*</b></td> <td>Nickel Plated</td> </tr> <tr> <td><b>903-369P-51A</b></td> <td>Nickel Plated</td> </tr> <tr> <td colspan="2"></td> <td><b>903-369P-51A2*</b></td> <td>Nickel Plated</td> </tr> </table>		RG-174 179, 187, 188, 316	<b>903-289P-51A</b>	Gold Plated	<b>903-289P-51A2▲*</b>	Gold Plated	<b>903-367P-51A</b>	Nickel Plated	<b>903-367P-51A1</b>	Nickel Plt. Body, Gold Plt Outer Cont.	RG-178, 196	<b>903-367P-51A2▲*</b>	Nickel Plated	<b>903-291P-51A</b>	Gold Plated	<b>903-291P-51A1▲*</b>	Gold Plated	<b>903-368P-51A</b>	Nickel Plated	Dbl. Br. RG-316	<b>903-368P-51A1▲*</b>	Nickel Plated	<b>903-369P-51A</b>	Nickel Plated			<b>903-369P-51A2*</b>	Nickel Plated						
RG-174 179, 187, 188, 316	<b>903-289P-51A</b>	Gold Plated																																		
	<b>903-289P-51A2▲*</b>	Gold Plated																																		
	<b>903-367P-51A</b>	Nickel Plated																																		
	<b>903-367P-51A1</b>	Nickel Plt. Body, Gold Plt Outer Cont.																																		
RG-178, 196	<b>903-367P-51A2▲*</b>	Nickel Plated																																		
	<b>903-291P-51A</b>	Gold Plated																																		
	<b>903-291P-51A1▲*</b>	Gold Plated																																		
	<b>903-368P-51A</b>	Nickel Plated																																		
Dbl. Br. RG-316	<b>903-368P-51A1▲*</b>	Nickel Plated																																		
	<b>903-369P-51A</b>	Nickel Plated																																		
		<b>903-369P-51A2*</b>	Nickel Plated																																	
<p>50Ω SMB Plugs - Braid Crimp/Solder Female Contact</p> <table border="1"> <tr> <td rowspan="4">RG-174,179, 187,188, 316</td> <td><b>903-285P-51S</b></td> <td>Gold Plated</td> </tr> <tr> <td><b>903-508P-51S●</b></td> <td>Gold Plated</td> </tr> <tr> <td><b>903-370P-51S▲</b></td> <td>Nickel Plated</td> </tr> <tr> <td><b>903-577P-51S1*</b></td> <td>Nickel Plated</td> </tr> <tr> <td rowspan="4">RG-178,196</td> <td><b>903-577P-51S*</b></td> <td>Gold Plated</td> </tr> <tr> <td><b>903-287P-51S</b></td> <td>Gold Plated</td> </tr> <tr> <td><b>903-509P-51S●</b></td> <td>Gold Plated</td> </tr> <tr> <td><b>903-371P-51S▲</b></td> <td>Nickel Plated</td> </tr> <tr> <td rowspan="3">Dbl. Br. RG-316</td> <td><b>903-578P-51S*</b></td> <td>Gold Plated</td> </tr> <tr> <td><b>903-578P-51S1*</b></td> <td>Nickel Plated</td> </tr> <tr> <td><b>903-401P-51S</b></td> <td>Gold Plated</td> </tr> <tr> <td colspan="2"></td> <td><b>903-579P-51S*</b></td> <td>Gold Plated</td> </tr> <tr> <td colspan="2"></td> <td><b>903-579P-51S1*</b></td> <td>Nickel Plated</td> </tr> </table>		RG-174,179, 187,188, 316	<b>903-285P-51S</b>	Gold Plated	<b>903-508P-51S●</b>	Gold Plated	<b>903-370P-51S▲</b>	Nickel Plated	<b>903-577P-51S1*</b>	Nickel Plated	RG-178,196	<b>903-577P-51S*</b>	Gold Plated	<b>903-287P-51S</b>	Gold Plated	<b>903-509P-51S●</b>	Gold Plated	<b>903-371P-51S▲</b>	Nickel Plated	Dbl. Br. RG-316	<b>903-578P-51S*</b>	Gold Plated	<b>903-578P-51S1*</b>	Nickel Plated	<b>903-401P-51S</b>	Gold Plated			<b>903-579P-51S*</b>	Gold Plated			<b>903-579P-51S1*</b>	Nickel Plated		
RG-174,179, 187,188, 316	<b>903-285P-51S</b>		Gold Plated																																	
	<b>903-508P-51S●</b>		Gold Plated																																	
	<b>903-370P-51S▲</b>		Nickel Plated																																	
	<b>903-577P-51S1*</b>	Nickel Plated																																		
RG-178,196	<b>903-577P-51S*</b>	Gold Plated																																		
	<b>903-287P-51S</b>	Gold Plated																																		
	<b>903-509P-51S●</b>	Gold Plated																																		
	<b>903-371P-51S▲</b>	Nickel Plated																																		
Dbl. Br. RG-316	<b>903-578P-51S*</b>	Gold Plated																																		
	<b>903-578P-51S1*</b>	Nickel Plated																																		
	<b>903-401P-51S</b>	Gold Plated																																		
		<b>903-579P-51S*</b>	Gold Plated																																	
		<b>903-579P-51S1*</b>	Nickel Plated																																	
		<p>50Ω SMB Low Profile Angle Plugs, Braid Crimp/Solder Female Contact</p> <table border="1"> <tr> <td>RG-174,179, 187,188, 316</td> <td><b>903-429P-51A</b></td> <td>Gold Plated</td> </tr> </table>		RG-174,179, 187,188, 316	<b>903-429P-51A</b>	Gold Plated																														
RG-174,179, 187,188, 316	<b>903-429P-51A</b>	Gold Plated																																		

## 50 ohm SMB PLUGS & ANGLE PLUGS

Cable RG-/U	Connector Description	Cable Attachment		c Dia. In. (mm)	CAI	Pit.	Ins.	Notes	Amphenol Number	Fig.
		Outer	Inner							
RG-174,179,187, 188,316	Plug	Crimp	Solder	.128(3.3)‡	C60	P11	D1	Gold Plated Body	<a href="#">903-285P-51S</a>	1
				.128(3.3)‡	C62	P11	D1	Gold Plated Body	● <a href="#">903-508P-51S</a>	1A
				.128(3.3)‡	C60	P15	D1	Nickel Plated Body	▲ <a href="#">903-370P-51S</a>	1
				.128(3.3)‡	C60	P15	D1	Nickel Plated Body	* <a href="#">903-577P-51S1</a>	1
				.128(3.3)‡	C60	P15	D1	Gold Plated Body	* <a href="#">903-577P-51S</a>	1
	Angle Plug	Crimp	Solder	.128(3.3)‡	C61	P11	D1	Gold Plated Body	<a href="#">903-289P-51A</a>	2
				.128(3.3)‡	C61	P11	D1	Gold Plated Body	●▲* <a href="#">903-289P-51A2</a>	2
				.128(3.3)‡	C61	P15	D1	Nickel Plated Body	* <a href="#">903-367P-51A</a>	2
				.128(3.3)‡	C61	P15	D1	Nickel Plated Body	●▲* <a href="#">903-367P-51A2</a>	2
				.128(3.3)‡	C61	P15	D1	Nickel Plated Body ★	<a href="#">903-367P-51A1</a>	2
Low Profile Angle Plug	Crimp	Solder	.128(3.3)‡	C61	P26	D1	Nickel Plated Body ★	<a href="#">903-429P-51A</a>	3	
RG-178,196	Plug	Crimp	Solder	.100(2.5)‡	C60	P11	D1	Gold Plated Body	<a href="#">903-287P-51S</a>	1
				.100(2.5)‡	C62	P11	D1	Gold Plated Body	● <a href="#">903-509P-51S</a>	1A
				.100(2.5)‡	C60	P15	D1	Nickel Plated Body	<a href="#">903-371P-51S</a>	1
				.100(2.5)‡	C60	P15	D1	Gold Plated Body	* <a href="#">903-578P-51S</a>	1
				.100(2.5)‡	C60	P15	D1	Nickel Plated Body	* <a href="#">903-578P-51S1</a>	1
Angle Plug	Crimp	Solder	.100(2.5)‡	C61	P11	D1	Gold Plated Body	<a href="#">903-291P-51A</a>	2	
			.100(2.5)‡	C61	P11	D1	Gold Plated Body	●▲* <a href="#">903-291P-51A1</a>	2	
			.100(2.5)‡	C61	P15	D1	Nickel Plated Body	<a href="#">903-368P-51A</a>	2	
			.100(2.5)‡	C61	P15	D1	Nickel Plated Body	●▲* <a href="#">903-368P-51A1</a>	2	
			.100(2.5)‡	C61	P15	D1	Nickel Plated Body	●▲* <a href="#">903-368P-51A1</a>	2	
Dbl. Braid 316	Angle Plug	Crimp	Solder	.142(3.6)‡	C61	P22	D1	Nickel Plated Body	<a href="#">903-369P-51A</a>	2
				.142(3.6)‡	C61	P15	D1	Nickel Plated Body	● * <a href="#">903-369P-51A2</a>	2
	Plug	Crimp	Solder	.142(3.6)‡	C60	P11	D1	Gold Plated Body	<a href="#">903-401P-51S</a>	1
				.142(3.6)‡	C60	P11	D1	Gold Plated Body	* <a href="#">903-579P-51S</a>	1
				.142(3.6)‡	C60	P11	D1	Gold Plated Body	* <a href="#">903-579P-51S1</a>	1

‡ i.d. of outer crimp ferrule ★ Gold plated outer contact ▲ Distributor stocked \* Diecast outer body ● Commercial grade

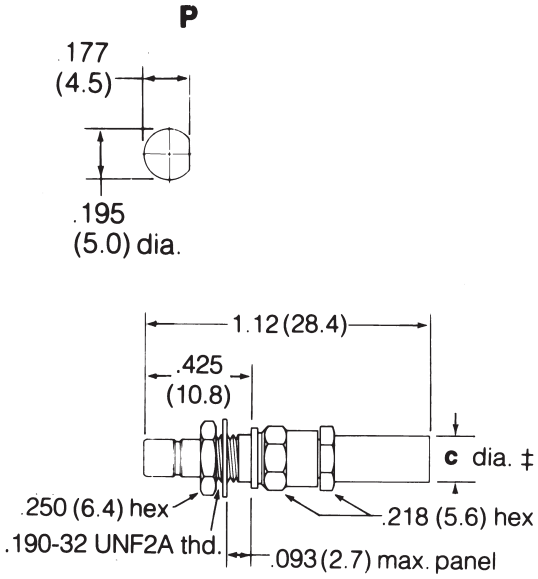
# SMB 50 ohm Coaxial Connectors

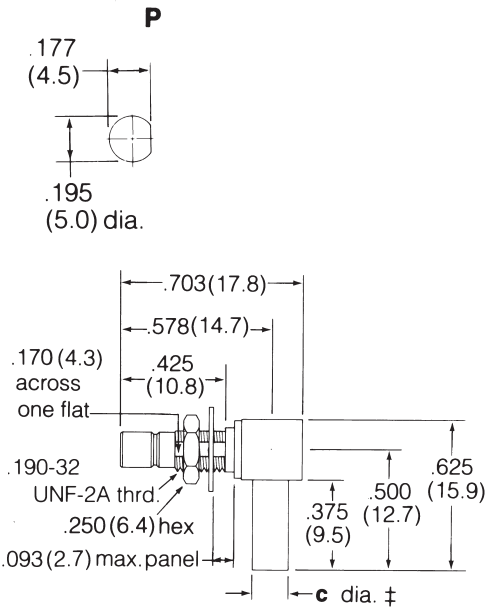
<p>Fig. 1</p>   <p>50Ω SMB Bulkhead Jacks Braid Crimp/Solder Male Contact</p>		<p>Fig. 2</p>   <p>50Ω SMB Angle Bulkhead Jacks Braid Crimp/Solder Male Contact</p>	
<p>RG-174,179, 187,188, 316</p>	<p><b>903-505J-51S</b> ▲● Gold Plated</p>	<p>RG-174,179, 187,188, 316</p>	<p><b>903-422J-51A</b> Gold Plated</p>
<p>Dbl. Shield 316</p>	<p><b>903-505J-51S1</b> ▲● Gold Plated</p>	<p>Dbl. Shield 316</p>	<p><b>903-422J-51A2</b> Gold Plated</p>

## 50 ohm SMB BULKHEAD & ANGLE BULKHEAD JACKS

Cable RG-/U	Connector Description	Cable Attachment		c Dia. In. (mm)	MTG Hole	CAI	Plt.	Ins.	Notes	Amphenol Number	Fig.
		Outer	Inner								
RG-174,179,187, 188,316	Bulkhead Jack	Crimp	Solder	.128(3.3)‡	P	C60	P15	D1	Gold Plated Body	▲● 903-505J-51S	1
	Angle Bulkhead Jack	Crimp	Solder	.128(3.3)‡	P	C61	P11	D1	Gold plated Body	903-422J-51A	2
Dbl. Shield 316	Bulkhead Jack	Crimp	Solder	.142(3.6)‡	P	C60	P15	D1	Gold Plated Body	▲● 903-505J-51S1	1
	Bulkhead Jack	Crimp	Solder	.142(3.6)‡	P	C61	P15	D1	Gold Plated Body	903-422J-51A2	2

▲ Distributor stocked      ● Commercial grade



# SMB 50 ohm Bulkhead Receptacles

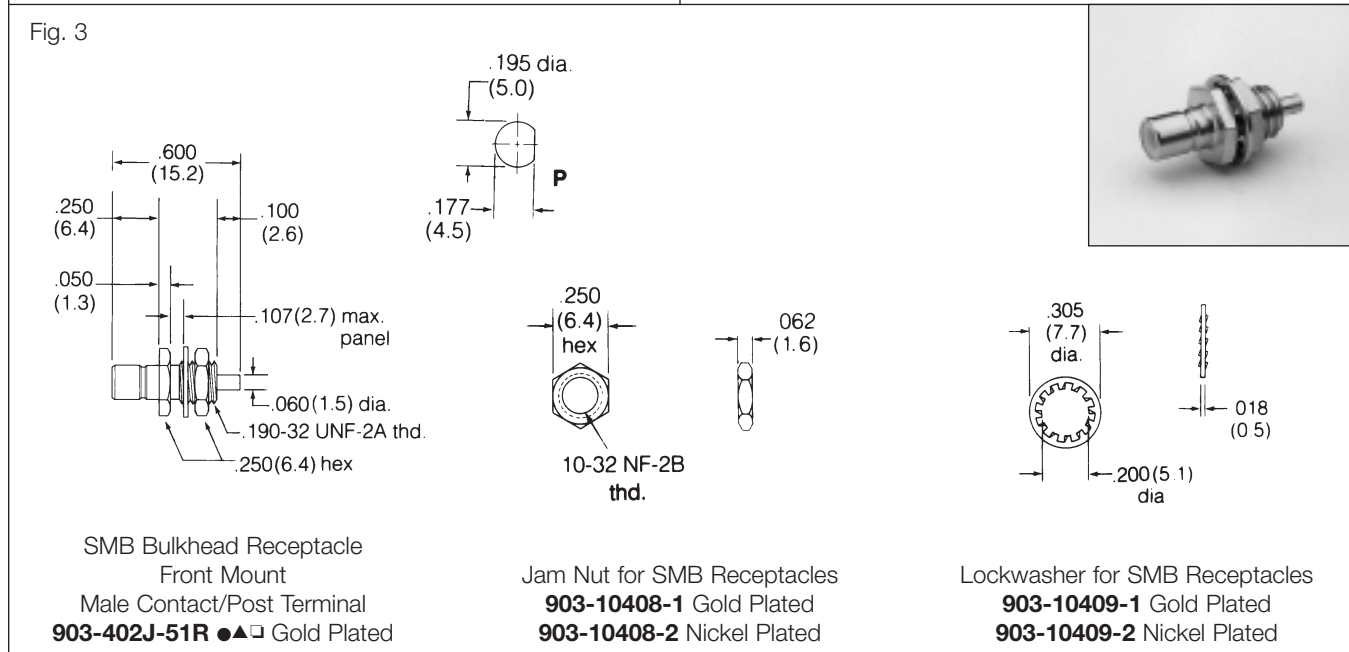
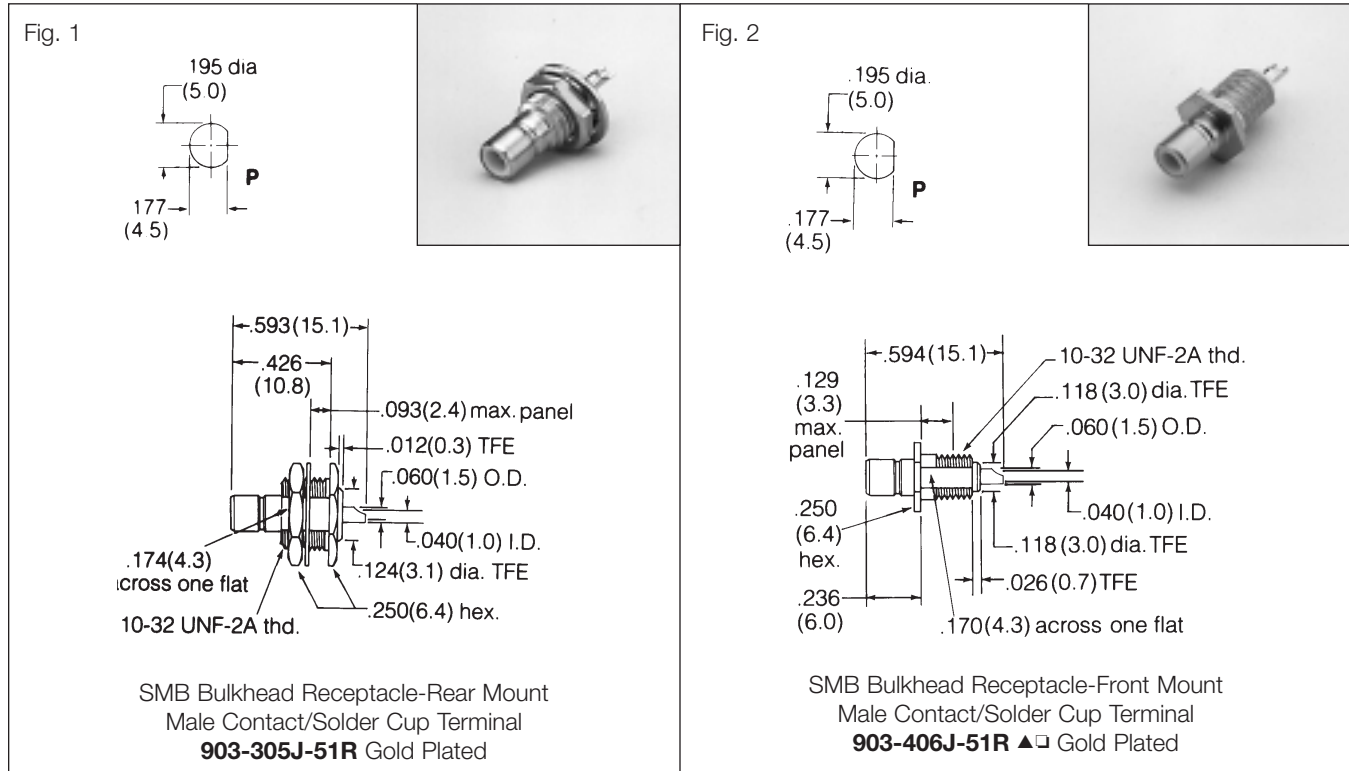

## 50 ohm SMB BULKHEAD JACK RECEPTACLES & ACCESSORIES – captive male contacts

Connector Description	Terminal Type	MTG Hole	Plt.	Ins	Construction Notes	Amphenol Number	Fig.
Bulkhead Jack Receptacle, Rear Mount	Solder Cup	P	P9	D1	Gold Plated Body	<b>903-305J-51R</b>	1
Bulkhead Jack Receptacle, Front Mount	Solder Cup	P	P11	D1	Gold Plated Body	▲ □ <b>903-406J-51R</b>	2
Bulkhead Jack Receptacle, Front Mount	Blunt Post	P	P9	D1	Gold Plated Body	● ▲ □ <b>903-402J-51R</b>	3
Jam Nut	—	—	—	—	See Fig. 3	<b>903-10408-1, -2</b>	3
Lockwasher	—	—	—	—	See Fig. 3	<b>903-10409-1, -2</b>	3

▲ Distributor stocked □ Jam Nut and Lockwasher sold separately. ● Commercial grade

# SMB 50 ohm Bulkhead Receptacles

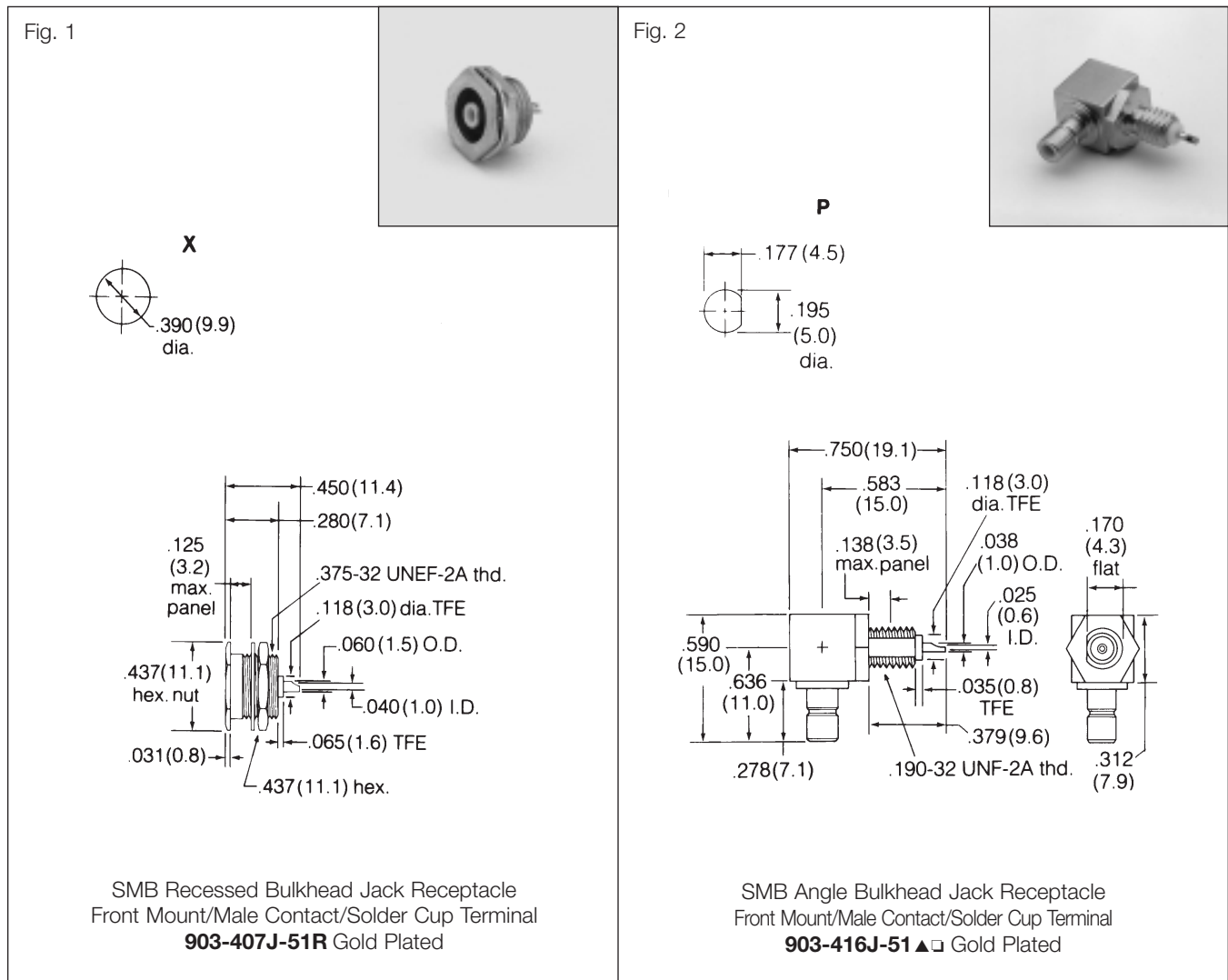

## 50 ohm SMB BULKHEAD JACK RECEPTACLES – captive male contacts

Connector Description	Terminal Type	MTG Hole	Plt.	Ins	Construction Notes	Amphenol Number	Fig.
Recessed Bulkhead Jack Receptacle, Front Mount	Solder Cup	X	P11	D1	Gold Plated Body	<b>903-407J-51R</b>	1
Angle Bulkhead Jack Receptacle, Front Mount	Solder Cup	P	P11	D1	Gold Plated Body	▲□ <b>903-416J-51R</b>	2

▲ Distributor stocked

□ Jam Nut and Lockwasher sold separately

# SMB 50 ohm PCB Receptacles

Fig. 1

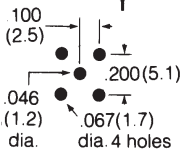
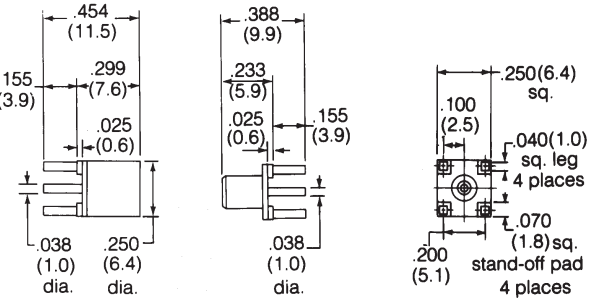
SMB PCB Slide-on Board-to-Board Interconnect for .360"(9mm) Bd. Spacing  
 Plug: **903-410P-53P** Gold Plated  
 Jack: **903-409J-53P** Gold Plated

Fig. 2



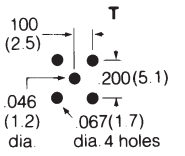
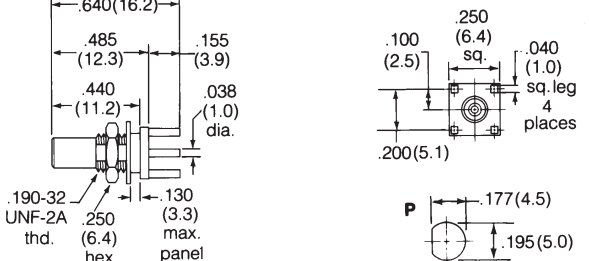

SMB PCB Bulkhead Jack Receptacle Male Contact/Post Terminal/Four Legs  
**903-375J-53P** Nickel Plated

## 50 ohm SMB BULKHEAD JACK AND PRINTED CIRCUIT RECEPTACLES – captive male contacts

Connector Description	Terminal Type	MTG Hole	Plt.	Ins	Construction Notes	Amphenol Number	Fig.
PCB Slide-on Board-to-Board Interconnect for .360"(9mm) Bd. Spacing/Four Legs	Blunt Post	T	P9	D1	Plug/Gold Plated	<b>903-410P-53P</b>	1
					Jack/Gold Plated	<b>903-409J-53P</b>	
PCB Bulkhead Jack Receptacle/,Four Legs	Blunt Post	T/P	P6	D1	Nickel Body/No Stand-off Pads	<b>903-375J-53P</b>	2

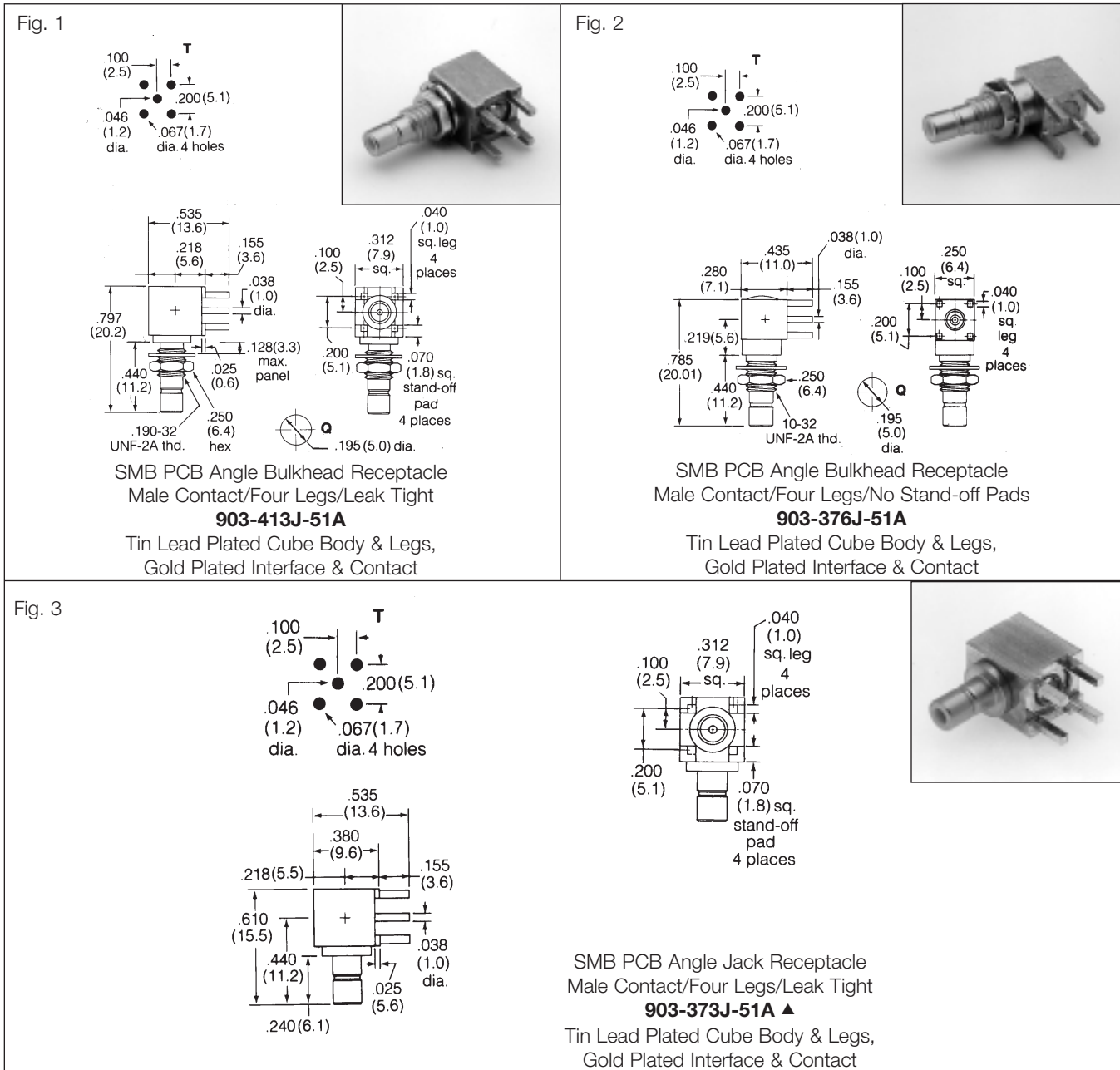
# SMB 50 ohm PCB Receptacles



## 50 ohm SMB BULKHEAD JACK AND PRINTED CIRCUIT RECEPTACLES – captive male contacts

Connector Description	Terminal Type	MTG Hole	Plt.	Ins	Construction Notes	Amphenol Number	Fig.
PCB Angle Bulkhead Jack Receptacle, Four Legs/Leak Tight	Blunt Post	T/Q	P16	D1	Tin Lead Plt. Cube Body & Legs Gold Plt. Interface & Contact	<a href="#">903-413J-51A</a>	1
PCB Angle Bulkhead Jack Receptacle, Four Legs/No Stand-off Pads	Blunt Post	T/Q	P16	D1	Tin Lead Plt. Cube Body & Legs Gold Plt. Interface & Contact	<a href="#">903-376J-51A</a>	2
PCB Angle Jack Receptacle Four Legs/Leak Tight	Blunt Post	T	P16	D1	Tin Lead Plt. Cube Body & Legs Gold Plt. Interface & Contact	<b>▲ 903-373J-51A</b>	3

▲ Distributor stocked      ● Commercial grade

# SMB 50 ohm PCB Receptacles

<p>Fig. 1</p> <p>SMB PCB Receptacle Jack Post Terminal/Four Legs <b>903-415J-51P</b> Gold Plated <b>903-499J-51P3*</b> Tin Plated Body &amp; Legs <b>903-499J-51P2▲*</b> Gold Plated</p>	<p>Fig. 2</p> <p>50Ω SMB PCB End Mount Jack Receptacle Male Contact/Blunt Post Terminal <b>903-518J-51P</b> Gold Plated Gold Plated Contact</p>
<p>Fig. 3</p> <p>SMB PCB Jack Receptacle Board Lock <b>903-515J-51P</b> Tin Lead Plt Body, Gold Plated Contact</p>	<p>Fig. 4</p> <p>SMB PCB Receptacle Jack Board Lock <b>903-499J-51P▲*</b> Gold Plated <b>903-499J-51P1*</b> Nickel Plated</p>

## 50 ohm SMB PRINTED CIRCUIT RECEPTACLES

Connector Description	Terminal Type	MTG Hole	Plt.	Ins	Construction Notes	Amphenol Number	Fig.
PCB Jack Receptacle/Four Legs	Blunt Post	T	P11	D1	Gold Plated Body	<b>903-415J-51P</b>	1
					Gold Plated Body	▲* <b>903-499J-51P2</b>	
			Tin Plated Body, Gold Plt. contact		* <b>903-499J-51P3</b>		
PCB Bulkhead Jack Receptacle/Four Legs	Blunt Post	T	P9	D1	Gold Plt. Body	<b>903-518J-51P</b>	2
PCB Bulkhead Jack Receptacle/Four Legs	Blunt Post	T	P9	D1	Tin Lead Plt Body, Gold Plt. contact	<b>903-515J-51P</b>	3
PCB Bulkhead Jack Receptacle	Board Lock	T	P11	D1	Gold Plated Body	▲* <b>903-499J-51P</b>	4
PCB Bulkhead Jack Receptacle	Board Lock	T	P11	D1	Nickel Plated Body	* <b>903-499J-51P1</b>	

▲ Distributor stocked \* Die cast outer body



Amphenol standard 75 ohm SMB 903 series connectors are constructed in accordance with the requirements of MIL-C-39012 and their interface is in compliance with MIL-STD-348. These subminiature units feature positive lock mating as well as snap-on mating faces.

They are available in a variety of configurations and styles. This series has broadband performance with low reflection.

### MATERIAL

Bodies	Brass per QQB-626, as specified, nickel (or gold) plated as listed
Center contacts	Female: beryllium copper, gold plated Male: brass or beryllium copper, gold plated
Outer contact	Nickel or gold plated as listed.
Crimp ferrules	Annealed copper alloy
Insulators	TFE

### SPECIFICATIONS

#### ELECTRICAL

Impedance	75 ohms
Frequency range	0-4 GHz with low reflection; usable to 10.0 GHz.
Voltage rating for RG-188/U cables	Sea level: 335 volts 70,000 ft: 85 volts
Dielectric withstanding voltage	1,000 VRMS
RF high potential withstanding voltage	RG-195/U series 500 VRMS
Corona level	RG-195/U series 400 min. volts @ 70K ft.
VSWR straight connectors	RG-196/U series 1.30 + .04 f (GHz) RG-188/U series 1.25 + .04 f (GHz)
right angle connectors	RG-196/U series 1.45 + .06 f (GHz) RG-188/U series 1.35 + .04 f (GHz)
Contact resistance	Center contact: initial, 6.0 milliohms; After environmental, 8.0 Outer contact: initial, 1.0 milliohms; After environmental, 1.5 Braid to body: initial, 1.0 milliohms; After environmental, N/A
Insulation resistance:	1000 megohms min.
RF leakage	-55 dB min. @ 2 - 3 GHz
Insertion loss: straight	0.30 dB @ 1.5 GHz
right angle	0.60 dB @ 1.5 GHz

\* These characteristics are typical and may not apply to all connectors.

This series is also called SMZ.

#### MECHANICAL

Mating	75 ohm snap-on coupling, per MIL-STD-348
Engagement forces	Initial 14 lbs. max. engagement. After 500 matings, 14 lbs. max engagement and disengagement. 2 lbs. min. disengagement.
Connector affixment to cable	Braid and jacket: hex crimp.
Cable affixment to center contact	Solder
Contact captivation	All types, except as noted
Cable retention	Equal to breaking strength of cable employed
Connector durability	500 mating and unmating cycles min.

#### ENVIRONMENTAL

Temperature range	-65°C to + 165°C
Thermal shock	MIL-STD-202 method 107 (test cond. B) except high temp test @ + 200°C
Vibration	MIL-STD-202 method 204, snap-on (test cond. B) (15G's)
Shock	MIL-STD-202 method 213, snap-on (test cond. B) 75 G's @ 6 milliseconds 1/2 sine.
Corrosion	MIL-STD-202 method 101 (test cond. B) 5% salt solution.

#### PLUG

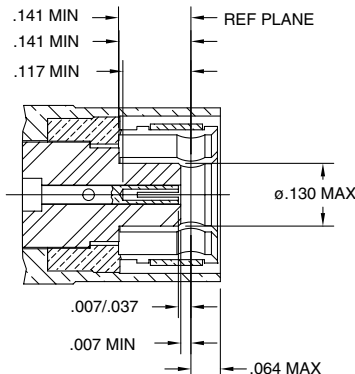

#### JACK

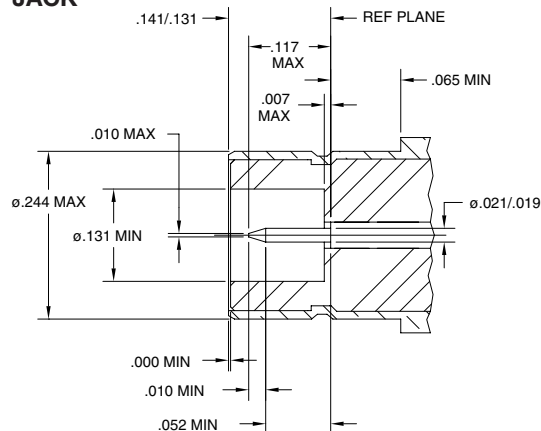

<p>Fig. 1</p> <p>Fig. 1A</p> <p><b>75Ω SMB Plug</b> Braid Crimp/Solder Female Contact <b>903-152P-71S7</b> Positive Lock for 735A Cable <b>903-152P-71S</b> Positive Lock for RG-180, 195 Gold Plated Body, Nickel Plt. Cpl. Ring <b>903-152P-71S3</b> Positive Lock for RG-179 Gold Plated Body, Nickel Plt. Cpl. Ring <b>903-574P-71S</b> Positive Lock for RG-179 <b>903-575P-71S</b> Positive Lock for RD-179</p>	<p>Fig. 2</p> <p>Fig. 1A</p> <p><b>75Ω SMB Plug</b> Braid Crimp/Solder Female Contact/Gold Plt. <b>903-502P-71S</b> for RG-179, Nickel Plated Body</p>
<p>Fig. 3</p> <p>Fig. 3</p> <p><b>75Ω SMB Angle Plug</b> Braid Crimp/Solder Female Contact <b>903-495P-71A</b> Positive Lock for Belden 1694A RG-6 Type, Gold Plated Body, Nickel Plt. Cpl. Ring</p>	<p>Fig. 4</p> <p>Fig. 4</p> <p><b>75Ω SMB Bulkhead Jack</b> Braid Crimp/Solder Male Contact/Gold Plated <b>903-108J-71S</b> for RG-179</p>

## 75 ohm SMB PLUGS, ANGLE PLUGS & BULKHEAD JACKS

Cable RG-/U	Connector Description	Cable Attachment		c Dia In. (mm)	MTG Hole	CAI	Plt.	Ins.	Notes	Amphenol Number	Fig.
		Outer	Inner								
RG-179	Bulkhead Jack	Crimp	Solder	.128(3.3)‡	R	C60	P9	D1	Gold Plated Body	<b>903-108J-71S</b>	4
	Plug (Positive Lock)	Crimp	Solder	.128 (3.3)	—	C60	P9	D1	Nickel Plt coupling Ring	<b>903-152P-71S3</b>	1
	Plug (Positive Lock)	Crimp	Solder	.128 (3.3)	—	C60	P9	D1	Nickel Plt coupling Ring	<b>903-574P-71S</b>	1
RD-179	Plug (Positive Lock)	Crimp	Solder	.128 (3.3)	—	C60	P9	D1	Nickel Plt coupling Ring	<b>903-575P-71S</b>	1
RG-174, 179, 187, 188, 316	Plug	Crimp	Solder	.128(3.3)‡	—	C60	PCF	D1	Nickel Plated Body Nickel Plt Coupling Ring	<b>903-502P-71S</b>	2
RG-180, 195	Plug (Positive Lock)	Crimp	Solder	.180(4.6)‡	—	C60	PCF	D1	Gold Plated Body Nickel Plt Coupling Ring	<b>903-152P-71S</b>	1
Amphenol 621-4460-75	Angle Plug (Positive Lock)	Crimp	Solder	.300(7.6)‡	—	C61	PCF	D1	Gold Plated Body	<b>903-495P-71A</b>	3
735A	Plug (Positive Lock)	Crimp	Solder	.175(4.4)	—	C60	P9	D1	Gold Plated Body	<b>903-152P-71S7</b>	1

‡ i.d. of outer crimp ferrule

# SMB 75 ohm Coaxial Connectors

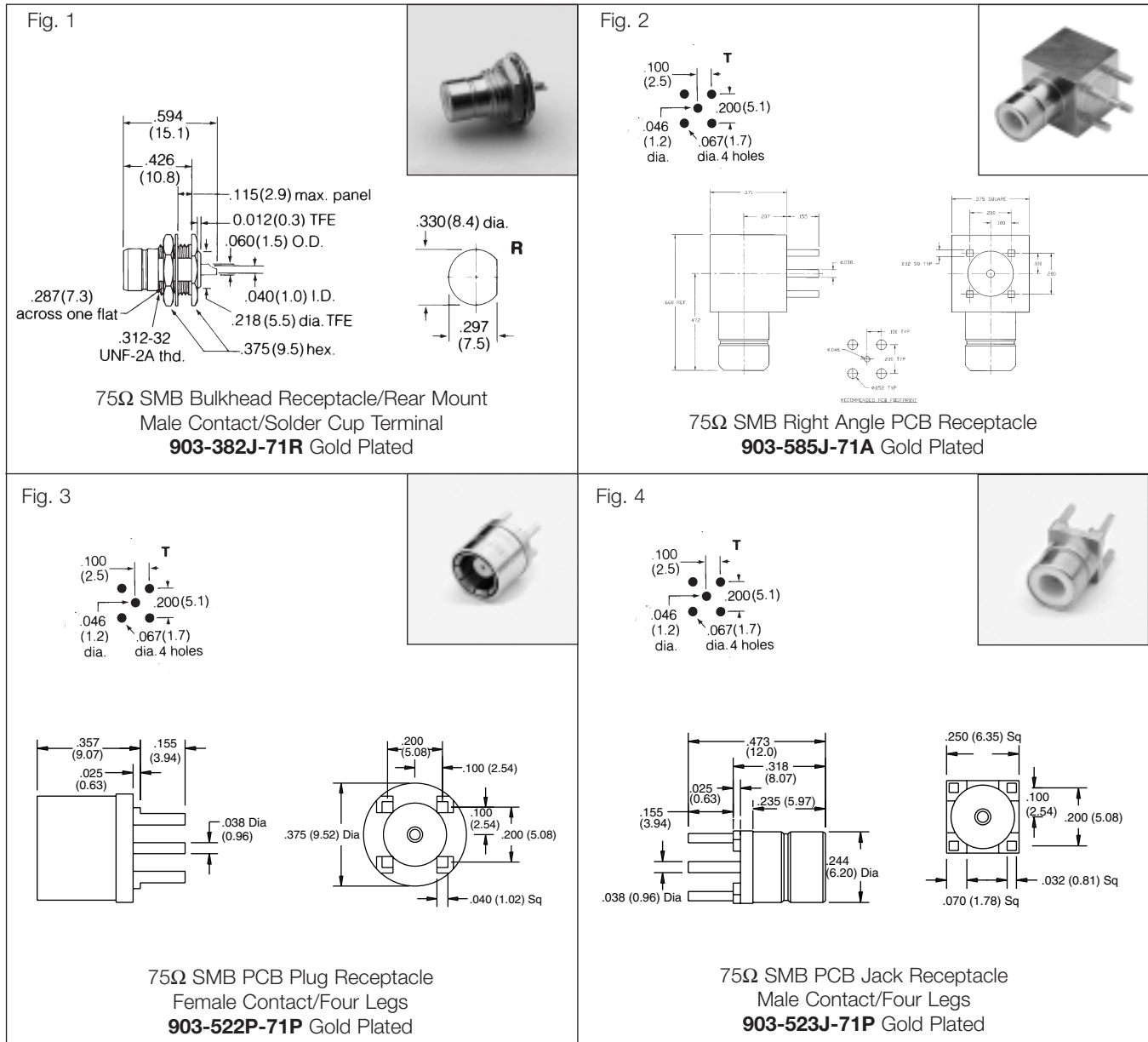

## 75 ohm SMB BULKHEAD & PRINTED CIRCUIT BOARD RECEPTACLES

Connector Description	Terminal Type	MTG Hole	Plt.	Ins	Construction Notes	Amphenol Number	Fig.
Bulkhead Jack Receptacle, Rear Mount	Solder Cup	R	P11	D1	Gold Plated/Captive Contact	<a href="#">903-382J-71R</a>	1
PCB Plug Receptacle/Four Legs	Blunt Post	T	P11	D1	Gold Plated/Captive Contact	<a href="#">903-522P-71P</a>	3
PCB Jack Receptacle/Four Legs	Blunt Post	T	P11	D1	Gold Plated/Captive Contact	<a href="#">903-523J-71P</a>	4
PCB R/A Jack Receptacle/Four Legs	Blunt Post	T	P11	D1	Gold Plated/Captive Contact	<a href="#">903-585J-71A</a>	2



# 75 ohm High Density Coaxial Connectors

Amphenol high density 75 ohm 903 Series SMB connectors conform to the requirements of MIL-C-39012 and the interface is in compliance with MIL-STD-348.

## Features/Benefits

- Broadband capability through 4 GHz combines with compact, space saving design.
- Can easily be identified by their red Teflon insulators.
- Guided entry sleeve for positive mating.
- Closed entry contact to prevent "slide-by".
- Full range of high density SMB connector configurations is available, including end launch, printed circuit board and cable connectors.
- Series gives design engineers options in applications where physical space is limited.



## SPECIFICATIONS

### ELECTRICAL

Impedance	75 ohms
Frequency range	0-4 GHz with low reflection
Voltage rating for RG-188/U cables	Sea level: 335 volts 70,000 ft: 85 volts
Dielectric withstanding voltage	750 VRMS, RG-196 type 1000 VRMS, RG-188 type
VSWR straight right angle connectors	735A type 1.25 + .04 f (GHz) 1.35 + .04 f (GHz)
Contact resistance	Center contact: initial, 6.0 milliohms; After environmental, 8.0  Outer contact: initial, 1.0 milliohms; After environmental, 1.5  Braid to body: initial, 1.0 milliohms; After environmental, N/A
Insulation resistance:	1000 megohms min.
RF leakage	-55 dB min. @ 2 - 3 GHz
Insertion loss: straight rt. angle	0.30 dB @ 1.5 GHz 0.60 dB @ 1.5 GHz

### MATERIAL

Bodies	Brass per QQB-626 or zinc per ASTM B86-71, as specified, nickel (or gold) plated as listed
Center contacts	beryllium copper, gold plated
Outer contact	Nickel or gold plated as listed.
Crimp ferrules	Annealed copper alloy
Insulators	TFE - Red for I.D.

### MECHANICAL

Mating	75 ohm snap-on coupling, per MIL-STD-348
Engagement forces	Initial 14 lbs. max. engagement. After 500 matings, 14 lbs. max engagement and disengagement. 2 lbs. min. disengagement.
Connector affixment to cable	Braid and jacket: hex crimp.
Cable affixment to center contact	Solder or crimp
Contact captivation	All types, except as noted
Cable retention	Equal to breaking strength of cable employed
Connector durability	500 mating and unmating cycles min.

### ENVIRONMENTAL

Temperature range	-65°C to + 165°C
Thermal shock	MIL-STD-202 method 107 (test cond. B) except high temp test @ + 200°C
Vibration	MIL-STD-202 method 204, snap-on (test cond. B) (15G's)
Shock	MIL-STD-202 method 213, snap-on (test cond. B) 75 G's @ 6 milliseconds 1/2 sine.
Corrosion	MIL-STD-202 method 101 (test cond. B) 5% salt solution.

\* These characteristics are typical and may not apply to all connectors.

### PLUG

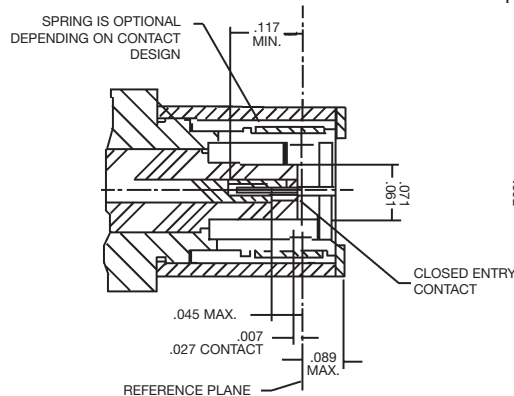

### JACK

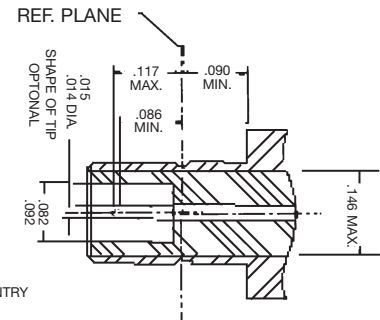

# SMB 75 ohm High Density Coaxial Connectors

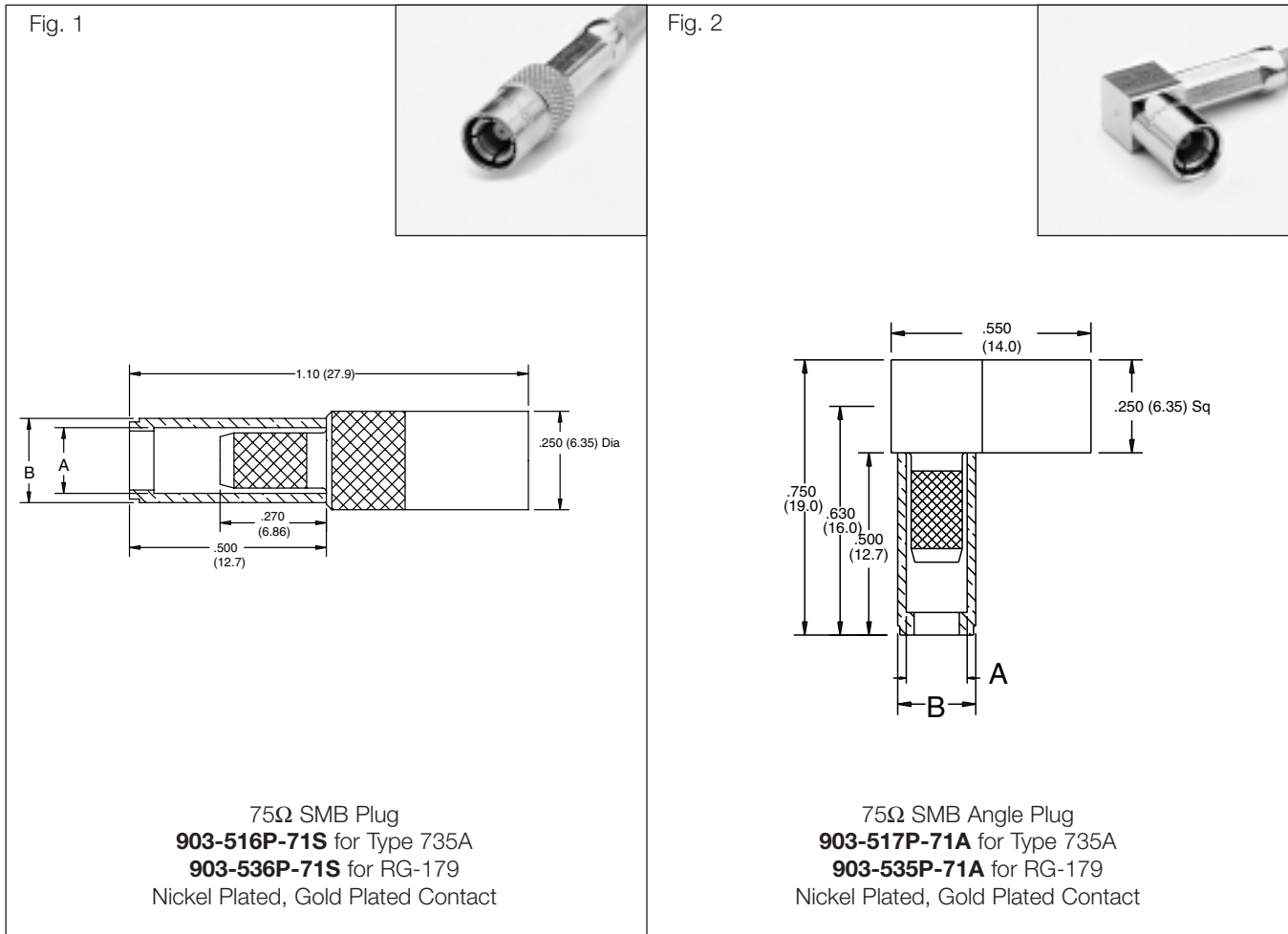

## 75 ohm SMB PLUGS & ANGLE PLUGS

Cable RG-/U	Connector Description	Cable Attachment		c Dia		CAI	Plt.	Ins.	Notes	Amphenol Number	Fig.
		Outer	Inner	A	B						
179	Plug	Crimp	Solder	.128(3.3)	.152(3.86)	C60	PCF	D32	Nickel Plated Body	<b>903-536P-71S</b>	1
	Angle Plug	Crimp	Solder	.128(3.3)	.152(3.86)	C61	PCF	D32	Nickel Plated Body	<b>903-535P-71A</b>	2
735A Type	Plug	Crimp	Solder	.167(4.24)	.214(5.43)	C60	PCF	D32	Nickel Plated Body	<b>903-516P-71S</b>	1
	Angle Plug	Crimp	Solder	.167(4.24)	.214(5.43)	C61	PCF	D32	Nickel Plated Body	<b>903-517P-71A</b>	2

# SMB 75 ohm High Density Coaxial Connectors

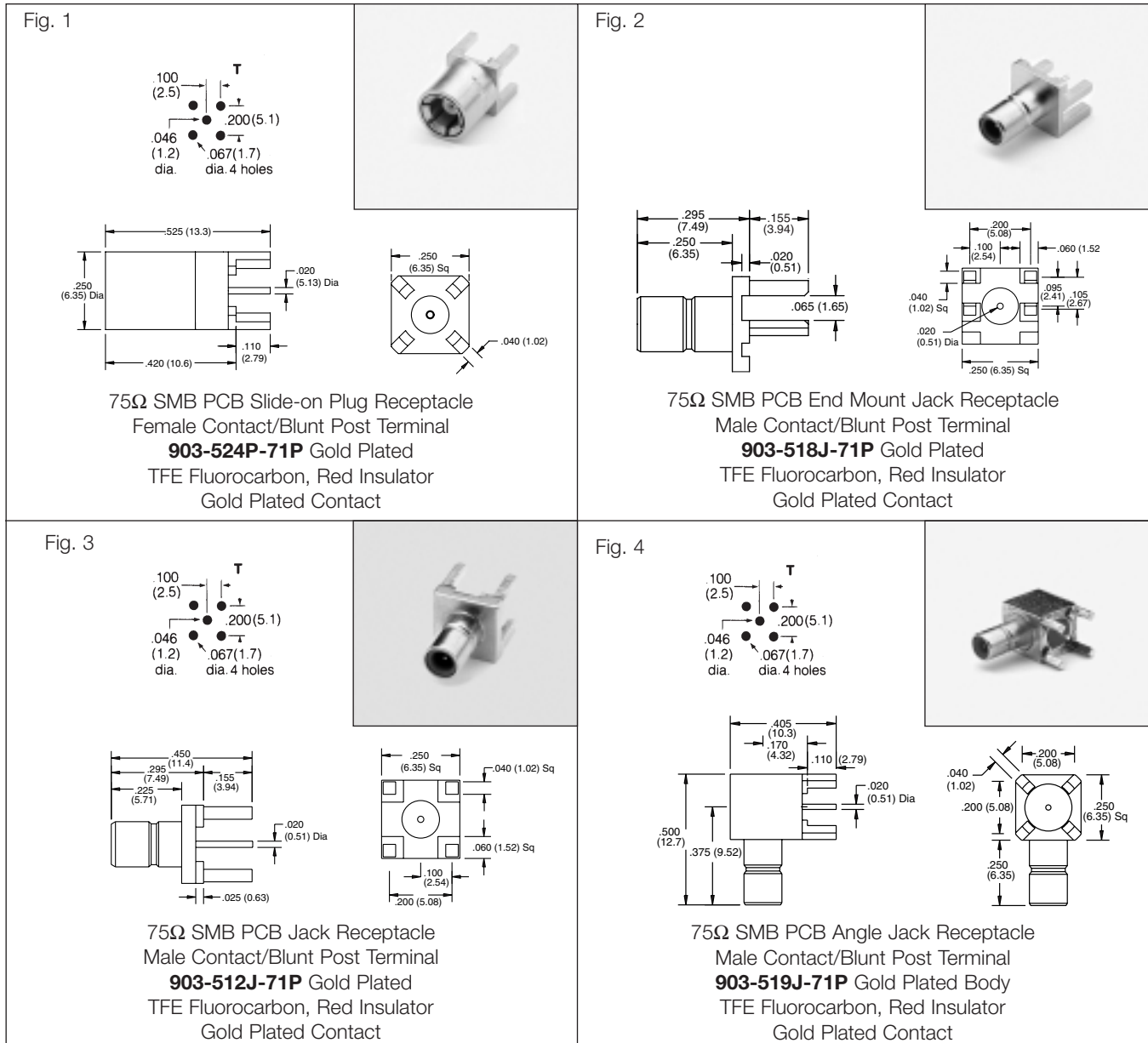

## 75 ohm SMB PRINTED CIRCUIT BOARD RECEPTACLES

Connector Description	Terminal Type	MTG Hole	Pt.	Ins	Construction Notes	Amphenol Number	Fig.
PCB Slide-on Plug Receptacle/Four Legs	Blunt Post	T	PCF	D32	Gold Plt. Body/Red TFE Ins.	<b>903-524P-71P</b>	1
PCB End mount Jack Receptacle/Four Legs	Blunt Post	—	PCF	D32	Gold Plt. Body/Red TFE Ins.	<b>903-518J-71P</b>	2
PCB Jack Receptacle/Four Legs	Blunt Post	T	PCF	D32	Gold Plt. Body/Red TFE Ins.	<b>903-512J-71P</b>	3
PCB Angle Jack Receptacle/Four Legs	Blunt Post	T	PCF	D32	Gold Plt. Body/Red TFE Ins.	<b>903-519J-71P</b>	4

**Notes**

Lined area for notes, consisting of numerous horizontal dotted lines.

**Description**

The SMC name derives from SubMiniature C (the third subminiature design). The SMC design was developed in the 1960's. SMC has threaded coupling with 10-32 threads.

Available in 50 & 75 ohm impedance.

Utilizes die cast components on non-critical areas to provide a low cost solution.

**Features/Benefits**

- Broadband performance with low reflection DC to 10 GHz provides low cost connector combined with high quality.
- Conforms to the interface dimensions of MIL-STD-348 provides intermatability with other connector suppliers. Offers customer second source.
- 10-32 screw-on (threaded) coupling mechanism allows performance to 10 GHz with low reflection.
- Right Angle connectors available in one piece construction ensures better performance combined with low cost.

**Application**

- Antennas
- Automotive (GPS)
- Base Stations
- Cable Assemblies
- Components
- Instrumentation
- PC/LAN
- Process Controls
- Radio Boards
- Surge Protection
- Telecom
- Test and Measurement
- Video Systems

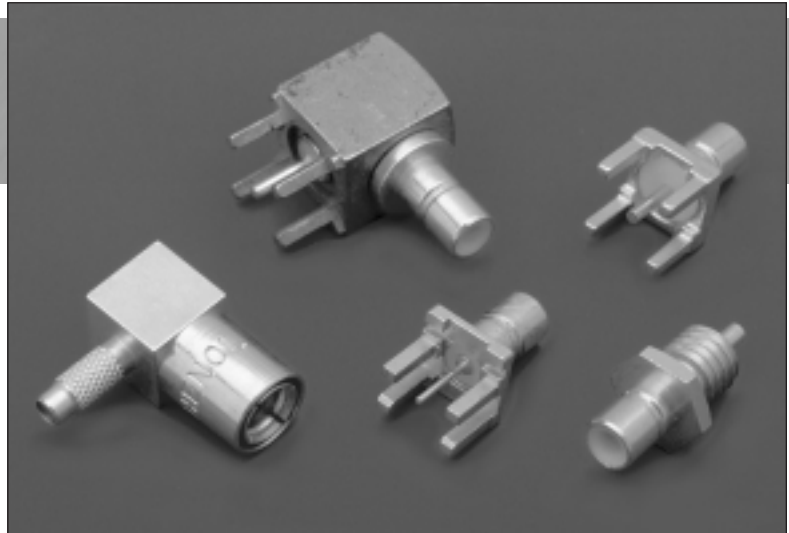

**SMC Connectors**

Specifications	52
Plugs, Jacks, Receptacles	53
Straight and Right Angle PCB	54

### ELECTRICAL

Impedance	50 ohms
Frequency range	0-4 GHz with low reflection; usable to 10.0 GHz
Voltage rating	Sea level: 335 volts 70,000 ft: 85 volts
Dielectric Withstanding voltage (max.)	750 VRMS RG-196 1000 VRMS for RG-188 type
VSWR straight connectors rt. angle connectors	RG-196/U series 1.30 + .04 f (GHz) 1.45 + .06 f (GHz)
straight connectors rt. angle connectors	RG-188/U series 1.25 + .04 f (GHz) 1.35 + .06 f (GHz)
Contact resistance Center: initial after environ. Outer: initial after environ. Braid to body: initial after environ.	6.0 milliohms 8.0 milliohms 1.0 milliohms 1.5 milliohms 1.0 milliohms N/A
Insulation resistance	1000 megohms min.
RF leakage	-55 dB min. @ 2-3 GHz
Insertion Loss straight connectors rt. angle connectors	0.30 dB @ 1.5 GHz 0.60 dB @ 1.5 GHz

### MECHANICAL

Mating	50 Ohm screw-on coupling per MIL-STD-348
Mating torque	Recommended 2-3" lbs. maximum 6.2" lbs. 80-110 N.cm
Connector affixment to cable	Braid and Jacket: hex. crimp
Cable affixment to center contact	Solder
Contact captivation	All types, except as noted
Cable retention	Equal to breaking strength of cable employed
Connector durability	500 mating and unmating cycles min.

### MATERIAL

Bodies	Brass per QQB-626 or zinc per ASTM B86-71, as specified, nickel or gold plated as listed
Center contacts	Female: beryllium copper, gold plated Male: brass or beryllium copper, gold plated
Outer contact	Nickel or gold plated as listed
Crimp ferrules	Annealed copper alloys
Insulators	TFE

### ENVIRONMENTAL

Temperature range	-65°C to + 165°C
Thermal shock	MIL-Std. 202 method 107 condition C
Vibration	MIL-Std. 202 method 204 condition D
Shock	MIL-Std. 202 method 213 condition C
Corrosion	MIL-Std. 202 method 101 condition B

### PLUG

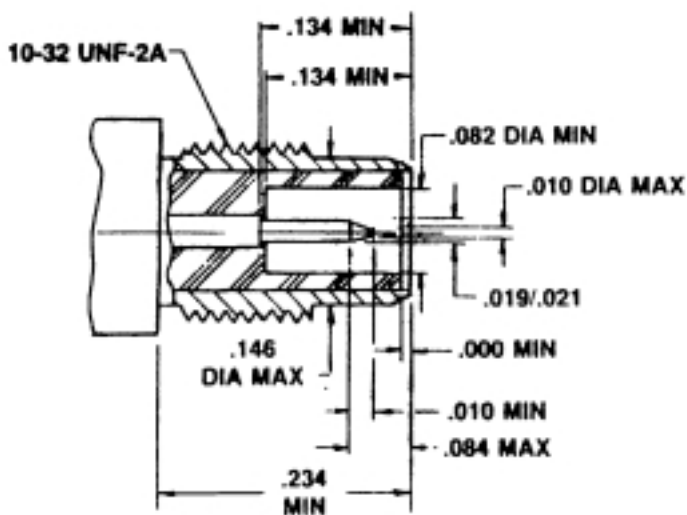

### JACK

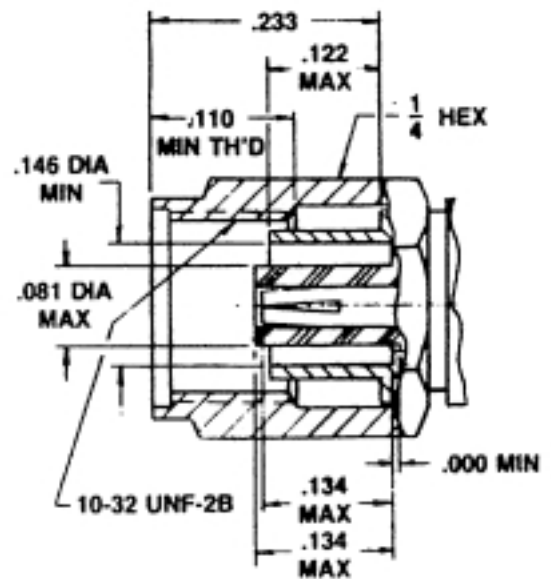

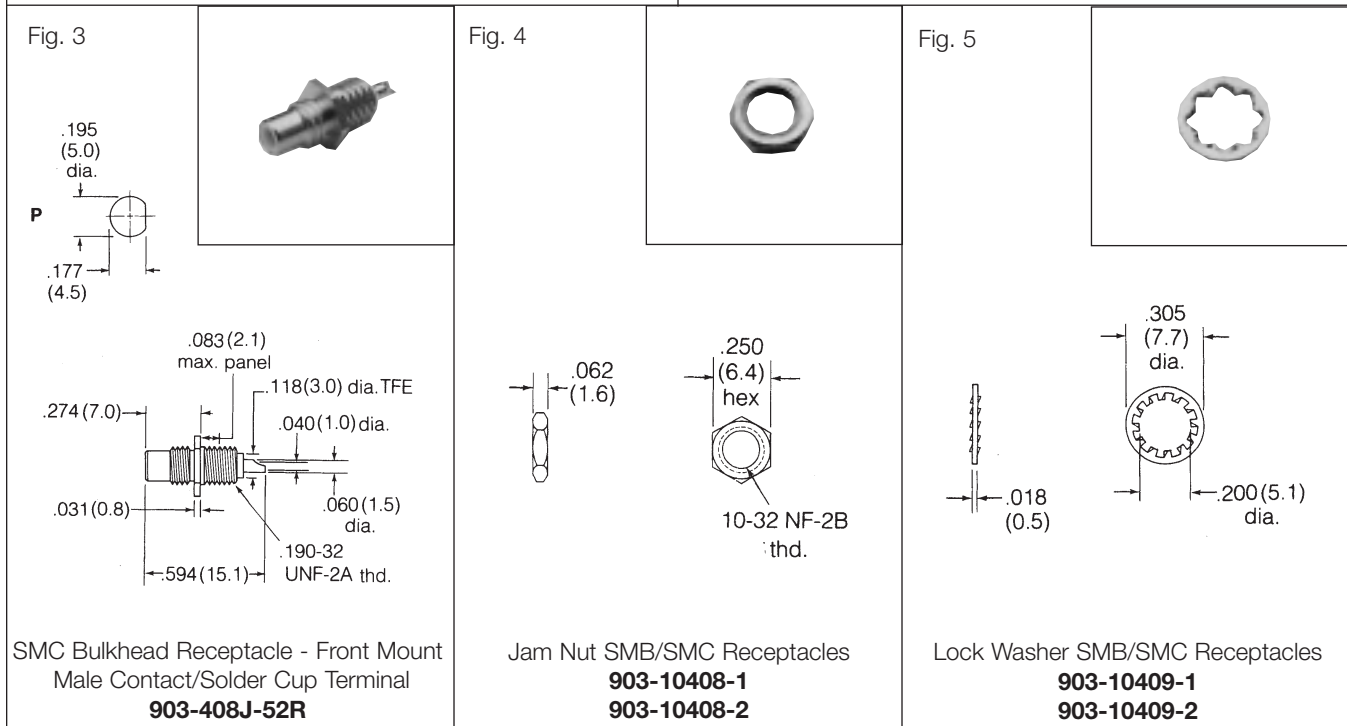
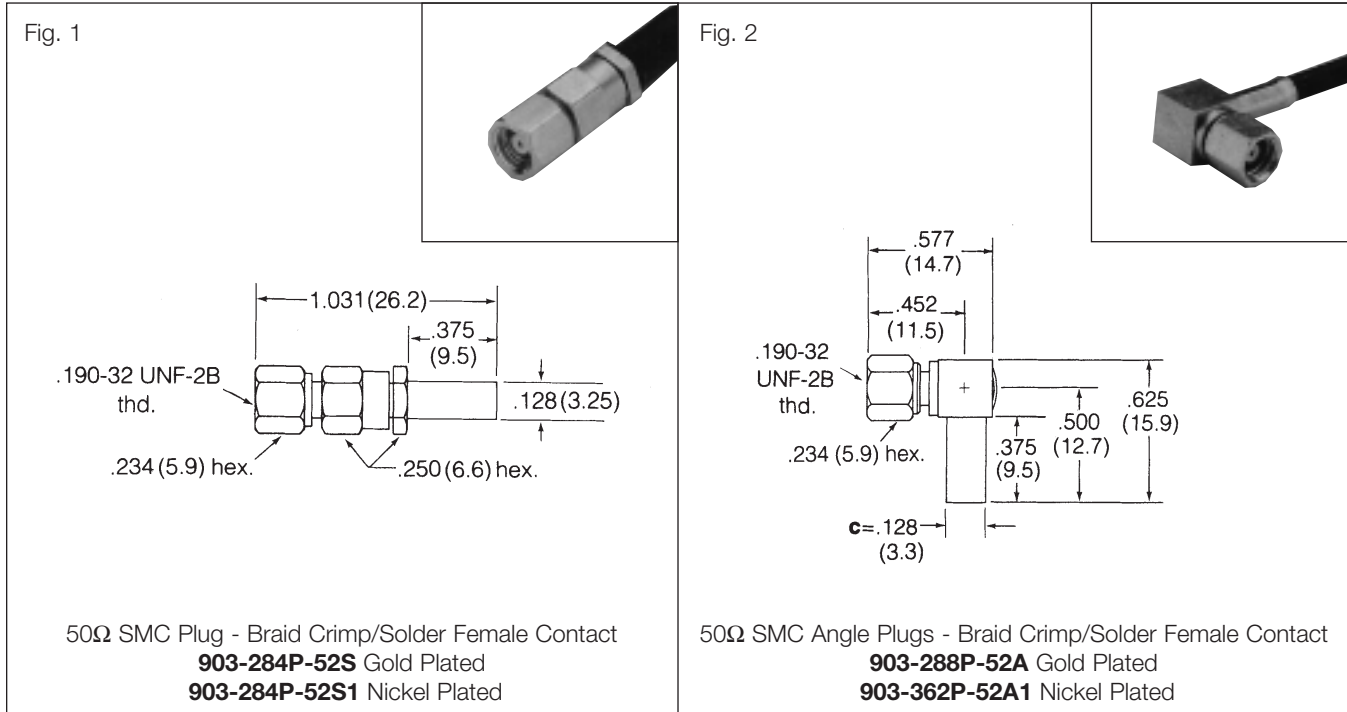

**SMC PLUGS, ANGLE PLUGS, BULKHEAD RECEPTACLES & ACCESSORIES**

Cable RG-/U	Connector Description	Cable Attachment		c Dia. In. (mm)	MTG Hole	CAI	Plt.	Ins.	Notes	Amphenol Number	Fig.
		Outer	Inner								
RG-174, 179, 187 188, 316	Plug	Crimp	Solder	.128 (3.3)	—	C25	P19	D1	Gold plated body	<b>903-284P-52S</b>	1
	Angle Plug	Crimp	Solder	.128 (3.3)	—	C26	P19	D1	Nickel plated body	<b>903-284P-52S1</b>	2
Dbl. Br. 316	Angle Plug	Crimp	Solder	.100 (2.5)	—	C26	P32	D1	Nickel plated body	<b>903-362P-52A1</b>	2
—	Bulkhead Jack Rec. Front solder/mount cup term.	—	—	—	P	—	P19	D1	Gold plated / captive contact	<b>903-408J-52R</b>	3
—	Jam nut for SMB/SMC Receptacles	—	—	—	—	—	P42	—	Gold plated	<b>903-10408-1</b>	4
—	Lockwasher for SMB/SMC receptacles	—	—	—	—	—	P4	—	Nickel plated	<b>903-10408-2</b>	
—	Lockwasher for SMB/SMC receptacles	—	—	—	—	—	P42	—	Gold plated	<b>903-10409-1</b>	5
—	Lockwasher for SMB/SMC receptacles	—	—	—	—	—	P4	—	Nickel plated	<b>903-10409-2</b>	

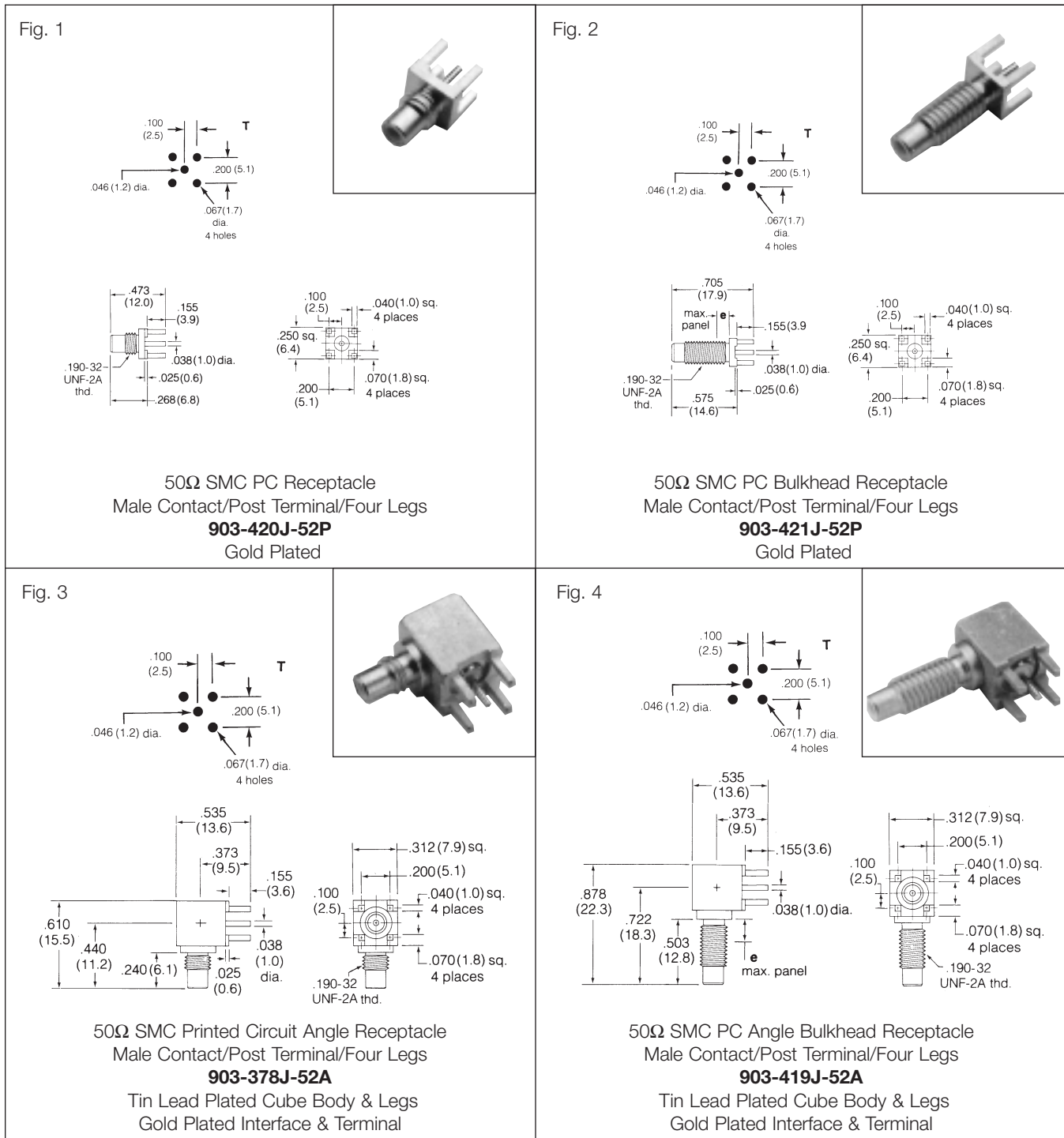

**75 ohm SMB PRINTED CIRCUIT BOARD RECEPTACLES**

Connector Description	Terminal Type	MTG Hole	Plt.	Ins	Construction Notes	Dim. e	Amphenol Number	Fig.
Printed Circuit Straight Jack Receptacle	Blunt Post	T	P19	D1	—	—	<b>903-420J-52P</b>	1
Printed Circuit Straight Bulkhead Jack Receptacle	Blunt Post	T	P19	D1	—	.125 (3.2)	<b>903-421J-52P</b>	2
Printed Circuit Right Angle Jack Receptacle	Blunt Post	T	P27	D1	Leak Tight	—	<b>903-378J-52A</b>	3
Printed Circuit Right Angle Bulkhead Jack Receptacle	Blunt Post	T	P27	D1	Leak Tight	.125 (3.2)	<b>903-419J-52</b>	4





**Description**

SMA is an acronym for SubMiniature version A and was developed in the 1960's. It uses a threaded interface.

50 ohm SMA connectors are semi-precision, sub-miniature units which provide excellent electrical performance from DC to 18 Ghz. These high performance connectors are compact in size and mechanically have outstanding durability.

Built in accordance with MIL-C-39012 and CECC 22110/111. They can be mated with all connectors which meet these spec mating diameters regardless of manufacturer.

**Features/Benefits**

- Broadband performance DC to 18 GHz with low reflection stainless steel construction with 1/4-36 threaded coupling offers high performance in a compact design.
- Low cost Commercial Grade (Brass SMA) available in nickel or gold plating, flexible provides approximately 30% reduction in cost with 250 mating cycles.
- Various flexible cable groups including: .086 and .141 semi-rigid allows customer flexibility in their design with a durable connector.

**Application**

- Base Stations
- Cable Assemblies
- Components
- Instrumentation
- Mil/Aero
- PC/LAN
- Process Controls
- Telecom

**Stainless Steel**

Specifications	56-57
Plugs	58-61
Jacks	62-63
Receptacles	64-73
In-Series Adapters	74-75

**Brass**

Specifications	76
Plugs, Jacks	77-78
Receptacles	79-82

**Phase Adjustable Connectors**

Specifications	83
Plugs and Adapters	84

## ELECTRICAL

Impedance	50 ohms
Frequency range	.141" & .085" O.D. copper jacket semi-rigid cable. 0-18GHz. Flexible cables: 0-12.4 GHz.
Voltage rating	RG-55, 58, 141, 142, 223, 303: 500 volts peak RG-122, 174, 188, 316, 375 volts peak
Dielectric withstanding voltage	.141" & RG-58 group: 1,000 VRMS. .085" & RG-316 group: 750 VRMS.
VSWR (straight connectors)	.141" O.D. copper jacket cable: 1.05 + .005 f (GHz) RG-55 group: 1.15 + .011 f (GHz) RG-122 group: 1.15 + .02 f (GHz) RG-178 group: 1.20 + .025 f (GHz)
(angle connectors)	.141" O.D. copper jacket cable: 1.10 + .01 f (GHz) RG-55 group: 1.15 + .02 f (GHz) RG-122 group: 1.15 + .03 f (GHz) RG-178 group: 1.20 + .03 f (GHz)
Contact resistance	Center: 2.0 milliohms Body: 2.0 milliohms Braid to body: 0.5 milliohms
Insulation resistance:	5000 megohms
RF leakage	-60 dB minimum
Insertion loss:	.03 √ f(GHz) dB max.

## ENVIRONMENTAL

Temperature range	-65°C to + 165°C
Thermal shock	MIL-Std. 202 method 107 (test cond. B) except high temp test @ + 200°C
Vibration	MIL-Std. 202 method 204 (test cond. D)
Shock	MIL-Std. 202 method 213 (test cond. I) No discontinuity permitted.
Corrosion	MIL-Std. 202 method 101 (test cond. B) 5% salt solution.
Moisture resistance	MIL-Std. 202 method 106, except step 7b (vibration) omitted, and high humidity measurements do not apply.
Weatherproofing	Crimp type: heat shrink tubing Solder type: silicone rubber gaskets
Altitude	MIL-Std. 202 method 105 (test cond. C), no corona at 70,000 ft. .141" & RG-55 group: 250 VRMS. .085" & RG-122 group: 190 VRMS.

## MECHANICAL

Mating	.250-36 threaded coupling
Mating torque	Minimum: 2 inch pounds 22 N.cm Recommended: 7 to 10 inch pounds 80-110 N.cm Maximum: 15 inch pounds 170 N.cm
Coupling nut retention	Axial force: 100 lbs. min., 300 N.cm Torque: 15 in. lbs. min. 76 N.cm Jacks: N/A
Connector affixment to cable	Crimp types, solder types
Cable affixment to center contact	Solder, except as noted
Contact captivation	All types, except as noted
Cable retention	Crimp type for RG-58, .141, 303=60 lbs min.; for RG-55, 142, 223 = 80 lbs min. 400 N.cm
Connector durability	500 mating and unmating cycles @ 12 cycles per min.

## MATERIAL

Bodies, coupling nuts, other metal parts (except as noted)	Non-magnetic stainless steel per QQ-S-764, Type 303.
Contacts	Beryllium copper per QQ-C-530, heat treated per MIL-H-7199.
Plating: Center contacts.	.00005" min. gold per MIL-G-45204, type 1, grade C. Gold over nickel unless otherwise requested.
Plating: Other metal parts	Gold plated or passivated to meet the finish and corrosion requirements of MIL-C-39012.
Insulators	TFE fluorocarbon per ASTM D1457.
Gaskets	Silicone rubber, per MIL-R-5847 and ZZ-R-765. class IIB, grade 65-75.
Lockwashers	Stainless steel, internal-tooth supplied with all bulkhead mounted connectors.
Crimp ferrules	Seamless copper tubing alloy # 122 (DHP), hard drawn to Rockwell 58-77 on 30-T scale per ASTM B75.

## MILITARY SPECIFICATIONS

MIL-C-39012 & MIL-C-83517 SMA specification sheets	As applicable
--	---------------

NOTE: These characteristics are typical and may not apply to all connectors.

Plug

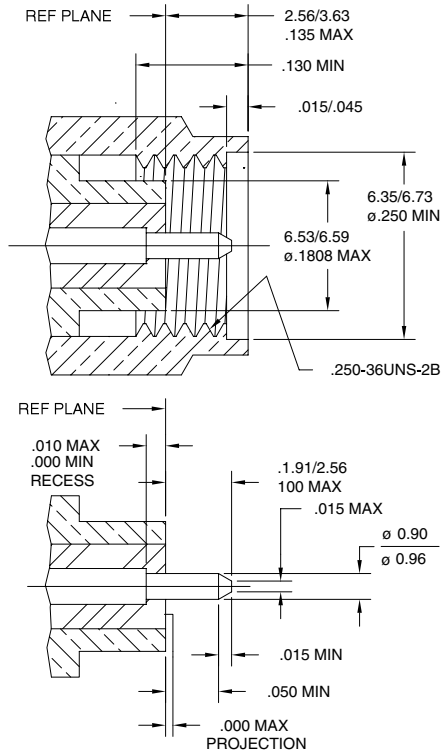

Jack

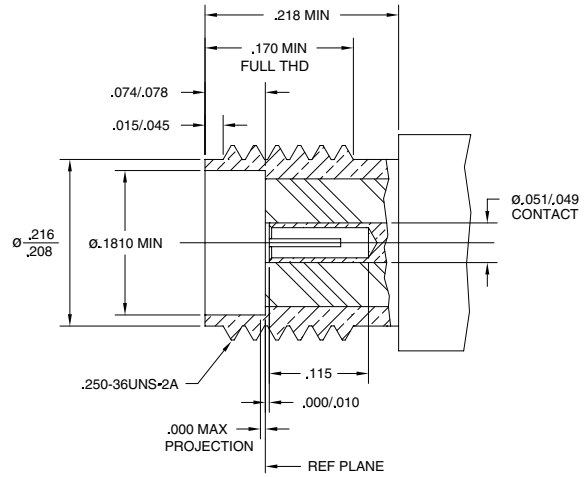

CECC = Cenelec Electronic Components Committee in Europe

<p>Fig. 1</p> <p>SMA Plugs - Solder to Body  <b>901-9201-2A</b>          for .085" (2.2mm) S/R, RG-405 (M17/133)          Gold Plated Nut [VSWR = 1.07 + .008(GHz) DC-18GHz]  <b>901-9201-2ASF</b>          for .085" (2.2mm) S/R, RG-405 (M17/130)          Gold Plated Passivated Nut  <b>901-9201-1A</b>          for .141" (3.6mm) S/R, RG-402 (M17/130)          Gold Plated Nut, without Contact &amp; Insulator  <b>901-9201-1ASF</b>          for .141" (3.6mm) S/R, RG-402 (M17/130)          Gold Plated Passivated Nut</p>	<p>Fig. 2</p> <p>VSWR = 1.35 max. DC-22GHz</p> <p>coupling nut for 901-9723 is .280(7.1) long.</p> <p>retaining "c" ring for 901-9723 only</p> <p>SMA Plugs - Solder to Body/          Pre-assembled Factory-Set Interface  <b>901-9723▲</b>          Passivated Nut, 100 piece Bulk Pack  <b>901-9723-10</b>          Passivated Nut, Single Pack          for .085" (2.2mm) S/R, RG-405 (M17/133)</p>
<p>Fig. 3</p> <p>VSWR = 1.35 max. DC-22GHz</p> <p><b>901-9808▲</b>          Gold Body, Passivated Nut  <b>901-9801-1</b>          Gold Body and Nut  <b>901-9801-2</b>          Gold Body, Passivated Nut          Preassembled Factory Set Interface          Single Pack          for .141" (3.6mm) S/R , RG-402 (M17/130)</p>	<p>Fig. 4</p> <p>SMA Plugs - Solder to Body/          Pre-assembled Factory-Set Interface  <b>901-9805-HP</b>          Passivated Nut, Single Pack          for .085" (2.2mm) S/R, RG-405 (M17/133)</p>

## SMA PLUGS FOR SEMI-RIGID CABLE – 50Ω impedance

Cable RG-/U	Cable Attachment		Dim. In. (mm)		CAI	Pit.	Ins.	Construction Notes	Amphenol Number	Fig.
	Outer	Inner	a	c						
<b>.085" (2.2mm) Semi-Rigid RG-405 (M17/133)</b>	Solder	Solder	.438(11.1)	.090(2.3)	C47	P10	D1	—	<a href="#">901-9201-2A</a>	1
	Solder	Plugable	.400(10.2)	.090(2.3)	C48	P10	D1	—	<a href="#">901-9201-2ASF</a>	1
	Solder	Plugable	.400(10.2)	.090(2.3)	C48	P10	D1	—	▲ <a href="#">901-9723</a>	2
	Solder	Plugable	.400(10.2)	.090(2.3)	C48	P11	D1	—	<a href="#">901-9723-10</a>	2
	Solder	Plugable	.531(13.5)	.090(2.3)	C48	P11	D1	—	<a href="#">901-9805-HP</a>	4
<b>.141" (3.6mm) Semi-Rigid RG-402 (M17/130)</b>	Solder	None	.445(11.3)	.145(3.7)	C50	P14	—	w/o Cont. & Ins.	<a href="#">901-9201-1A</a>	1
	Solder	None	.445(11.3)	.145(3.7)	C50	P14	—	Gold plated body☞	▲ <a href="#">901-9201-1ASF</a>	1
	Solder	Plugable	.438(11.1)	.145(3.7)	C48	P10	D1	Gold plated body☞	<a href="#">901-9808</a>	3
	Solder	Plugable	.438(11.1)	.145(3.7)	C48	P10	D1	Gold plated body☞	<a href="#">901-9801-1</a>	3
	Solder	Plugable	.438(11.1)	.145(3.7)	C48	P10	D1	Gold plated body☞	<a href="#">901-9801-2</a>	3

▲ distributor stocked

☞ passivated nut

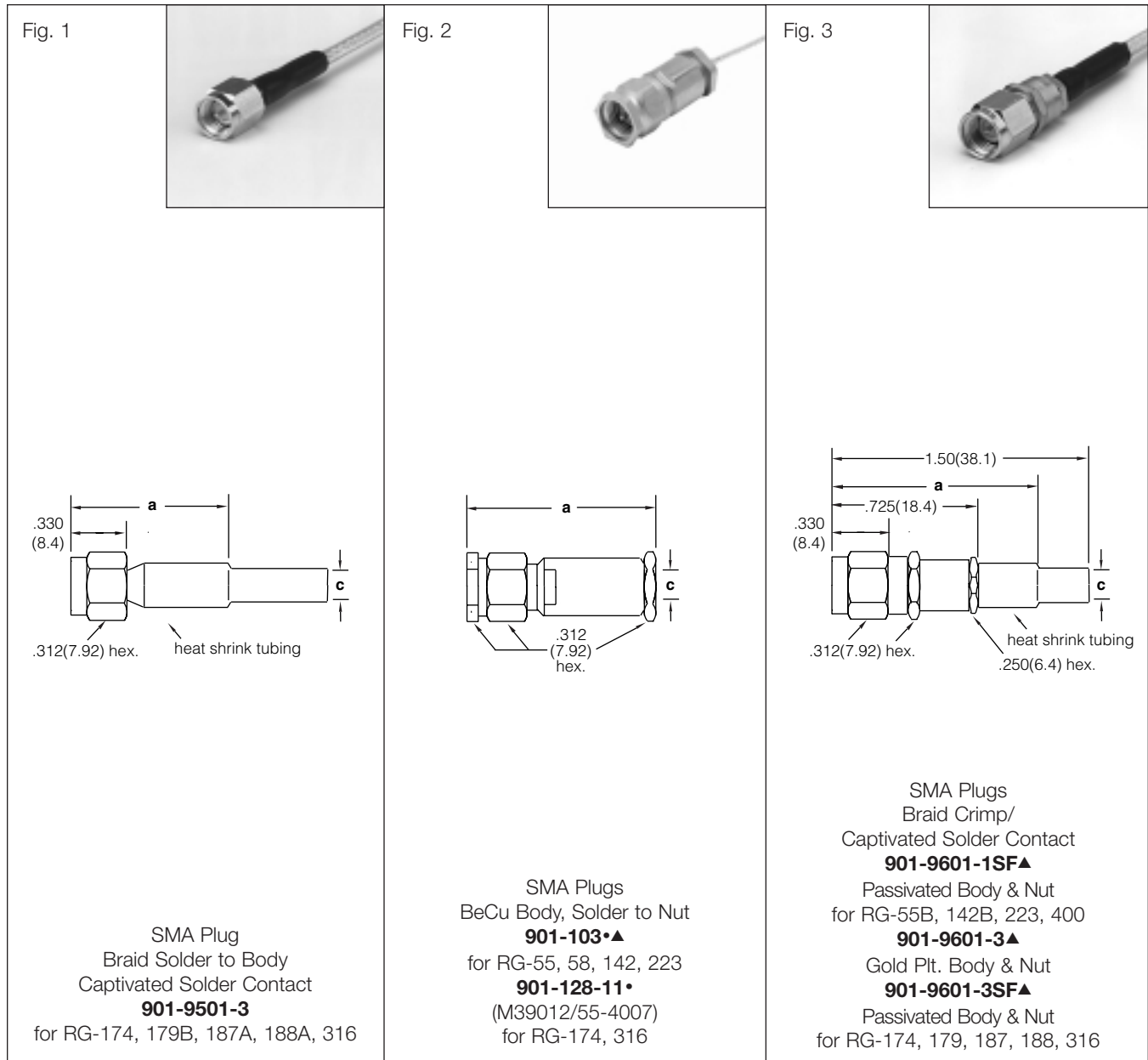

## SMA PLUGS FOR FLEXIBLE CABLE – 50Ω impedance

Cable RG-/U	Cable Attachment		Dim. In. (mm)		CAI	Plt.	Ins.	Construction Notes	Mil. No. 39012/	Amphenol Number	Fig.
	Outer	Inner	a	c							
<b>55, 58, 141, 142, 223</b>	Clamp	Solder	.969(24.6)	.219(5.6)	C43	P9	D1	BeCu Body	—	▲ <b>901-103</b>	2
<b>55B, 142B, 223, 400</b>	Crimp	Solder	1.10(28.0)	.220(5.6)	C56	P12	D1	Captivated Contact	—	▲ <b>901-9601-1SF</b>	3
<b>174, 179, 187, 188, 316</b>	Crimp	Solder	1.10(28.0)	.128(3.3)	C56	P9	D1	Captivated Contact	—	▲ <b>901-9601-3</b>	3
	Crimp	Solder	1.10(28.0)	.128(3.3)	C56	P12	D1	Captivated Contact	—	▲ <b>901-9601-3SF</b>	3
<b>174, 179B, 187A, 188A, 316</b>	Solder	Solder	.690(17.5)	.128(3.3)	C46	P11	D1	—	—	<b>901-9501-3</b>	1
<b>174, 316</b>	Clamp	Solder	.984(25.0)	.114(2.9)	C44	P9	D1	BeCu Body	55-4007	• <b>901-128-11</b>	2

• safety wire holes ▲ distributor stocked

**Fig. 1**

SMA Plugs  
Braid Crimp/  
Non-Captivated Solder Contact

**901-9511-1▲**  
Gold Plt. Body & Nut  
**901-9511-1SF▲**  
Passivated Body & Nut  
for RG-55B, 142B, 223, 400

**901-9511-3▲**  
Gold Plt. Body & Nut  
**901-9511-3SF▲**  
Passivated Body & Nut  
for RG-174, 179, 187, 188, 316

**901-9511-12SF▲**  
Passivated Body & Nut  
for Double Braid RG-316

**901-9511-2**  
Gold Plt. Body & Nut  
**901-9511-2SF**  
Passivated Body & Nut  
for RG-58

**901-10011**  
Passivated Body & Nut  
for LMR 240

**901-10012**  
Passivated Body & Nut  
for LMR 200

**Fig. 2**

SMA Plugs  
Braid Crimp/  
Crimp Center Contact  
with Passivated Body & Nut

**901-9511-1SFC**  
for RG-55B, 142B, 223, 400

**901-101-15†**  
BeCu Body  
(M39012/55-4502)  
for RG-142B, 400





**901-9511-3SFC**  
for RG-174, 179, 187, 188, 316

**901-9511-12SFC**  
for Double Braid RG-316

## SMA PLUGS FOR FLEXIBLE CABLE – 50Ω impedance

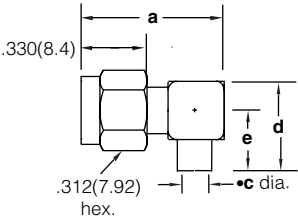
Cable RG-/U	Cable Attachment		Dim. In. (mm)		CAI	Plt.	Ins.	Construction Notes	Mil. No. 39012/	Amphenol Number	Fig.
	Outer	Inner	a	c							
55B, 142B, 223, 400	Crimp	Solder	.812(20.6)	.220(5.6)	C53	P10	D1	Non-Captive Contact	—	▲ 901-9511-1	1
55B, 142B, 223, 400	Crimp	Solder	.812(20.6)	.220(5.6)	C53	P13	D1	Non-Captive Contact	—	▲ 901-9511-1SF	1
58	Crimp	Solder	.812(20.6)	.206(5.2)	C53	P11	D1	—	—	901-9511-2	1
58	Crimp	Solder	.812(20.6)	.206(5.2)	C53	P10	D1	—	—	901-9511-2SF	1
174, 187, 188, 316	Crimp	Solder	.812(20.6)	.128(3.3)	C55	P10	D1	Non-Captive Contact	—	▲ 901-9511-3	1
174, 187, 188, 316	Crimp	Solder	.812(20.6)	.128(3.3)	C55	P13	D1	Non-Captive Contact	—	▲ 901-9511-3SF	1
Dbl. Braid RG-188, 316	Crimp	Solder	.812(20.6)	.142(3.6)	C55	P13	D1	Non-Captive Contact	—	▲ 901-9511-12SF	1
LMR 240	Crimp	Solder	1.03(26.2)	.261(6.6)	C53	P13	D1	Non-Captive Contact	—	901-10011	1
LMR 200	Crimp	Solder	.810(20.6)	.206(5.2)	C53	P13	D1	Non-Captive Contact	—	901-10012	1
55B, 142B, 223, 400	Crimp	Crimp	.812(20.6)	.220(5.6)	C55	P13	D1	—	—	901-9511-1SFC	2
142B, 400	Crimp	Crimp	1.03(26.2)	.220(5.6)	C55	P9	D1	BeCu Body	55-4502	•† 901-101-15	2
174, 179, 187, 188, 316	Crimp	Crimp	.812(20.6)	.128(3.5)	C55	P13	D1	—	—	901-9511-3SFC	2
Dbl. Braid RG-188, 316	Crimp	Crimp	.812(20.6)	.142(3.6)	C55	P13	D1	—	—	901-9511-12SFC	2

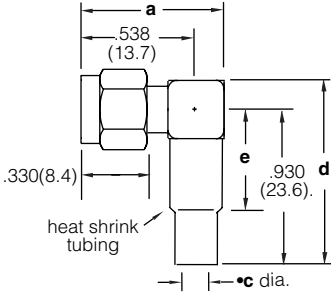

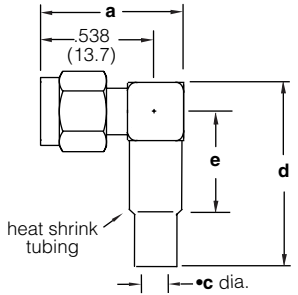

• safety wire holes † for crimping center contact, use Tool Handle M22520/1-01 and Crimp Die M22520/1-15 ▲ distributor stocked

<p>Fig. 1</p>   <p>SMA Angle Plugs Solder to Body <b>901-9221-2A</b> Gold Plated Nut <b>901-9221-2ASF</b> Passivated Nut for 085" (2.2mm) S/R RG-405 (M17/133) <b>901-9221-1A</b> Gold Plated Nut <b>901-9221-1ASF</b> Passivated Nut for 141" (3.6mm) S/R RG-402 (M17/130)</p>	<p>Fig. 2</p>   <p>SMA Angle Plugs Solder to Nut <b>901-9531-1▲</b> Gold Plt. Body &amp; Nut for RG-55, 142, 223, 400 <b>901-9531-2</b> Gold Plt. Body &amp; Nut <b>901-9531-2SF</b> Passivated Body for RG-58, 141 <b>901-9531-1SF▲</b> Passivated Body for SF142B <b>901-9531-3▲</b> Gold Plt. Body &amp; Nut <b>901-9531-3SF▲</b> Passivated Body for RG-174, 179, 187, 188, 316 <b>901-9531-12▲</b> Gold Plt. Body &amp; Nut <b>901-9531-12SF▲</b> Passivated Body for Double Braid RG-316 <b>901-10014</b> Passivated Body &amp; Nut for LMR240</p>	<p>Fig. 3</p>   <p>SMA Angle Plugs Braid Solder, Solder Contact <b>901-9521-3▲</b> for RG-174, 179, 187, 187A, 188, 188A, 316</p>
---	---	---

## SMA RIGHT ANGLE PLUGS FOR SEMI-RIGID & FLEXIBLE CABLE – 50Ω impedance

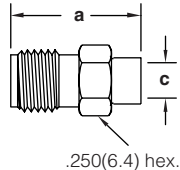
Cable RG-/U	Cable Attachment		Dim. In. (mm)				CAI	Plt.	Ins.	Notes	Mil. No. 39012/	Amphenol Number	Fig.
	Outer	Inner	a	c	d	e							
<b>.085" (2.2mm) Semi-Rigid RG-405 (M17/133)</b>	Solder	Solder	.680(17.3)	.090(2.3)	.430(10.9)	.305(7.7)	C49	P11	D1	—	—	<b>901-9221-2A</b>	1
	Solder	Solder	.680(17.3)	.090(2.3)	.430(10.9)	.305(7.7)	C49	P11	D1	—	—	<b>901-9221-2ASF</b>	1
<b>.141" (2.2mm) Semi-Rigid RG-402 (M17/130)</b>	Solder	Solder	.680(17.3)	.145(3.7)	.430(10.9)	.305(7.7)	C49	P11	D1	—	—	<b>901-9221-1A</b>	1
	Solder	Solder	.680(17.3)	.145(3.7)	.430(10.9)	.305(7.7)	C49	P11	D1	—	—	<b>901-9221-1ASF</b>	1
<b>55, 141, 142, 223, 400</b>	Crimp	Solder	.682(17.3)	.220(5.6)	1.05(26.7)	.550(14.0)	C53	P11	D1	Cap. Cont.	—	<b>▲ 901-9531-1</b>	2
<b>58, 141</b>	Solder	Solder	.682(17.3)	.206(5.2)	1.05(26.7)	.550(14.0)	C53	P11	D1	—	—	<b>901-9531-2</b>	2
	Crimp	Solder	.682(17.3)	.206(5.2)	1.05(26.7)	.550(14.0)	C53	P13	D1	—	—	<b>901-9531-2SF</b>	2
<b>174, 187, 188, 316</b>	Crimp	Solder	.682(17.3)	.128(3.3)	1.05(26.7)	.550(14.0)	C57	P11	D1	Cap. Cont.	—	<b>▲ 901-9531-3</b>	2
	Crimp	Solder	.682(17.3)	.128(3.3)	1.05(26.7)	.550(14.0)	C57	P13	D1	Cap. Cont.	—	<b>▲ 901-9531-3SF</b>	2
<b>174, 179, 187, 187A, 188, 188A, 316</b>	Solder	Solder	.675(17.1)	.128(3.3)	1.12(28.4)	.440(11.2)	C46	P11	D1	—	—	<b>▲ 901-9521-3</b>	3
<b>SF 142B, Times AA-2423</b>	Crimp	Solder	.675(17.1)	.219(5.6)	1.06(26.9)	.475(12.1)	C53	P13	D1	—	—	<b>▲ 901-9531-1SF</b>	2
<b>Double Braid RG-316</b>	Crimp	Solder	.682(17.3)	.142(3.6)	1.05(26.7)	.550(14.0)	C57	P11	D1	Cap. Cont.	—	<b>▲ 901-9531-12</b>	2
	Crimp	Solder	.682(17.3)	.142(3.6)	1.05(26.7)	.550(14.0)	C57	P13	D1	Cap. Cont.	—	<b>▲ 901-9531-12SF</b>	2
<b>LMR 240</b>	Crimp	Solder	.682(17.3)	.261(1.7)	1.00(25.4)	.685(17.4)	C57	P13	D1	—	—	<b>901-10014</b>	2

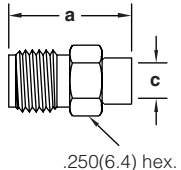
▲ distributor stocked

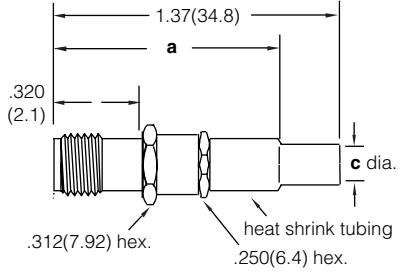
<p>Fig. 1</p>   <p style="text-align: center;">SMA Jacks Solder to Body Solder Center Contact <b>901-9202-1A</b> for .141" (3.6mm) S/R RG-402 (M17/130) <b>901-9202-2A</b> for .085" (2.2mm) S/R RG-405 (M17/133)</p>	<p>Fig. 2</p>   <p style="text-align: center;">SMA Jack Solder to Body Pre-assembled Center Contact <b>901-9704</b> Gold Plated for .141" (3.6mm) S/R RG-402 (M17/130)</p>	<p>Fig. 3</p>   <p style="text-align: center;">SMA Jacks Braid Crimp Solder Captive Contact <b>901-9602-1</b> Gold Plated, <b>901-9602-1SF</b> Passivated for RG-55B, 142B, 223, 400 <b>901-9602-3</b> Gold Plated, <b>901-9602-3SF</b> Passivated for RG-174, 179, 187, 188, 316 <b>901-9602-12SF</b> Passivated for Double Braid RG-316</p>
---	---	---

## SMA JACKS FOR SEMI-RIGID & FLEXIBLE CABLES – 50Ω Impedance

Cable RG-/U	Cable Attachment		Dimensions In. (mm)		CAI	Plt.	Ins.	Notes	Amphenol Number	Fig.
	Outer	Inner	a	c						
<b>.085" (3.6mm) Semi -Rigid (RG-405) (M17/133)</b>	Solder to Body	Solder	.500(12.7)	.088(2.2)	C47	P9	D1	—	<a href="#">901-9202-2A</a>	1
<b>.141" (3.6mm) Semi -Rigid RG-402 (M17/130)</b>	Solder to Body	Solder	.500(12.7)	.144(3.7)	C47	P10	D1	—	<a href="#">901-9202-1A</a>	1
	Solder to Body	Solder	.500(12.7)	.144(3.7)	C59	P11	D1	Pre-assembled Cont.	<a href="#">901-9704</a>	2
<b>55, 142, 223, 400</b>	Crimp	Solder	.965(24.5)	.220(5.6)	C56	P9	D1	Captive Contact	<a href="#">901-9602-1</a>	3
	Crimp	Solder	.965(24.5)	.220(5.6)	C56	P12	D1	Captive Contact	<a href="#">901-9602-1SF</a>	3
<b>174, 179, 187, 188, 316</b>	Crimp	Solder	.965(24.5)	.128(3.3)	C56	P9	D1	Captive Contact	<a href="#">901-9602-3</a>	3
	Crimp	Solder	.965(24.5)	.128(3.3)	C56	P12	D1	Captive Contact	<a href="#">901-9602-3SF</a>	3
<b>Double Braid RG-316</b>	Crimp	Solder	.965(24.5)	.142(3.6)	C56	P12	D1	Captive Contact	<a href="#">901-9602-12SF</a>	3



<p>Fig. 1</p> <p>SMA Bulkhead Jacks Solder to Body Solder Center Contact Gold Plated <b>901-9210-1</b> for .141" (3.6mm) S/R RG-402 (M17/130) <b>901-9210-2</b> for .085" (2.2mm) S/R RG-405 (M17/133)</p>	<p>Fig. 2</p> <p>SMA Bulkhead Jacks Braid Crimp Captive Contact Solder Center Contact <b>901-9610-1SF▲</b> Passivated for RG-55B, 142B, 223, 400 <b>901-9610-3▲</b> Gold Plated <b>901-9610-3SF▲</b> Passivated for RG174, 179, 187, 188, 316 <b>901-9610-12SF</b> Passivated for Double Braid RG-316 <b>901-10015</b> Passivated for LMR 240</p>	<p>Fig. 3</p> <p>SMA Bulkhead Jacks Braid Crimp Solder Center Contact <b>901-10021-1SF▲</b> Passivated for RG-55B, 142B, 223, 400 <b>901-10021-3SF▲</b> Passivated for RG174, 179, 187, 188, 316 <b>901-10021-12SF</b> Passivated for Double Braid RG-316</p>
--	---	---

## SMA BULKHEAD JACKS FOR SEMI-RIGID & FLEXIBLE CABLES – 50Ω Impedance

Cable RG-/U	Cable Attachment		Dimensions In. (mm)		CAI	Plt.	Ins.	Notes	Amphenol Number	Fig.
	Outer	Inner	a	c						
<b>.085" (2.2mm) Semi-Rigid RG-405 (M17/133)</b>	Solder to Body	Solder	.750(19.1)	.090(2.3)	C47	P9	D1	—	<b>901-9210-2</b>	1
<b>.141" (3.6mm) Semi-Rigid RG-402 (M17/130)</b>	Solder to Body	Solder	.750(19.1)	1.44(3.7)	C47	P10	D1	—	<b>901-9210-1</b>	1
<b>55, 142, 223, 400</b>	Crimp	Solder	1.50(38.1)	.220(5.6)	C56	P13	D1	Capt. Contact	<b>▲ 901-9610-1SF</b>	2
	Crimp	Solder	1.50(38.1)	.220(5.6)	C56	P13	D1	Non Capt. Contact	<b>▲ 901-10021-1SF</b>	3
<b>174, 179, 187, 188, 316</b>	Crimp	Solder	1.50(38.1)	.128(3.3)	C56	P11	D1	Capt. Contact	<b>▲ 901-9610-3</b>	2
	Crimp	Solder	1.50(38.1)	.128(3.3)	C56	P11	D1	Non Capt. Contact	<b>▲ 901-10021-3SF</b>	3
	Crimp	Solder	1.50(38.1)	.128(3.3)	C56	P13	D1	Capt. Contact	<b>▲ 901-9610-3SF</b>	2
<b>Double Braid 316</b>	Crimp	Solder	1.50(38.1)	.128(3.3)	C56	P13	D1	Non Capt. Contact	<b>▲ 901-10021-12SF</b>	3
	Crimp	Solder	1.50(38.1)	.142(3.6)	C56	P13	D1	Capt. Contact	<b>901-9610-12SF</b>	2
<b>LMR 240</b>	Crimp	Solder	1.08(27.4)	.261(6.6)	C56	P13	D1	Capt. Contact	<b>901-10015</b>	2

▲ distributor stocked

<p>Fig. 1</p>	<p>Fig. 2</p>	<p>Fig. 3</p>
<p>SMA Printed Circuit Receptacle Gold Plated Blunt Post Terminal Four Legs <b>901-144▲</b> .155(3.9) Legs &amp; Term. <b>901-144-2</b> .105(2.7) Solder Dipped Legs &amp; Term. <b>901-144-3</b> .155(3.9) Solder Dipped Legs &amp; Term. <b>901-144-4</b> .200(5.1) Legs &amp; Term with Stand-off Pads</p>	<p>SMA Printed Circuit Receptacle Gold Plated Blunt Post Terminal Four Legs .025 Stand-off Pads <b>901-143▲</b> .155(3.9) Legs &amp; Term. <b>901-143-3</b> .155(3.9) Solder Dipped Legs &amp; Term. <b>901-143-4</b> .105(2.7) Solder Dipped Legs &amp; Term.</p>	<p>SMA Printed Circuit Receptacle Edge Mount for .062" Printed Circuit Board <b>901-9850</b> for .062" Printed Circuit Board <b>901-10003</b> for .062" Printed Circuit Board <b>901-10019</b> for .032" Printed Circuit Board</p>

## SMA PRINTED CIRCUIT RECEPTACLES – female contacts

Description	Terminal Type	Pit.	Ins.	MTG Hole	Construction Notes	Dim. a	Amphenol Number	Fig.
Printed Circuit Board Panel Jack Receptacle	Blunt Post	P11	D1	T	Captive Contact	.155(3.9)	▲ <b>901-144</b>	1
					Solder Dipped Legs & Term	.105(2.7)	<b>901-144-2</b>	1
					Solder Dipped Legs & Term	.155(3.9)	<b>901-144-3</b>	1
					.025 Stand-off Pads	.200(5.1)	<b>901-144-4</b>	1
Printed Circuit Board Angle Jack Receptacle	Blunt Post	P11	D1	T	.025 Stand-off Pads	.155(3.9)	▲ <b>901-143</b>	2
					Solder Dipped Legs & Term	.155(3.9)	<b>901-143-3</b>	2
					Solder Dipped Legs & Term	.105(2.7)	<b>901-143-4</b>	2
Printed Circuit Board Edge Mt Jack Receptacle	Blunt Post	P10	D1	—	For .062" Thick PCB	.475 (12)	<b>901-9850</b>	3
	Blunt Post	P11	D1	—	For .062" Thick PCB	.375 (9.5)	<b>901-10003</b>	3
	Blunt Post	P11	D1	—	For .032" Thick PCB	.350(8.9)	<b>901-10019</b>	3



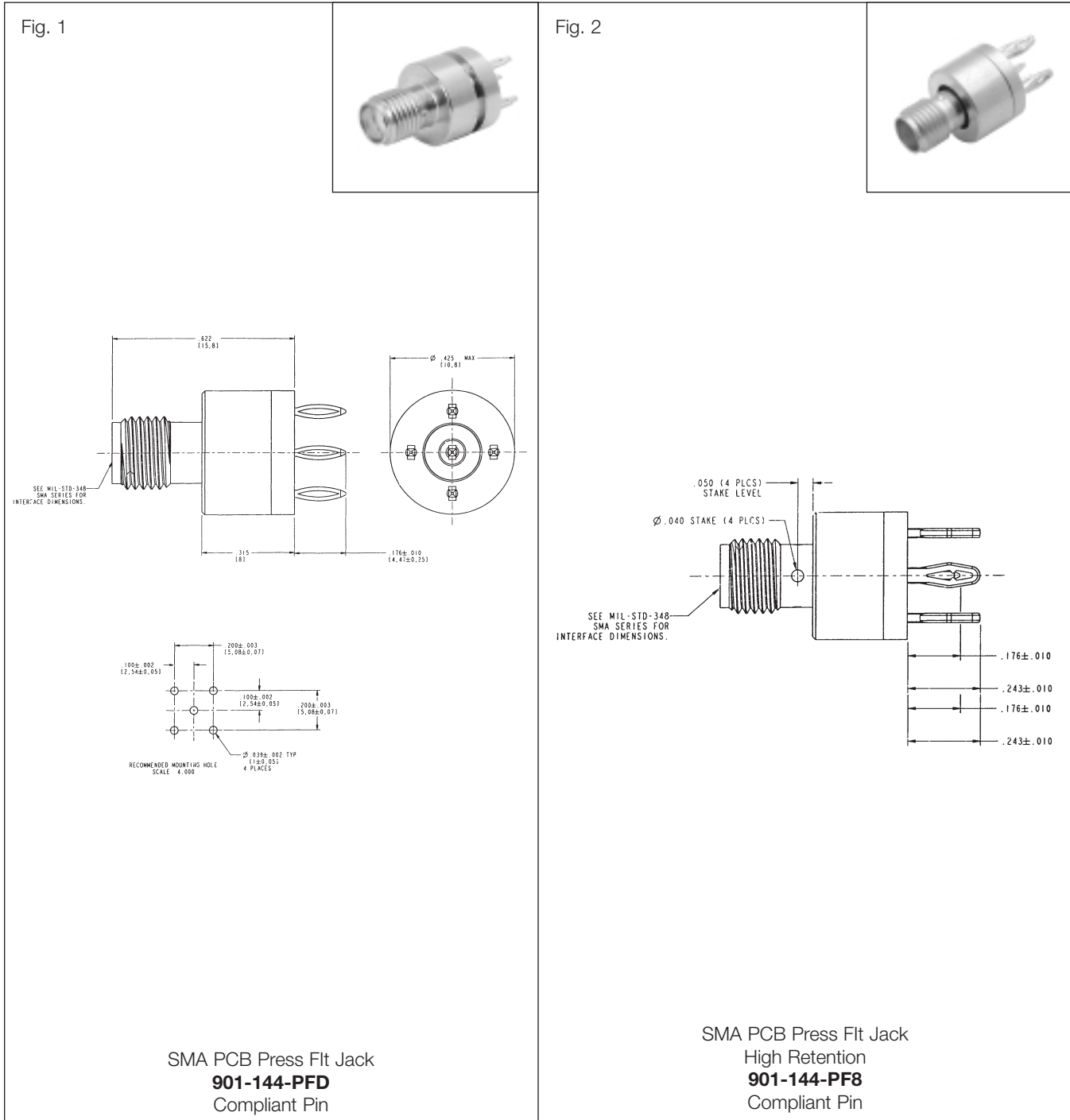

▲ distributor stocked

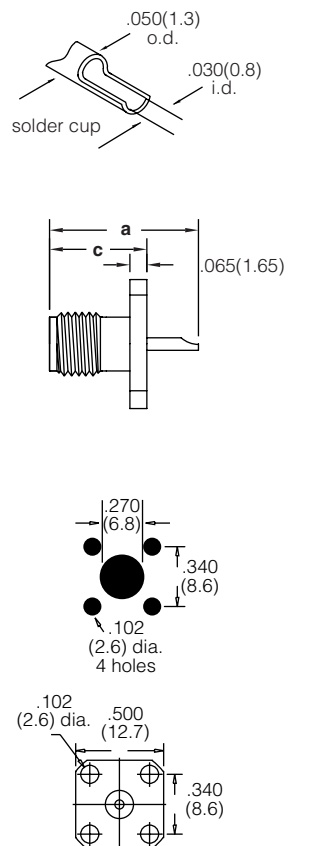

## SMA PCB PRESS FIT JACKS

Description	Terminal Type	Plt.	Ins.	Construction Notes	Amphenol Number	Fig.
SMA PCB Press-Fit Jack	Compliant Pin	P11	D1	Gold Plated Body, Legs Tin/Lead	<a href="#">901-144-PFD</a>	1
SMA PCB Press-Fit Jack	Compliant Pin	P11	D1	Gold Plated Body, Legs Tin/Lead	<a href="#">901-44-PF8</a>	2

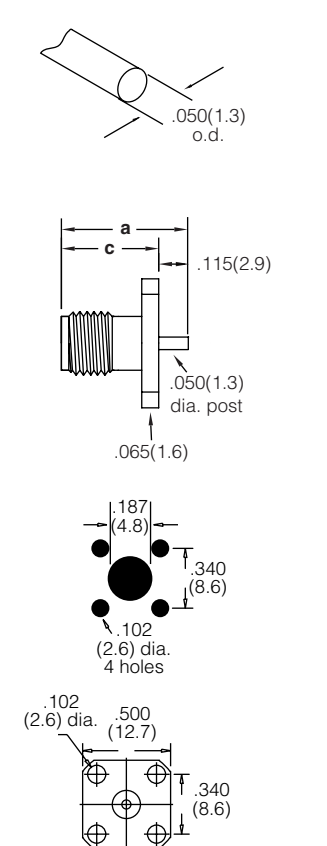
# Panel Jack Receptacles – 4-hole Flange

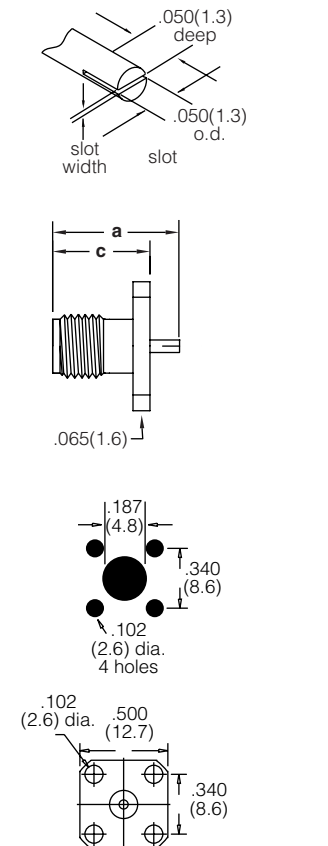
<p>Fig. 1</p>   <p>SMA Panel Jack Receptacle 4-Hole Square Flange Mount Solder Cup Terminal <b>901-9215</b> Gold Plated Body <b>901-9215-SF</b> Passivated Body</p>	<p>Fig. 2</p>   <p>SMA Panel Jack Receptacle 4-Hole Square Flange Mount Post Terminal Flush TFE Countersink Flange Holes <b>901-9758</b></p>	<p>Fig. 3</p>   <p>SMA Panel Jack Receptacle 4-Hole Square Flange Mount Slot Terminal <b>901-9204-4CC</b> Gold Plated Body <b>901-9204-4CCSF</b> Passivated Body <b>901-9204-3CCSF</b> Passivated Body</p>
--	---	---

## SMA PANEL JACK RECEPTACLES – 4-hole square flange mount

Terminal Type	Dimensions In. (mm)		Plt.	Ins.	Notes	Amphenol Number	Fig.
	a	c					
Solder Cup .200*(5.1mm) Long	.575(14.6)	.375(9.5)	P10	D1	Captive Contact, Gold Plt. Body	<b>901-9215</b>	1
	.575(14.6)	.375(9.5)	P13	D1	Captive Contact, Passivated Body	<b>901-9215-SF</b>	1
Slot .015*(0.4mm) Wide	.425(10.8)	.375(9.5)	P9	D1	Captive Contact, Gold Plt. Body	<b>901-9204-4CC</b>	3
	.425(10.8)	.375(9.5)	P12	D1	Captive Contact, Passivated Body	<b>901-9204-4CCSF</b>	3
Slot .030*(0.8mm) Wide	.425(10.8)	.375(9.5)	P12	D1	Captive Contact, Passivated Body	<b>901-9204-3CCSF</b>	3
Blunt Post .115*(2.9mm) Long	.490(12.4)	.375(9.5)	P13	D1	Captive Contact, Passivated Body	<b>901-9758</b>	2

# SMA Panel Jack Receptacles – 4-hole Flange

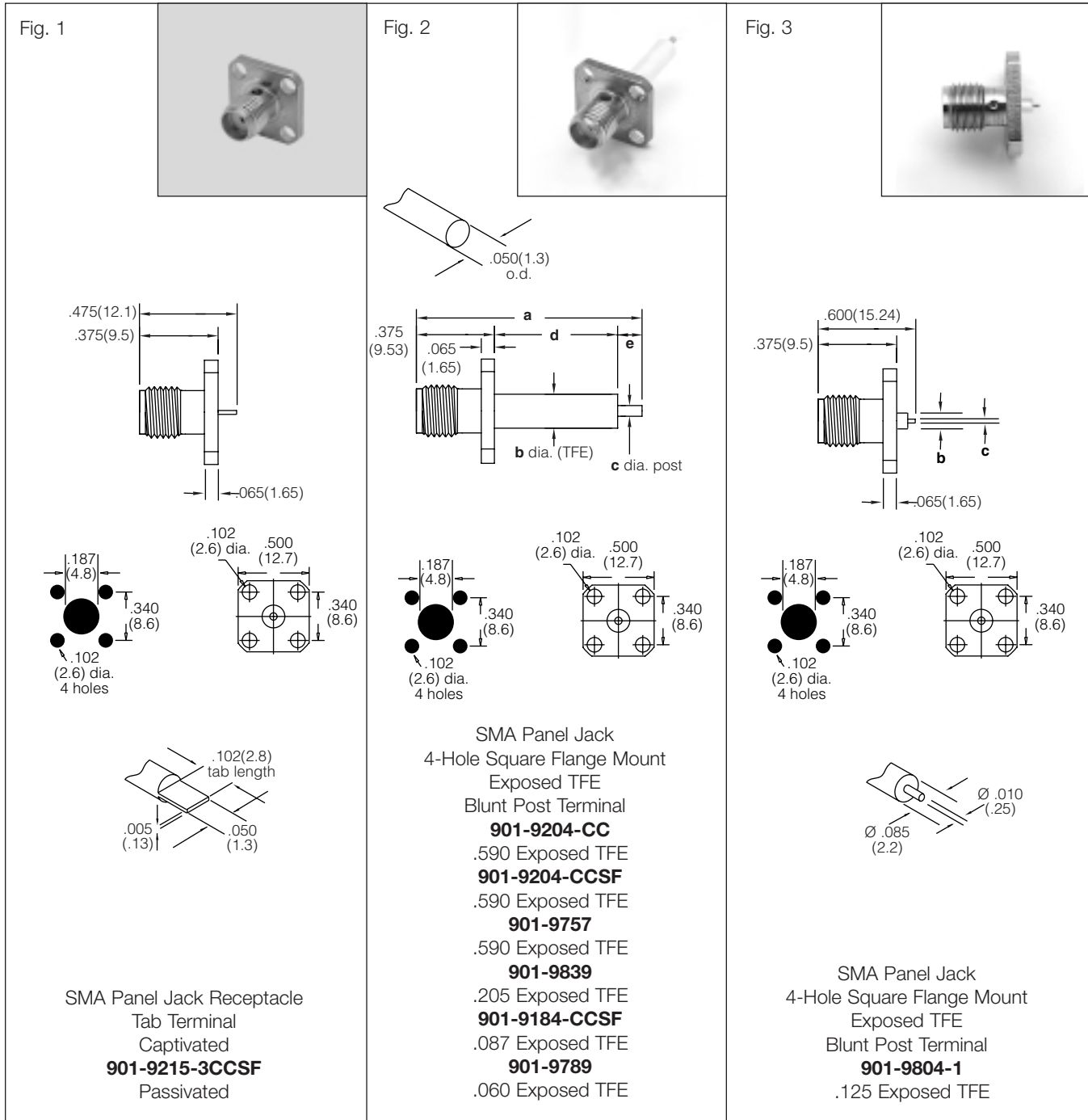

## SMA PANEL JACK RECEPTACLES – 4-hole square flange mount

Terminal Type	Dimensions In. (mm)					Plt.	Ins.	Amphenol Number	Fig.
	a	b	c	d	e				
Blunt Post	1.08(27.4)	.162(4.1) dia	.050(1.3) dia	.590(15.0)	.115(2.9)	P9	D1	<b>901-9204-CC</b>	2
	1.08(27.4)	.162(4.1) dia	.050(1.3) dia	.590(15.0)	.115(2.9)	P13	D1	<b>901-9204-CCSF</b>	2
Blunt Post	1.08(27.4)	.162(4.1) dia	.050(1.3) dia	.590(15.0)	.115(2.9)	P13	D1	<b>901-9757</b>	2
Blunt Post	.640(16.2)	.162(4.1) dia	.050(1.3) dia	.205(5.2)	.060(1.5)	P13	D1	<b>901-9839</b>	2
Blunt Post	.562(14.3)	.162(4.1) dia	.050(1.3) dia	.087(2.2)	.100(2.5)	P13	D1	<b>901-9184-CCSF</b>	2
Blunt Post	.560(14.2)	.162(4.1) dia	.050(1.3) dia	.060(1.5)	.125(3.2)	P13	D1	<b>901-9789</b>	2
Blunt Post, Solder Dipped	—	.085(2.2) dia	.010(0.3) dia	—	—	P13	D1	<b>901-9804-1</b>	3
Tab ± .100 (2.5) Long	Captive Contact, Flush TFE, Conforms to M83517/1-31004 (NQ)*					P12	D1	<b>901-9215-3CCSF</b>	1

# Panel Plug Receptacles – 4-hole Flange

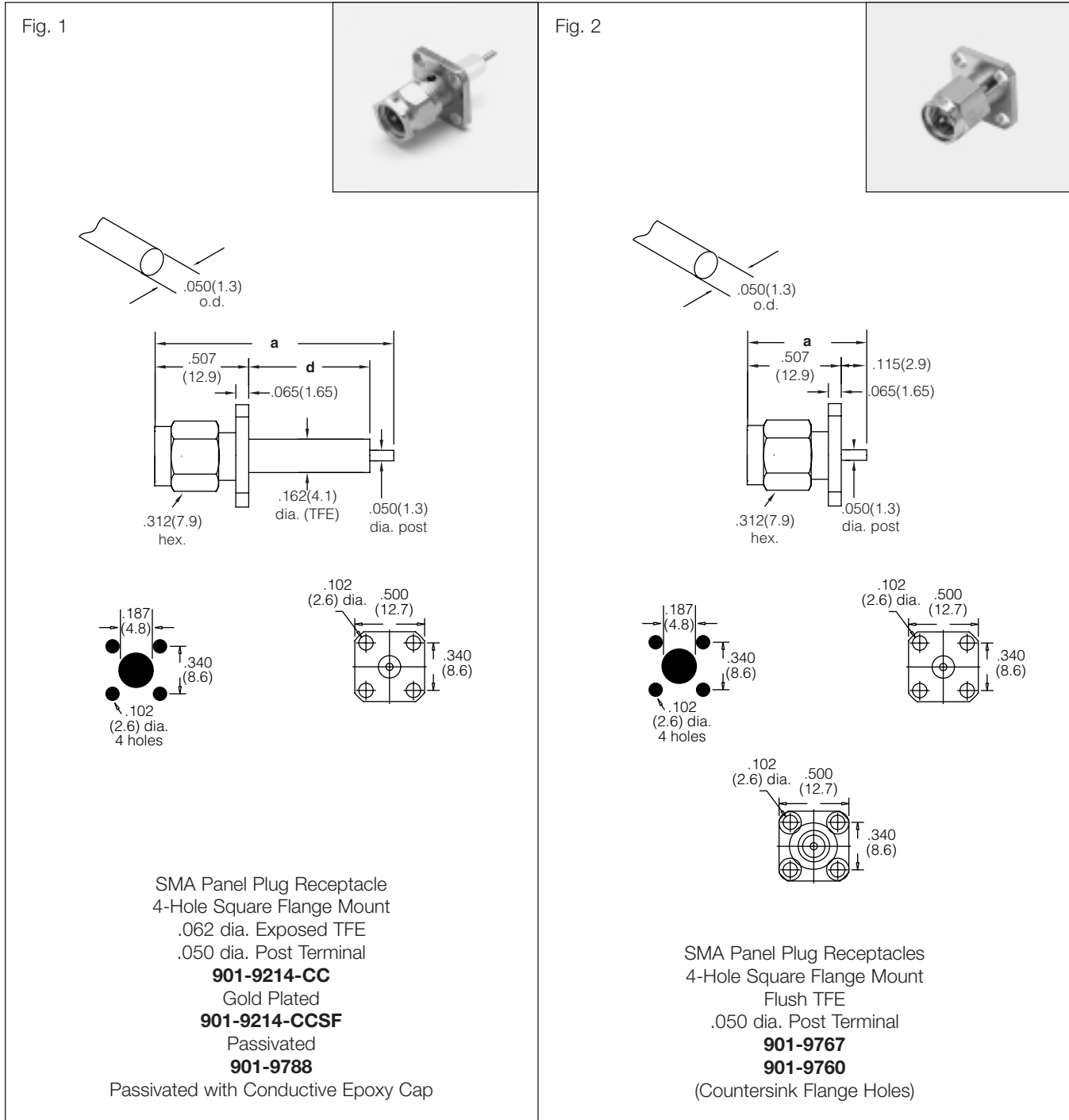

## SMA PANEL PLUG RECEPTACLES – 4-hole square flange

Description	Dim Inches (mm)		Plt.	Ins.	Construction Notes		Amphenol Number	Fig.
	a	d						
Blunt Post/.158(4.0) Long	.995(25.3)	.330(8.4)	P9	D1	Captive Contact/.330(8.4) Exposed TFE	Gold Plated Body	<b>901-9214-CC</b>	1
Blunt Post/.158(4.0) Long	.995(25.3)	.330(8.4)	P12	D1	Captive Contact/.330(8.4) Exposed TFE	Passivated Body	<b>901-9214-CCSF</b>	1
Blunt Post/.115(2.9) Long	1.21(30.8)	.590(15.0)	P13	D1	Captive Contact/.590(15.0) Exposed TFE	Passivated Body	<b>901-9788</b>	1
Blunt Post/.115(2.9) Long	.622(15.8)	—	P13	D1	Captive Contact/Flush TFE	Passivated Body	<b>901-9767</b>	2
Blunt Post/.115(2.9) Long	.622(15.8)	—	P13	D1	Captive Contact/Flush TFE C'sink Flange Holes	Passivated Body	<b>901-9760</b>	2

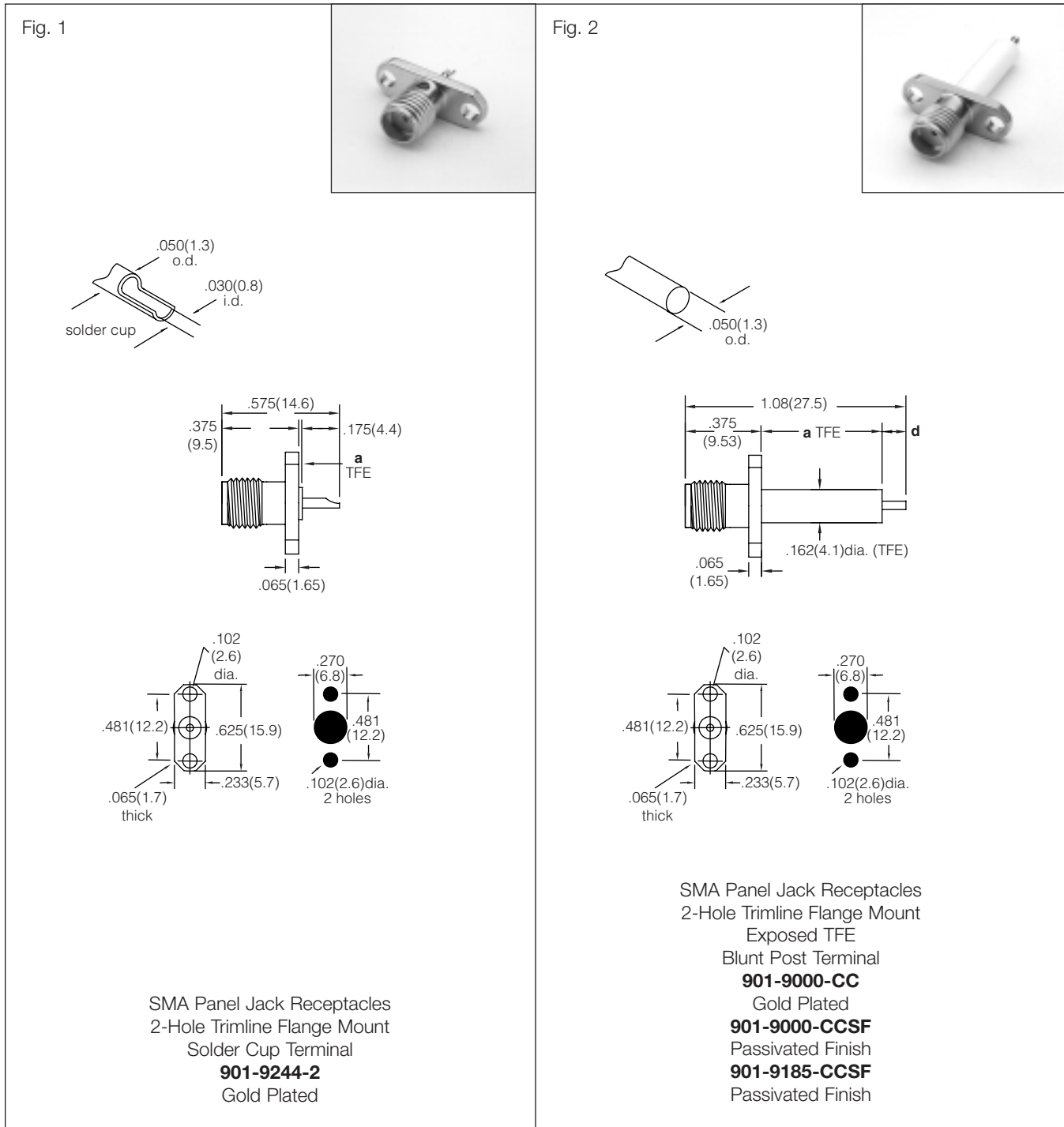

# Panel Jack Receptacles – 2-hole Flange



## SMA PANEL JACK RECEPTACLES – 2-hole trimline flange

Description	Terminal Type	Plt.	Ins.	Construction Notes	Amphenol Number	Fig.
Panel Jack Receptacle	Solder Cup	P10	D1	Captive Contact/ a=.025" (0.6mm) Exposed TFE	Gold Plated <b>901-9244-2</b>	1
Panel Jack Receptacle	Blunt Post	P10	D1	Captive Contact/d=.117(3.0) Long Post	Gold Plated <b>901-9000-CC</b>	2
		P13	D1	a=.590" (15.0mm) Exposed TFE	Passivated <b>901-9000-CCSF</b>	2
Panel Jack Receptacle	Blunt Post	P13	D1	Captive Contact/d=.103(2.6) Long Post a=.334" (8.5mm) Exposed TFE	Passivated <b>901-9185-CCSF</b>	2

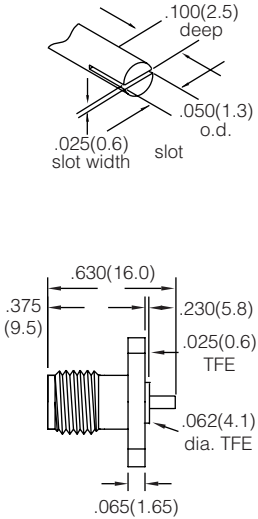
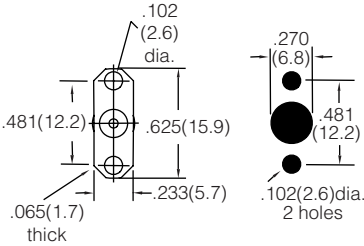
# Panel Jack Receptacles – 2-hole Flange

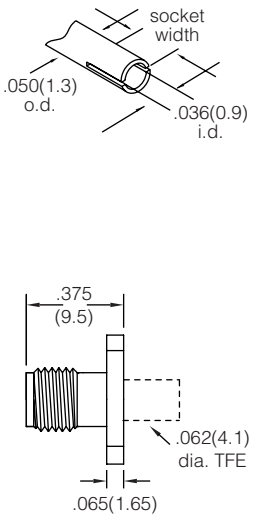
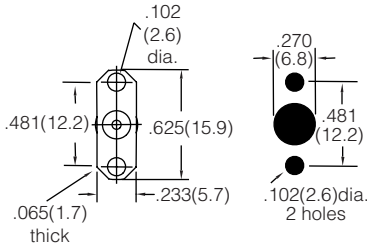





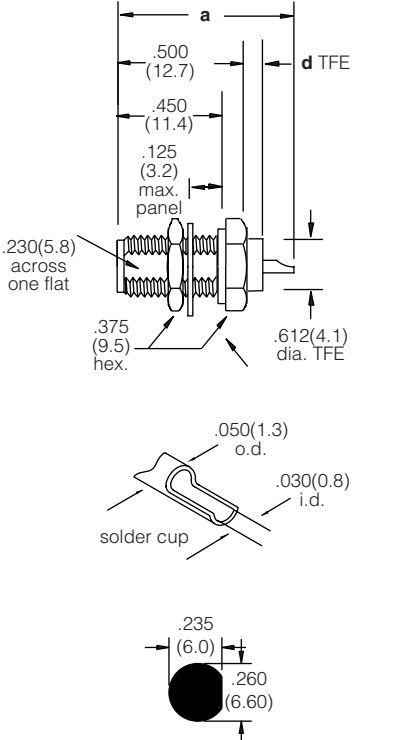

<p>Fig. 1</p>    <p style="text-align: center;">.223" Wide 2-Hole Trimline Flange</p> <p style="text-align: center;">SMA Panel Jack Receptacles Slot Terminal <b>901-9244-1</b> ‡ Gold Plated <b>901-9244-1SF</b> ‡ Passivated Finish</p>	<p>Fig. 2</p>    <p style="text-align: center;">.223" Wide 2-Hole Trimline Flange</p> <p style="text-align: center;">SMA Panel Jack Receptacles Socket Terminal <b>901-9814</b> Flush TFE, Conductive Epoxy Cap <b>901-9770</b> .185 Exposed TFE</p>
--	--

## SMA PANEL RECEPTACLES – 2-hole trimline flange

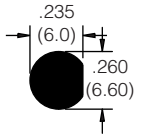
Description	Terminal Type	Pit.	Ins.	Construction Notes		Amphenol Number	Fig.
Panel Jack Receptacle	Slot .025" (0.6mm) wide	P9	D1	Contact Shipped Unassembled/ .025" (0.6 mm) Exposed TFE	Gold Plated	‡ <b>901-9244-1</b>	1
		P13	D1		Passivated	‡ <b>901-9244-1SF</b>	1
Panel Jack Receptacle	Socket	P13	D1	Flush TFE	Passivated Body	<b>901-9814</b>	2
Panel Jack Receptacle	Socket	P13	D1	.085 Exposed TFE	Passivated Body	<b>901-9770</b>	2

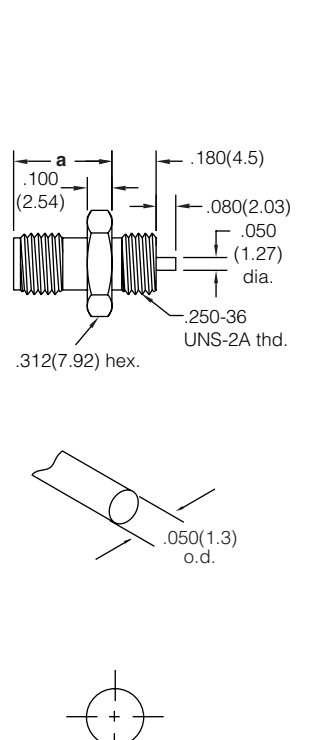
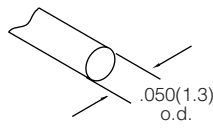
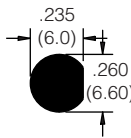
‡ Contact shipped unassembled. User has option for slot orientation

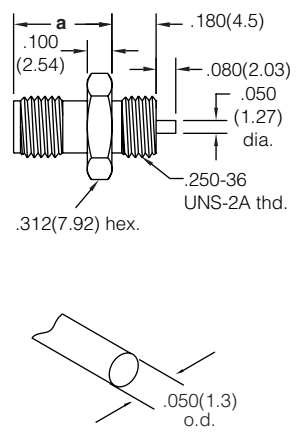
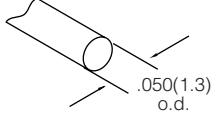

<p>Fig. 1</p>     <p>SMA Bulkhead Receptacle Rear Mount Solder Cup Terminal Hex Flange <b>901-9211</b> Gold Plated, Epoxy Captivated <b>901-9211-SF</b> Passivated Finish, Epoxy Captivated <b>901-10032-SF</b> Gold Plated, Mechanically Captivated <b>901-10032</b> Passivated Finish, Mechanically Captivated</p>	<p>Fig. 2</p>     <p>SMA Bulkhead Receptacle Front or Rear Mount Blunt Post Terminal Gold Plated <b>901-9220</b> Passivated Finish <b>901-9835</b> Gold Plated/Flush TFE</p>	<p>Fig. 3</p>     <p>SMA Bulkhead Receptacle Front Mount Post Terminal Hex Flange <b>901-9841</b> Gold Plated without Nut &amp; Washer</p>
---	---	--

## SMA BULKHEAD RECEPTACLES – female contacts

Description	Terminal Type	Plt.	Ins.	Construction Notes		Dim Inches (mm)		Amphenol Number	Fig.
						a	d		
Rear Mount/ Hex Flange	Solder Cup	P10	D1	Captive Contact/ .066(1.7mm) Exposed TFE	Gold Plated	.668(17.0)	.066(1.7)	<b>901-9211</b>	1
	Solder Cup	P13	D1		Passivated	.668(17.0)	.066(1.7)	<b>901-9211-SF</b>	1
Front or Rear Mount	Blunt Post	P10	D1	Captive Contact/ .076(1.9mm) Exposed TFE	Gold Plated	.660(16.7)	.076(1.9)	<b>901-9220</b>	2
	Blunt Post	P13	D1		Passivated	.660(16.7)	.076(1.9)	<b>901-9220-SF</b>	2
	Blunt Post	P11	D1	Captive Contact/Flush TFE	Gold Plated	.625(15.9)	.076(1.9)	<b>901-9835</b>	2
Front Mount	Post	P11	D1	Flush TFE	Gold Plated	.400(10.2)	—	<b>901-9841</b>	3
Rear Mount Hex. Flange	Solder Cup	P10	D1	Mechanically captivated	Gold Plated	.668(17.0)	.066(1.7)	<b>901-10032</b>	1
	Solder Cup	P13	D1	Mechanically captivated	Passivated	.668(17.0)	.066(1.7)	<b>901-10032-SF</b>	1

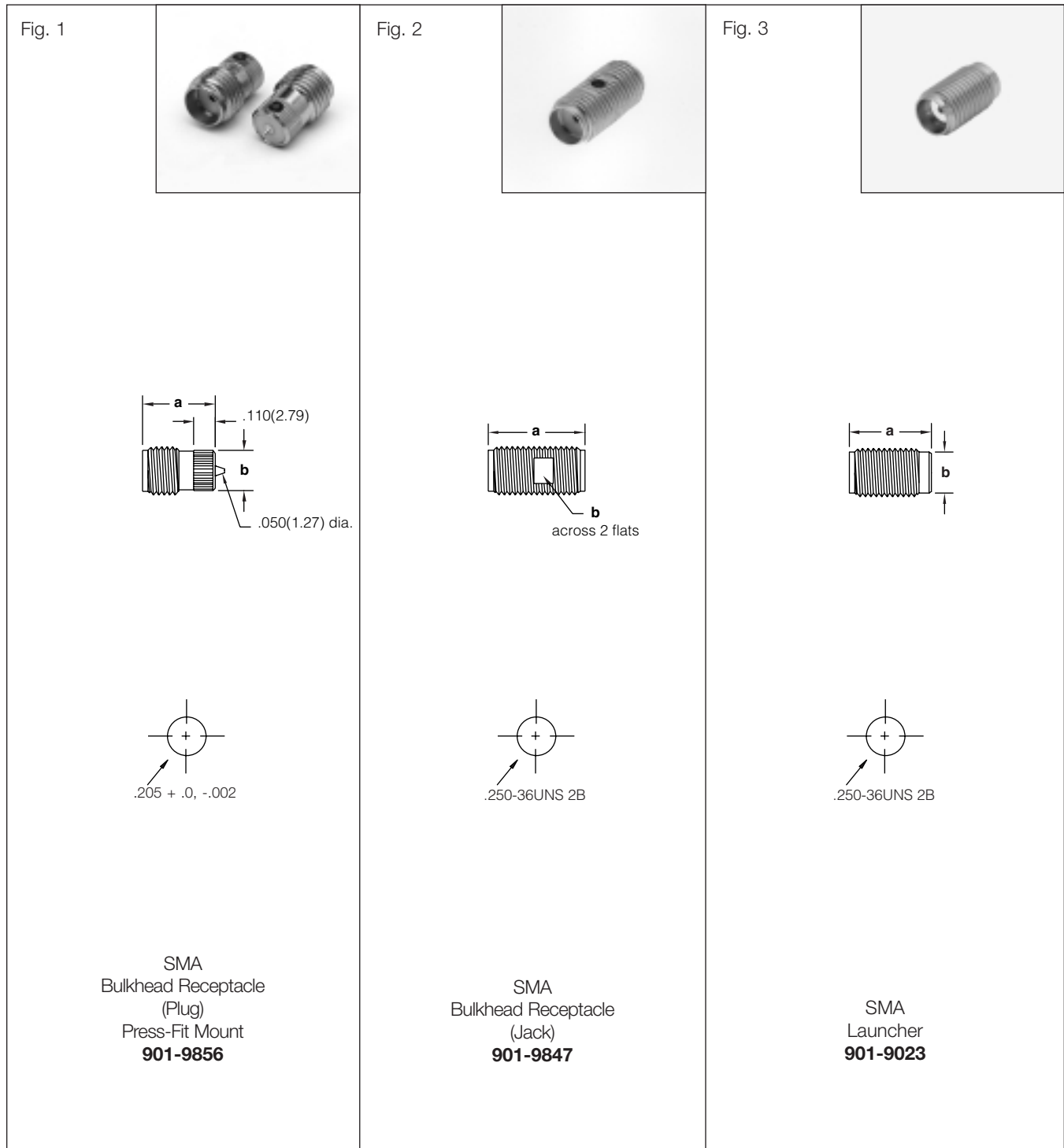





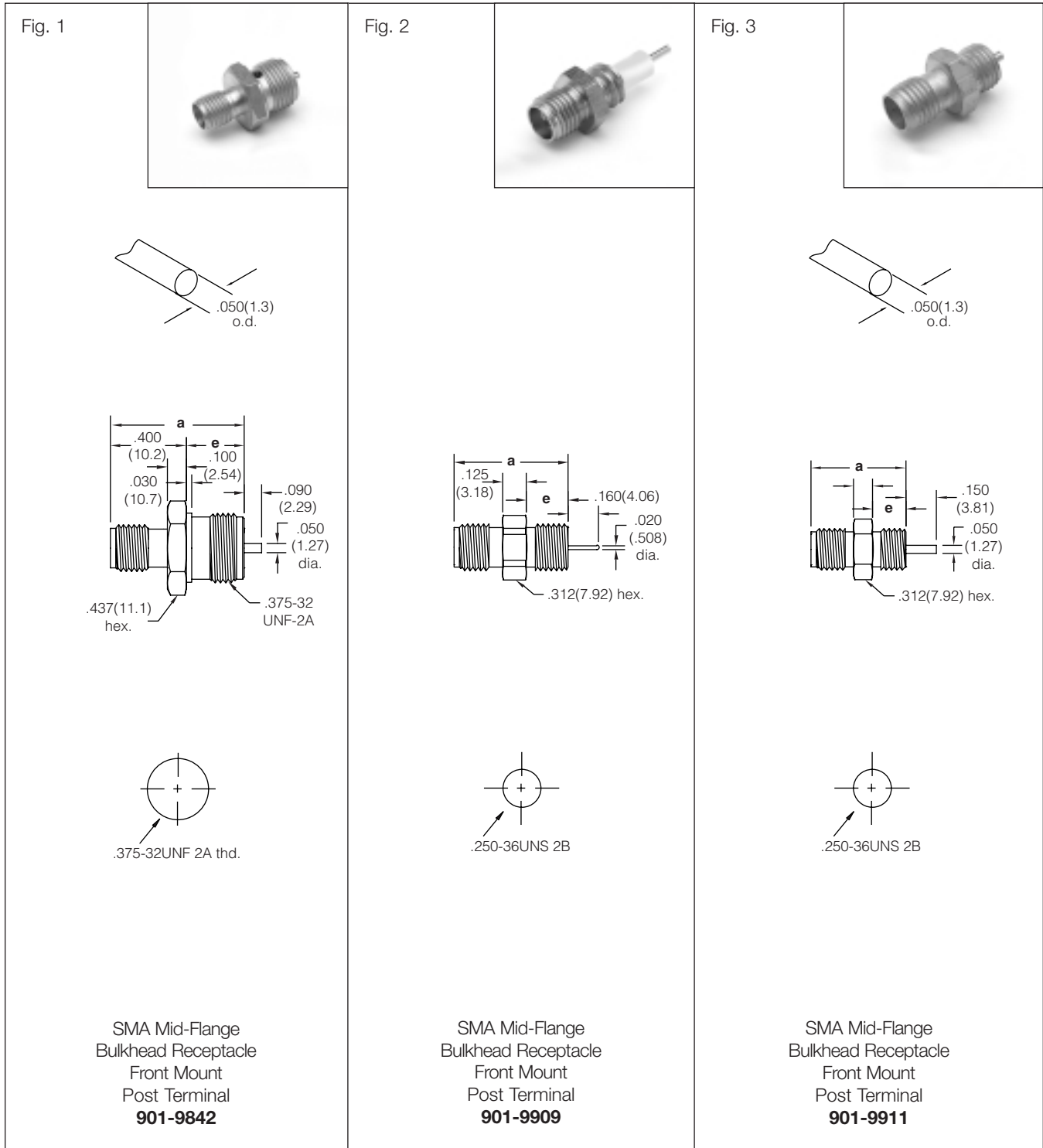

## SMA BULKHEAD RECEPTACLES – female contacts

Description	Terminal Type	Plt.	Ins.	Construction Notes		Dim Inches (mm)		Amphenol Number	Fig.
						a	b		
Press-Fit	Tab	P13	D1	Flush TFE	Passivated	.375(9.53)	.206(5.23)	<b>901-9856</b>	1
Front or Rear Mount	Socket	P13	D1	Flush TFE	Passivated	.500(12.7)	.210(5.33)	<b>901-9847</b>	2
	Socket	P13	D1	Flush TFE/ w/o Nut & Washer	Passivated	.425(10.8)	.210(5.33)	<b>901-9023</b>	3

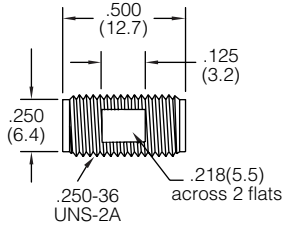

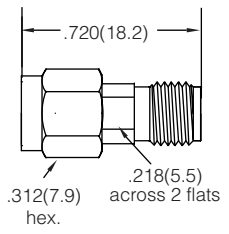

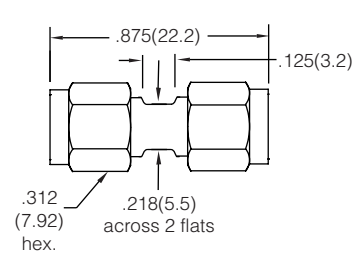
## SMA MID-FLANGE BULKHEAD RECEPTACLES – female contacts

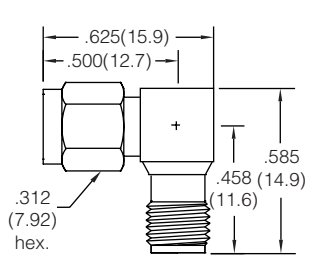
Description	Terminal Type	Pit.	Ins.	Construction Notes	Dim Inches (mm)		Amphenol Number	Fig.
					a	e		
Front Mount	Blunt Post	P13	D1	Flush TFE	Passivated	.706(17.9)   .306(7.77)	<b>901-9842</b>	1
Front Mount	Blunt Post	P13	D1	.020 Spherical Radius	Passivated	.600(15.2)   .220(5.89)	<b>901-9909</b>	2
Front Mount	Blunt Post	P12	D1	Gold over Copper Contact	Passivated	.500(12.7)   .188(4.78)	<b>901-9911</b>	3

<p>Fig. 1</p> <p>DC-18 GHz 1.14 VSWR max.</p>   <p>SMA Straight Adapter, Jack-Jack <b>901-9217</b> Gold Plated <b>901-9217-SF</b> Passivated Finish</p>	<p>Fig. 2</p> <p>DC-18 GHz 1.14 VSWR max.</p>   <p>SMA Straight Adapter, Plug-Jack <b>901-9216</b> Gold Plated <b>901-9216-SF</b> Passivated Finish</p>
<p>Fig. 3</p> <p>DC-18 GHz 1.14 VSWR max.</p>   <p>SMA Straight Adapter, Plug-Plug <b>901-9218</b> Gold Plated <b>901-9218-SF</b> Passivated Finish</p>	<p>Fig. 4</p> <p>DC-18 GHz 1.23 VSWR max.</p>   <p>SMA Angle Adapter, Plug-Jack <b>901-125-11</b> Gold Plated <b>901-125-11SF</b> (M55339/02-30001) Passivated</p>

## SMA IN-SERIES ADAPTERS

Description	Pit.	Ins	Notes	Mil. No. M55339/	Amphenol Number	Fig.
Straight Jack-Jack	P9	D1	DC-18GHz Max. VSWR 1.14 Captive Contact	—	<b>901-9217</b>	1
	P12			—	<b>901-9217-SF</b>	
Straight Plug-Jack	P9	D1	DC-18GHz Max. VSWR 1.14 Captive Contact	—	<b>901-9216</b>	2
	P12			—	<b>901-9216-SF</b>	
Straight Plug-Plug	P10	D1	DC-18GHz Max. VSWR 1.14 Captive Contact	—	<b>901-9218</b>	3
	P12			—	<b>901-9218-SF</b>	
Angle Plug-Jack	P13	D1	DC-18GHz Max. VSWR 1.23 Captive Contact	—	<b>901-125-11</b>	4
	P13			02-30001	<b>901-125-11SF</b>	

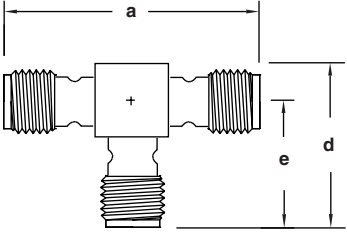
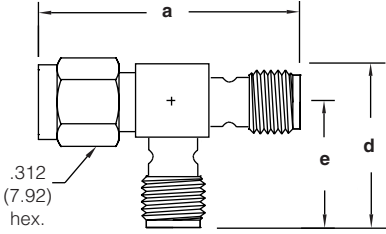
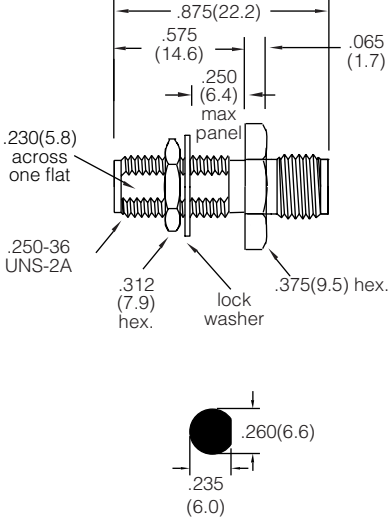
<p>Fig. 1</p> 	<p>Fig. 2</p> 	<p>Fig. 3</p> 
 <p>SMA Tee Adapter Jack-Jack-Jack <b>901-178</b> Gold Plated</p>	 <p>SMA Tee Adapter Plug-Jack-Jack <b>901-382-1</b> Gold Plated</p>	 <p>SMA Bulkhead Adapter Jack-Jack <b>901-9209-A</b> Gold Plated <b>901-9209-ASF</b> Passivated Finish</p>

## SMA IN-SERIES TEE ADAPTERS

Description	Dimensions, Inches (millimeters)			Plt.	Ins	Notes	Amphenol Number	Fig.
	a	d	e					
Tee Adapter, Jack-Jack-Jack	1.00(25.4)	.687(17.5)	.500(12.7)	P9	D1	BeCu Body	<b>901-178</b>	1
Tee Adapter, Plug-Jack-Jack	1.08(27.4)	.687(17.5)	.500(12.7)	P9	D1	BeCu Body	<b>901-382-1</b>	2

## SMA IN-SERIES BULKHEAD ADAPTERS

Description	Plt.	Ins	Notes	Amphenol Number	Fig.
Bulkhead Jack-Jack Front or Rear Mount	P11	D1	DC-18GHz Max. VSWR 1.14 Captive Contact	<b>901-9209-A</b>	3
	P13			<b>901-9209-ASF</b>	

Amphenol has available a line of 50 ohm SMA brass connectors as a cost effective solution for applications where stainless steel construction is not required. This gives the design engineer flexibility with performance to complete projects with world class components.

Amphenol series 901 SMA brass connectors are semi-precision, subminiature units which provide electrical performance from DC to 18 GHz. These high performance connectors are compact in size and mechanically have outstanding durability.

### Features/Benefits

- Amphenol brass SMA connectors feature pre-assembled captive center contacts, brass body and coupling nuts.
- Connectors are built in accordance with MIL-C-39012.
- Can be mated with all connectors which meet the military specification mating diameters regardless of manufacturer.
- Available for .085" and .141" diameter semi-rigid cables and all the standard flexible cables including double shielded RG-316.
- Connectors are adaptable to the interconnection requirements of both systems and components.

## SPECIFICATIONS\*

### ELECTRICAL

Impedance	50 ohms
Frequency range	.141" & .085" O.D. copper jacket semi-rigid cable. 0-18GHz. Flexible cables: 0-12.4 GHz.
Voltage rating	RG-58,141,142: 500 volts peak RG-174, 188, 316:, 375 volts peak
Dielectric withstanding voltage	.141" & RG-58 group: 1,000 VRMS. .085" & RG-316 group: 750 VRMS.
VSWR (straight connectors)	.141" O.D. semi-rigid cable: 1.05 + .005 f RG-174 group: 1.15 + .02 f RG-58 group: 1.15 + .01 f RG-178 group: 1.20 + .025 f
Contact resistance	Center: 2.0 milliohms Body: 2.0 milliohms Braid to body: 0.5 milliohms
Insulation resistance:	5000 megohms
RF leakage	-90 dB min. at 2.3 GHz
Insertion loss:	dB max. = $.06 \sqrt{f(\text{GHz})}$ Test frequency @ 6.0 GHz

### MATERIAL



Bodies, coupling nuts, other metal parts (except as noted)	Brass per QQ-B-626
Contacts Male: Female:	Brass Beryllium copper, heat treated
Plating: Center contacts,	.000030" min. gold
Plating: Other metal parts	Standard .000010" gold or nickel plated
Insulators	TFE fluorocarbon
Gaskets	Silicone rubber
Crimp ferrules	Seamless copper tubing alloy

### MECHANICAL‡

Mating	.250-36 Threaded coupling
Mating Torque	Minimum: 2 inch pounds 12 N.cm Recommended: 8 to 10 inch pounds 45 N.cm Maximum: 15 inch pounds 60 N.cm
Connector Durability	100 matings

\* These characteristics are typical and may not apply to all connectors.

‡ Pressure applied on an SMA outer contact is extremely high; therefore inadequate torque of connector body will result in a slight deformation of the outer contact. Reflections will appear above 2GHz.

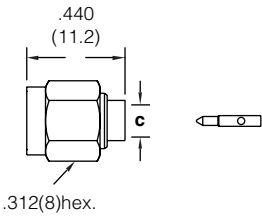
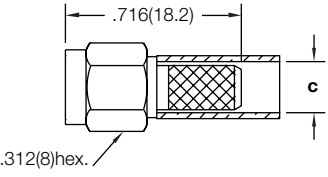
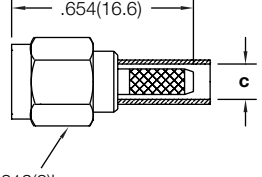
<p>Fig. 1</p> 	<p>Fig. 2</p> 	<p>Fig. 3</p> 
 <p>.440 (11.2)</p> <p>.312(8)hex.</p> <p>c</p> <p>SMA Solder Plug  <b>901-9868-RFX▲</b>          Gold Plated for .141" S/R  <b>901-9867-RFX▲</b>          Gold Plated for .085" S/R</p>	 <p>.716(18.2)</p> <p>.312(8)hex.</p> <p>c</p> <p>SMA Crimp Plug          Captivated Center Contact  <b>901-9870▲</b>          Gold Plated for RG-58  <b>901-9871▲</b>          Gold Plated for RG-223, 141  <b>901-9876-RFX▲</b>          Nickel Plated for RG-58  <b>901-10009-RFX</b>          Gold Plated for LMR 240  <b>901-10010-RFX</b>          Gold Plated for LMR 200</p>	 <p>.654(16.6)</p> <p>.312(8)hex.</p> <p>c</p> <p>SMA Crimp Plug          Captivated Center Contact  <b>901-9877-RFX▲</b>          Nickel Plated for RG-174, 188, 316  <b>901-9916</b>          Gold Plated for RG-174, 188, 316  <b>901-10024-RFX</b>          Gold Plated for RD-174, 188, 316  <b>901-10025-RFX</b>          Nickel Plated for RD-174, 188, 316</p>

## SMA BRASS PLUGS

Cable RG-/U	Connector Description	Cable Attachment		c Dia In. (mm)	CAI	Ins.	Notes	Amphenol Number	Fig.
		Outer	Inner						
58	Plug	Crimp	Solder	.210(5.3)	C53	D1	Captive Contact	▲ 901-9870	2
58	Plug	Crimp	Solder	.210(5.3)	C53	D1	Captive Contact	▲ 901-9876-RFX	2
174, 188, 316	Plug	Crimp	Solder	.128(3.3)	C57	D1	Captive Contact	▲ 901-9877-RFX	3
RD 174, 188, 316	Plug	Crimp	Solder	.128(3.3)	C57	D1	Captive Contact	901-9916	3
RD 174, 188, 316	Plug	Crimp	Solder	.128(3.3)	C57	D1	Captive Contact	901-10024-RFX	3
174, 188, 316	Plug	Crimp	Solder	.128(3.3)	C57	D1	Captive Contact	901-10025-RFX	3
141, 223	Plug	Crimp	Solder	.220(5.6)	C53	D1	Captive Contact	▲ 901-9871	2
.085" S/R	Plug	Solder	Solder	.090(2.3)	C47	D1	—	▲ 901-9867-RFX	1
.141" S/R	Plug	Solder	Solder	.145(3.7)	C47	D1	—	▲ 901-9868-RFX	1
LMR 240	Plug	Crimp	Solder	.261(6.6)	C53	D1	Captive Contact	901-10009-RFX	2
LMR 200	Plug	Crimp	Solder	.206(5.2)	C53	D1	Captive Contact	901-10010-RFX	2

▲ distributor stocked

# SMA Brass Angle Plugs & Bulkhead Jacks

<p>Fig. 1</p> <p>SMA Angle Plug, Crimp  <b>901-9872▲</b>          Gold Plated for RG-174, 188, 316  <b>901-9873▲</b>          Gold Plated for RG-58  <b>901-9874▲</b>          Gold Plated for RG-141, 223  <b>901-9880-RFX▲</b>          Nickel Plated for RG-58  <b>901-9881-RFX▲</b>          Nickel Plated for RG-174, 188, 316  <b>901-10028-RFX</b>          Gold Plated for RD-174, 188, 316  <b>901-10029-RFX</b>          Nickel Plated for RD-174, 188, 316</p>		<p>Fig. 2</p> <p>SMA Low Profile Angle Plug, Crimp  <b>901-9902</b>          Nickel Plated for RG-141, 223</p>	
<p>Fig. 3</p> <p>SMA Bulkhead Jack, Crimp  <b>901-9875▲</b>          Gold Plated for RG-174, 188, 316  <b>901-9879-RFX▲</b>          Nickel Plated for RG-174, 188, 316</p>		<p>Fig. 4</p> <p>SMA Bulkhead Jack with O-Ring  <b>901-10013-RFX</b>          RG-174, 188, 316</p>	

## SMA BRASS ANGLE PLUGS

Cable RG-/U	Connector Description	Cable Attachment		c Dia In. (mm)	CAI	Ins.	Notes	Amphenol Number	Fig.
		Outer	Inner						
58	Angle Plug	Crimp	Solder	.210(5.3)	C53	D1	Gold Plated Body	▲ <a href="#">901-9873</a>	1
	Angle Plug	Crimp	Solder	.210(5.3)	C53	D1	Nickel Plated Body	▲ <a href="#">901-9880-RFX</a>	1
174, 188, 316	Angle Plug	Crimp	Solder	.128(3.3)	C57	D1	Nickel Plated Body	▲ <a href="#">901-9881-RFX</a>	1
	Angle Plug	Crimp	Solder	.128(3.3)	C57	D1	Gold Plated Body	▲ <a href="#">901-9872</a>	1
	Angle Plug	Crimp	Solder	.128(3.3)	C57	D1	Gold Plated Body	<a href="#">901-10028-RFX</a>	1
	Angle Plug	Crimp	Solder	.128(3.3)	C57	D1	Nickel Plated Body	<a href="#">901-10029-RFX</a>	1
141, 223	Angle Plug	Crimp	Solder	.220(5.6)	C53	D1	Gold Plated Body	▲ <a href="#">901-9874</a>	1
141, 223	Low Profile Angle Plug	Crimp	Solder	.220(5.6)	C53	D1	Plated Body	<a href="#">901-9902</a>	2

## SMA BRASS BULKHEAD JACKS

Cable RG-/U	Connector Description	Cable Attachment		c Dia. In. (mm)	CAI	Ins.	Notes	Amphenol Number	Fig.
		Outer	Inner						
174, 188, 316	Bulkhead Jack	Crimp	Solder	.128(3.3)	C53	D1	Gold Plated Body	▲ <a href="#">901-9875</a>	3
	Bulkhead Jack	Crimp	Solder	.128(3.3)	C53	D1	Nickel Plated Body	▲ <a href="#">901-9879-RFX</a>	3
	Bulkhead Jack	Crimp	Solder	.128(3.3)	C53	D1	Nickel Plated Body	<a href="#">901-10013-RFX</a>	4

▲ distributor stocked



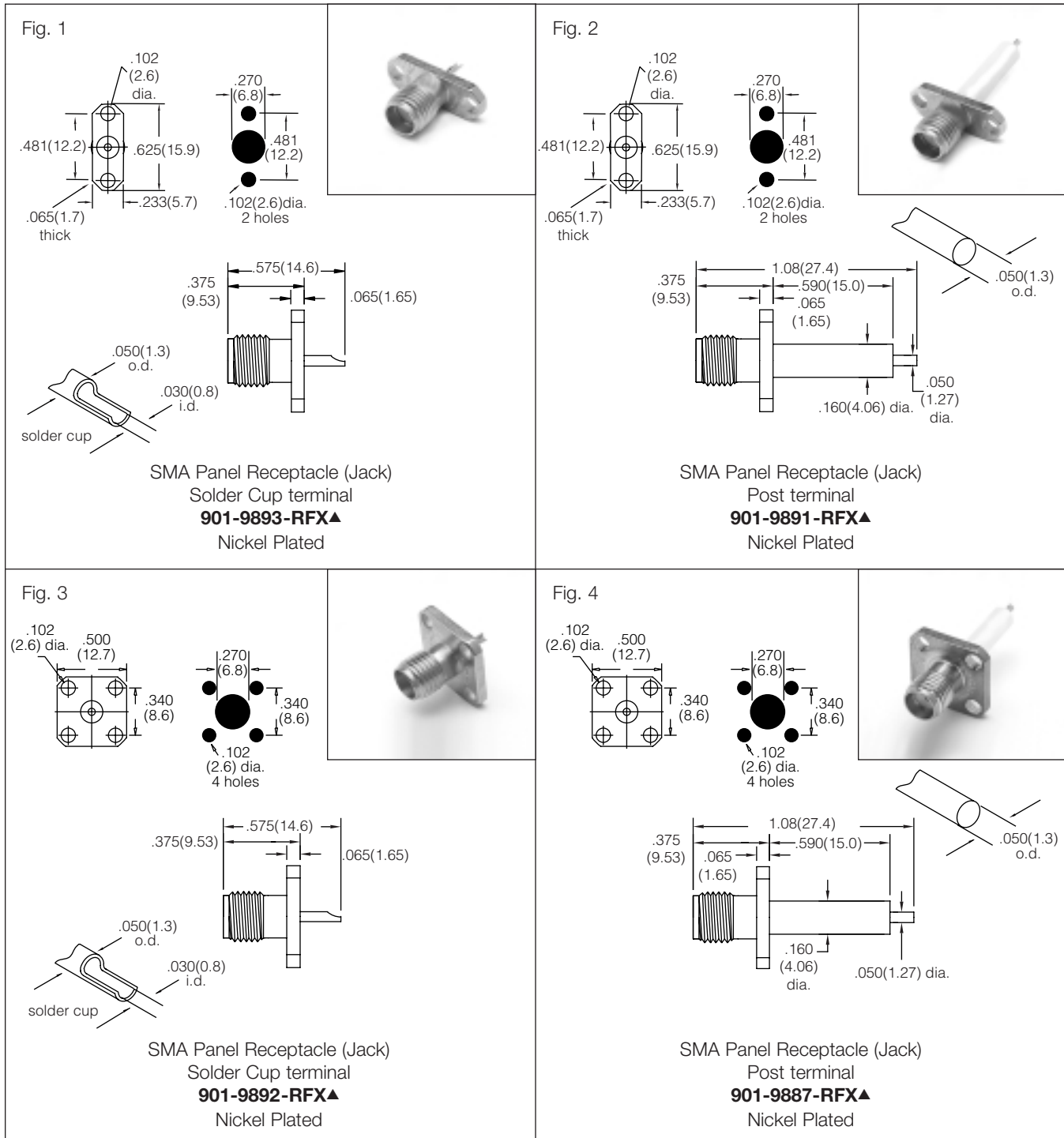

## SMA BRASS PANEL JACK RECEPTACLES

Connector Description	Terminal Type	Ins	Construction Notes	Amphenol Number	Fig.
Panel Receptacle (Jack)	Solder Cup	D1	Nickel Plated Body	▲ <a href="#">901-9893-RFX</a>	1
Panel Receptacle (Jack)	Post	D1	Nickel Plated Body	▲ <a href="#">901-9891-RFX</a>	2
Panel Receptacle (Jack)	Solder Cup	D1	Nickel Plated Body	▲ <a href="#">901-9892-RFX</a>	3
Panel Receptacle (Jack)	Post	D1	Nickel Plated Body	▲ <a href="#">901-9887-RFX</a>	4

▲ distributor stocked

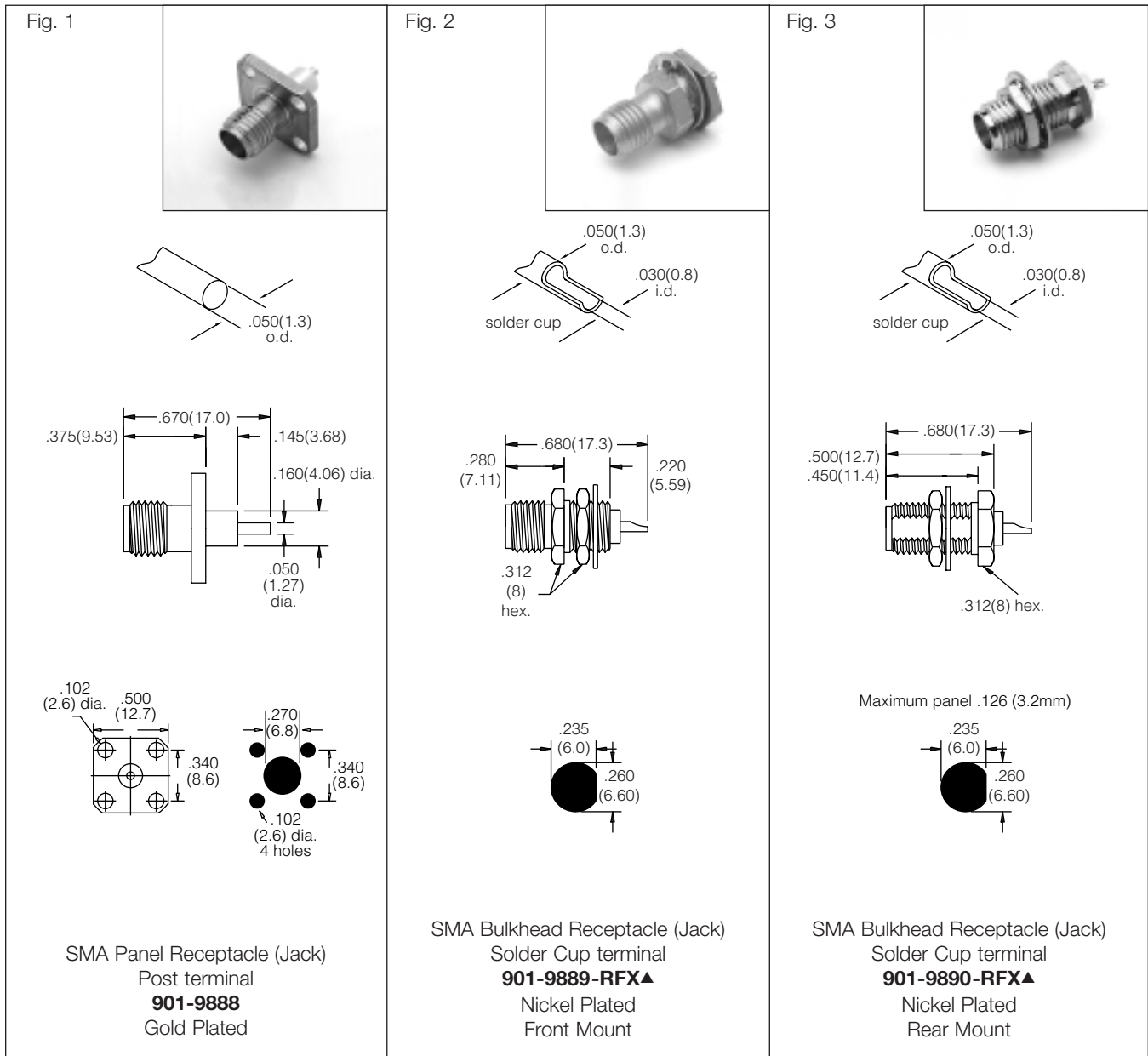

## SMA BRASS PANEL JACK RECEPTACLES

Connector Description	Terminal Type	Ins	Construction Notes	Amphenol Number	Fig.
Panel Receptacle (Jack)	Post	D1	Gold Plated Body	<b>901-9888</b>	1

## SMA BRASS BULKHEAD RECEPTACLES

Connector Description	Terminal Type	Ins	Construction Notes	Amphenol Number	Fig.
Bulkhead Receptacle (Jack), Front Mount	Solder Cup	D1	Nickel Plated Body	<b>▲ 901-9889-RFX</b>	2
Bulkhead Receptacle (Jack), Rear Mount	Solder Cup	D1	Nickel Plated Body	<b>▲ 901-9890-RFX</b>	3

▲ distributor stocked

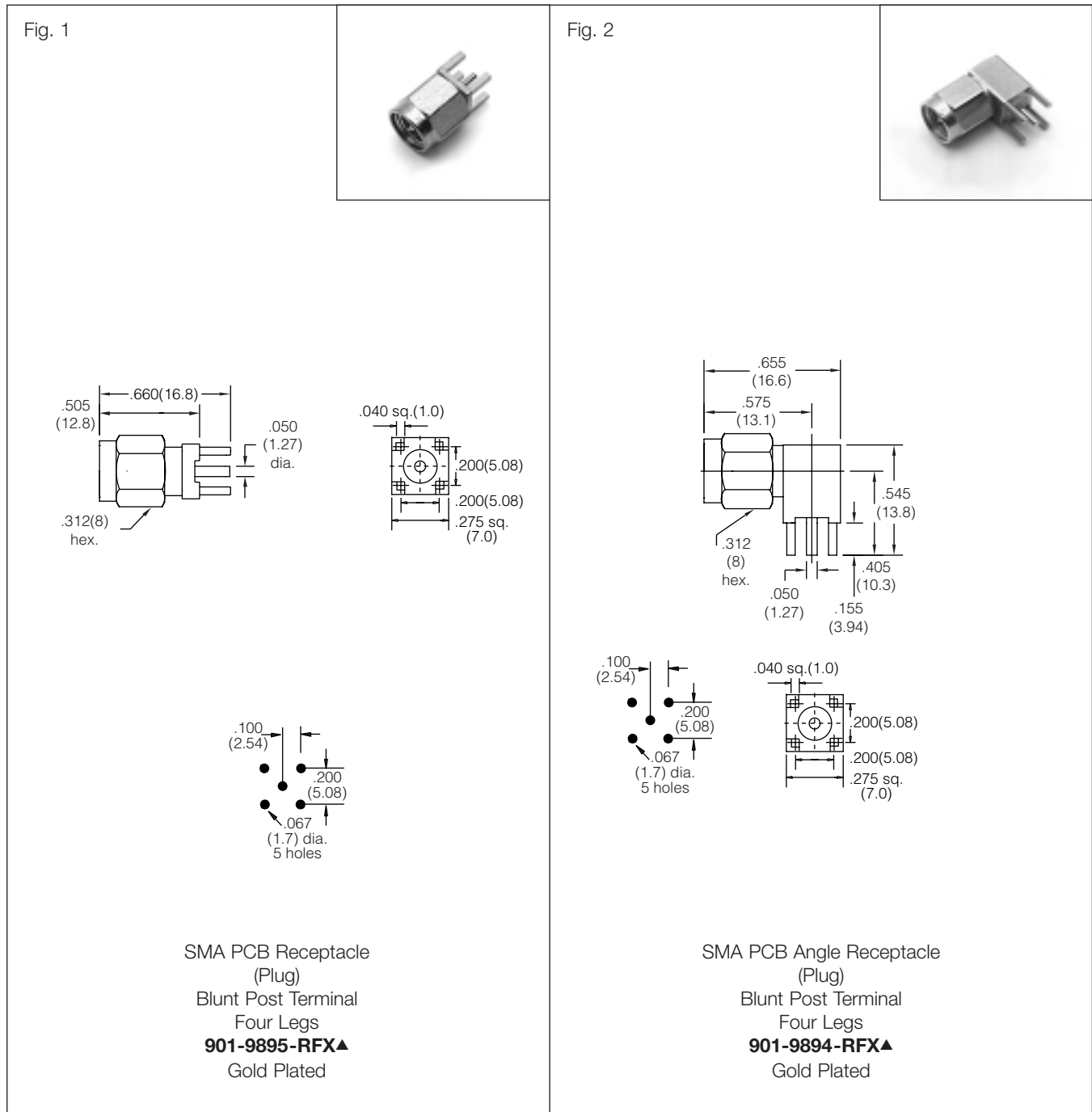

## SMA BRASS PRINTED CIRCUIT BOARD PLUG RECEPTACLES

Connector Description	Terminal Type	Ins	Construction Notes	Amphenol Number	Fig.
PCB Receptacle (P)/ Four Legs	Blunt Post	D1	Gold Plated Body	▲ <b>901-9895-RFX</b>	1
PCB Angle Receptacle (P)/ Four Legs	Blunt Post	D1	Gold Plated Body	▲ <b>901-9894-RFX</b>	2

▲ distributor stocked

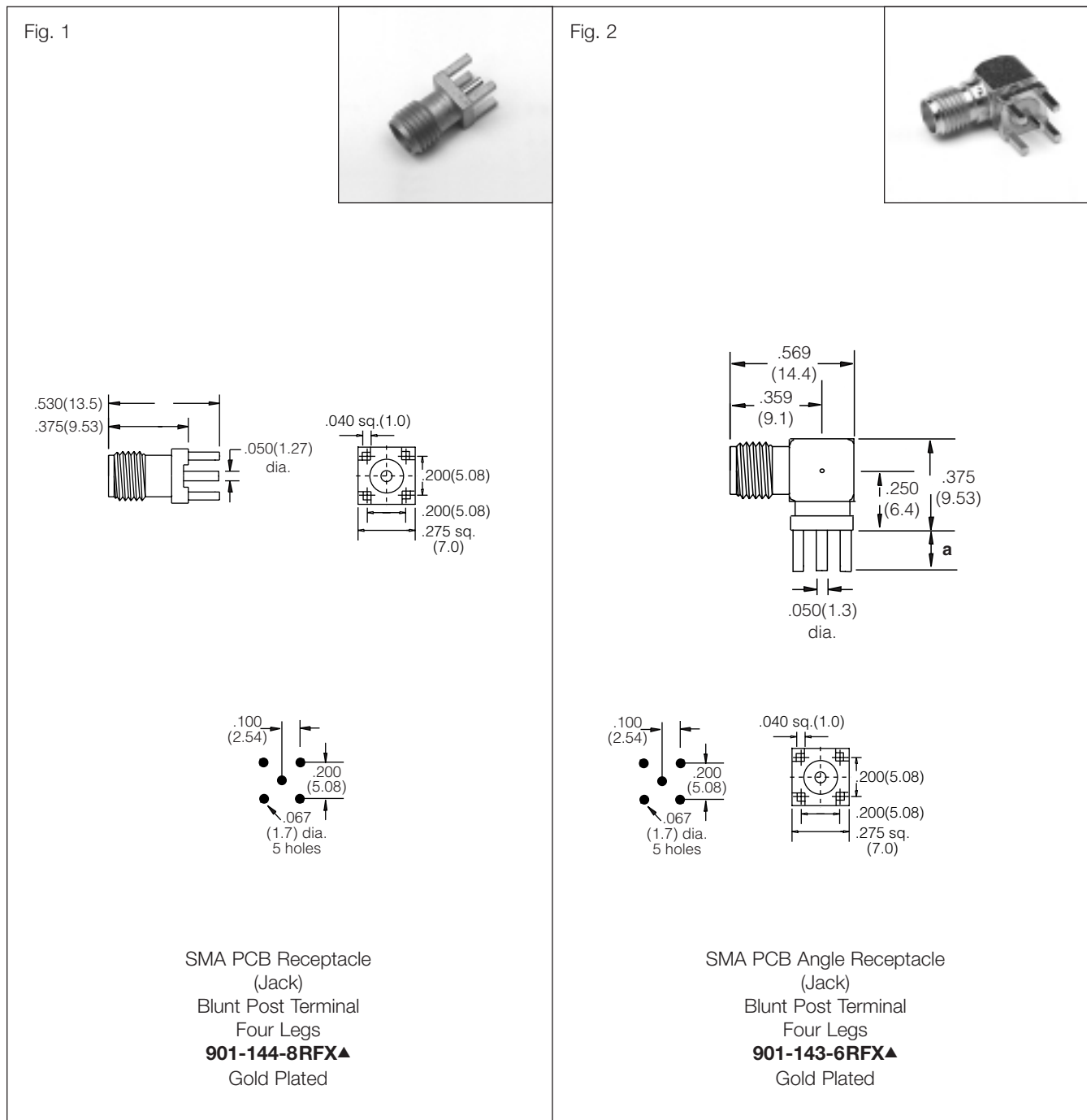

## SMA BRASS PRINTED CIRCUIT BOARD JACK RECEPTACLES

Connector Description	Terminal Type	Ins	Construction Notes	Amphenol Number	Fig.
PCB Receptacle (J)/ Four Legs	Blunt Post	D1	Gold Plated Body	▲ <b>901-144-8RFX</b>	1
PCB Angle Receptacle (J)/ Four Legs	Blunt Post	D1	Gold Plated Body	▲ <b>901-143-6RFX</b>	2

▲ distributor stocked

For phase array radar, test equipment, ILS landing systems and other instrumentation using phase matching techniques, these SMA connectors for semi-rigid coaxial cables and the SMA plug-to-Jack adapter offer a precise and simple means of phase adjustment for microwave devices.

### Features/Benefits

- Connectors incorporate a threaded interconnection of variable length.
  - Adjustment nut creates incremental changes in connector length and angle.
  - Proper phase setting for each cable is maintained by connector locking-nuts.
- (For example, one revolution of the adjustment nut results in a phase angle change of 5.7° for a 9 GHz signal [0.636 x 9]°.)*
- Connectors provide ease of mechanical screw adjustments, compared to the delays and expense of laborious cable-trimming.
  - Allow phase matching to be performed at the final production stages.

### SPECIFICATIONS\*

#### ELECTRICAL

Impedance	50 ohms
Frequency range	DC-18GHz.
Insertion loss:	dB max. For Adapter 901-508 = $.1 \sqrt{f(\text{GHz})}$ For Plug 901-509 = $.08 \sqrt{f(\text{GHz})}$
VSWR	See chart below
Phase Angle Adjustment Range in degrees	For Adapter 901-508 and Plug 901-509, = $0^\circ$ to $[10 \times f(\text{GHz})]^\circ$ max
Phase Angle change per revolution of Adjustment Nut in degrees	For Adapter 901-508 and Plug 901-509, = $[0.636 \times f(\text{GHz})]^\circ$
Voltage rating	500 VRMS peak

#### MECHANICAL

Mating	Mating face dimensions compatible with the mating requirements of MIL-C-39012/55 (Type SMA)
Connector Durability	(SMA interface) 500 cycles of mating and unmating without deterioration

#### MATERIAL

Center Contact	Beryllium copper, Gold plated
Connector Body	Brass or Beryllium Copper, Gold plated
Adjusting Nuts and Locking Nuts	Brass with ASTRO plate finish
Connector Coupling Nut	Stainless Steel, Passivated
Insulation	TFE

#### SWEPT VSWR DATA

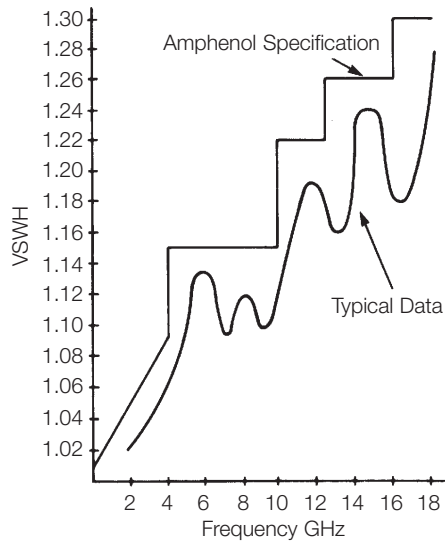

#### ENVIRONMENTAL

Shock	MIL-Std. 202 method 213 (test cond. I)
Vibration	MIL-Std. 202 method 204 (test cond. D)
Corrosion	MIL-Std. 202 method 101 (test cond. B)
Temperature range	-65°C to + 125°C

\* These characteristics are typical and may not apply to all connectors.

# SMA Phase Adjustable Connectors

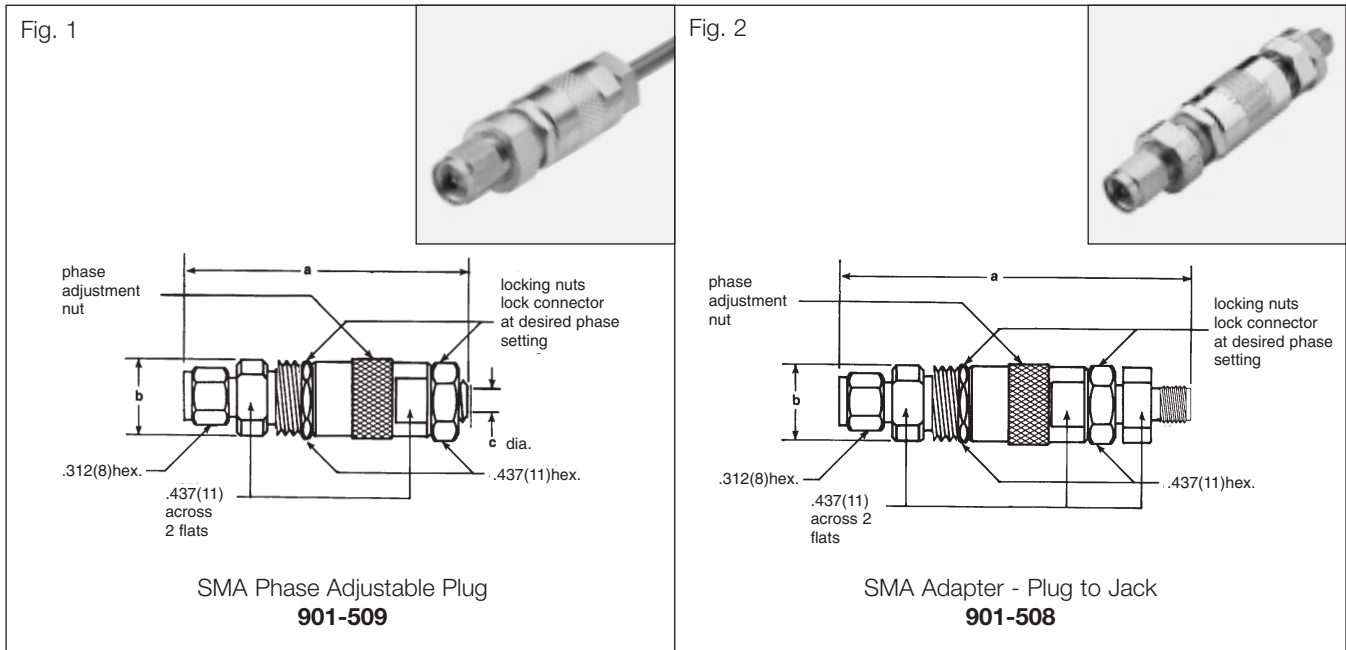

Description	Semi-Rigid Cable Size	Cable Termination	Dimensions, Inches (millimeters)			CAI	Pit.	Ins.	Amphenol Number	Fig.	
			a		b						c
			(Fully Extended)	(Fully Closed)							
Plug	.141"(3.6) dia.	Solder	2.03(51.6)	1.68(42.7)	.500(12.7)	.144(3.7)	C51	PCF	D1	901-509	1
Adapter	—	—	2.50(63.5)	2.15(54.6)	.500(12.7)	—	—	PCF	D1	901-508	2

**Description**

APC stands for Amphenol Precision Connectors and was developed by Amphenol and Hewlett-Packard engineers. The Precision family is comprised of APC-2.4, APC-3.5, APC-N, APC-7.

Amphenol's APC is the first instrument-grade coaxial connector line to achieve repeatable TE11 mode resonance-free signal transmission from DC to 50 GHz with a minimum return loss of 26 dB.

These 50 ohm connectors are designed primarily for use in test and measurement equipment where reliable performance through repeated connect/disconnect cycles is critical.

**Features/Benefits**

- Interface dimensions which minimize distortion/deterioration of the mating surfaces.
- Fixed bead-contact assembly which prevents transmission of mating torques to circuit elements.
- M7x0.75 thread for coupling durability and small overall connector size.
- Mating sequence in which the outer conductors before the center contacts meet, eliminating female center contact damage during mating.
- Plug coupling nut that extends beyond the male center contact to protect the contact while in the unmated condition.

**Application**

- Cable Assemblies
- Instrumentation
- Military
- Radio Astronomy
- Satcom



**APC 2.4**

Specifications	86
Plugs & Jacks	87
Adapters	88

**APC 3.5**

Specifications	89
Plugs & Jacks	90-92

**APC 7**

Specifications	93
Connectors	94
Components & Accessories	95

**APC N**

Specifications	96
Plugs & Jacks	97

The initial Amphenol® APC-2.4™ offering includes the male and female connectors for termination to 2.4mm rigid coaxial airline and twenty-two between-series adapters for high performance transitions from the 2.4mm interface to six other microwave coaxial connectors: APC-3.5®, APC-7®, APC-N, SMA, and the Wiltron K - connector.™\*

\*K connector is a trademark of Wiltron Co.

**Features/Benefits**

- DC to 50 GHz — provides highly accurate measurements which eliminate the need for costly waveguide components
- M7 x .075 coupling — provides durability and small overall connector size
- Mating sequence outer connector first — eliminates female center conductor contact damage during mating
- Coupling nut extends beyond male center contact — protects center conductor while in the unmated condition

**Specifications**

**ELECTRICAL**

	Test Requirement
Impedance	50 ohms
Frequency range	DC-50 GHz
Return loss (min.)	
DC to 18 GHz:	>36 dB
18 to 26.5 GHz:	>32 dB
26.5 to 50 GHz:	>26 dB
Insertion loss:	≤0.06 dB
Contact resistance	
Inner:	< 1.5 milliohms
Outer:	< 0.8 milliohms
Voltage rating:	400 Vrms
Dielectric Withstanding	
Voltage (max.):	1200 Vrms
Max. power (watts @ sea level)	1000 W/ √f (MHz)

\* These characteristics are typical and may not apply to all connectors.

**ENVIRONMENTAL**

Temperature range	-70°C to + 80°C
-------------------	-----------------

**MECHANICAL**

Mating	M7 x 0.75 threaded coupling
Recommended Mating torque	8 to 10 inch pounds (0.9 to 1.1 N-m)

**MATERIAL**

Body	Gold plated beryllium copper
Coupling Nut	Passivated stainless steel
Body	Gold plated beryllium copper

NOTE: For mated pair APC-2.4 connectors on 2.4mm airlines.

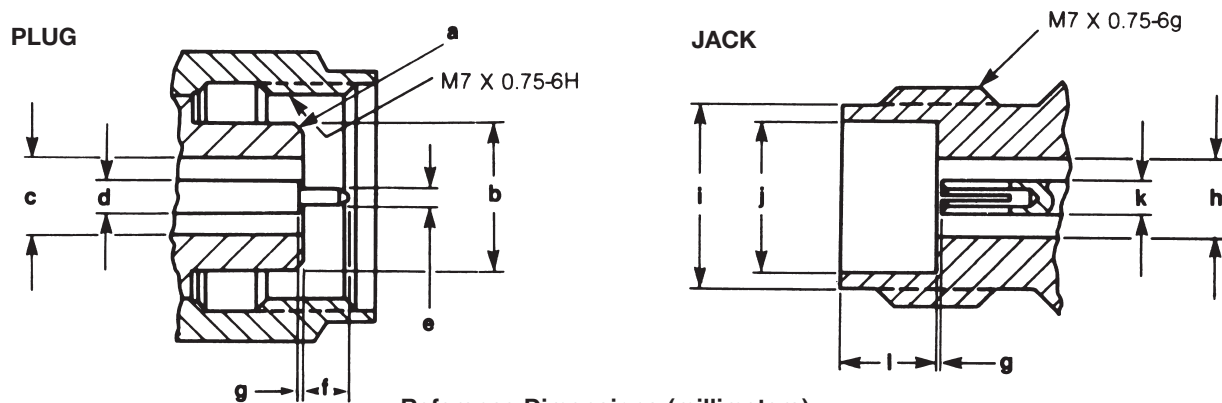

**Reference Dimensions (millimeters)**

<b>a</b> 0.25/0.36 x 45°	<b>e</b> ∅ 0.511 ±0.005	<b>i</b> ∅ 5.84 ±0.005
<b>b</b> ∅ 4.75 ±0.025	<b>f</b> ∅ 1.39 ±0.06	<b>j</b> ∅ 4.77 ±0.0025
<b>c</b> ∅ 2.400 ±0.005	<b>g</b> ∅ 0.000 ±0.053	<b>k</b> ∅ 1.042 ±0.0025
<b>d</b> ∅ 1.042 ±0.0025	<b>h</b> ∅ 2.400 ±0.005	<b>l</b> ∅ 3.05 ±0.05



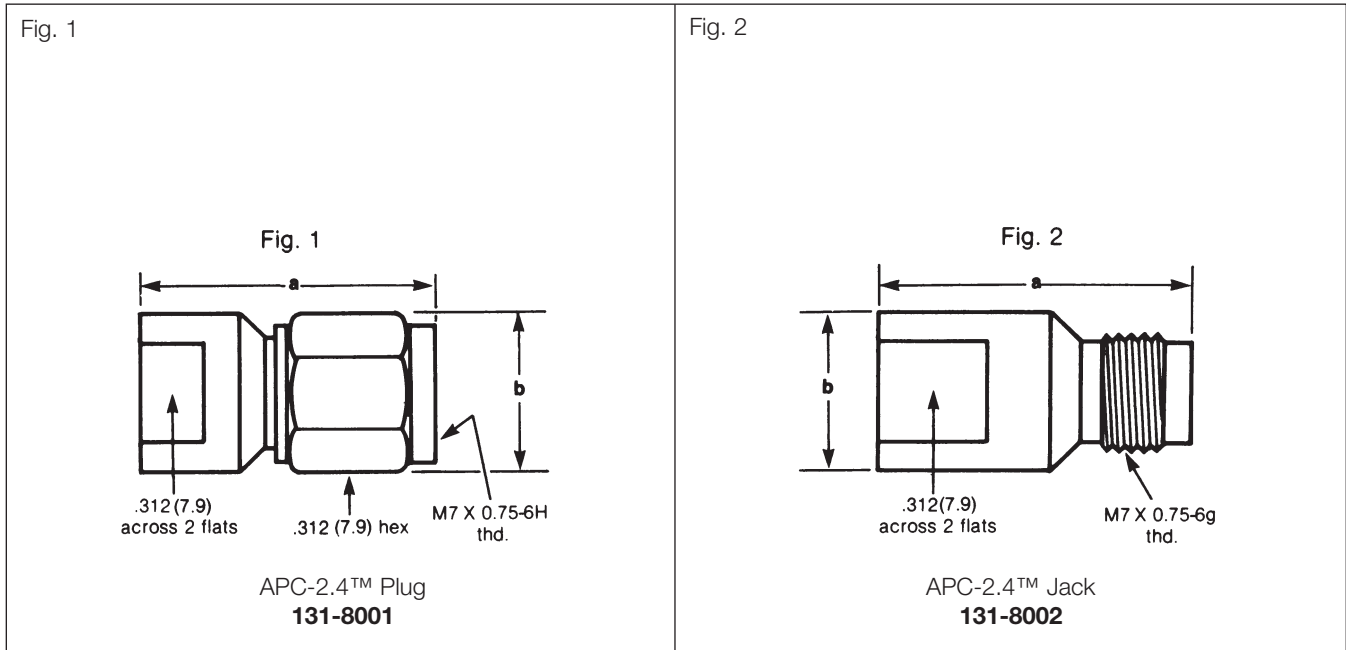

Description	Dimensions, Inches (mm)		CAI	Amphenol Number	Fig.
	a	b			
Plug	.665 (16.9)	.312 (7.9) hex	C65	<b>131-8001</b>	1
Jack	.700 (17.8)	.360 (9.1) dia.	C65	<b>131-8002</b>	2

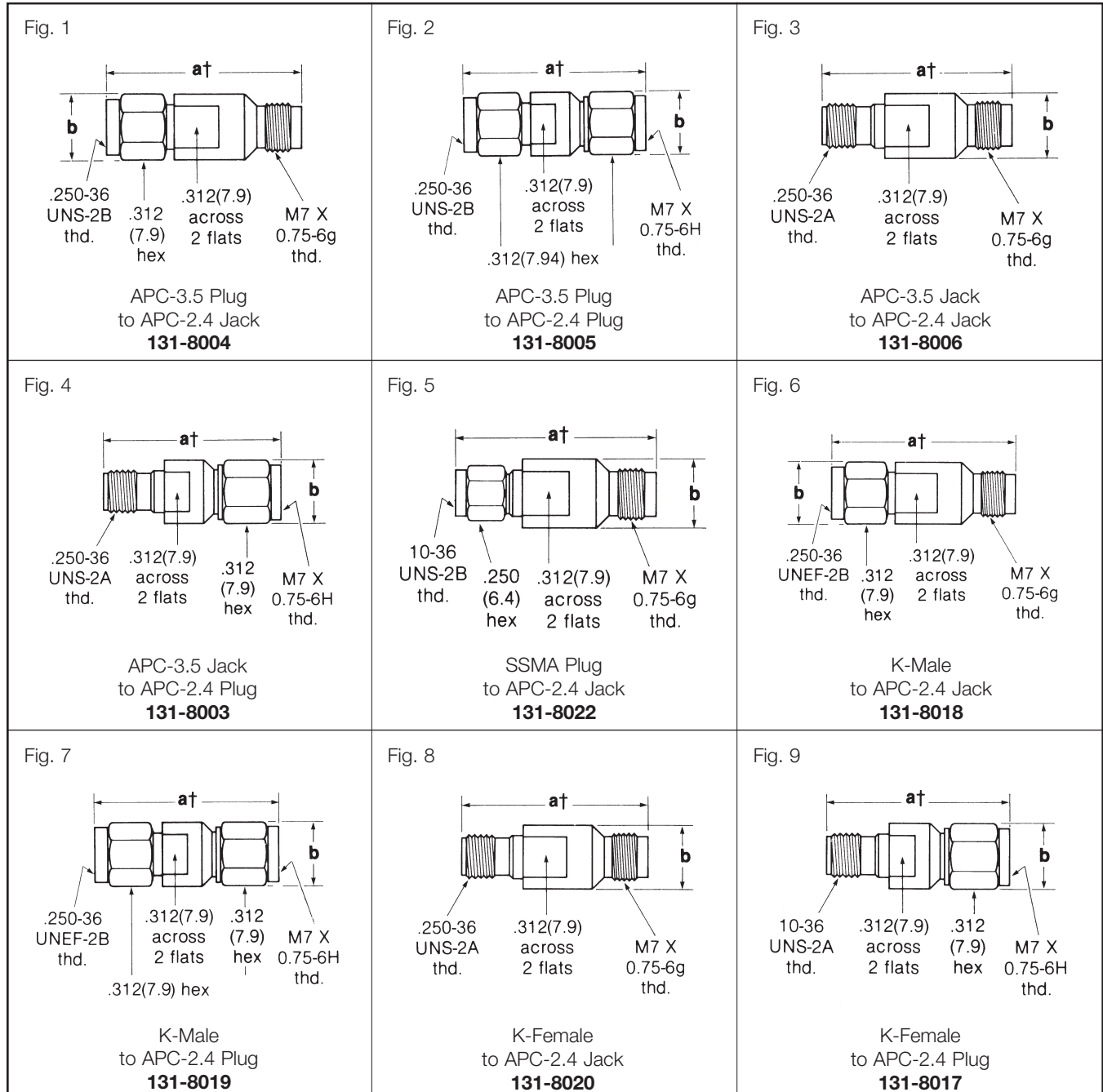

**PRECISION APC-2.4™ STRAIGHT ADAPTERS BETWEEN SERIES**

Adapter Ends		Dimensions inches (mm) b	Return Loss (minimum)	Amphenol Number	Fig.
APC-3.5 Plug	APC-2.4 Jack	.312 (7.9) hex	30 dB to 26.5 GHz/28 dB to 34 GHz	<a href="#">131-8004</a>	1
APC-3.5 Plug	APC-2.4 Plug	.312 (7.9) hex	30 dB to 26.5 GHz/28 dB to 34 GHz	<a href="#">131-8005</a>	2
APC-3.5 Jack	APC-2.4 Jack	.360 (9.14)	30 dB to 26.5 GHz/28 dB to 34 GHz	<a href="#">131-8006</a>	3
APC-3.5 Jack	APC-2.4 Plug	.312 (7.9) hex	30 dB to 26.5 GHz/28 dB to 34 GHz	<a href="#">131-8003</a>	4
SSMA Plug	APC-2.4 Jack	.360 (9.14)	29 dB to 18 GHz/26 dB to 24 GHz	<a href="#">131-8022</a>	5
K-Male	APC-2.4 Jack	.312 (7.9) hex	29 dB to 26.5 GHz/26 dB to 40 GHz	<a href="#">131-8018</a>	6
K-Male	APC-2.4 Plug	.312 (7.9) hex	29 dB to 26.5 GHz/26 dB to 40 GHz	<a href="#">131-8019</a>	7
K-Female	APC-2.4 Jack	.360 (9.14)	29 dB to 26.5 GHz/26 dB to 40 GHz	<a href="#">131-8020</a>	8
K-Female	APC-2.4 Plug	.312 (7.9) hex	29 dB to 26.5 GHz/26 dB to 40 GHz	<a href="#">131-8017</a>	9

† Envelope dimension a is a maximum of 1.5" (38.1mm) for all APC-2.4 adapters shown above. The length from reference plane to reference plane for each of these adapters is identical and equals .850" (21.6mm).

Amphenol® APC-3.5® connectors are a high performance, 50 ohm coaxial connector designed to exhibit low VSWR, low loss, and be resonance free to 34 GHz.

**Features/Benefits**

- Connectors are designed for use with 3.5mm rigid airline, .085 and .141 semi-rigid cable.
- Air dielectric mating face and thicker outer conductor shoulder.
- APC-3.5 design maintains mechanical and electrical integrity through repeated mating cycles.
- APC-3.5 will mate with SMA connectors.
- Provides VSWR performance typical of SMA mated pairs up to 18 GHz.

*Instructions for assembling APC-3.5 connectors to 3.5mm airline are given on page XX.*

**Specifications**

**ELECTRICAL**

	Test Requirement
Impedance	50 ohms
Frequency range	0-34 GHz
VSWR	Connectors on airline 1.01 + .004f (GHz)
Insertion loss (in dB)	.015 $\sqrt{f}$ (MHz)
RF Leakage	> 100 dB @ 26.5 GHz
Contact resistance	Inner: < 2.0 milliohms Outer: < 0.4 milliohms
Voltage rating:	500 Vrms
<u>Dielectric Withstanding</u> Voltage (max.):	1500 Vrms
<u>Max. power</u> (watts @ sea level)	2.5 kW / $\sqrt{f}$ (MHz) above 1 (MHz)

**ENVIRONMENTAL**

Mating	1/4-36 threaded coupling
--------	--------------------------

**MECHANICAL**

Body and Coupling Nut	Gold plated beryllium copper
Center Contacts	Gold plated beryllium copper

**MATERIAL**

Temperature range	-65°C to + 85°C
Humidity	20 to 80% RH
Pressure	590 to 780 mm Hg

**PLUG**

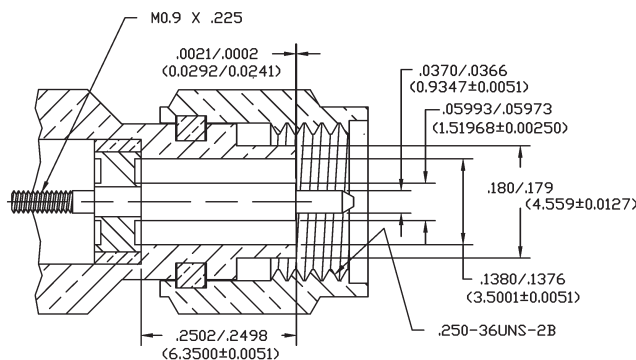

**JACK**

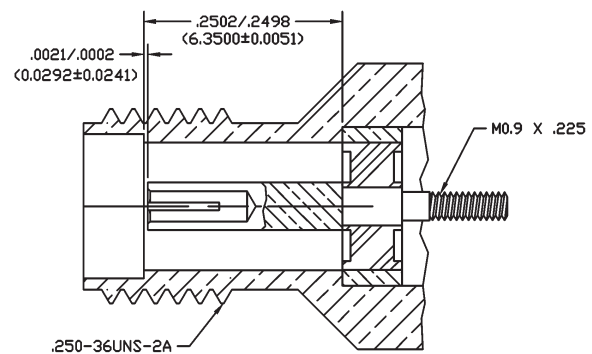

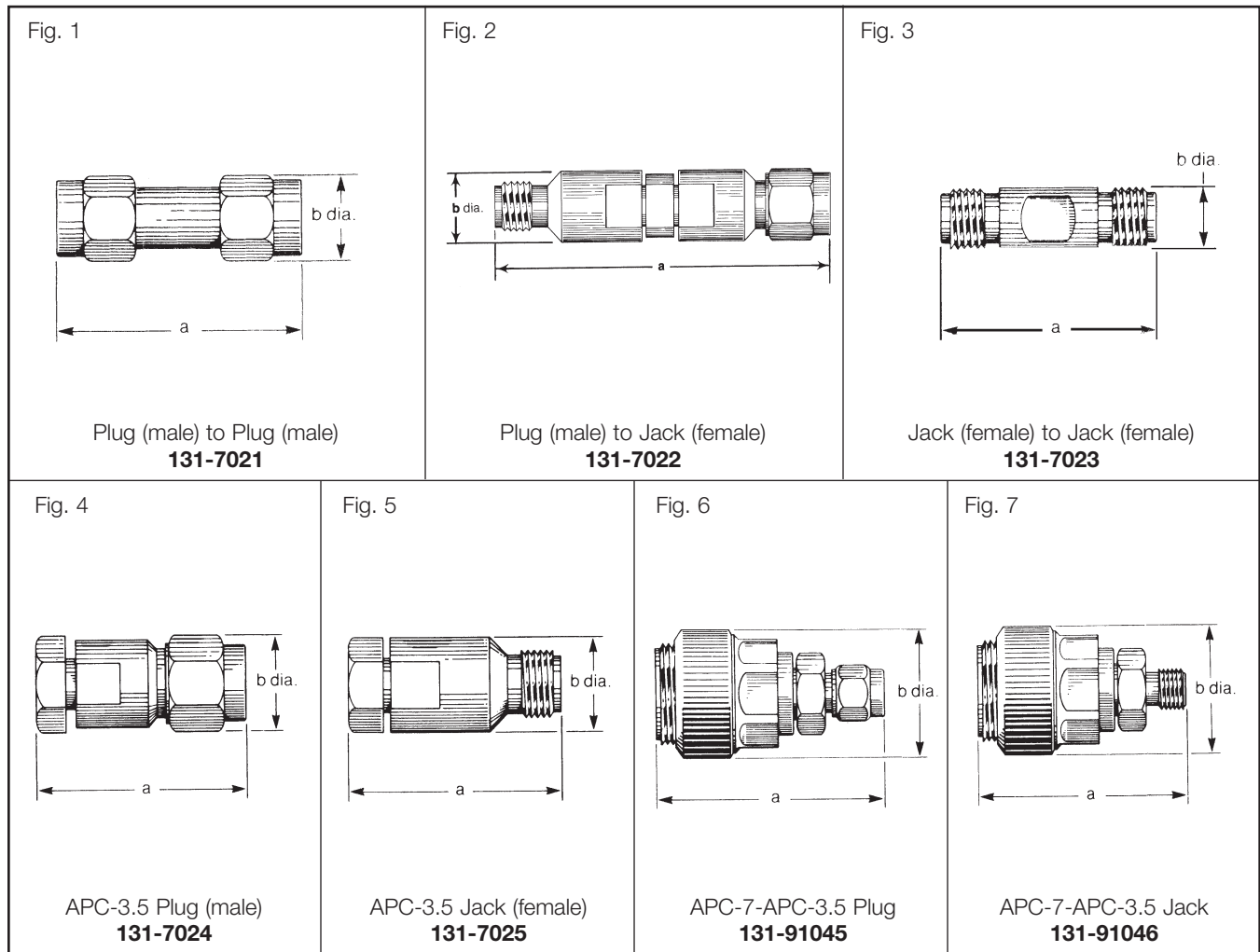

**ADAPTERS WITHIN SERIES**

Description	Dimensions, Inches (mm)		Amphenol Number	Fig.
	a	b		
Plug (male) — Plug (male)	1.78 (45.3)	.360 (9.1)	<a href="#">131-7021</a>	1
Plug (male) — Jack (female)	1.75 (44.5)	.360 (9.1)	<a href="#">131-7022</a>	2
Jack (female) — Jack (female)	1.71 (43.5)	.360 (9.1)	<a href="#">131-7023</a>	3

**SHORT CIRCUIT TERMINATION**

Description	Dimensions, Inches (mm)		CAI	Amphenol Number	Fig.
	a	b			
APC-3.5 Plug (male)	.902 (23.0)	.360 (9.1)	C66	<a href="#">131-7024</a>	4
APC-3.5 Jack (female)	.862 (21.9)	.360 (9.1)	C66	<a href="#">131-7025</a>	5

**ADAPTERS**

Description	Dimensions, Inches (mm)		Amphenol Number	Fig.
	a	b		
APC-7-APC-3.5 Plug	1.567 (39.8)	.875 (22.2)	<a href="#">131-91045</a>	6
APC-7-APC-3.5 Jack	1.483 (37.7)	.875 (22.2)	<a href="#">131-91046</a>	7

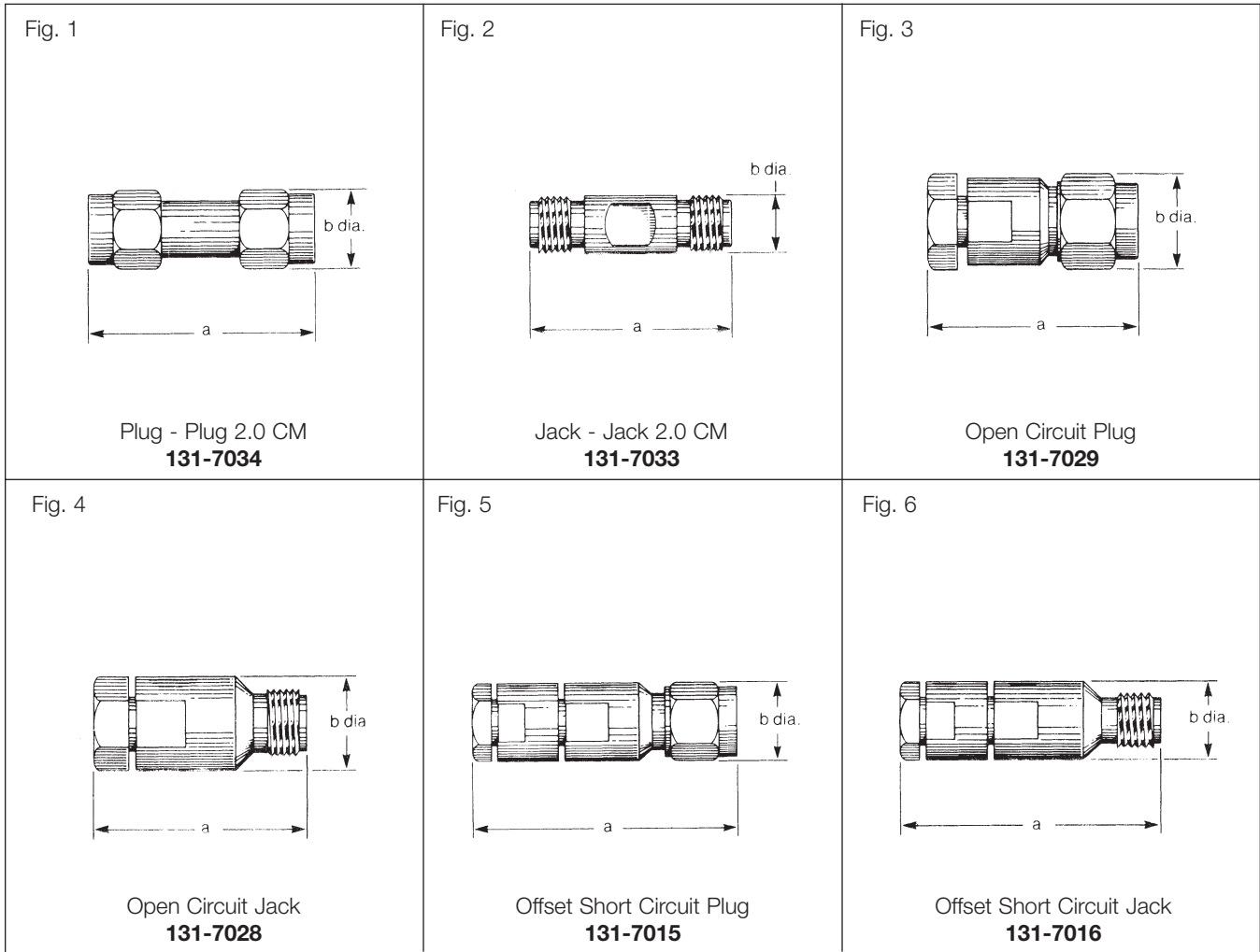

**AIRLINE ASSEMBLIES**

Description	Dimensions, Inches (mm)		Amphenol Number	Fig.
	a	b		
Plug - Plug 2.0 CM	1.07 (27.3)	.360 (9.1)	<b>131-7034</b>	1
Jack - Jack 2.0 CM	.939 (23.9)	.250 (6.4)	<b>131-7033</b>	2

**OPEN CIRCUIT TERMINATION**

Description	Dimensions, Inches (mm)		CAI	Amphenol Number	Fig.
	a	b			
Plug	.902 (23.0)	.360 (9.1)	C66	<b>131-7029</b>	3
Jack	.862 (21.9)	.360 (9.1)	C66	<b>131-7028</b>	4

**OFFSET SHORT CIRCUIT TERMINATION**

Description	Dimensions, Inches (mm)		CAI	Amphenol Number	Fig.
	a	b			
Plug (2-4 GHz)	1.801 (45.7)	.360 (9.1)	C66	<b>131-7015-1</b>	5
Plug (4-8 GHz)	1.306 (33.2)	.360 (9.1)	C66	<b>131-7015-2</b>	5
Plug (8-12.4 GHz)	1.206 (30.6)	.360 (9.1)	C66	<b>131-7015-3</b>	5
Plug (12.4-18 GHz)	1.206 (30.6)	.360 (9.1)	C66	<b>131-7015-4</b>	5
Jack (2-4 GHz)	1.766 (44.9)	.360 (9.1)	C66	<b>131-7016-1</b>	6
Jack (4-8 GHz)	1.271 (32.3)	.360 (9.1)	C66	<b>131-7016-2</b>	6
Jack (8-12.4 GHz)	1.171 (29.7)	.360 (9.1)	C66	<b>131-7016-3</b>	6
Jack (12.4-18 GHz)	1.171 (29.7)	.360 (9.1)	C66	<b>131-7016-4</b>	6

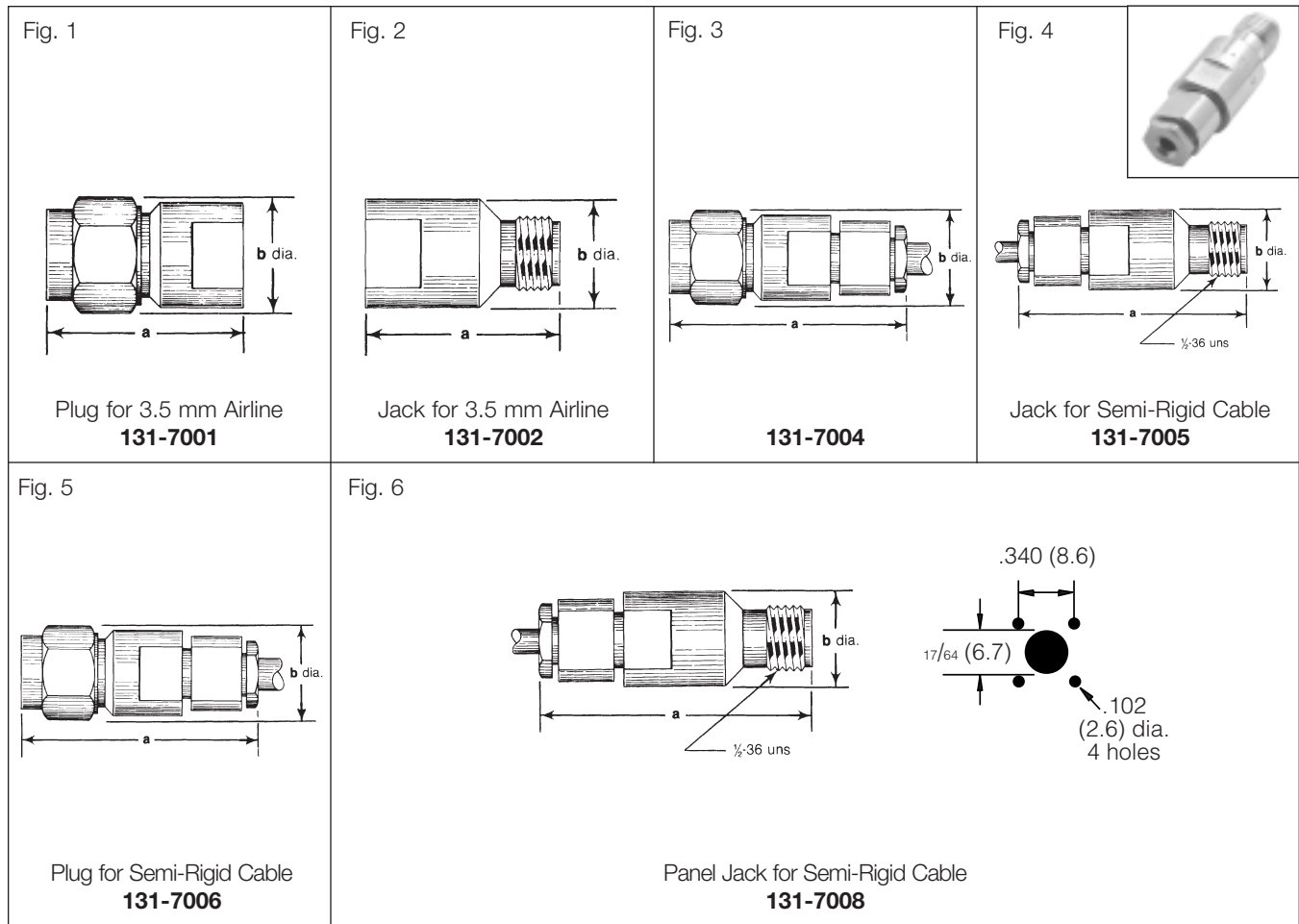

**PLUGS • JACKS • PANEL JACKS**

Cable	Inner Attachment	Cable Termination	Dimensions Inches (mm)			CAI	Construction Notes	Amphenol Number	Fig.
			a	b	c				
3.5mm Airline	Plug (male)	Screw Thds.	.799 (20.3)	.312 (7.9)	—	C66	—	<b>131-7001</b>	1
	Jack (female)	Screw Thds.	.761 (19.3)	.321 (9.1)	—	C66	—	<b>131-7002</b>	2
Rg-405 (.085" Dia. Metal) Jacketed, Semi-Rigid Cable	Plug (male)	Solder	1.104 (28.0)	.312 (7.9)	—	C66	—	<b>131-7004</b>	3
	Jack (female)	Solder	1.069 (27.2)	.360 (9.1)	—	C66	—	<b>131-7005</b>	4
	Panel Jack	Solder	1.069 (27.2)	.500 (12.7)	.335/.315 (8.3 ± 0.3)	C66	Mtg. Hole Z/max. panel thick .085 (2.2)	<b>131-7008</b>	6
Rg-402 (.141" Dia. Metal) Jacketed, Semi-Rigid Cable	Plug (male)	Solder	1.104 (28.0)	.312 (7.9)	—	C66	—	<b>131-7006</b>	5
	Jack (female)	Solder	1.069 (27.2)	.360 (9.1)	—	C66	—	<b>131-7007</b>	—

### APC-7™ Coaxial Connectors

Amphenol® APC-7™ connectors are precision devices which provide long life and accurate, repeatable performance in test and instrumentation applications.

#### Features/Benefits

- Primarily for use with rigid 7mm airline (7mm = the inner diameter of the airline outer conductor).
- Designs are also available for use with .250 semi-rigid cable, and RG-214/U flexible cable.
- Coupling mechanism is sexless thus permitting any two APC-7 connectors to be mated.
- A certified test report of VSWR will be provided when a mated pair of APC-7 connectors is ordered (131 - 91050).

*NOTE: A fluted nut design is provided as an option to APC-7 connectors. To order the fluted nut configuration, simply delete the "9" from the core part number; for example:*

131-91051 Hex Knurled Nut  
131-1051 Fluted Nut

### Specifications

#### ELECTRICAL

	Test Requirement
Impedance	50 ohms
Frequency range	0-18 GHz
VSWR	Connectors on airline $1.003 + .002f$ (GHz)
Insertion loss (in dB)	$< 7 \times 10^{-3} \sqrt{f}$ (MHz) example: 0.028 dB at 16.0 GHz)
RF Leakage	< signal inside coaxial line by ratio > 120 dB
Electrical length	.693 inches (1.76 cm)
Contact resistance	Inner: < 1.0 milliohms Outer: < 0.1 milliohms
Voltage rating:	1000 Vrms
Dielectric Withstanding Voltage (max.):	2500 Vrms
Max. power (watts @ sea level)	Above 1 MHz = $10kW / \sqrt{f}$ (MHz) up to 1 MHz = 10kW

#### ENVIRONMENTAL

Mating	Sexless, coplanar by means of threaded ring housed within coupling nut
Life	> 5000 connect/disconnect operations

#### MECHANICAL

Coupling mechanism	Stainless steel
Body	Gold plated beryllium copper
Center Contacts	Gold plated beryllium copper
Dielectric support	Air-polyphenylene oxide composite
Clamping components	Nickel plated brass
Crimp ferrule	Nickel plated copper

#### MATERIAL

Temperature range	Storage: -65°C to + 85°C Operating: -13°C to + 33°C
Humidity	20 to 80% RH
Pressure	590 to 780 mm Hg

#### PLUG

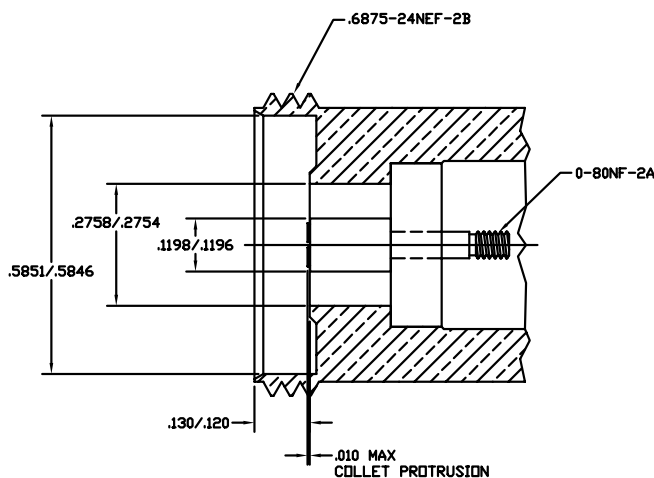

#### JACK

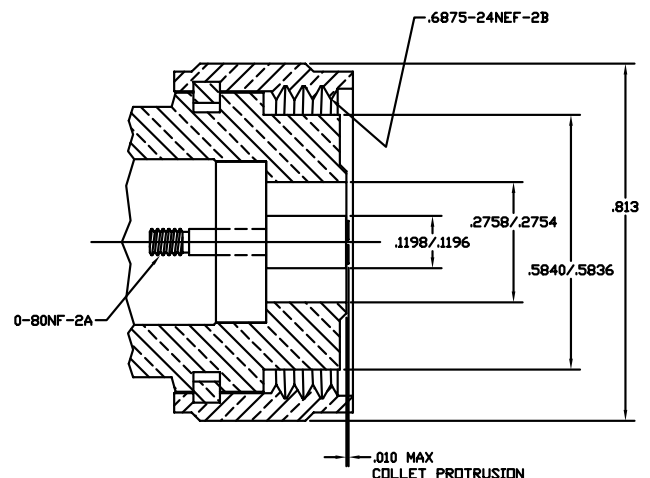

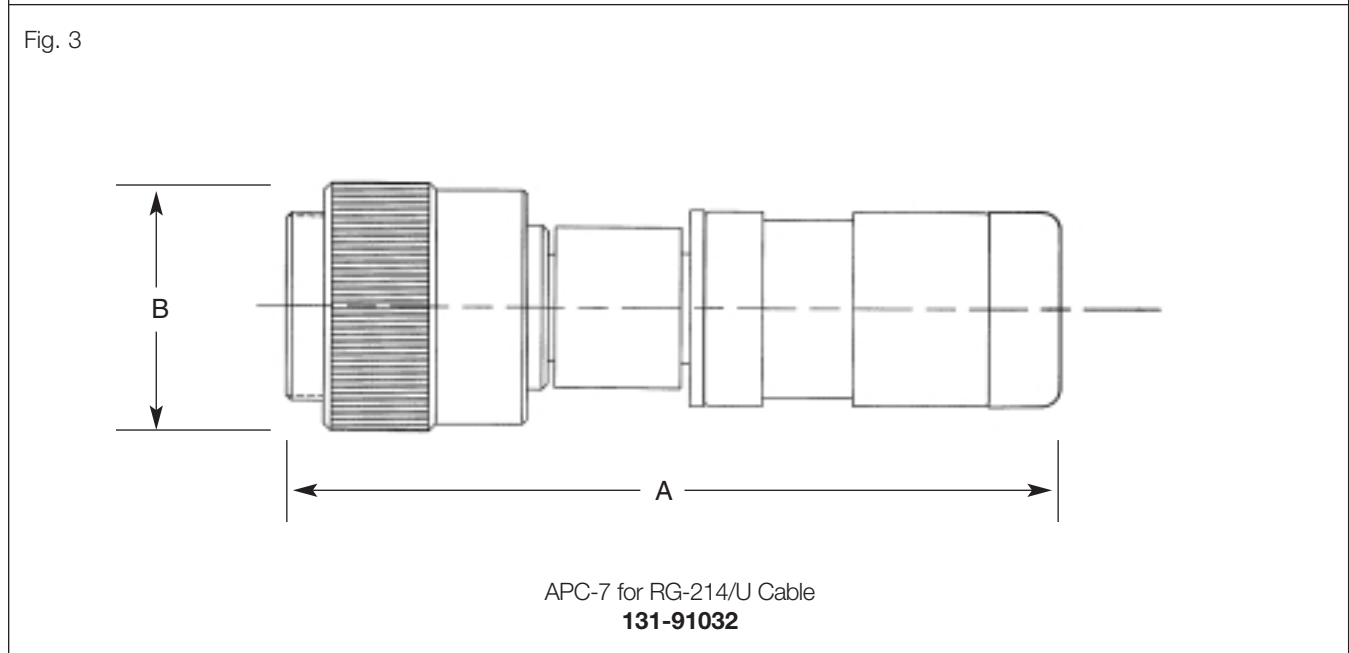
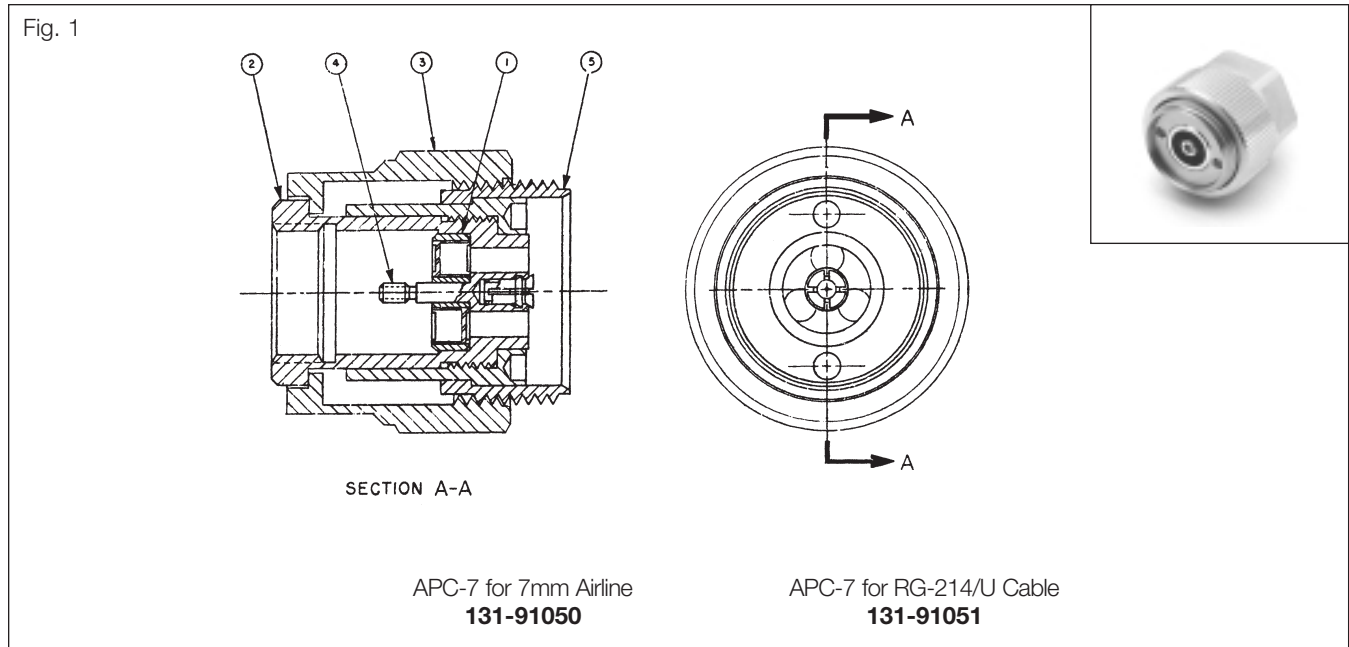

**APC-7™ COAXIAL**





The electrical length of the APC-7 connector is 1.76 cm

For Use With	Dimensions, Inches (mm)		Connector Affixment	Max. VSWR for Mated Pair	CAI	Amphenol Number	Fig.
	a □	b					
7mm Airline	.922 (23.4)	.865 (22.0)	Threaded Airline	1.003 + .002F (GHz)	C67	<b>131-91050</b> ■	1
	.922 (23.4)	.865 (22.0)	Threaded Airline	1.003 + .002F (GHz)	C67	<b>131-91051</b>	2
RG-214/U Cable	2.594 (65.9)	.865 (22.0)	Braided Clamp	1.15 + 12.4 (GHz)	C67	<b>131-91032</b>	3

Part numbers listed are for one (1) connector except #131-91050 ■

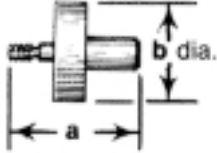
□ Overall length with retainer in extended position

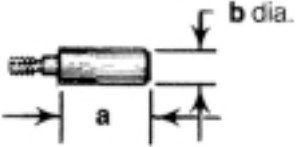
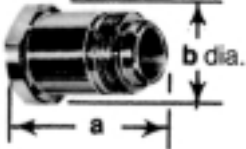
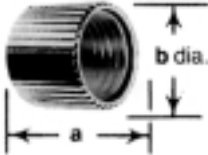
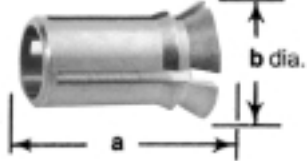
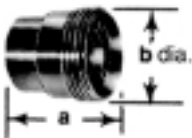

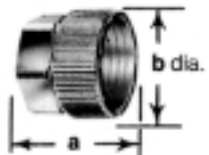
<p>Fig. 1</p>  <p>Bead Contact Sub-Assembly <b>131-1052</b></p>	<p>Fig. 2</p>  <p>Bead <b>131-1053</b></p>	<p>Fig. 3</p>  <p>Contact Sub-Assembly <b>131-1054</b></p>
<p>Fig. 4</p>  <p>Body <b>131-122</b></p>	<p>Fig. 5</p>  <p>Optional Fluted Nut <b>131-126</b></p>	<p>Fig. 6</p>  <p>Collet <b>131-129</b></p>
<p>Fig. 7</p>  <p>Retainer Sub-Assembly <b>131-131</b></p>	<p>Fig. 8</p>  <p>Nut, Body &amp; Assembly Sub-Assembly <b>131-91057</b></p>	<p>Fig. 9</p>  <p>Coupling Nut Standard Hex. <b>131-926</b></p>

**COMPONENTS AND SUB-ASSEMBLIES**

Description	Dimensions, Inches (mm)		Amphenol Number	Fig.
	a	b		
Bead-contact sub-assembly	.461 (11.7)	.370 (9.4)	<a href="#">131-1052</a>	1
Bead	.116 (3.0)	.370 (9.4)	<a href="#">131-1053</a>	2
Contact (Collet & Collet holder) sub-assembly	.183 (4.6)	.120 (3.0)	<a href="#">131-1054</a>	3
Body for 7mm Airline	.800 (20.3)	.576 (14.6)	<a href="#">131-122</a>	4
Optional Fluted Coupling Nut	.702 (17.8)	.812 (20.6)	<a href="#">131-126</a>	5
Collet	.149 (3.8)	.103 (2.6)	<a href="#">131-129</a>	6
Retainer sub-assembly	.676 (17.2)	.687 (17.5)	<a href="#">131-131</a>	7
Coupling Nut — Retainer body sub-assembly for 7mm Airline (131-91051 less bead-contact S/A)	.921 (23.4)	.865 (22.0)	<a href="#">131-91057</a>	8
Standard Hex coupling nut	.702 (17.8)	.865 (22.0)	<a href="#">131-926</a>	9

**APC-N Coaxial Connectors**

Amphenol® APC-N connectors can be used interchangeably with the APC-7 on rigid air line or equipment and mates with all other Type N connectors.

VSWR for a mated pair of APC-N connectors is 1.06 through 12.4 GHz and 1.08 through 18 GHz.

**Specifications**

**ELECTRICAL**

	Test Requirement
Impedance	50 ohms ± 0.1 Ohms
Frequency range	0-18 GHz
VSWR	Connectors on airline 1.08 max. to 18 (GHz)
Insertion loss (in dB)	$< 3 \times 10^{-2} \sqrt{f} \text{ (GHz)}$
RF Leakage	< signal inside coaxial line by ratio > 90 dB
Contact resistance	Inner: < 10 milliohms Outer: < 1.1 milliohms
Voltage rating:	1000 Vrms
Dielectric Withstanding Voltage (max.):	2500 Vrms
Max. power (watts @ sea level)	Above 1 MHz = 10kW/ $\sqrt{f} \text{ (MHz)}$ up to 1 MHz = 10kW

**MECHANICAL**

Mating	<sup>11</sup> / <sub>16</sub> -24 threaded coupling. Mating dimensions are MIL-C-39012 Class II nominal with tighter tolerances. The APC-N mates with all existing Type N connectors including MIL-C-71
--------	---

**MATERIAL**

Body & coupling nut	Stainless steel
Center Contacts	Gold plated beryllium copper
Bead Assembly	Air-polyphenelene oxide composite
Clamping components	Nickel plated brass
Crimp ferrule	Nickel plated copper

**ENVIRONMENTAL**

Temperature range	Storage: -55°C to + 70°C Operating: -13°C to + 33°C
Humidity	20 to 80% RH
Pressure	590 to 780 mm Hg

\* These characteristics are typical and may not apply to all connectors.

**VSWR of a mated pair of APC-N connectors**

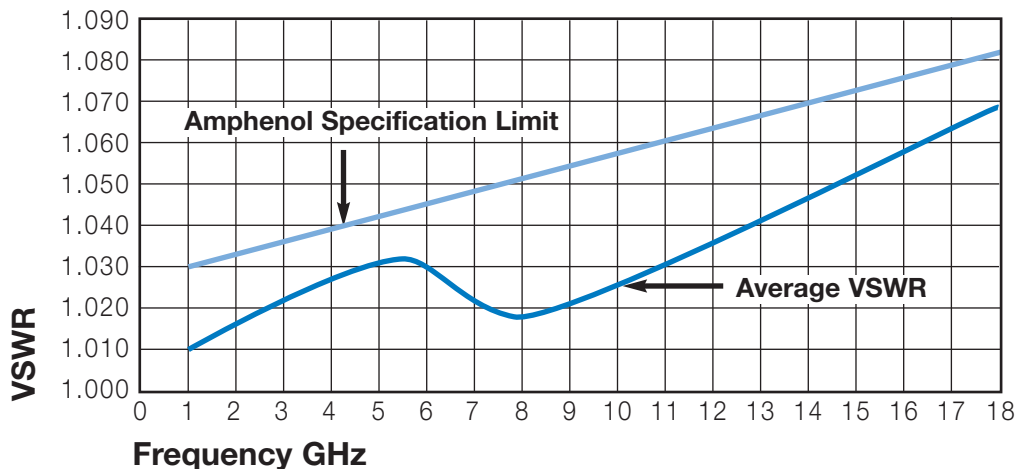

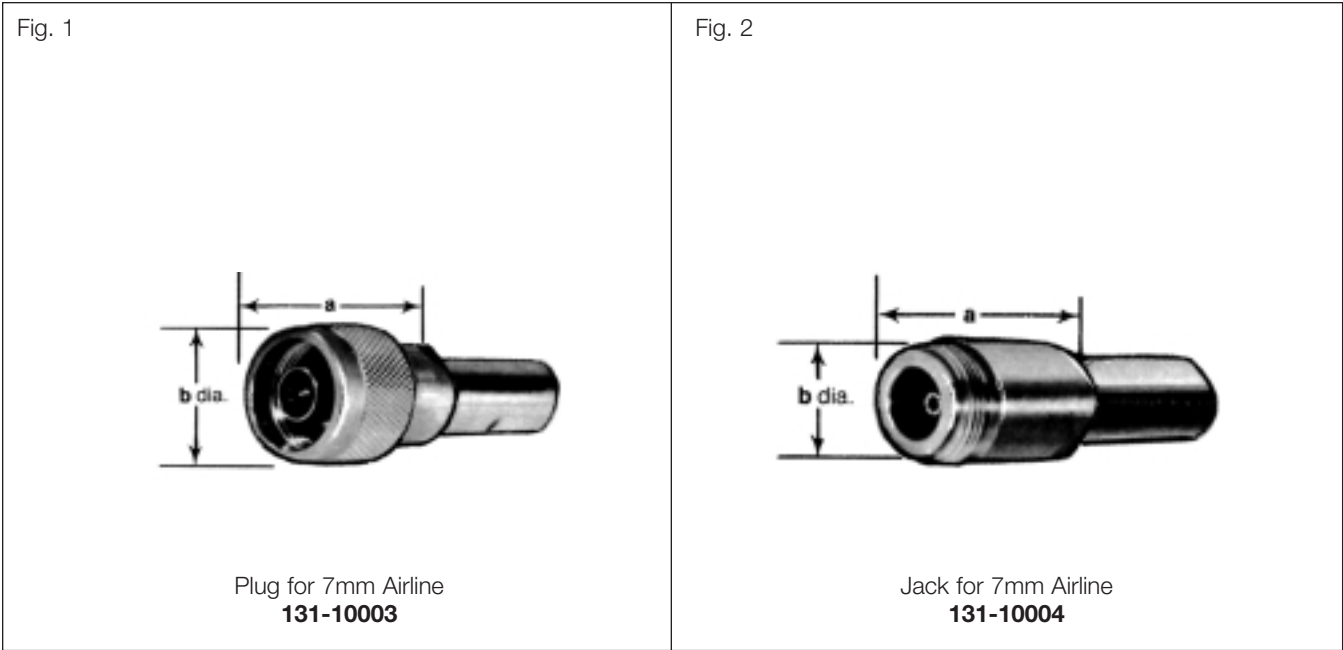

**PLUG**

For Use With	Dimensions, Inches (mm)		Connector Affixment	Max. VSWR for Mated Pair	CAI	Amphenol Number	Fig.
	a	b					
7mm Airline	1.141 (29.0)	.813 (20.6)	Threaded Airline	1.08 + 18 (GHz)	C67	<a href="#">131-10003</a>	1

**JACK**

For Use With	Dimensions, Inches (mm)		Connector Affixment	Max. VSWR for Mated Pair	CAI	Amphenol Number	Fig.
	a	b					
7mm Airline	1.099 (27.9)	.620 (15.7)	Threaded Airline	1.08 + 18 (GHz)	C67	<a href="#">131-10004</a>	2



# Contents

Overview .....	100
1.6 / 5.6 .....	101-104
BNC (50 ohm) .....	105-122
BNC (75 ohm) .....	124-134
BNC/TNC for LMR .....	135-138
TNC .....	139-148
Reverse Polarity .....	149-158
Tools .....	159



Amphenol's family of miniature connectors includes **1.6/5.6**, **BNC** and **TNC**. These designs are all encompassing and include: "bayonet coupling", "threaded coupling", and push/pull mating styles. Additionally, the miniature connector line features many configurations and considerable varieties of coaxial cable. The large variety of product offerings provides the design engineer flexibility to choose the right connector for the project.

**TNC** connectors are miniature 50 ohm semi-precision units which operate from DC to 11 GHz. These connectors are weatherproof and contain a threaded coupling mechanism. These features are ideal for outdoor applications as well as where extreme vibration is a factor.



The **1.6/5.6** coaxial connectors are miniature 75 ohm units with threaded coupling mechanisms. The relative compact design of the 1.6/5.6 allows for dense packaging, making the connector ideally suited for applications where space limitations are a factor.

Amphenol's family of **BNC** coaxial connectors are available in both 50 and 75 ohm interconnect systems, providing RF performance up to 11 GHz and low reflection DC - 4 GHz. They are lightweight miniature units designed to accommodate a large variety of RG cables. These bayonet locking connectors are available in crimp-crimp, clamp-solder, SURETWIST® and field serviceable termination styles.



### Description

The 1.6/5.6 series is a European design with two coupling versions: Threaded provides positive mating, Push-pull allows quick installation. Amphenol 1.6/5.6 coaxial connectors are miniature 75 ohm units operating from 0-1GHz.

The compact design of the 1.6/5.6 permits dense connector packing making these connectors ideally suited to applications where space limitation is a factor.

This series complies with DIN 47295, DIN 41626, DIN 47297, NFC 93-569, NFC 93-570, IEC 169-13, and the CECC 22230 standards.

### Features/Benefits

- Meets IEC 169-13, DIN 47295 and NFC 93-570 international specifications designed for SMT.
- Plugs and bulkhead jacks are available in crimp-crimp termination versions to ensure high reliability in connector assembly and a lower cost installation method.
- Threaded coupling designed for quick connect/disconnect allows safe coupling.

### Application

- Base Stations
- Cable Assemblies
- Computer / LAN
- Routers
- Switching Equipment
- Telecom
- Wireless

### 1.6/5.6

Specifications	102
Plugs & Receptacles	103

# 1.6/5.6 Specifications

### ELECTRICAL

Impedance	75 ohms
Frequency range	0-1GHz
Voltage rating	330 volts peak
Other	Contact resistance: Center contact 4 milliohm Outer contact 2 milliohm Insulation resistance: 10000 megohms

### ENVIRONMENTAL

Temperature range	- 40°C to +155°C
Connector Durability	500 matings

### MECHANICAL

Mating	M9 x 0.5 threaded coupling
Cable affixment (braid or jacket)	Hex crimp
Cable affixment (center conductor)	Crimp or solder
Captivated contacts	All crimps

### MATERIAL

Contacts	Male: Brass Female: (center and outer) Beryllium copper. Gold plated
Other metal parts	Brass, nickel plated
Insulators	Teflon
Crimp ferrule	Copper

NOTE: These characteristics are typical and may not apply to all connectors.

### PLUG

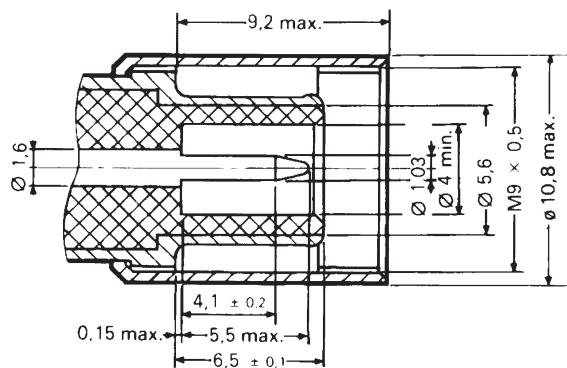

### JACK

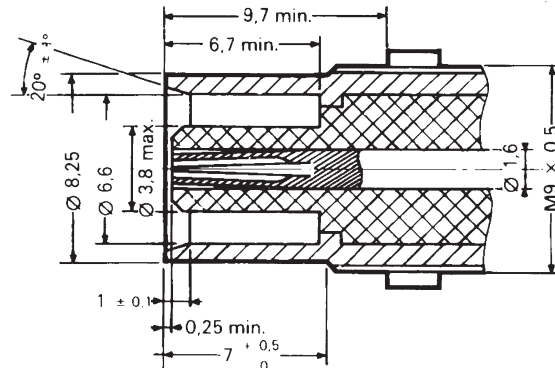



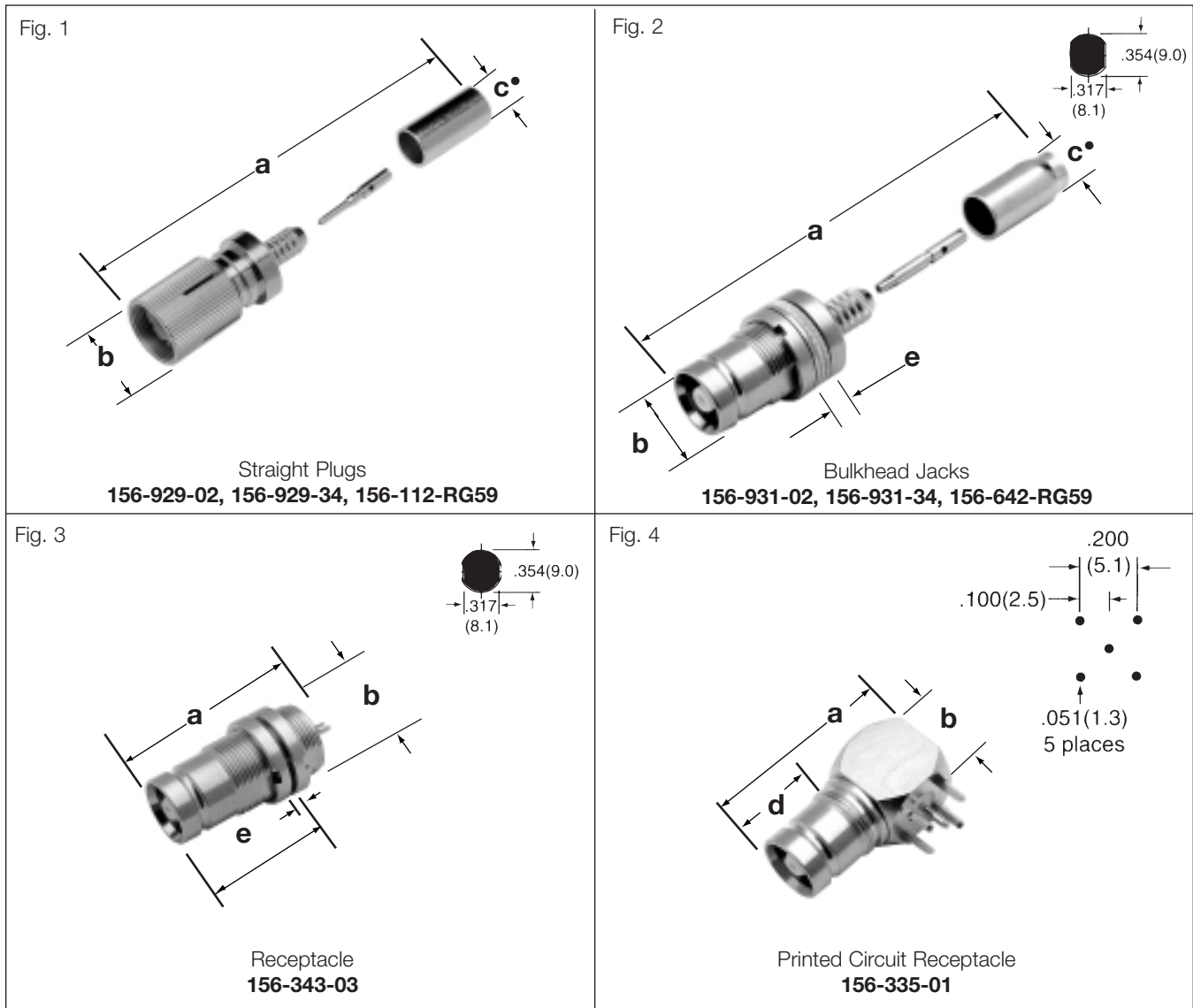

1.6/5.6 PLUGS, BULKHEAD JACKS, RECEPTACLES

Connector Description	Cable	Cable Attachment		Dimensions, inches (millimeters)					Amphenol Number	Fig.	
		Outer	Inner	a	b	c •	d	e			
Plug	L910/34 BT3002	Crimp	Crimp	1.18 ■ (30.0)	.425 (10.8)	.161 (4.1)	—	—	<b>156-929-34</b>	1	
	L910/16	Crimp	Crimp	1.18 ■ (30.0)	.425 (10.8)	.205 (5.2)	—	—		<b>156-929-02</b>	1
	RG59	Crimp	Crimp	.984 (25.0)	.433 (11.0)	.220 (5.6)	—	—		<b>156-112-RG59</b>	1
Bulkhead Jack	L910/34 BT3002	Crimp	Crimp	1.26 ■ (32.0)	.425 (10.8)	.161 (4.1)	.543 (13.8)	.047 (1.2)	<b>156-931-34</b>	2	
	L910/16	Crimp	Crimp	1.26 ■ (32.0)	.425 (10.8)	.205 (5.2)	.543 (13.8)	.047 (1.2)		<b>156-931-02</b>	2
	RG59	Crimp	Crimp	1.00 (25.5)	.425 (10.8)	.220 (5.6)	—	—		<b>156-642-RG59</b>	2
Receptacle	Front Mount or Rear Mount	Solder Cup		.906 (23.0)	.425 (10.8)	—	.630 (16.0)	.138 (3.5)	<b>156-343-03</b>	3	
Printed Circuit Receptacle	4 legs & terminal .118 (3.0) long x .039 (1.0) diameter / .039 (1.0) stand off pads	Blunt Post		.827 (21.0)	.433 (11.0)	—	.433 (11.0)	—	<b>156-335-01</b>	4	

• accommodates cable diameter ■ includes outer ferrule



**Description**

Developed in the late 1940's, the BNC is a miniature version of the Type C. BNC stands for Bayonet Neill Concelman and is available in 50 Ohm and 75 Ohm impedance versions.

The BNC product line is a miniature quick connect / disconnect RF connector. It features two bayonet lugs on the female connector; mating is achieved with only a quarter turn of the coupling nut.

Primary Applications - Ideally suited for cable termination for miniature to subminiature coaxial cable (RG-58, 59, to RG-179, RG-316, etc.)

**Features/Benefits**

- Bayonet coupling mechanism provides quick mating and unmating.
- 50 and 75 ohm impedance designs allow customers to match impedance to system requirements.
- 50 and 75 ohm connectors are intermateable to ensure nondestructive mating.
- Three grades of connectors are available for military, industrial and commercial applications.

**Applications**

- Antennas
- Automotive (GPS)
- Base Stations
- Broadcast (75 ohm)
- Cable Assemblies
- Cable Modems
- Components
- Computers/LANs
- Instrumentation
- Network Analyzers
- Oscilloscopes
- Medical Equipment
- Mil-Aerospace
- Networks
- Radios
- Satcom
- Surge Protection
- Telecom



**50 ohm  
BNC Cable Connectors**

Specifications	107
Cable Plugs	108-109
Cable Jacks	110
Receptacles	114-115
PCB Receptacles	116-118
Adapters	119-121
Caps & Accessories	122

**75 ohm**

Specifications	124
High Performance Plugs	125-126
Jacks & Receptacles	127
PCB Receptacles	128-132
Adapters	133-134



## Description

Amphenol 50 ohm BNC connectors are miniature, lightweight units designed to operate up to 11 GHz and typically yield low reflection through 4 GHz. Designed to accommodate a large variety of RG and industry standard cables, BNC connectors are available in crimp-crimp, clamp-solder, SURETWIST®, and field serviceable termination styles. A full line of printed circuit board receptacles, bulkhead receptacles, resistor terminations, and other accessories complement the product offering.

## Features/Benefits

Amphenol manufactures a full line of BNC connectors to meet all users' needs. Parts which are listed with the appropriate M39012 number in the catalog are **Military Grade** connectors produced in accordance with and actively qualified to the military specification MIL-C-39012. Connectors not listed with the M39012 number constitute the **Industrial Grade** product offering. These connectors provide comparable performance and generally feature nickel plated brass bodies, Teflon insulators, and either gold or silver plated center contacts. Amphenol's **Commercial Grade** connector offering carries the part number designation "RFX" for easy recognition. These low cost connectors typically utilize diecast and molded components. While



performance will not be equal to the Industrial or Military grade products, these connectors are ideal for use on a variety of commercial applications.

Amphenol's 50 ohm BNC connectors (where indicated) are recognized under the Component Program of Underwriter's Laboratories, Inc. They are ideal for use with medical equipment and test instrumentation where safety cannot be compromised.

## Applications

- Computers/LANs
- Test and Measurement
- Medical Equipment
- Telecommunications
- Wireless/Networks

## 50 ohm

BNC 50 ohm Connectors	106
Plugs and Jacks	108-113
Adapters	119
PCB Connectors	120-121

## ELECTRICAL

Impedance	50 ohms nominal ■
Frequency range	0-4 GHz w/low reflection
Voltage rating	500 volts peak
Dielectric withstanding voltage	1,500 volts rms.
VSWR	M39012 straight connectors: 1.3 max. 0-4 GHz M39012 right angle: 1.35 max. 0-4 GHz
Other (MIL-C-39012 cable connectors)	Contact resistance: center contact 1.5 milliohm outer contact 0.2 milliohm Braid to body 0.1 milliohm RF leakage: - 55 dB minimum at 3 GHz Insertion loss: 0.2 dB maximum at 3 GHz Insulation resistance: 5000 megohms (min.)

## MECHANICAL

Mating	2-stud bayonet coupling per M39012
Cable affixment (braid or jacket)	All crimps: hex braid crimp. Clamps: screw-thread nut and braid clamp.
Cable affixment (center conductor)	Crimps: crimp or solder All others: solder only
Captivated contact	All crimps Others: where specified.
Cable retention	Crimps: 20-100 lbs. All others: 30-70 lbs.

## MATERIAL

Center contacts	Male: brass Female: Beryllium copper or phosphor bronze. Silver or gold plated
Other metal parts	Brass, Nickel finish except M39012 silver.
Insulators	TFE; copolymer of styrene, glass-TFE (hermetically sealed)
Clamp gaskets	Synthetic rubber, Silicone rubber
Crimp ferrule	Copper / Brass

## ENVIRONMENTAL

Temperature range	TFE insulators: - 65°C to + 165°C Copolymer of Styrene: - 55°C to + 85°C
Weatherproof	Clamps with clamp gaskets. Crimps with heat-shrink tubing.
Hermetic seals	Pass helium leak test of 2 X 10 <sup>-8</sup> cc/sec
Shock	MIL-Std. 202 method 202
Vibration	MIL-Std. 202 method 204 (test cond. D)
Moisture resistance	MIL-Std. 202 method 106
Corrosion	MIL-Std. 202 method 101 (test cond. B)
Temperature cycling	MIL-Std. 202 method 102 (test cond. D)
Altitude	MIL-Std. 202 method 105 (test cond. C)

## MILITARY SPECIFICATIONS

MIL-C-39012	Where applicable
-------------	------------------

NOTE: These characteristics are typical and may not apply to all connectors.

■ Also see 75 ohm BNC connectors in the following section

## PLUG

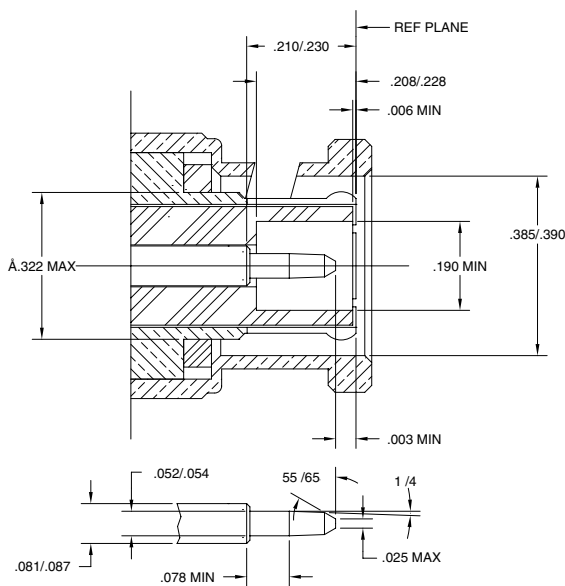

## JACK

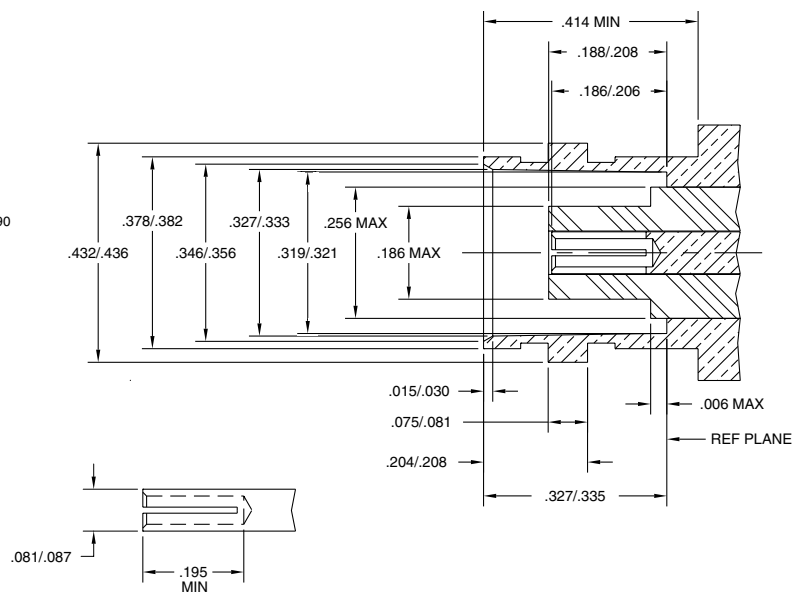

# BNC 50 ohm 3-Piece Cable Crimp Plugs

**Fig. 1**

BNC 3-Piece Crimp Plugs

36650-1003	68175-5RFX	31-320-1006	31-326	31-5557-RFX†
36650-3RFX	31-242	31-320-RFX	31-326-RFX	31-5558-RFX
36875	31-242-RFX	31-321	31-4320	31-5560-RFX†
68175-1003	31-315	31-321-1000	31-4321	31-5559-RFX
68175-1005	31-315-1005	31-321-RFX	31-4411	31-5559-1RFX
68175-1011	31-315-RFX	31-321-10RFX	31-4427	31-5556-1RFX
68175-11RFX	31-320	31-325	31-5556-RFX†	

**Fig. 2**

BNC Crimp Plugs

31-351
31-359
31-371

## BNC 3-PIECE CRIMP CABLE PLUGS

Cable RG-/U	Cable Attachment		Dimensions, inches (millimeters)			Notes			Military Number	Amphenol Number	Fig.
	Outer	Inner	a ■	b	c •	CAI	Pit.	Ins.			
6 TYPE (.314 OD)	Crimp	Crimp	1.17(29.7)	.571(14.5)	.314(8.0)	C26	P7	D23	—	31-5558-RFX	1
55, 142, 223, 400	Crimp	Crimp	1.27(32.1)	.563(14.3)	.220(5.59)	C26	P15	D1	—	36875*	1
	Crimp	Crimp	1.20(30.5)	.563(14.3)	.220(5.59)	C26	P15	D1	M23329/3-02,3-04	31-326*	1
	Crimp	Crimp	1.11(28.2)	.563(14.3)	.220(5.59)	C26	P7	D26	—	31-326-RFX	1
	Crimp	Press Fit	1.31(33.3)	.571(14.5)	.212(5.4)	C7R	P7	D23	—	31-5557-RFX†	1
58, 141	Crimp	Crimp	1.11(28.2)	.563(14.3)	.206(5.2)	C26	P15	D1	M23329/3-01,3-03	31-5800	☆
	Crimp	Crimp	1.17(29.8)	.571(14.5)	.210(5.3)	C26	P7	D26	—	31-320-RFX	1
	Crimp	Solder	1.47(37.3)	.562(14.3)	.206(5.2)	C26b	P15	D1	—	31-351*	2
	Crimp	Crimp	1.09(27.8)	.563(14.3)	.206(5.23)	C26	P33	D1	M39012/16-0013	31-4320*	1
	Crimp	Crimp	1.28(32.6)	.571(14.5)	.181(4.6)	C26	P7	D26	—	36650-3RFX	1
	Crimp	Press Fit	1.31(33.3)	.571(14.5)	.260(6.6)	C7R	P7	D23	—	31-5556-RFX†	1
59 (20 AWG Ctr. Contact)	Crimp	Crimp	1.11(28.2)	.563(14.3)	.260(6.6)	C26	P15	D26	—	31-5900	☆
59	Crimp	Crimp	1.12(28.5)	.562(14.3)	.261(6.6)	C26	P15	D1	M23329/3-05	31-321*	1
	Crimp	Crimp	1.17(29.8)	.571(14.5)	.260(6.6)	C26	P7	D26	—	31-321-RFX	1
	Crimp	Solder	1.47(37.3)	.563(14.3)	.261(6.6)	C26b	P15	D1	—	31-359*	2
59 (20 AWG Ctr. Cond.)	Crimp	Crimp	1.12(28.5)	.562(14.3)	.261(6.6)	C26	P33	D1	M39012/16-0015	31-4321	1
	Crimp	Crimp	1.11(28.2)	.562(14.3)	.261(6.6)	C26	P15	D1	—	68175-1005	1
	Crimp	Crimp	1.17(29.8)	.571(14.5)	.260(6.6)	C26	P7	D26	—	68175-5RFX	1
142, 400 Plenum 59, 62	Crimp	Crimp	1.11(28.2)	.563(14.3)	.220(5.6)	C26	P33	D1	M39012/16-0503	31-4427*	1
	Crimp	Crimp	1.28(32.6)	.571(14.5)	.212(5.4)	C26	P7	D26	—	68175-11RFX	1
	Crimp	Press Fit	1.31(33.3)	.571(14.5)	.212(5.4)	C7R	P7	D23	—	31-5560-RFX†	1
174, 179, 187, 188, 316	Crimp	Solder	1.34(34.1)	.563(14.3)	.128(3.25)	C26b	P15	D9	—	31-371*	2
174, 188, 316	Crimp	Crimp	1.19(30.2)	.562(14.3)	.125(3.2)	C26	P15	D1	—	31-315	1
	Crimp	Crimp	1.19(30.2)	.571(14.5)	.106(2.7)	C26	P7	D23	—	31-315-RFX	1
	Crimp	Crimp	1.19(30.2)	.562(14.3)	.117(3.0)	C26	P15	D1	—	31-242*	1
179, 187	Crimp	Crimp	1.19(30.2)	.571(14.5)	.106(2.7)	C26	P7	D23	—	31-242-RFX	1
	Crimp	Crimp	1.11(28.2)	.562(14.3)	.135(3.4)	C26	P16	D1	—	31-315-1005	1
DbL. Br. RG-316	Crimp	Crimp	1.11(28.2)	.562(14.3)	.135(3.4)	C26	P16	D1	—	31-315-1005	1
Belden 8213	Crimp	Crimp	1.59(40.5)	.562(14.3)	.418(10.6)	C26	P17	D1	—	31-4411	1
Belden 8218	Crimp	Crimp	1.11(28.2)	.562(14.3)	.175(4.4)	C26	P15	D1	—	31-325*	1
Belden 8281, 88281	Crimp	Crimp	1.21(30.7)	.562(14.3)	.342(8.7)	C26	P15	D1	—	31-321-1000*	1
	Crimp	Crimp	1.17(29.8)	.571(14.5)	.334(8.5)	C26	P7	D26	—	31-321-10RFX	1
Belden 9259	Crimp	Crimp	1.11(28.2)	.562(14.3)	.261(6.6)	C26	P15	D1	—	68175-1003	1
Belden 9907, 89907	Crimp	Crimp	1.11(28.2)	.562(14.3)	.196(5.0)	C26	P15	D1	—	31-320-1006	1
Belden 1560A, 82259, 89259, Plenum 59, 62	Crimp	Crimp	1.11(28.2)	.563(14.3)	.220(5.6)	C26	P15	D1	—	68175-1011	1
Belden 82907, 88240, 89907, Plenum 58	Crimp	Crimp	1.11(28.2)	.563(14.3)	.175(4.4)	C26	P15	D1	—	36650-1003	1
Plenum 58	Crimp	Press Fit	1.28(32.6)	.571(14.5)	.181(4.6)	C26	P7	D26	—	36650-3RFX	1
Plenum 58	Crimp	Press Fit	1.03(25.0)	.563(14.3)	.213(4.6)	C26	P7	D28	—	31-5559-1RFX	1
Plenum 58	Crimp	Press Fit	1.03(25.0)	.563(14.3)	.26(4.6)	C7R	P7	D23	—	31-5556-1RFX	1

\* recognized under the component program of U.L., Inc. • accommodates cable diameter ☆ see Fig. 1 and table on page 109. ▲ distributor stocked  
■ includes outer ferrule † features preinstalled center contact

Fig. 1

BNC Crimp Plugs for Networking

**31-5800**  
**31-5900**

Fig. 2

BNC Clamp Plugs

<b>6775</b>	<b>31-2</b>	<b>31-3202</b>
<b>9350</b>	<b>31-2-RFX</b>	<b>31-3301</b>
<b>15875</b>	<b>31-202</b>	<b>31-3302</b>
<b>16300</b>	<b>31-212</b>	
<b>69475</b>	<b>31-212-1005</b>	
<b>84975</b>	<b>31-212-RFX</b>	

## BNC CRIMP-CRIMP CABLE PLUGS FOR NETWORKING

Cable RG-/U	Dimensions, inches (millimeters)				Notes			Amphenol Number	Fig.
	a ■	b	c • 1	c • 2	CAI	Plt.	Ins.		
58, 58A, 58B, 58C, 141, Plenum 58, Belden 9907, 89907, Comscope 2104K, 2135, 3104	1.11(28.2)	.563(14.3)	.209(5.3)	.181(4.60)	C26	P15	D26	<b>31-5800</b>	1 ▲
59 & 62, RG-59 20GACC, Plenum 59 & 62; Belden 1515A, 8212, 8221, 8241, 8241A, 8241F, 8263, 8279A, 9100, 9209, 9209A, 9240, 9244, 9259, 9274, 9275, 9659, 1426A, 82108, 88241, 82241, 89259, 82259, 1506A; AT&T 734A; Comscope 5553, 2020K, 3037V, 2249K	1.11(28.2)	.563(14.3)	.261(6.6)	.220(5.59)	C26	P15	D26	<b>31-5900</b>	

## BNC CLAMP CABLE PLUGS

Cable RG-/U	Cable Attachment		Dimensions, inches (millimeters)			Notes			Military Number	Amphenol Number	Fig.
	Outer	Inner	a ■	b	c •	CAI	Plt.	Ins.			
<b>6</b>	Clamp	Solder	1.25(31.8)	.563(14.3)	.348(8.8)	C25	P1	D6	—	<b>9350*</b>	▲ ▲ ▲ ▲ ▲ ▲ ▲ ▲ ▲ ▲ ▲ ▲ ▲ ▲ ▲
<b>8, 9, 11, 213, 214</b>	Clamp	Solder	1.66(42.1)	.688(17.5)	.437(11.1)	C25	P1	D1	UG-959/U	<b>6775*</b>	
<b>55, 58, 141, 142, 223, 400</b>	Clamp	Solder	1.06(27.0)	.562(14.3)	.224(5.7)	C25	P1	D1	UG-88C/U	<b>31-202*</b>	
	Clamp	Solder	1.06(27.0)	.563(14.3)	.221(5.6)	C25	P1	D1	UG88E/U	<b>31-3202*</b>	
<b>58, 141, 142, 400</b>	Clamp	Solder	.969(24.6)	.563(14.3)	.212(5.38)	C25	P1	D1	UG-88/U	<b>31-2*</b>	
	Clamp	Solder	1.07(27.2)	.571(14.5)	.212(5.38)	C25	P7	D23	—	<b>31-2-RFX</b>	
	Clamp	Solder	1.06(27.0)	.563(14.3)	.224(5.7)	C25	P33	D1	M39012/16-0101	<b>31-3301*</b>	
<b>59, 62, 71, 140, 210, 302</b>	Clamp	Solder	1.10(27.9)	.562(14.3)	.255(6.5)	C25	P1	D1	UG260B/U	<b>31-212*</b>	
	Clamp	Solder	1.07(27.2)	.571(14.5)	.256(6.5)	C25	P7	D23	—	<b>31-212-RFX</b>	
	Clamp	Solder	1.06(27.0)	.563(14.3)	.255(6.5)	C25	P33	D1	M39012/16-0102	<b>31-3302*</b>	
<b>59 (20GA CC)</b>	Clamp	Solder	1.06(27.0)	.563(14.3)	.255(6.48)	C25	P1	D1	—	<b>31-212-1005</b>	
<b>122</b>	Clamp	Solder	1.06(27.0)	.563(14.3)	.177(4.5)	C25	P1	D1	UG1033/U	<b>84975*</b>	
<b>174, 179, 187, 188, 316</b>	Clamp	Solder	1.06(27.0)	.563(14.3)	.116(2.9)	C25	P1	D1	—	<b>69475*</b>	
<b>178, 196</b>	Clamp	Solder	1.00(25.4)	.563(14.3)	.094(2.39)	C25	P1	D9	—	<b>15875*</b>	
<b>180</b>	Clamp	Solder	1.00(25.4)	.563(14.3)	.150(3.81)	C25	P1	D9	—	<b>16300*</b>	

"b" dimension is body O.D. • accommodates cable diameter ▲ distributor stocked \* recognized under the component program of U.L., Inc.  
■ includes outer ferrule



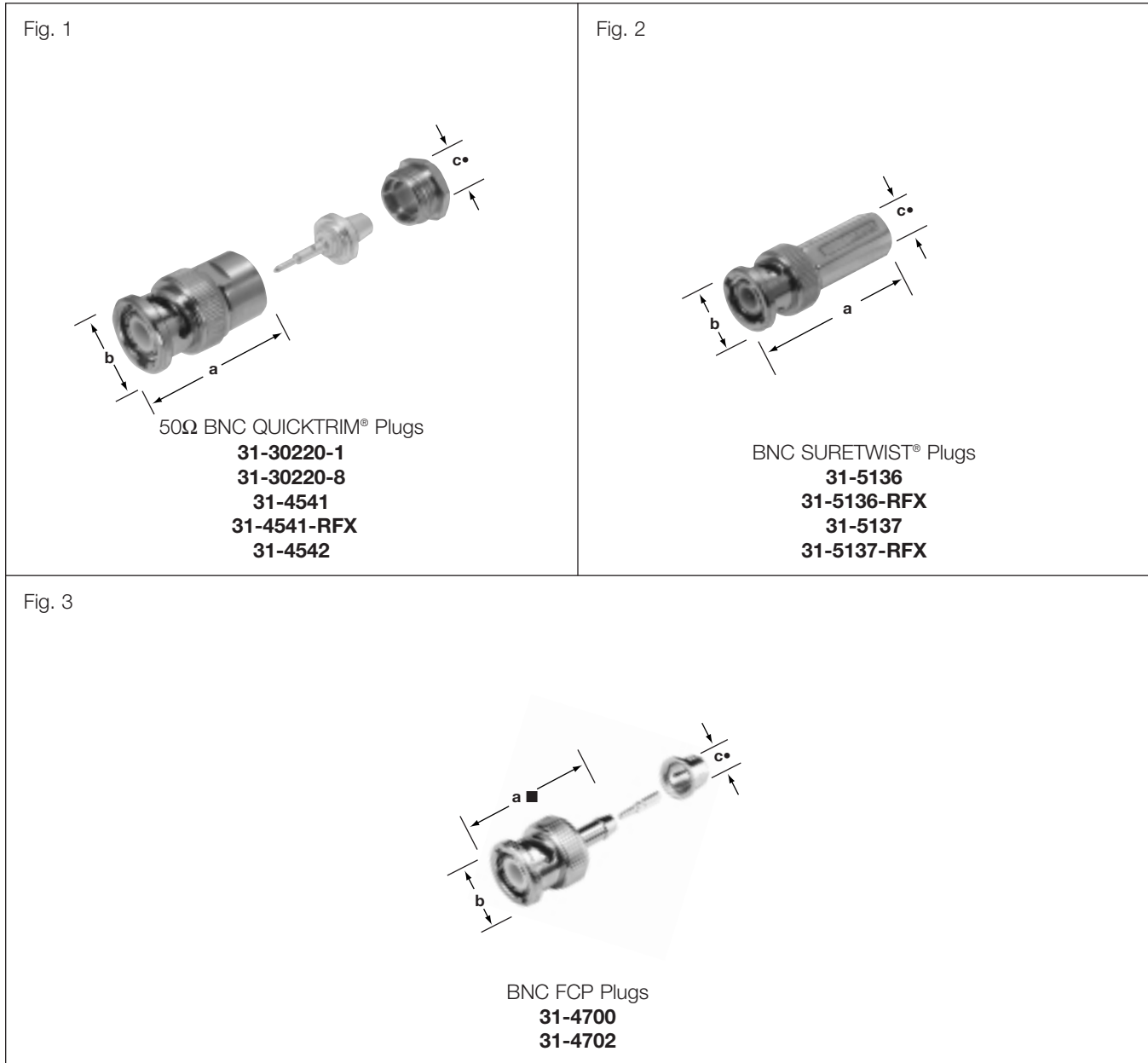

## BNC CABLE PLUGS

Cable RG-/U	Cable Attachment		Dimensions, inches (millimeters)			Notes			Military Number	Amphenol Number	Fig.
	Outer	Inner	a ■	b	c •	CAI	Plt.	Ins.			
58 B/U	SURETWIST®		1.47(37.3)	.562(14.3)	.181(4.6)	C28	P5	D15	—	<a href="#">31-5137</a>	2 ▲
	SURETWIST®		1.48(37.6)	.571(14.5)	.185(4.7)	C28	P7	D23	—	<a href="#">31-5137-RFX</a>	2 ▲
58	FCP	Pliers	1.06(27.0)	.563(14.3)	.206(5.23)	C30	P1	D1	—	<a href="#">31-4700*</a>	3 ▲
	QUICKTRIM®		1.06(27.0)	.563(14.3)	.207(5.3)	C29	P1	D1	—	<a href="#">31-30220-1</a>	1 ▲
59	QUICKTRIM®		1.03(26.2)	.562(14.3)	.252(6.2)	C29	P1	D1	(IBM 1836444)	<a href="#">31-4541</a>	1 ▲
	QUICKTRIM®		1.03(26.2)	.562(14.3)	.252(6.2)	C29	P7	D23	—	<a href="#">31-4541-RFX</a>	1 ▲
	SURETWIST®		1.47(37.3)	.562(14.3)	.242(6.1)	C28	P5	D15	—	<a href="#">31-5136</a>	2 ▲
	SURETWIST®		1.48(37.6)	.571(14.5)	.242(6.1)	C28	P7	D23	—	<a href="#">31-5136-RFX</a>	2 ▲
	FCP	Pliers	1.06(27.0)	.563(14.3)	.259(6.56)	C30	P1	D1	—	<a href="#">31-4702*</a>	3 ▲
223	QUICKTRIM®		1.06(27.0)	.563(14.3)	.225(5.7)	C29	P1	D1	—	<a href="#">31-30220-8</a>	1
Belden 9268	QUICKTRIM®		1.06(27.0)	.563(14.3)	.275(6.99)	C29	P1	D1	(IBM 1836447)	<a href="#">31-4542</a>	1

• accommodates cable diameter \* recognized under the component program of U.L., Inc. ▲ distributor stocked ■ includes outer ferrule



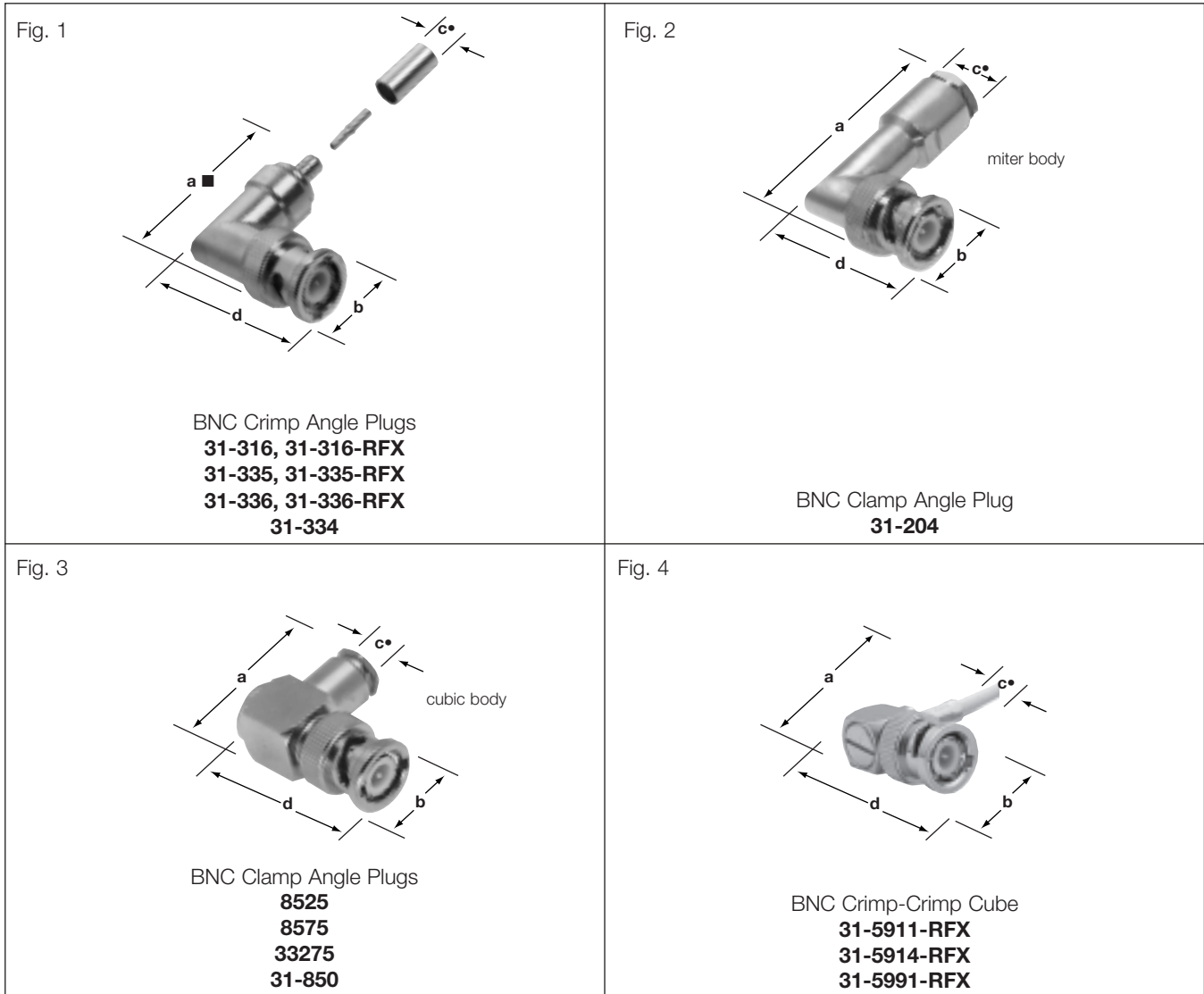

## BNC ANGLE CABLE PLUGS

Cable RG-/U	Cable Attachment		Dimensions, inches (millimeters)				Notes			Military Number	Amphenol Number	Fig.
	Outer	Inner	a	b	c •	d	CAI	Pt.	Ins.			
55, 58, 141, 142, 223, 400	Clamp	Solder	1.68(42.7)■	.562(14.3)	.214(5.5)	1.09(27.8)	C25	P1	D1	UG-913/U	31-204*	2
55, 142, 223, 400	Crimp	Crimp	1.19(30.2)■	.562(14.3)	.220(5.6)	1.59(40.5)	C26a	P15	D1	—	31-334*	1 ▲
58, 141	Crimp	Crimp	1.59(40.5)■	.562(14.3)	.206(5.2)	1.19(30.2)	C26a	P15	D1	—	31-335*	1
	Crimp	Crimp	1.66(42.2)■	.571(14.5)	.210(5.3)	1.07(27.2)	C26a	P7	D23	—	31-335-RFX	1
58, 141, 142, 400	Clamp	Solder	1.00(25.4)■	.562(14.3)	.212(5.4)	1.25(31.8)	C25	P1	D1	(Cubic Body)	8525*	3
59, 62, 71, 140, 210	Clamp	Solder	1.00(25.4)	.562(14.3)	.259(6.6)	1.25(31.8)	C25	P1	D1	—	8575*	3 ▲
	Clamp	Solder	1.25(31.6)	.562(14.3)	.259(6.6)	1.03(26.2)	C25	P1	D6	—	31-850*	3 ▲
59, 62, 140, 210	Crimp	Crimp	1.59(40.5)■	.562(14.3)	.259(6.6)	1.19(30.2)	C26a	P15	D1	—	31-336	1
	Crimp	Crimp	1.66(42.2)■	.571(14.5)	.260(6.6)	1.07(27.2)	C26a	P7	D23	—	31-336-RFX	1
174, 179, 187, 188	Clamp	Solder	1.25(31.6)	.562(14.3)	.115(2.9)	1.00(25.4)	C25	P1	D1	(Cubic Body)	33275*	3 ▲
174, 188, 316	Crimp	Crimp	1.19(30.2)■	.562(14.3)	.115(2.9)	1.59(40.5)	C26a	P15	D1	—	31-316*	1
58, 141	Crimp	Solder	.862(21.9)	.571(14.5)	.214(5.5)	1.07(27.2)	C26a	P7	D23	(Cubic Body)	31-5911-RFX	4
59	Crimp	Solder	.862(21.9)	.571(14.5)	.259(6.6)	1.07(27.2)	C26a	P7	D23	(Cubic Body)	31-5914-RFX	4
316	Crimp	Solder	.862(21.9)	.571(14.5)	.115(2.9)	1.09(27.8)	C26a	P7	D23	(Cubic Body)	31-5991-RFX	4
316 Die Cast	Crimp	Solder	.862(21.9)	.571(14.5)	.115(2.9)	1.07(27.2)	C26a	P7	D23	(Cubic Body)	31-316-RFX	1

■ includes outer ferrule • accommodates cable diameter \* recognized under the component program of U.L., Inc. ▲ distributor stocked

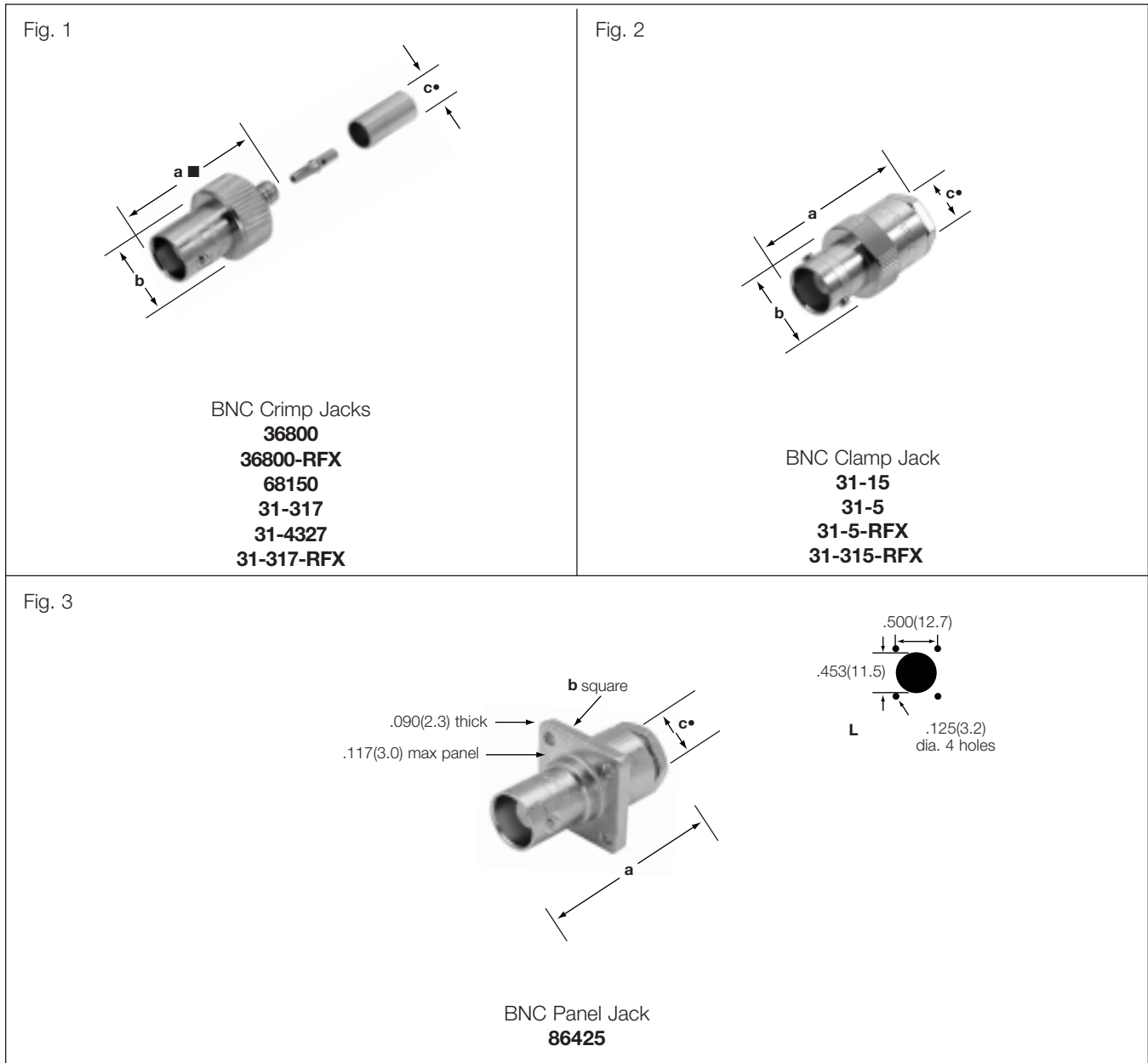

## BNC CABLE JACKS

Cable RG/U	Cable Attachment		Dimensions, inches (millimeters)			Construction Notes			Military Number	Amphenol Number	Fig.
	Outer	Inner	a ■	b	c •	CAI	Plt.	Ins.			
58, 141	Crimp	Crimp	1.17(29.8)	.562(14.3)	.206(5.2)	C26a	P33	D1	M39012/17-0013	31-4327*	1
	Crimp	Crimp	1.17(29.7)	.510(13.0)	.206(5.2)	C26a	P15	D1	—	36800*	1
	Crimp	Crimp	1.32(33.5)	.435(11.0)	.210(5.3)	C26a	P7	D23	—	36800-RFX	1
59, 62, 71, 140, 210	Clamp	Solder	1.14(29.0)	.562(14.3)	.259(6.6)	C25	P1	D1	UG-261/U	31-15*	2 ▲
174, 188, 316	Crimp	Crimp	1.19(30.2)	.571(14.5)	.106(2.7)	C26a	P15	D23	—	31-315-RFX	2
223	Clamp	Solder	1.14(29.0)	.562(14.3)	.220(5.0)	C25	P1	D1	UG-89/U	31-5	2 ▲
174, 188, 316	Crimp	Crimp	1.07(27.3)	.453(11.5)	.106(2.7)	C26a	P15	D23	—	31-317-RFX	1
174, 188, 316	Crimp	Crimp	1.39(35.3)	.562(14.3)	.125(3.2)	C26a	P15	D1	—	31-317*	1
174, 179, 187, 188, 316	Clamp	Solder	1.14(29.0)	.687(17.5)	.117(3.0)	C25	P1	D1	—	86425*	3
59, 62, 140, 210	Crimp	Crimp	1.18(30.0)	.510(13.0)	.261(6.6)	C26a	P15	D1	—	68150*	1 ▲
223	Clamp	Clamp	1.14(29.0)	.562(14.3)	.220(5.0)	C25	P1	D1	—	31-5-RFX	2

• accommodates cable diameter \* recognized under the component program of U.L., Inc. ▲ distributor stocked ■ includes outer ferrule

Fig. 1

BNC Crimp Bulkhead Jacks

<b>95700</b>	<b>31-318-RFX</b>
<b>31-245</b>	<b>31-342</b>
<b>31-245-RFX</b>	<b>31-342-RFX</b>
<b>31-318</b>	<b>31-343-1002</b>
<b>31-318-1001</b>	<b>31-343-RFX</b>

Fig. 2

BNC Clamp Bulkhead Jacks

<b>86350</b>
<b>86850</b>
<b>31-206</b>
<b>31-207</b>

## BNC BULKHEAD CABLE JACKS

Cable RG-/U	Cable Attachment		Dimensions, inches (millimeters)					CAI	Pit.	Ins.	Mtg. Hole	Military Number	Amphenol Number	Fig.
	Outer	Inner	a ■	b	c •	d	e							
55, 142, 223	Crimp	Crimp	1.41(35.8)	.795(20.2) dia	.220(5.6)	.812(20.6)	.250(6.4)	C26a	P17	D1	Y	—	95700*	1
58, 141	Crimp	Crimp	1.41(35.7)	.795(20.2) dia	.206(5.2)	.812(20.6)	.250(6.4)	C26a	P15	D1	Y	—	31-342	1 ▲
58, 141, 142, 223	Crimp	Crimp	1.38(35.1)	.687(17.5) hex	.210(5.3)	.709(18.0)	.138(3.5)	C26a	P7	D23	Y	—	31-342-RFX	1 ▲
58, 141, 142, 400	Clamp	Solder	1.12(28.6)	.687(17.6) hex	.224(5.7)	.798(20.3)	.218(5.5)	C25	P1	D1	Y	UG-909/U	31-206*	2
59, 62, 140, 210	Clamp	Solder	1.12(28.6)	.687(17.6) hex	.257(6.5)	.798(20.3)	.218(5.5)	C25	P1	D1	Y	UG-910/U	31-207*	2
	Crimp	Crimp	1.38(35.1)	.687(17.5) hex	.260(6.6)	.709(18.0)	.138(3.5)	C26a	P7	D23	Y	—	31-343-RFX	1
Plenum 59 (20 AWG)	Crimp	Crimp	1.41(35.8)	.795(20.2) dia	.220(5.6)	.812(20.6)	.250(6.4)	C26a	P15	D1	Y	—	31-343-1002	1
174,179,187,188,316	Clamp	Solder	1.14(29.0)	.687(17.5) hex	.115(2.9)	.798(20.3)	.250(6.4)	C25	P1	D1	Y	—	86350*	2 ▲
174, 188, 316	Crimp	Crimp	1.48(37.0)	.795(20.2) dia	.120(3.0)	.812(20.6)	.250(6.4)	C26a	P16	D1	Y	—	31-318*	1 ▲
	Crimp	Crimp	1.43(36.4)	.687(17.5) hex	.106(2.7)	.812(20.6)	.138(3.5)	C26a	P7	D23	Y	—	31-318-RFX	1 ▲
178, 196	Clamp	Solder	1.14(29.0)	.687(17.5) dia	.098(2.5)	.798(20.3)	.250(6.4)	C25	P1	D1	Y	—	86850*	2
179, 187	Crimp	Crimp	1.49(37.8)	.795(20.2) dia	.120(3.0)	.812(20.6)	.250(6.4)	C26a	P15	D1	Y	—	31-245*	1
	Crimp	Crimp	1.43(36.3)	.687(17.4) hex	.106(2.7)	.709(18.0)	.138(3.5)	C26a	P7	D23	Y	—	31-245-RFX	1
Dbl. Br. 316	Crimp	Crimp	1.41(35.8)	.795(20.2) dia	.135(3.42)	.812(20.6)	.250(6.4)	C26a	P15	D1	Y	—	31-318-1001	1

● accommodates cable diameter \* recognized under the component program of U.L., Inc. ▲ distributor stocked ■ includes outer ferrule

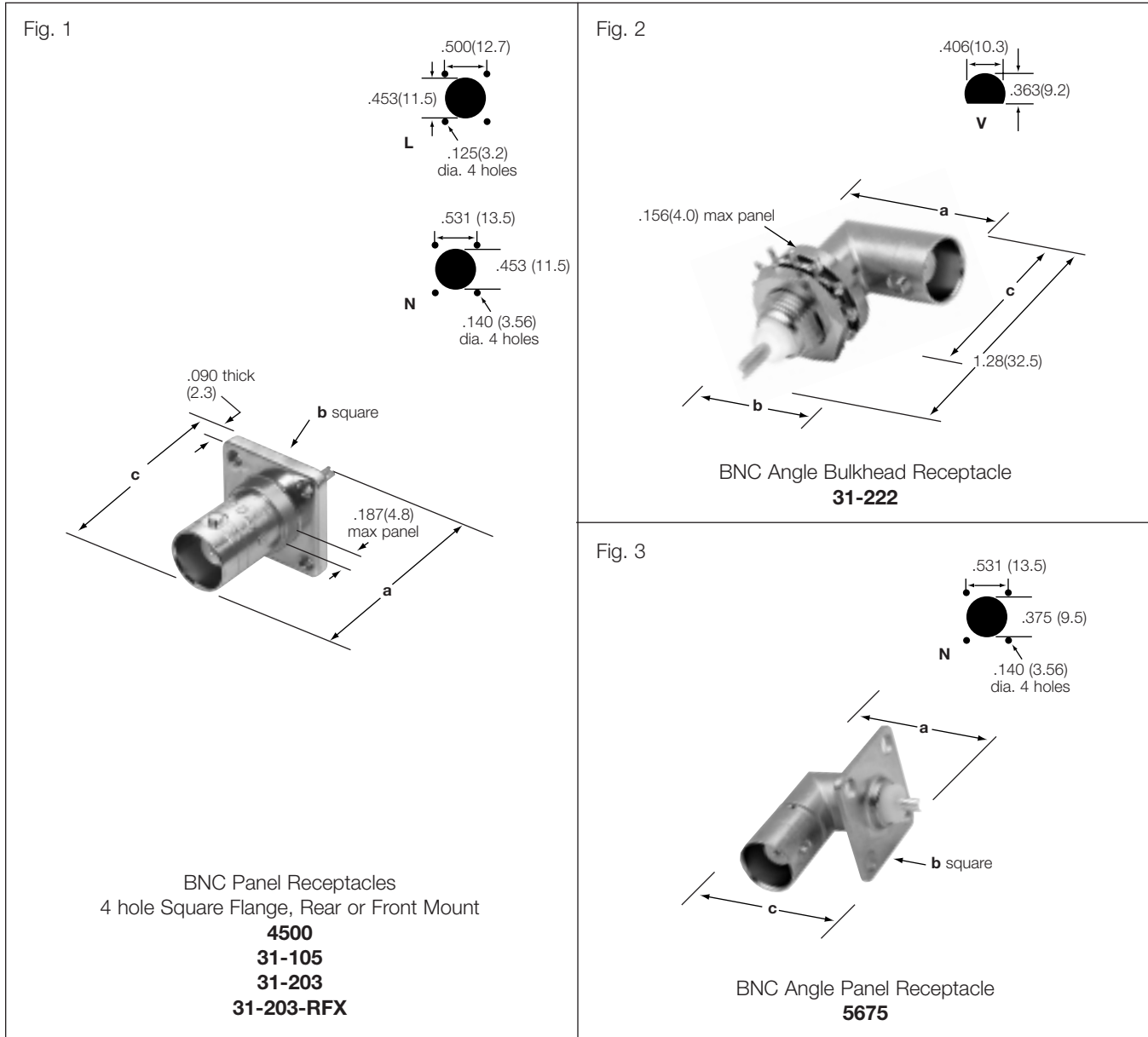

## BNC PANEL AND ANGLE BULKHEAD RECEPTACLES

Description	Terminal Type	Dimensions, inches (millimeters)			Notes		Mtg. Hole	Military Number	Amphenol Number	Fig.
		a	b	c	Pit.	Ins.				
Panel Receptacle 4 hole Square Flange No. 3-56 Tapped Flange Holes	Solder Cup	1.06(27.0)	.687(17.5)	.719(18.3)	P1	D1	L	UG-290A/U	<b>31-203</b>	1
Panel Receptacle 4 hole Square Flange .125" Dia. Flange Holes	Solder Cup	1.06(27.0)	.687(17.5)	.719(18.3)	P7	D23	L	—	<b>31-203-RFX</b>	
Panel Receptacle 4 hole Square Flange .120" Dia. Flange Holes, Styrene Ins.	Solder Cup	1.03(26.2)	.687(17.5)	.719(18.3)	P1	D6	L	—	<b>31-105*</b>	
Panel Receptacle 4 hole Square Flange .136" Dia. Flange Holes, Styrene Ins.	Turret	1.08(27.4)	.750(19.1)	.609(15.5)	P1	D6	N	UG-185/U	<b>4500*</b>	2
Angle, External Tooth Lockwasher	Solder Cup	.906(23.0)	.594(15.1)	.625(15.8)	P1	D1	V	UG-1098/U	<b>31-222*</b> □	
Angle Panel Receptacle 4 hole Flange .136"(3.5mm) Diameter Holes	Solder Cup	.928(23.6)	.642(16.3)	.642(16.3)	P1	D1	N	UG-535/U	<b>5675*</b>	3

\* recognized under the component program of U.L., Inc. ▲ distributor stocked □ IBM 01620666

# BNC 50 ohm Bulkhead Receptacles

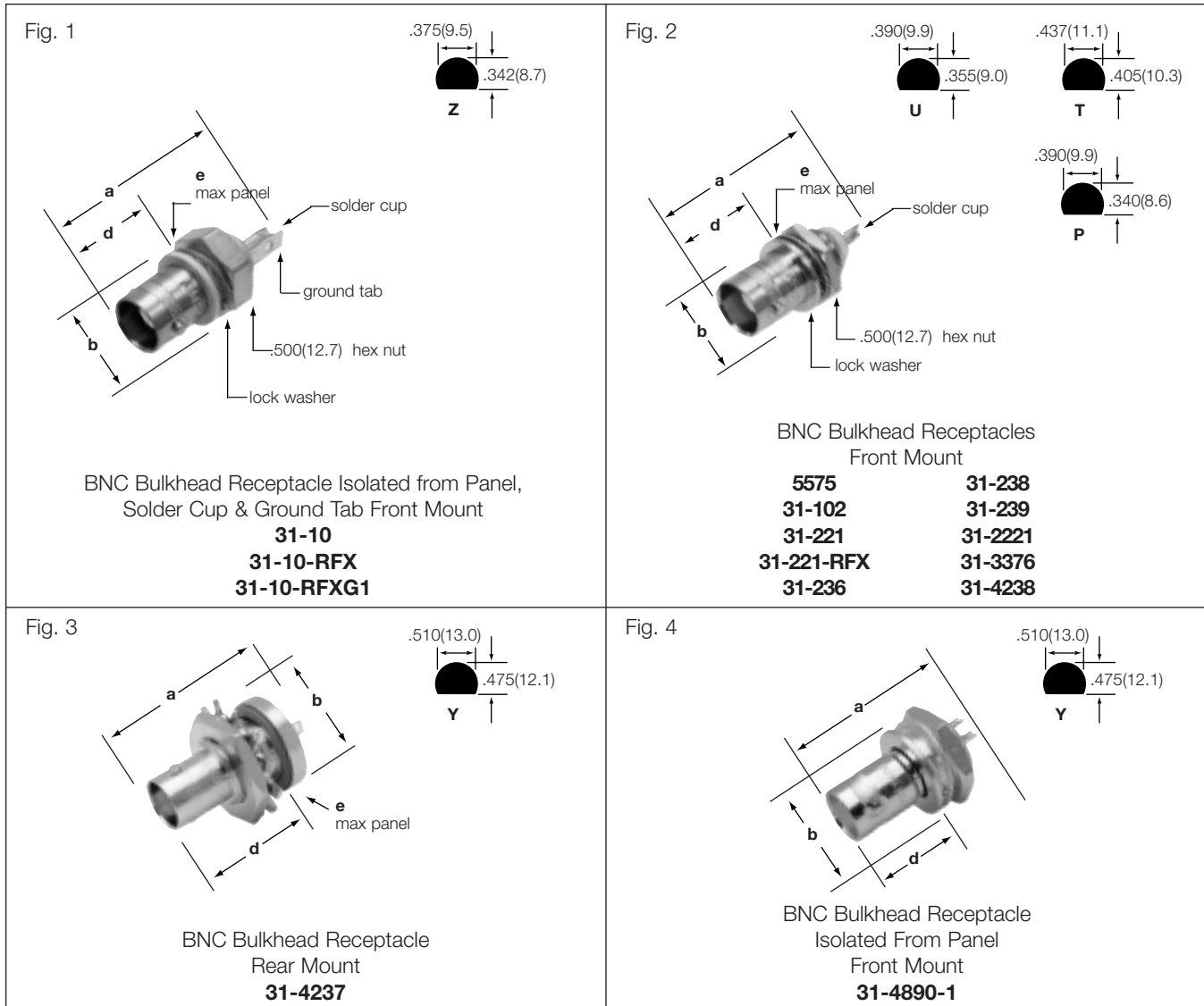

## BNC BULKHEAD RECEPTACLES

Description	Terminal Type	Dimensions, inches (mm)				Notes		Mtg. Hole	Military Number	Amphenol Number	Fig.
		a	b	d	e	Plt.	Ins.				
Front Mount, Isolated from Panel	Solder Cup	1.19(30.2)	.500(12.7)	.471(12.0)	.187(4.8)	P1	D22	Z	—	<b>31-10*</b>	1 ▲
	Solder Cup	1.18(30.0)	.500(12.7)	.471(12.0)	.125(3.2)	P1	D22	Z	—	<b>31-10-RFX</b>	1 ▲
Front Mount	Solder Cup	1.18(30.0)	.500(12.7)	.471(12.0)	.187(4.8)	P7	D22	Z	—	<b>31-10-RFXG1</b>	1 ▲
Front Mount	Solder Cup	1.06(27.0)	.500(12.7)	.484(12.3)	.125(3.2)	P1	D1	U	UG-1094/U	<b>31-221*†</b>	2 ▲
		1.06(27.0)	.500(12.7)	.472(12.0)	.125(3.2)	P7	D23	U	—	<b>31-221-RFX</b>	2 ▲
		1.06(27.0)	.500(12.7)	.469(11.9)	.156(4.0)	P1	D1	T	UG-625B/U	<b>31-236*</b>	2 ▲
		1.19(30.2)	.500(12.7)	.481(12.3)	.250(6.4)	P1	D1	U	UG-1094A/U	<b>31-2221</b>	2
Front Mount, Gold Plated Contact	Solder Cup	1.19(30.2)	.500(12.7)	.484(12.3)	.250(6.4)	P34	D1	U	M39012/21-0002	<b>31-3376*</b>	2
Front Mount, Pressurized	Solder Cup	1.30(32.9)	.578(14.7)	.594(15.1)	.250(6.4)	P1	D9	P	UG-657A/U	<b>31-239*</b>	2 ▲
Front Mount, Pressurized	Solder Cup	1.30(32.9)	.578(14.7)	.594(15.1)	.250(6.4)	P1	D9	P	UG-657/U	<b>31-102*</b>	2
Fr. Mount, Gold Plated Contact	Spade	1.20(30.6)	.594(15.1)	.516(13.1)	.250(6.4)	P33	D1	U	M39012/24-0002	<b>31-4238*</b>	2
Hermetic External Tooth Lockwasher	Spade	1.20(30.6)	.594(15.1)	.516(13.1)	.250(6.4)	P1	D1/11	U	UG-912/U	<b>31-238*</b>	2
Front Mount	Solder Cup	1.06(27.0)	.500(12.7)	.472(12.0)	.156(4.0)	P1	D1	T	UG-625/U	<b>5575*</b>	2 ▲
Rear Mount, Hermetic	Spade	1.34(34.0)	.687(17.4)	.831(21.1)	.250(6.4)	P33	D1/11	Y	M39012/24-0001	<b>31-4237*</b>	3
Front Mount Isolated from Panel Metal Mounting Threads	Solder Cup	1.06(27.0)	.625(15.9)	.571(14.5)	.187(4.7)	P4	D1	Y	—	<b>31-4890-1</b>	4

\* recognized under the component program of U.L., Inc. ▲ distributor stocked † includes grounding lug



Fig. 1

Standard Height 50 ohm BNC Printed Circuit Board Right Angle Bulkhead Receptacles ☆

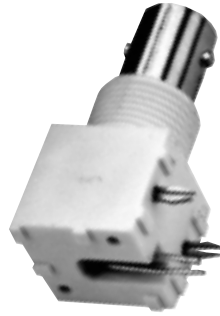
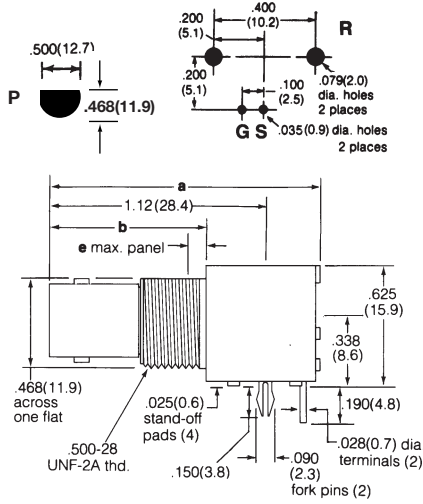

Isolated from Panel  
White Valox Housing  
**31-5431▲** (Round Pins)  
**31-5431-1010** (Fork Pins)  
**31-5431-10RFX**



Isolated from Panel  
Black Valox Housing  
**31-5538** (Round Pins)  
**31-5538-1010** (Fork Pins)  
**31-5538-10RFX**

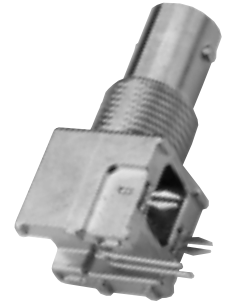

Metal Housing  
**31-5640▲** (Round Pins)  
**31-5640-1010** (Fork Pins)

Fig. 2

Low Profile 50 ohm BNC Printed Circuit Board Bulkhead Receptacles ☆

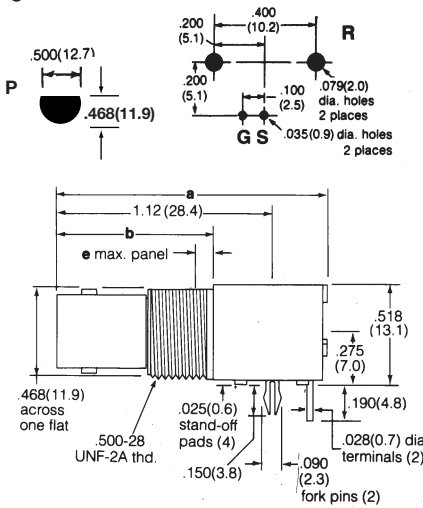

Isolated from Panel  
White Valox Housing  
**31-5486▲** (Round Pins)  
**31-5486-1010** (Fork Pins)  
**31-5486-10RFX**



Isolated from Panel  
Black Valox Housing  
**31-5540** (Round Pins)  
**31-5540-1010** (Fork Pins)  
**31-5540-10RFX**



Metal Housing  
**31-5637** (Round Pins)

Fig. 3

Vertical 50 ohm BNC Printed Circuit Board Bulkhead Receptacles ☆

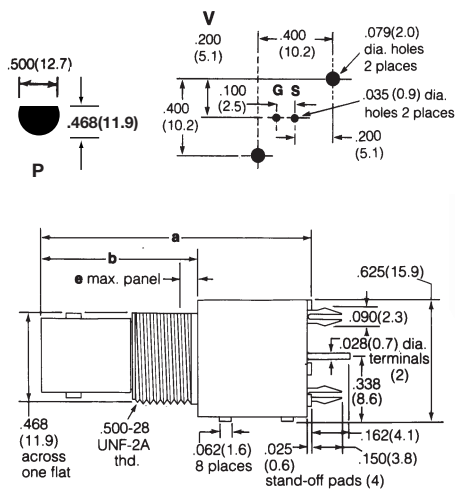

Isolated from Panel  
White Valox Housing  
**31-5493▲** (Round Pins)  
**31-5493-1010** (Fork Pins)







Isolated from Panel  
Black Valox Housing  
**31-5539** (Round Pins)  
**31-5539-1010▲** (Fork Pins)  
**31-5539-10RFX**

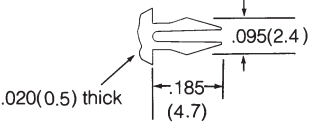

Metal Housing  
**31-5633** (Round Pins)  
**31-5633-1010** (Fork Pins)

▲ distributor stocked ☆ Jam nuts and lockwashers sold separately.

# BNC 50 ohm PCB Receptacles and Accessories

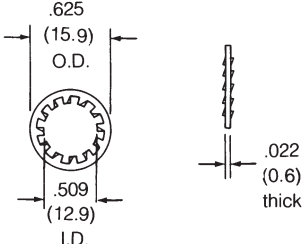
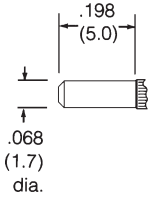
 <p>Fork Pin holds connectors rigidly to P.C. Board for high temperature and mass production assembly</p>	<p>Fig. 4</p>   <p>Pkg. of 100, Hex Nut for BNC Bulkhead PCB Receptacles <b>31-5652▲</b> Nickel Plated</p>	<p>Fig. 5</p>   <p>Pkg. of 100, Lockwasher for BNC PCB Bulkhead Receptacles <b>31-5653▲</b> Nickel Plated</p>
 <p>Round Pin (Standard)</p>		

## BNC PRINTED CIRCUIT BOARD BULKHEAD RECEPTACLES AND ACCESSORIES

Description	Terminal Type	Dimensions, inches (millimeters)			Notes		Mtg. Hole	Notes	MTG. Pin Type	Imp	Amphenol Number	Fig.
		a	b	e	Pit.	Ins.						
Standard Height Printed Circuit Angle Bulkhead Receptacle (J)☆	Blunt Posts for Signal & Ground	1.40(35.6)	.810(20.6)	.250(6.4)	P26	D17	R/P	Iso. White Housing	Round	50Ω	<b>31-5431</b>	1
					P26	D17	Fork		50Ω	<b>31-5431-1010</b>		
					P26	D20		R/P	Iso. Black Housing	Round	50Ω	
					P26	D20	Stamp			50Ω	<b>31-5538-10RFX</b>	
					P26	D22	R/P	Metal Housing	Round	50Ω	<b>31-5640</b>	
					P26	D22			Fork	50Ω	<b>31-5640-1010</b>	
					P25	D17	R/P	Iso. White Housing	Stamp	50Ω	<b>31-5431-10RFX</b>	
Low Profile Printed Circuit Angle Bulkhead Receptacle (J)☆	Blunt Posts for Signal & Ground	1.40(35.6)	.810(20.6)	.250(6.4)	P26	D17	R/P	Iso. White Housing	Round	50Ω	<b>31-5486</b>	2
					P26	D17	Fork		50Ω	<b>31-5486-1010</b>		
					P26	D20		R/P	Iso. Black Housing	Round	50Ω	
					P26	D20	Fork			50Ω	<b>31-5540-1010</b>	
					P26	D22	R/P	Metal Housing	Round	50Ω	<b>31-5637</b>	
Vertical Printed Circuit Bulkhead Receptacle (J)☆	Blunt Posts for Signal & Ground	1.40(35.6)	.810(20.6)	.250(6.4)	P26	D17	V/P	Iso. White Housing	Round	50Ω	<b>31-5493</b>	3
					P26	D17			Fork	50Ω	<b>31-5493-1010</b>	
					P26	D20	V/P	Iso. Black Housing	Round	50Ω	<b>31-5539</b>	
					P26	D20			Fork	50Ω	<b>31-5539-1010</b>	
					P26	D22	V/P	Metal Housing	Round	50Ω	<b>31-5633</b>	
					P26	D22			Fork	50Ω	<b>31-5633-1010</b>	
					P25	D13	R/P	Iso. White Housing	Stamp	50Ω	<b>31-5486-10RFX</b>	
					P25	D20	R/P	Iso. Black Housing	Stamp	50Ω	<b>31-5540-10RFX</b>	
Hex Nut for BNC Bulkhead PCB Receptacles, Package of 100 ea.					P3	—	—	Nickel Plated	—	—	<b>31-5652</b>	4
Lockwasher for BNC Bulkhead PCB Receptacles, Package of 100 ea.					P3	—	—	Nickel Plated	—	—	<b>31-5653</b>	5

☆ Jam nuts and lockwashers sold separately. See Figs. 4 & 5 ▲ distributor stocked

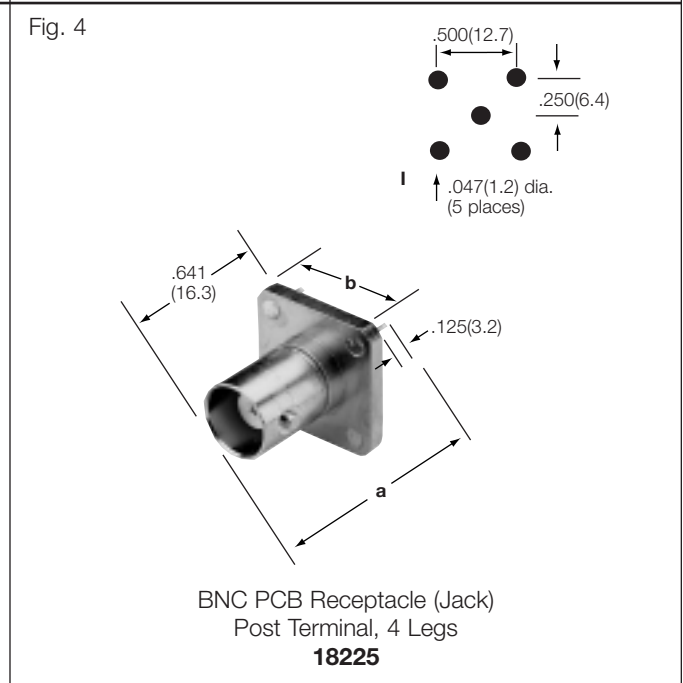
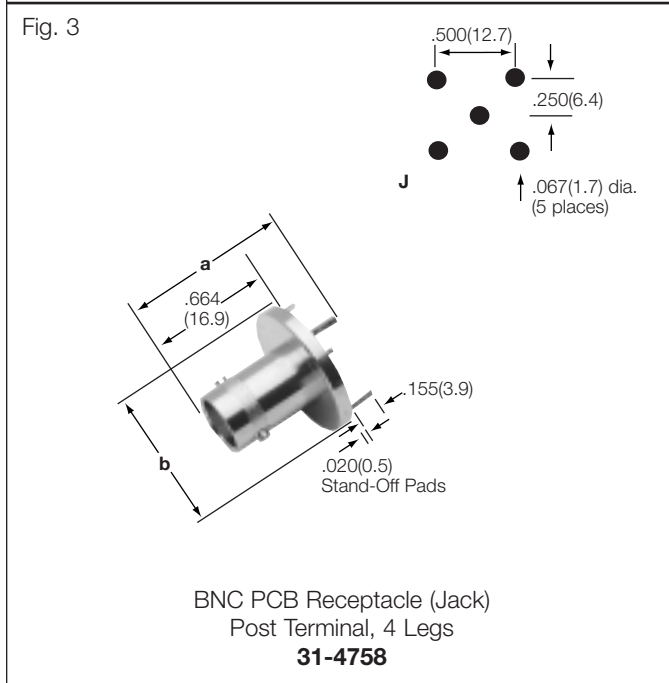
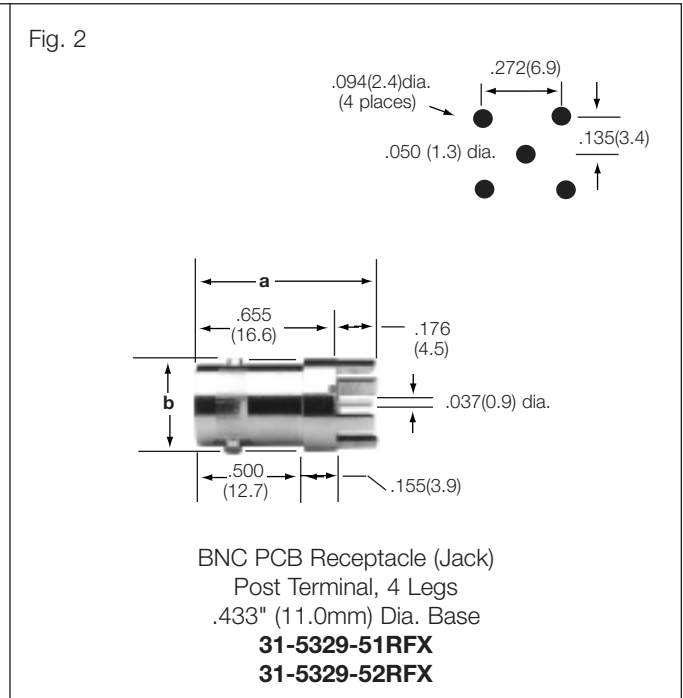
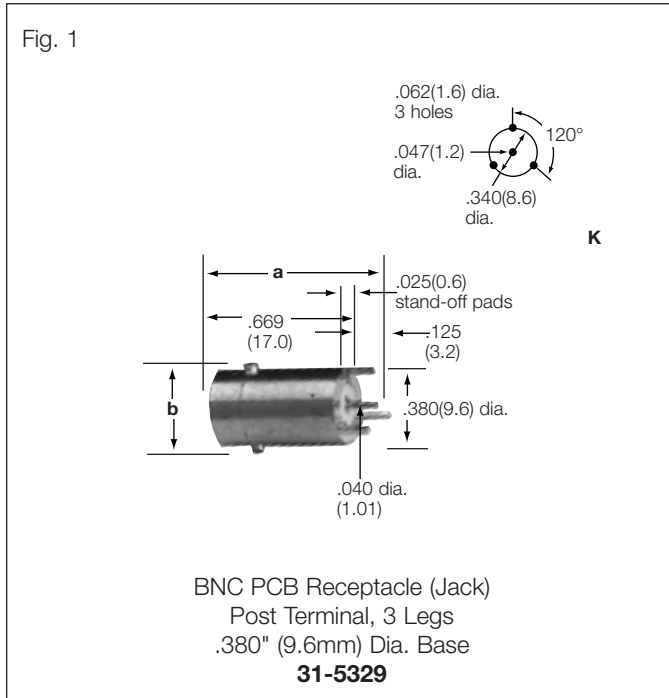

## PRINTED CIRCUIT BOARD RECEPTACLES

Description	Terminal Type	Dimensions, inches (mm)		Notes			Mtg. Hole	Amphenol Number	Fig.
		a	b	Pit.	Ins.	Imp.			
PCB Receptacle, 3 Legs .125(3.2) Long/Post Terminal .040(1.0) Dia. x .125(3.2) Long/.025(0.6) Stand-off Pads	Blunt Post	.794(20.2)	.434(11.0)	P6	D1	50Ω	K	<b>31-5329</b>	1
PCB Receptacle, 4 Legs .176(4.5) Long/Post terminal .037(0.9) Dia.	Blunt Post	.831(21.1)	.433(11.0) dia	P1	D25	50Ω	F	<b>31-5329-51RFX</b>	2 ▲
PCB Receptacle, 4 Legs .176(4.5) Long/Post terminal .037(0.9) Dia.	Blunt Post	.831(21.1)	.433(11.0) dia	P17	D25	50Ω	F	<b>31-5329-52RFX</b>	2 ▲
PCB Receptacle, 4 Legs .155(3.9) Long/.020(0.5) Stand-off Pads/Post terminal .040(1.0) Dia.	Blunt Post	.819(20.8)	.812(20.6) dia	P1	D1	50Ω	J	<b>31-4758</b>	3
PCB Receptacle, 4 Legs and Post Terminal .040(1.0) Dia. x .125(3.2) Long	Blunt Post	.766(19.4)	.688(17.5) dia	P1	D1	50Ω	I	<b>18225</b>	4

▲ distributor stocked



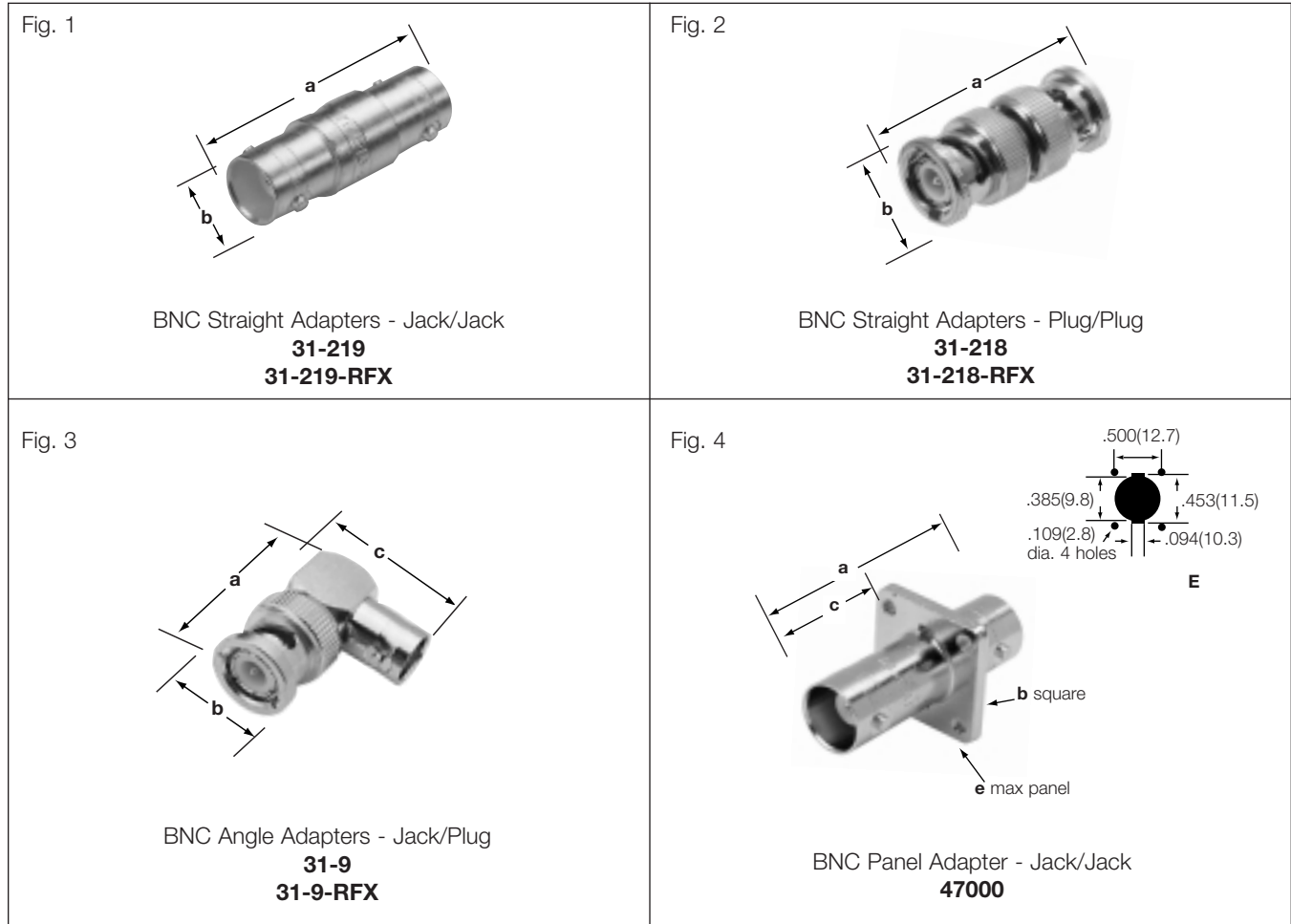

BNC

## BNC ADAPTERS - STRAIGHT, ANGLE, PANEL MOUNT

Description		Dimensions, inches (millimeters)				Notes		Mtg. Hole	Military Number	Amphenol Number	Fig.
		a	b	c	e	Plt.	Ins.				
Straight	Jack-Jack	1.28(32.5)	.437(11.1)	—	—	P1	D1	—	UG-914/U	<b>31-219*</b>	1 ▲
						P7	D26	—	—	<b>31-219-RFX</b>	1 ▲
Straight	Plug-Plug	1.25(31.8)	.562(14.3)	—	—	P1	D1	—	UG-491A/U	<b>31-218*</b>	2 ▲
						P7	D1	—	—	<b>31-218-RFX</b>	2 ▲
Angle	Jack-Plug	1.06(27.0)	.562(14.3)	1.02(25.8)	—	P1	D1	—	UG-306/U	<b>31-9*‡</b>	3 ▲
		1.06(27.0)	.562(14.3)	1.02(25.8)	—	P1	D1	—	—	<b>31-9-RFX</b>	3 ▲
		1.09(27.6)	.594(15.1)	1.02(25.8)	—	P34	D1	—	M55339/14-00306	<b>31-4561</b>	3
Panel, 3-56 Tapped Flange Holes	Jack-Jack	1.28(32.5)	.688(17.5)	.691(17.6)	.250(6.4)	P1	D1	E	—	<b>47000*</b>	4

\* recognized under the component program of U.L., Inc. ▲ distributor stocked ‡ IBM 6028521

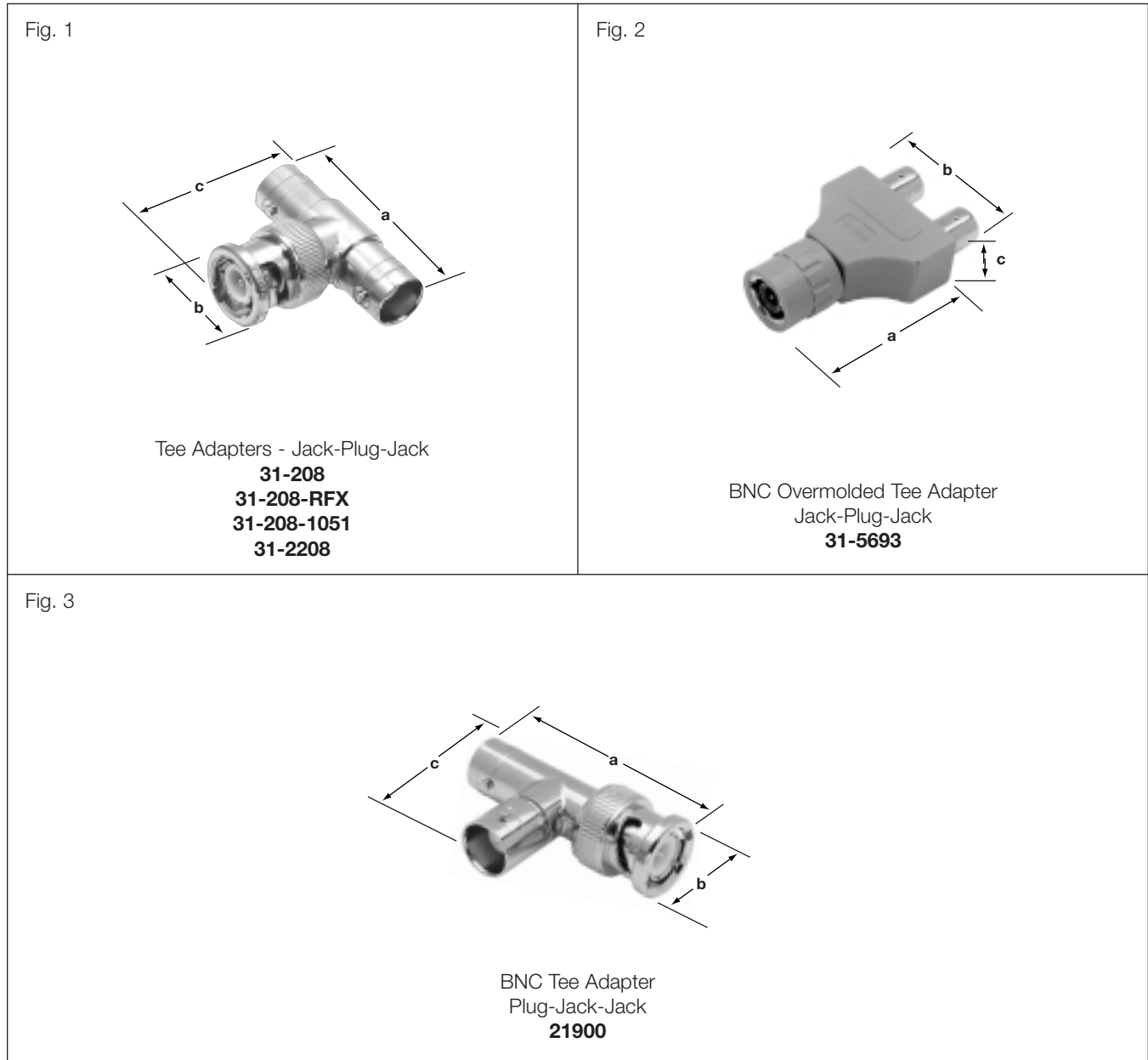

## BNC TEE ADAPTERS

Description		Dimensions, inches (millimeters)			Notes		Military Number	Amphenol Number	Fig.
		a	b	c	Plt.	Ins.			
Tee	Jack-Plug-Jack	1.28(32.5)	.562(14.3)	1.06(27.0)	P1	D1	UG-274A/U	<a href="#">31-208*</a>	1 ▲
Tee	Jack-Plug-Jack	1.30(33.0)	.571(14.5)	1.04(26.3)	P7	D23	—	<a href="#">31-208-RFX</a>	1 ▲
Tee	Jack-Plug-Jack	1.28(32.5)	.562(14.3)	1.06(27.0)	P15	D1	—	<a href="#">31-208-1051</a>	1
Tee	Jack-Plug-Jack	1.28(32.5)	.562(14.3)	1.06(27.0)	P4	D1	UG-274B/U	<a href="#">31-2208*</a>	1
Tee, Overmolded	Jack-Plug-Jack	1.72(43.6)	1.32(33.5)	.550(14.0)	P7	D14	—	<a href="#">31-5693</a>	2 ▲
Tee	Plug-Jack-Jack	1.53(38.9)	.375(9.52)	1.00(25.4)	P1	D9	—	<a href="#">21900*</a>	3

\* recognized under the component program of U.L, Inc. ▲ distributor stocked

Fig. 1

BNC Bulkhead Adapters - Jack/Jack  
**4525**  
**31-220G-RFX**  
**31-220H**  
**31-220N**  
**31-220N-RFX**  
**31-3220**

Fig. 2

BNC Isolated Bulkhead Adapters  
 Jack-Jack  
**31-4803**  
**31-4803-1101**  
**31-4803-RFX**

BNC

## BNC BULKHEAD ADAPTERS

Description		Dimensions, inches (millimeters)				Notes		Mtg. Hole	Military Number	Amphenol Number	Fig.	
		a	b	c	e	Pit.	Ins.					
Sealed, 50 PSI	Jack-Jack	1.40(35.6)	.625(15.9)	.683(17.3)	.187(4.8)	P1	D1	Y	UG-492A/U	<b>31-220H</b> ‡	1	▲
	Jack-Jack	1.53(38.9)	.688(17.5)	.672(17.0)	.281(7.1)	P4	D1	Y	UG-492D/U	<b>31-3220*</b>	1	▲
Gasketed	Jack-Jack	1.56(39.6)	.689(17.5)	.681(17.3)	.295(7.5)	P7	D23	Y	—	<b>31-220G-RFX</b>	1	▲
	Jack-Jack	1.40(35.6)	.800(20.3)	.659(16.7)	.160(4.1)	P1	D1	Y	—	<b>4525*</b>	1	▲
Non-sealed	Jack-Jack	1.40(35.6)	.800(20.3)	.664(16.9)	.187(4.8)	P1	D1	Y	—	<b>31-220N</b>	1	▲
		1.28(32.5)	.610(15.5)	.492(12.5)	.216(5.5)	P7	D23	Y	—	<b>31-220N-RFX</b>	1	▲
Isolated from Panel	Jack-Jack	1.28(32.5)	.625(15.9)	.460(11.7)	.187(4.8)	P1	D12	Y	—	<b>31-4803</b>	2	▲
		1.28(32.5)	.625(15.9)	.460(11.7)	.187(4.8)	P15	D12	Y	—	<b>31-4803-1101</b>	2	
		1.28(32.5)	.625(15.9)	.460(11.7)	.187(4.8)	P15	D12	Y	—	<b>31-4803-RFX</b>	2	

\* recognized under the component program of U.L, Inc. ▲ distributor stocked ‡ IBM 5252764

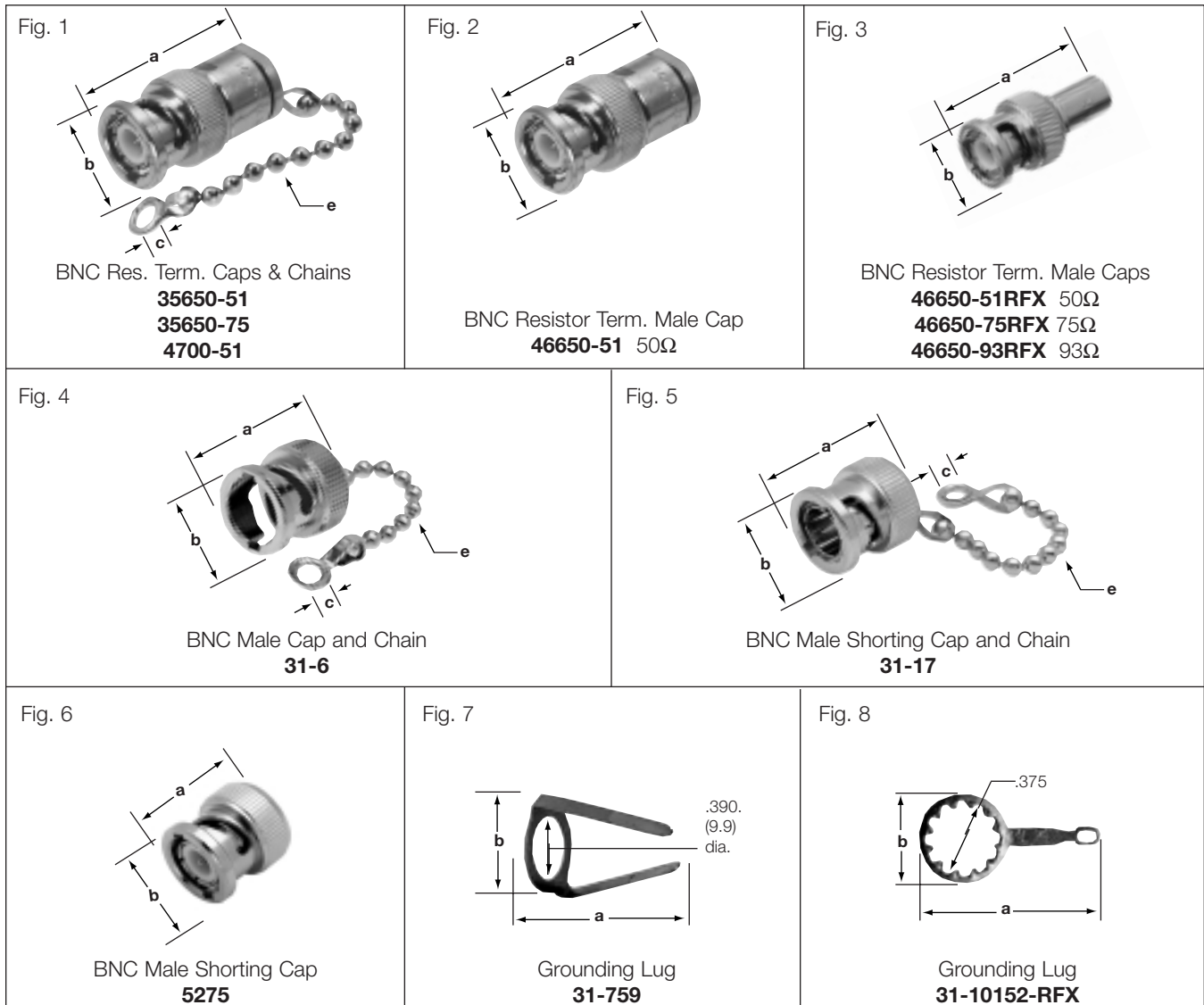

## BNC CAPS & ACCESSORIES

Description	Dimensions, inches (millimeters)				Notes		Military Number	Amphenol Number	Fig.	
	a	b	c	e	Pt.	Ins.				
Male Cap & Chain Resistor Terminated, 1% 1/2watt	50Ω	1.19(30.2)	.562(14.3)	.144(3.7)	3.50(88.9)	P1	D1	—	35650-51*	1
	75Ω					P1	D1	—	35650-75*	1
	51Ω					P1	D6	MX-554	4700-51**	1
Male Cap, Resistor Terminated, 1% 1 watt	51Ω	1.12(28.6)	.562(14.3)	—	—	P1	D1	—	46650-51*	2
Male Cap, Resistor Terminated, 1% 1 watt	50Ω	1.11(28.1)	.571(14.5)	—	—	P1	D23	—	46650-51RFX	3
	75Ω								46650-75RFX	3
	93Ω								46650-93RFX	3
Male Cap & Chain		.688(17.5)	.563(14.3)	.130(3.3)	2.25(57.2)	P3	—	CW-123/U	31-6*	4
Male Shorting Cap & Chain		.688(17.5)	.563(14.3)	.144(3.7)	2.50(63.5)	P1	—	CW-159/U	31-17*	5
Male Shorting Cap		.594(15.1)	.563(14.3)	—	—	P1	—	—	5275*	6
Pkg. of 25 Lugs Used Inside Panel on Front Mount Bulkhead Receptacles to Ground Cable Shield*		.961(24.4)	.578(14.7)	—	—	P3	—	(IBM 2245373)	31-759*	7
Pkg. of 25 Lugs Used Inside Panel on Front Mount Bulkhead Receptacles for Ground Wire to Circuit		1.156(29.4)	.578(14.7)	—	—	P8	—	—	31-10152-RFX*	8

■ IBM 3110787 \* recognized under the component program of U.L., Inc. ▲ distributor stocked

## Description

To meet the need for higher performance, impedance matched cable interconnections, Amphenol offers a full line of 75 ohm BNC connectors. These connectors can be used in a variety of applications where true 75 ohm performance is needed to insure lower signal distortion.



## Features/Benefits

Designed for the most popular 75 ohm cables used in broadcast and CATV applications as well as for plenum cables and others — these connectors feature crimp-crimp cable affixment for quick and reliable installation.

Two distinct types of 75Ω BNCs are available. Both types mate with each other and with 50Ω BNCs.

- Type 1 is designated 75Ω BNC-T1 and provides constant 75Ω performance with low VSWR DC to 4 GHz.
- Type 2 is designated 75Ω BNC-T2 and is usable with low reflection DC to 1 GHz. For applications above 1 GHz, Type 1 is recommended.

## Applications

- Broadcast
- Satellite TV Earth Stations
- Telecommunications
- LAN
- Test and Measurement
- Security Transmission Systems
- Telecom
- Computer Networks
- HDTV

## 75 ohm

75 ohm Connectors	123
BNC Plugs and Jacks	125-132
Adapters	133-134

# BNC 75 ohm Specifications

## ELECTRICAL

Impedance	75 ohms nominal
Frequency range	0-4 GHz
Voltage rating	500 volts rms
Dielectric withstanding voltage	1,500 volts rms.
Insulation resistance	5,000 megohms min.
VSWR	Type 1: 1.5 + 0.1 f(GHz) DC to 4 GHz Type 2: 1.00 + 0.25 f(GHz) DC to 1 GHz

\* These characteristics are typical and may not apply to all connectors.

## MATERIAL

Body, coupling sleeve, male contact	Brass
Female contact	Beryllium copper or phosphor bronze
Crimp ferrule	Copper alloy
Plating	Contacts: gold Other metal parts: Nickel

## MECHANICAL

Mating	2-stud bayonet lock
Cable affixment	Crimp-Crimp

## ENVIRONMENTAL

Temperature range	TFE insulators: - 65°C to + 165°C Copolymer of Styrene: - 55°C to + 85°C
Weatherproof	Clamps with clamp gaskets. Crimps with heat-shrink tubing.
Hermetic seals	Pass helium leak test of 2 X 10 <sup>-8</sup> cc/sec
Shock	MIL-Std. 202 method 202
Vibration	MIL-Std. 202 method 204 (test cond. D)
Moisture resistance	MIL-Std. 202 method 106
Corrosion	MIL-Std. 202 method 101 (test cond. B)
Temperature cycling	MIL-Std. 202 method 102 (test cond. D)
Altitude	MIL-Std. 202 method 105 (test cond. C)

## PLUG

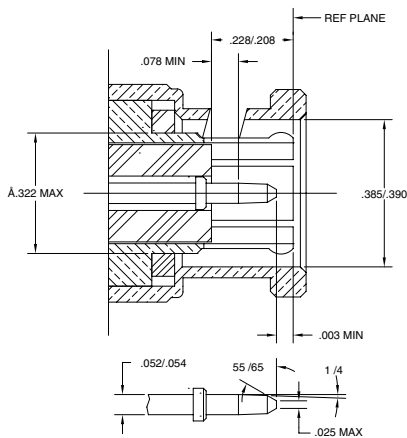

## JACK

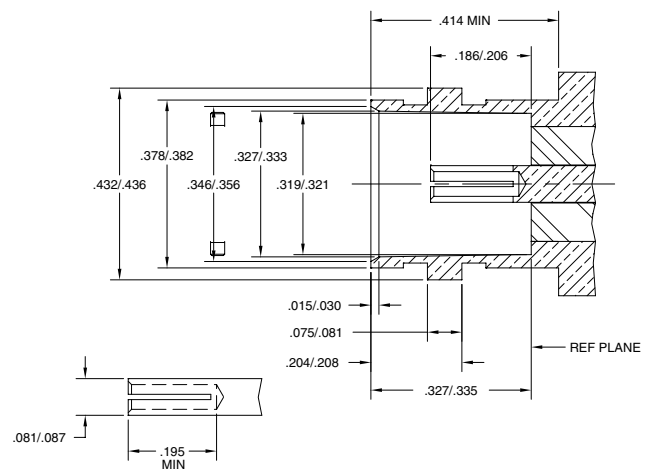
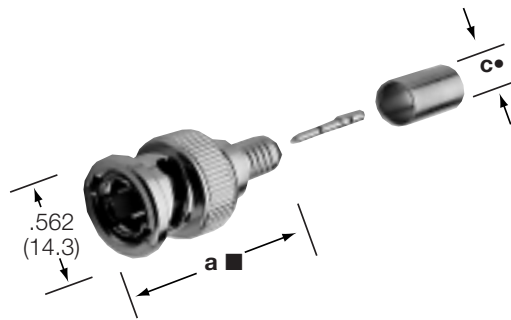

Fig. 1



75Ω BNC Crimp Plugs

<b>31-70000</b>	<b>31-70222</b>	<b>31-71008</b>	<b>31-71013-1000</b>
<b>31-70000-1000</b>	<b>31-70234</b>	<b>31-71008-1000</b>	<b>31-71032</b>
<b>31-70008</b>	<b>31-70235</b>	<b>31-71008-2000</b>	<b>31-71033</b>
<b>31-70008-1000</b>	<b>31-70236</b>	<b>31-71008-1RFX</b>	<b>31-71034</b>
<b>31-70008-3000</b>	<b>31-70237</b>	<b>31-71008-RFX</b>	<b>31-71035</b>
<b>31-70013</b>	<b>31-70238</b>	<b>31-71013</b>	<b>31-71064</b>
<b>31-70013-1000</b>	<b>31-71000-RFX</b>	<b>31-71013-RFX</b>	<b>31-71065</b>
			<b>31-71066</b>

## 75Ω BNC PLUGS AND ANGLE PLUGS

Cable RG-/U	Connector Configuration	Cable Attachment		Dimensions, inches (millimeters)			Notes			75Ω Type	Amphenol Number	Fig.
		Outer	Inner	a ■	c •	d	CAI	Pit.	Ins.			
RG-6 Type .295" O.D. max. Belden 9248, 1694A (Single Shield)	Plug	Crimp	Crimp	1.35(34.3)	.300(7.6)	—	C31	P15	D1	T1	<a href="#">31-70000</a> ☆	1 ▲
	Plug	Crimp	Crimp	1.21(30.7)	.300(7.6)	—	C32	P7	D26	T2	<a href="#">31-71000-RFX</a> ☆	1 ▲
	Plug	Crimp	Crimp	1.25(31.8)	.300(7.6)	—	C31	P15	D1	T1	<a href="#">31-70000-1000</a>	1 ▲
	Plug	Crimp	Crimp	1.21(30.7)	.300(7.6)	—	C32	P15	D1	T2	<a href="#">31-71064</a>	1 ▲
59, 62 Belden 8241, 8263, 8279, 9209	Plug	Crimp	Crimp	1.25(31.7)	.261(6.6)	—	C31	P16	D1	T1	<a href="#">31-70008</a>	1 ▲
	Plug	Crimp	Crimp	1.12(28.6)	.261(6.6)	—	C32	P15	D1	T2	<a href="#">31-71008</a>	1 ▲
	Plug	Crimp	Crimp	1.17(29.8)	.260(6.6)	—	C32	P7	D26	T2	<a href="#">31-71008-RFX</a>	1 ▲
59 (20GA CC) Belden 1426A, 1505A 9100, 9278	Plug	Crimp	Crimp	1.25(31.8)	.261(6.6)	—	C31	P15	D1	T1	<a href="#">31-70008-3000</a>	1 ▲
	Plug	Crimp	Crimp	1.12(28.5)	.261(6.6)	—	C32	P15	D1	T2	<a href="#">31-71008-1000</a>	1 ▲
	Plug	Crimp	Crimp	1.17(29.8)	.261(6.6)	—	C32	P7	D26	T2	<a href="#">31-71008-1RFX</a>	1 ▲
Plenum 59, Belden 88241 82259, 89259	Plug	Crimp	Crimp	1.11(28.2)	.220(5.6)	—	C32	P15	D1	T2	<a href="#">31-71008-2000</a>	1 ▲
Plenum 59 (20GA CC) Belden 82108	Plug	Crimp	Crimp	1.11(28.2)	.220(5.6)	—	C32	P15	D1	T2	<a href="#">31-71035</a>	1 ▲
DbI Shield 59 (20GA CC) 179, 187	Plug	Crimp	Crimp	1.36(34.5)	.334(8.5)	—	C31	P15	D1	T1	<a href="#">31-70222</a>	1 ▲
DbI. Br. 179	Plug	Crimp	Crimp	1.33(33.5)	.120(3.0)	—	C31	P15	D1	T1	<a href="#">31-70013</a>	1 ▲
	Plug	Crimp	Crimp	1.19(30.2)	.120(3.0)	—	C32	P15	D1	T2	<a href="#">31-71013</a>	1 ▲
	Plug	Crimp	Crimp	1.19(30.2)	.106(2.7)	—	C32	P17	D23	T2	<a href="#">31-71013-RFX</a>	1 ▲
ATT 728B, Belden 9231	Plug	Crimp	Crimp	1.25(31.7)	.175(4.4)	—	C31	P15	D1	T1	<a href="#">31-70013-1000</a>	1 ▲
	Plug	Crimp	Crimp	1.11(28.2)	.175(4.4)	—	C32	P15	D1	T2	<a href="#">31-71013-1000</a>	1 ▲
ATT 734A	Plug	Crimp	Crimp	1.36(34.5)	.342(8.7)	—	C31	P16	D1	T1	<a href="#">31-70022</a>	1 ▲
Belden 8218	Plug	Crimp	Crimp	1.25(31.7)	.261(6.6)	—	C31	P15	D1	T1	<a href="#">31-70008-1000</a>	1 ▲
Belden 8281, 88281	Plug	Crimp	Crimp	1.11 (28.2)	.175(4.4)	—	C32	P15	D1	T2	<a href="#">31-71033</a>	1 ▲
Belden 89248, (Plenum)	Plug	Crimp	Crimp	1.21 (30.7)	.342(8.7)	—	C32	P15	D1	T2	<a href="#">31-71032</a>	1 ▲
Belden 9290, 1152A (Double Shield)	Plug	Crimp	Crimp	1.35 (34.3)	.250 (6.4)	—	C31	P15	D1	T1	<a href="#">31-70000</a> ☆	1 ▲
Belden 89292	Plug	Crimp	Crimp	1.21 (30.7)	.314(8.0)	—	C32	P7	D26	T2	<a href="#">31-71000-RFX</a> ☆	1 ▲
Quad 59 Headend Cable Belden 1694	Plug	Crimp	Crimp	1.21 (30.7)	.314(8.0)	—	C32	P15	D1	T2	<a href="#">31-71065</a>	1 ▲
Belden 8218	Plug	Crimp	Crimp	1.62 (41.1)	.418(10.6)	*	C32	P15	D1	T2	<a href="#">31-71034</a>	1 ▲
Belden 8281	Plug	Crimp	Crimp	1.12 (28.6)	.287(7.3)	—	C32	P15	D1	T2	<a href="#">31-71066</a>	1 ▲
Belden 734A	Plug	Crimp	Crimp	1.00(25.4)	.571(14.5)	.358(9.1)	C26b	P7	D1	T1	<a href="#">31-70234</a>	1
Belden 735A	Plug	Crimp	Crimp	1.00(25.4)	.571(14.5)	.374(9.5)	C26b	P7	D1	T1	<a href="#">31-70235</a>	1
Belden 8218	Plug	Crimp	Crimp	1.00(25.4)	.571(14.5)	.201(5.1)	C26b	P7	D1	T1	<a href="#">31-70236</a>	1
Belden 734A	Plug	Crimp	Crimp	1.00(25.4)	.571(14.5)	.295(7.5)	C26b	P7	D1	T1	<a href="#">31-70237</a>	1
Belden 735A	Plug	Crimp	Crimp	1.00(25.4)	.571(14.5)	.213(5.4)	C26b	P7	D1	T1	<a href="#">31-70238</a>	1

• accommodates cable diameter ■ includes outer ferrule ☆ supplied with two crimp ferrules ▲ Distributor Stocked \* OD = .590(15.0)

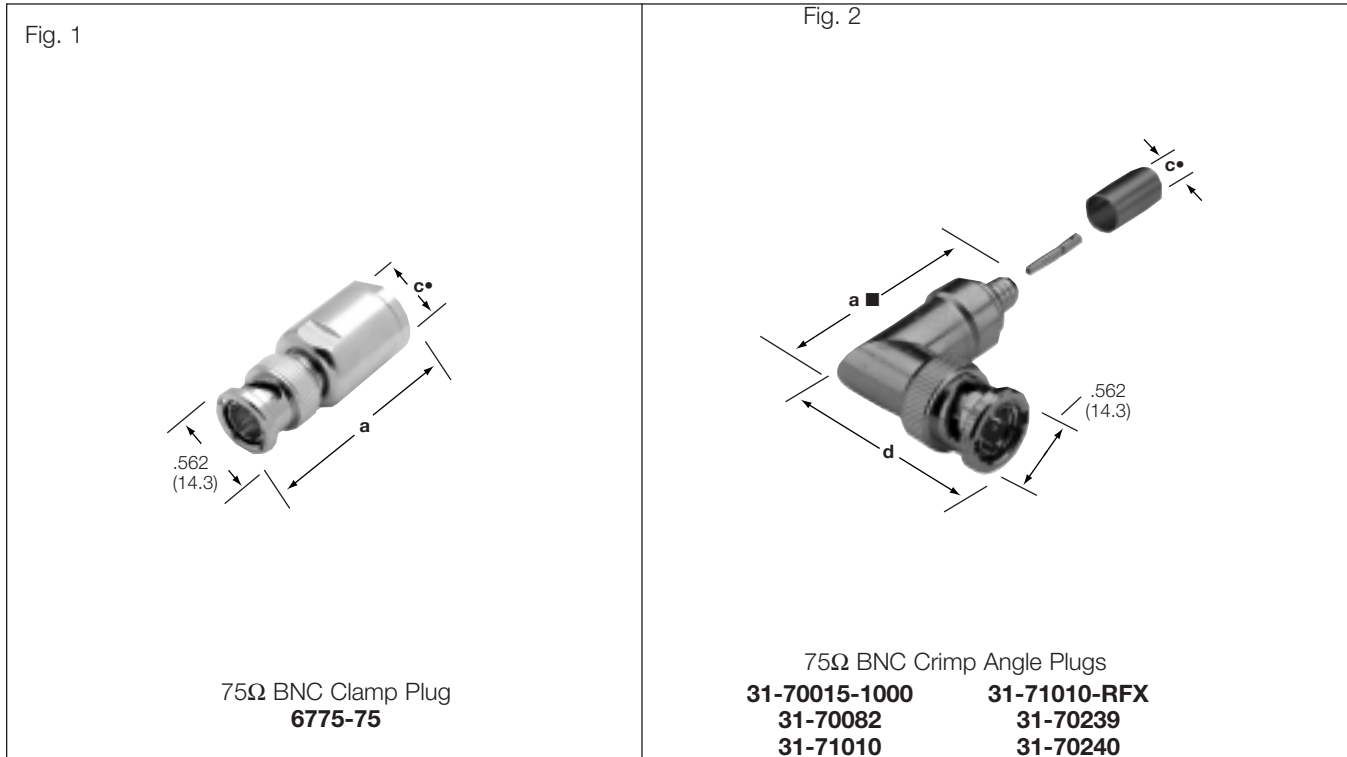

## 75Ω BNC PLUGS AND ANGLE PLUGS

Cable RG-/U	Connector Configuration	Cable Attachment		Dimensions, inches (millimeters)			Notes			75Ω Type	Amphenol Number	Fig.
		Outer	Inner	a ■	c •	d	CAI	Pit.	Ins.			
11	Plug	Clamp	Solder	1.75(44.4)	.443(11.2)	—	C25	P1	D1	T2	6775-75	1
59, 62 Belden 8241, 8263, 8279, 9209	Angle Plug	Crimp	Crimp	1.66(42.2)	.261(6.6)	1.24(31.5)	C32	P15	D1	T2	31-71010	2
	Angle Plug	Crimp	Crimp	1.66(42.2)	.260(6.6)	1.07(27.3)	C32	P7	D23	T2	31-71010-RFX	2
ATT 735A	Angle Plug	Crimp	Solder	1.09(27.7)	.158(4.0)	.894(22.7)	C31	P15	D1	T1	31-70082	2
ATT 19224-L2	Angle Plug	Crimp	Crimp	1.63(41.4)	.175(4.4)	1.24(31.5)	C31	P16	D1	T1	31-70015-1000	2
AT&T 734A†	Angle Plug	Crimp	Crimp	.571(14.5)	.295(7.5)	1.36(34.5)	C31	P7	D1	T1	31-70239	2
AT&T 735A†	Angle Plug	Crimp	Crimp	.571(14.5)	.295(7.5)	1.36(34.5)	C31	P7	D1	T1	31-70240	2

• accommodates cable diameter ■ includes outer ferrule ☆ supplied with two crimp ferrules ▲ Distributor Stocked ※ OD = .590(15.0) † Low Cost



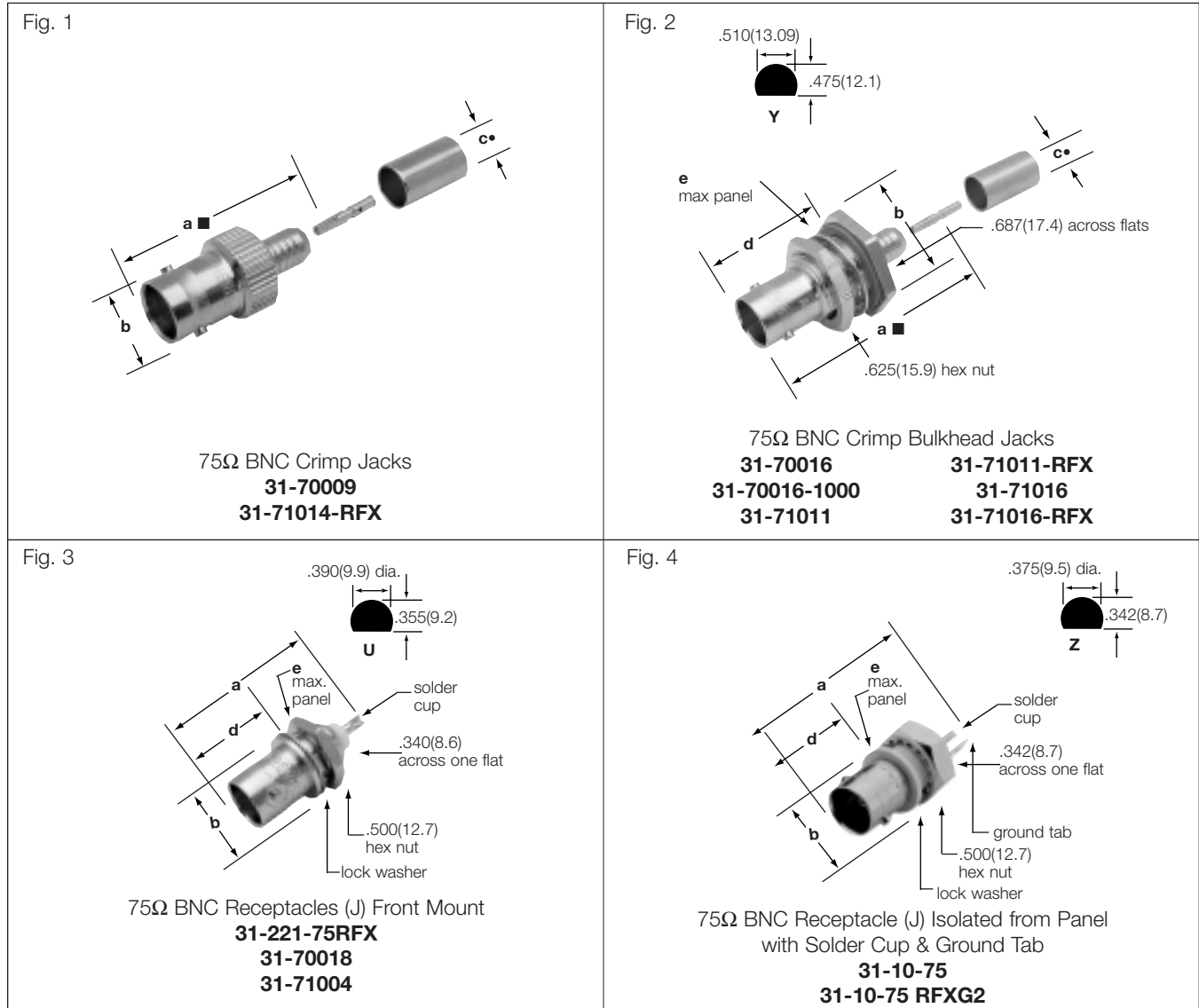

## 75Ω BNC JACKS & RECEPTACLES

Cable RG/U	Connector Type	Dimensions, inches (millimeters)					Notes			Mtg. Hole	75Ω Type	Amphenol Number	Fig.
		a ■	b	c ●	d	e	CAI	Pit.	Ins.				
59, Belden	Jack	1.18(30.0)	.510(12.9)	.261(6.6)	—	—	C31	P17	D1	—	T1	<b>31-70009</b>	1
8241, 8263	Bulkh. Jack	1.41(35.7)	.795(20.2)dia	.261(6.6)	.812(20.6)	.250(6.4)	C32	P15	D1	Y	T2	<b>31-71011</b>	2
59, 62, 140, 210	Bulkh. Jack	1.38(35.1)	.687(17.5)	.260(6.6)	.710(18.0)	.138(3.5)	C32	P7	D23	Y	T2	<b>31-71011-RFX</b>	2
179, 187	Jack	1.37(35.0)	.435(11.0)	.106(2.7)	—	—	C32	P7	D23	—	T2	<b>31-71014-RFX</b>	1
	Bulkh. Jack	1.48(37.7)	.687(17.4)hex	.120(3.0)	.812(20.6)	.250(6.4)	C31	P17	D1	Y	T1	<b>31-70016</b>	2
		1.41(35.7)	.795(20.2)dia	.120(3.0)	.812(20.6)	.250(6.4)	C32	P15	D1	Y	T2	<b>31-71016</b>	
1.43(36.4)	.687(17.4)hex	.106(2.7)	.710(18.0)	.138(3.5)	C32	P7	D23	Y	T2	<b>31-71016-RFX</b>	2		
Dbl. Br. 179 ATT 19224-L2	Bulkh. Jack	1.48(37.7)	.687(17.4)hex	.175(4.4)	.812(20.6)	.250(6.4)	C31	P15	D1	Y	T1	<b>31-70016-1000</b>	2
Bulkhead Receptacle (J) Front Mount		1.06(27.0)	.490(12.4)	—	.472(12.0)	.125(3.2)	—	P15	D1	U	T2	<b>31-71004</b>	3
		1.06(27.0)	.490(12.4)	—	.472(12.0)	.250(6.4)	—	P15	D1	U	T1	<b>31-70018</b>	
		1.05(26.7)	.500(12.7)	—	.475(12.1)	.138(3.5)	—	P7	D23	U	T2	<b>31-221-75RFX</b>	
Bulkhead Receptacle (J) Frnt Mt, Iso. from Panel		1.19(30.2)	.490(12.4)	—	.472(12.0)	.187(4.7)	—	P15	D12	Z	T2	<b>31-10-75</b>	4
Bulkhead Receptacle (J) Frnt Mt, Iso. from Panel		1.19(30.2)	.490(12.4)	—	.472(12.0)	.187(4.7)	—	P7	D12	Z	T2	<b>31-10-75-RFXG2</b>	4

■ Includes outer ferrule ● accommodates cable diameter ▲ Distributor Stocked

Fig. 1

Standard Height BNC Printed Circuit Board Right Angle Bulkhead Receptacles ☆

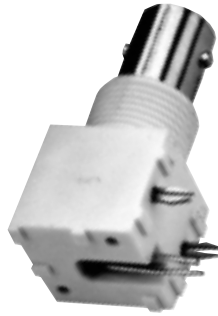
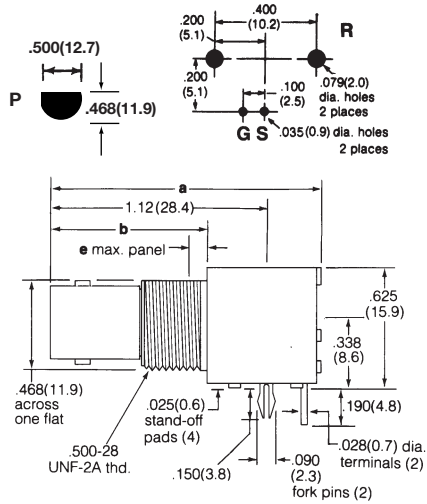

Isolated from Panel  
White Valox Housing  
**31-71047** (Round Pins)  
**31-71047-1010** (Fork Pins)



Isolated from Panel  
Black Valox Housing  
**31-71046** (Round Pins)  
**31-71046-1010** (Fork Pins)

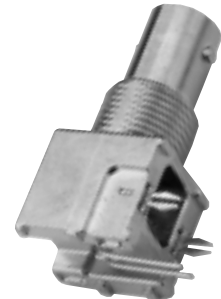

Metal Housing  
**31-71043** (Round Pins)  
**31-71043-1010▲**  
(Fork Pins)

Fig. 2

Low Profile BNC Printed Circuit Board Bulkhead Receptacles ☆

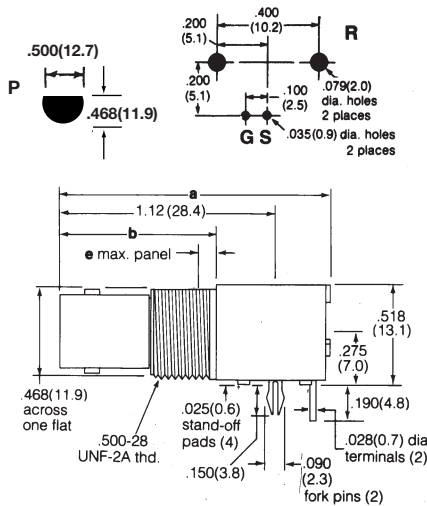

Isolated from Panel  
White Valox Housing  
**31-71052** (Round Pins)  
**31-71052-1010** (Fork Pins)  
**31-71052-10RFX**



Isolated from Panel  
Black Valox Housing  
**31-71053** (Round Pins)  
**31-71053-1010** (Fork Pins)



Metal Housing  
**31-71042** (Round Pins)

Fig. 3

Vertical BNC Printed Circuit Board Bulkhead Receptacles ☆

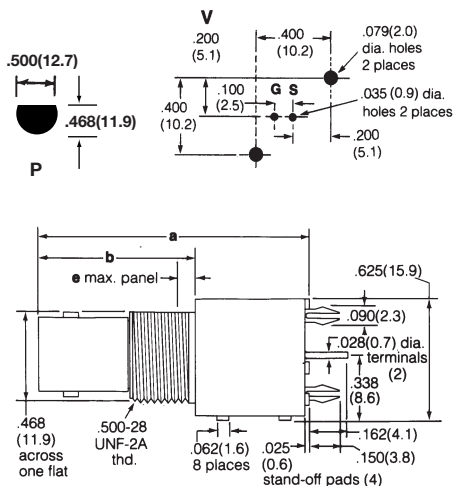

Isolated from Panel  
White Valox Housing  
**31-71058** (Round Pins)  
**31-71058-1010** (Fork Pins)







Isolated from Panel  
Black Valox Housing  
**31-71059** (Round Pins)  
**31-71059-1010** (Fork Pins)

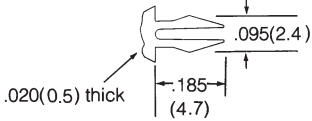

Metal Housing  
**31-71045** (Round Pins)  
**31-71045-1010**  
(Fork Pins)

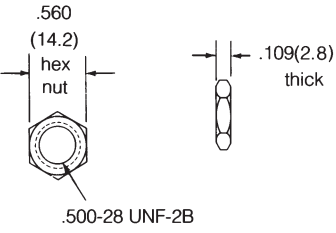
☆ Jam nuts and lockwashers sold separately. ▲ distributor stocked

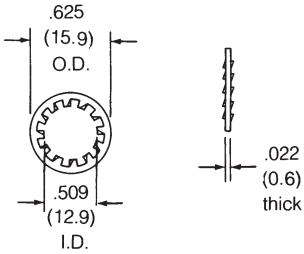
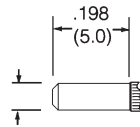
 <p>Fork Pin holds connectors rigidly to P.C. Board for high temperature and mass production assembly</p>	<p>Fig. 4</p>   <p>Pkg. of 100, Hex Nut for BNC Bulkhead PCB Receptacles <b>31-5652▲</b> Nickel Plated</p>	<p>Fig. 5</p>   <p>Pkg. of 100, Lockwasher for BNC PCB Bulkhead Receptacles <b>31-5653▲</b> Nickel Plated</p>
 <p>Round Pin (Standard)</p>		

## BNC PRINTED CIRCUIT BOARD BULKHEAD RECEPTACLES

Description	Terminal Type	Dimensions, inches (millimeters)			Notes		Mtg. Hole	Notes	Mtg. Pin Type	Imp	Amphenol Number	Fig.
		a	b	e	Plt.	Ins.						
Standard Height Printed Circuit Angle Bulkhead Receptacle (J)☆	Blunt Posts for Signal & Ground	1.40(35.6)	.810(20.6)	.250(6.4)	P26	D17	R/P	Iso. White Housing	Round	75Ω	<b>31-71047</b>	1
					P26	D17			Fork	75Ω	<b>31-71047-1010</b>	
					P26	D20	R/P	Iso. Black Housing	Round	75Ω	<b>31-71046</b>	
					P26	D20			Fork	75Ω	<b>31-71046-1010</b>	
					P26	D22	R/P	Metal Housing	Round	75Ω	<b>31-71043</b>	
P26	D22	Fork	75Ω	<b>31-71043-1010</b>								
Low Profile Printed Circuit Angle Bulkhead Receptacle (J)☆	Blunt Posts for Signal & Ground	1.40(35.6)	.810(20.6)	.250(6.4)	P26	D17	R/P	Iso. White Housing	Round	75Ω	<b>31-71052</b>	2
					P26	D17			Fork	75Ω	<b>31-71052-1010</b>	
					P26	D17	R/P	Iso. Black Housing	Fork	75Ω	<b>31-71052-10RFX</b>	
					P26	D20			Round	75Ω	<b>31-71053</b>	
					P26	D20	R/P	Metal Housing	Fork	75Ω	<b>31-71053-1010</b>	
P26	D22	Round	75Ω	<b>31-71042</b>								
Vertical Printed Circuit Bulkhead Receptacle (J)☆	Blunt Posts for Signal & Ground	1.40(35.6)	.810(20.6)	.250(6.4)	P26	D17	V/P	Iso. White Housing	Round	75Ω	<b>31-71058</b>	3
					P26	D17			Fork	75Ω	<b>31-71058-1010</b>	
					P26	D20	V/P	Iso. Black Housing	Round	75Ω	<b>31-71059</b>	
					P26	D20			Fork	75Ω	<b>31-71059-1010</b>	
					P26	D22	V/P	Metal Housing	Round	75Ω	<b>31-71045</b>	
P26	D22	Fork	75Ω	<b>31-71045-1010</b>								
Hex Nut for BNC Bulkhead PCB Receptacles, Package of 100 ea.					P3	—	—	Nickel Plated	—	—	<b>31-5652</b>	4
Lockwasher for BNC Bulkhead PCB Receptacles, Package of 100 ea.					P3	—	—	Nickel Plated	—	—	<b>31-5653</b>	5

☆ Jam nuts and lockwashers sold separately. See Figs. 4 & 5 ▲ distributor stocked

Fig. 1

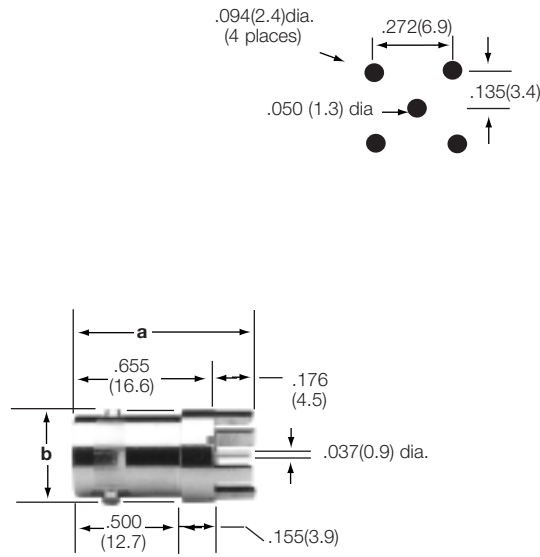

BNC PCB Receptacle (Jack)  
Post Terminal, 4 Legs  
.433" (11.0mm) Dia. Base  
**31-5329-72RFX**

**PRINTED CIRCUIT BOARD RECEPTACLE**

Description	Terminal Type	Dimensions, inches (mm)		Notes		Mtg. Hole	Amphenol Number	Fig.
		a	b	Plt.	Ins.			
PCB Receptacle, Vertical, 4 Legs .176(4.5) Long/ Post terminal .037(0.9)" Dia.	Blunt Post	.831(21.1)	.433(11.0) dia	P17	D25	F	<a href="#">31-5329-72RFX</a>	1 ▲

▲ distributor stocked

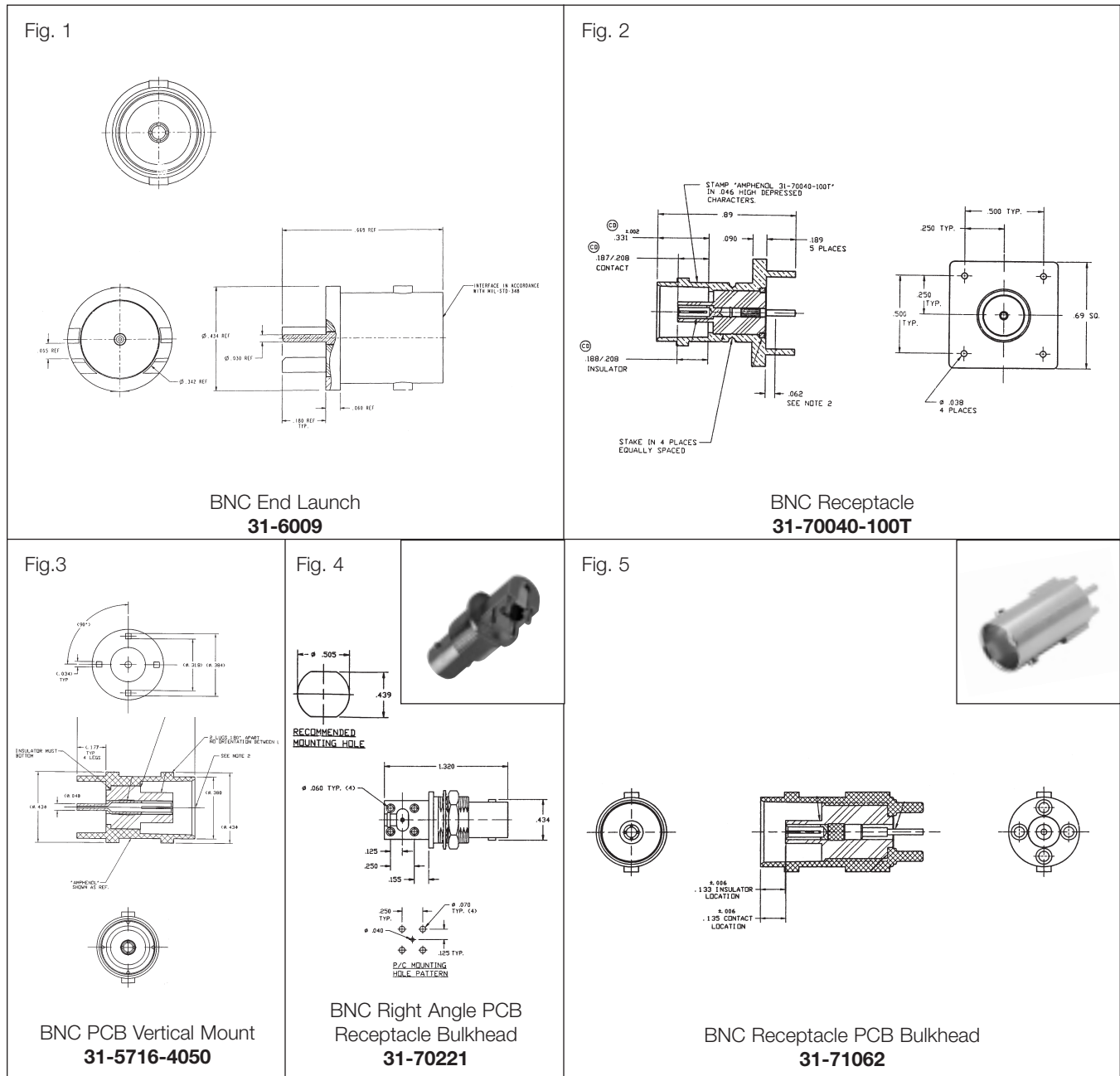

## 75Ω BNC JACKS

Description	Terminal Type	Dimensions, inches (millimeters)			Notes		Mtg. Hole	UG No.	75Ω	Amphenol Number	Fig.
		a	b	c	Pit.	Ins.					
PCB Vertical Mount	Blunt Post	.716(18.2)	.434(11.0)	.177(4.5)	P17	D1	—	—	T2	<a href="#">31-5716-4050</a>	3
End Launch Rec.	Blunt Post	.668(17.0)	.434(11.0)	.060(1.5)	P17	D1	—	—	T1	<a href="#">31-6009</a>	1
Receptacle	Blunt Post	.890(22.6)	.380(9.7)	.189(4.8)	P17	D1	—	—	T1	<a href="#">31-70040-100T</a>	2
Rt. Angle PCB Rec Bulkhead	Blunt Post	1.32(33.5)	.434(11.0)	.158(4.0)	P17	D1	—	—	T1	<a href="#">31-70221</a>	4
Rec. PCB Bulkhead	Blunt Post	.880(22.4)	.380(9.7)	.160(4.1)	P17	D1	—	—	T1	<a href="#">31-71062</a>	5

▲ distributor stocked

# BNC 75 ohm High Performance Beryllium Copper Outer Contacts

Amphenol®

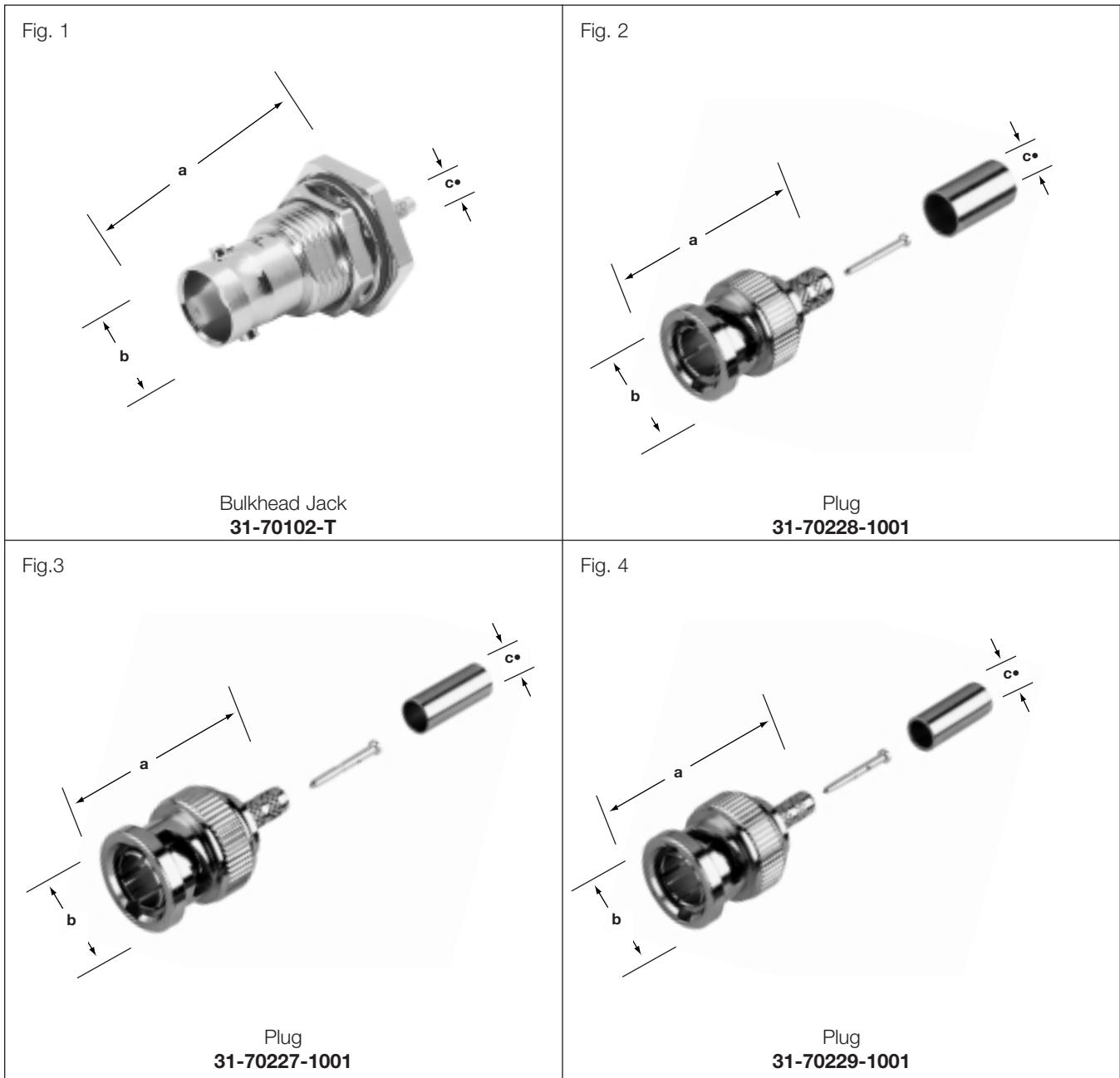

## HIGH PERFORMANCE

Description	Cable	Dimensions, inches (millimeters)			Notes		Mtg. Hole	UG No.	75Ω	Amphenol Number	Fig.
		a	b	c	Plt.	Ins.					
Bulkhead Jack	Rockwell 425-1129-000	1.417	.687	.128	P7	CA	—	—	T1	<a href="#">31-70102-T</a>	1
Plug	734A	1.20	.563	.226	P7	CA	—	—	T1	<a href="#">31-70228-1001</a>	2
Plug	L910	1.20	.563	.106	P7	CA	—	—	T1	<a href="#">31-70227-1001</a>	3
Plug	735A	1.20	.563	.141	P7	CA	—	—	T1	<a href="#">31-70229-1001</a>	4

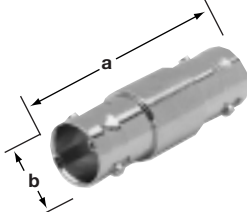
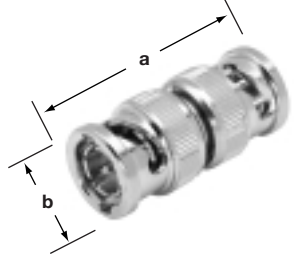
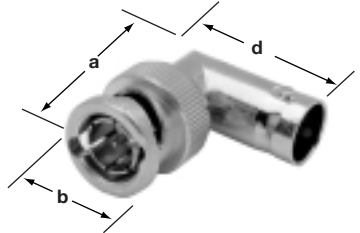
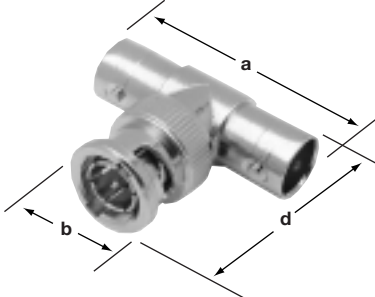
<p>Fig. 1</p>  <p>75Ω BNC Adapter (J/J) <b>31-219-75</b> <b>31-70019</b></p>	<p>Fig. 2</p>  <p>75Ω BNC Adapter (P/P) <b>31-218-75RFX</b></p>
<p>Fig.3</p>  <p>75Ω BNC Adapter (P/J) <b>31-9-75</b> <b>31-9-75-RFX</b></p>	<p>Fig. 4</p>  <p>75Ω BNC Tee Adapter (J/P/J) <b>31-70036</b></p>

BNC

## 75Ω BNC ADAPTERS

Description		Dimensions, inches (millimeters)			Notes		Mtg. Hole	UG No.	75Ω Type	Amphenol Number	Fig.
		a	b	d	Plt.	Ins.					
Straight	Jack-Jack	1.28(32.5)	.434(11.0)	—	P15	D1	—	—	T2	<a href="#">31-219-75</a>	1
Straight	Jack-Jack	1.40(35.6)	.434(11.0)	—	P17	D1	—	—	T1	<a href="#">31-70019</a>	1 ▲
Straight	Plug-Plug	1.33(33.7)	.571(14.5)	—	P15	D1	—	—	T2	<a href="#">31-218-75RFX</a>	2
Angle	Jack-Plug	1.02(25.9)	.562(14.3)	.405(10.3)	P15	D9	—	—	T2	<a href="#">31-9-75</a>	3 ▲
Tee	Jack-Plug-Jack	1.28(32.5)	.562(14.3)	1.04(26.3)	P15	D1	—	—	T1	<a href="#">31-70036</a>	4

▲ distributor stocked

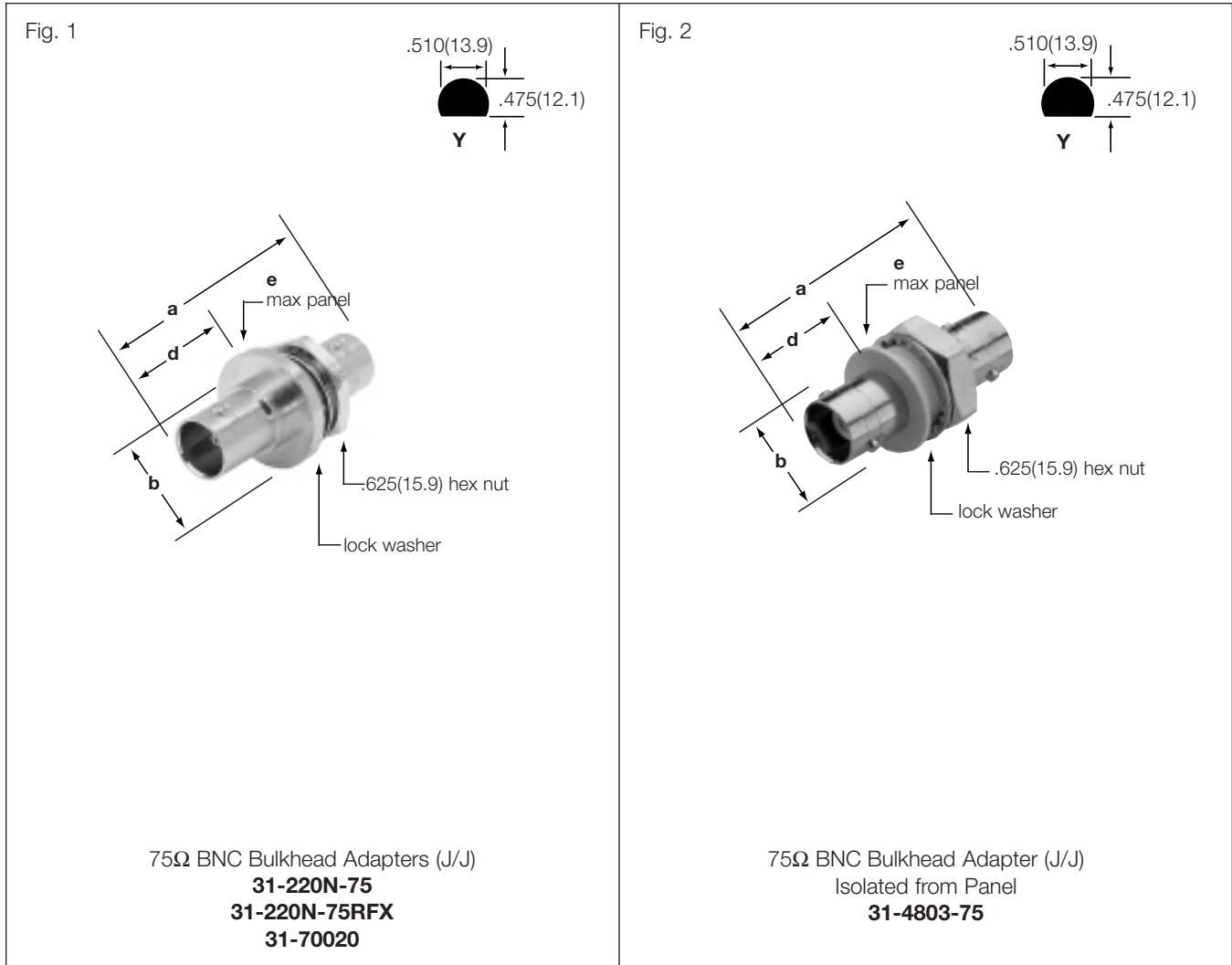

## 75Ω BNC BULKHEAD ADAPTERS

Description		Dimensions, inches (millimeters)				Notes		Mtg. Hole	UG No.	75Ω Type	Amphenol Number	Fig.
		a	b	d	e	Plt.	Ins.					
Gasketed	Jack-Jack	1.40(35.6)	.750(19.0)	.666(16.9)	.172(4.4)	P15	D1	Y	—	T1	<a href="#">31-70020</a>	1
Not Gasketed	Jack-Jack	1.28(32.5)	.750(19.0)	.492(12.5)	.216(5.5)	P7	D23	Y	—	T2	<a href="#">31-220N-75RFX</a>	1 ▲
Not Gasketed	Jack-Jack	1.40(35.6)	.800(20.3)	.664(16.8)	.181(4.6)	P17	D1	Y	—	T2	<a href="#">31-220N-75</a>	1
Isolated	Jack-Jack	1.28(32.5)	.625(15.9)	.460(11.7)	.190(4.8)	P17	D12	Y	—	T2	<a href="#">31-4803-75</a>	2 ▲

▲ distributor stocked





## Description

A new high performance line of LMR cable connectors. Advanced communication systems have placed stringent performance requirements on connectors. Amphenol has designed BNC, SMA and TNC connectors to exceed the standard requirements.

Only Amphenol brings you all three connectors designed for high performance LMR cable to insure you have the right product for that application. These connector series provide interconnect solutions inside and between instrument racks, between equipment rooms, antenna jumpers, and anywhere quality interconnections are required.

## Features/Benefits

- TNC versions are MIL-C-39012 compatible
- Weatherproof design
- Crimp-solder termination
- Tarnish-resistant Nickel plating
- Allows mating with all TNC connectors
- Allows use in inclement weather
- Ensures easy installation
- Provides corrosion resistance

## Applications

- AM and FM Broadcast
- CATV
- Cellular
- ESA Jumper
- ESMR
- HF Communications
- LMR
- Paging
- PCS
- Point-to-Point

---

## BNC/TNC for Cable

Specifications	136
BNC	137
TNC	138

---

## ELECTRICAL

Impedance	50 ohms
Frequency range	0-4 GHz 0-11 GHz.
Voltage rating	500 volts peak
Dielectric withstanding voltage	1,500 volts rms.
VSWR (0-4 GHz) Straight: Right Angle:	M39012 1.30 max M39012 1.35 max

NOTE: These characteristics are typical and may not apply to all connectors.

## MATERIAL

Center contacts	Male, Brass Gold plated Female BeCu or Phosphor Bronze Gold plated
Other metal parts	Brass Nickel finish silver plated.
Insulators	Teflon
Crimp ferrule	Copper

## ENVIRONMENTAL

Temperature range	Teflon insulators -65°C to + 165°C
Shock	Mil-STD-202 Method 202
Vibration	Mil-STD-202 Method 204 (test Cond. D)
Moisture resistance	Mil-STD-202 Method 106
Corrosion	Mil-STD-202 Method 101 (test Cond. B)
Interface diameter M39012	Mil-STD-348 Series meets or exceeds the requirements for BNC and TNC

## PLUG

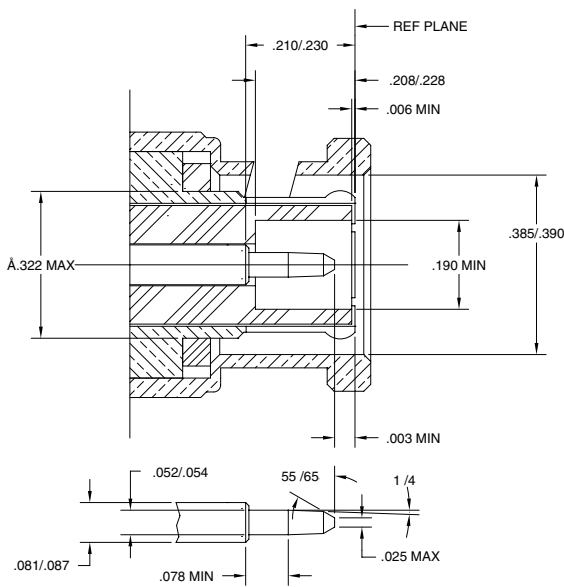

## JACK

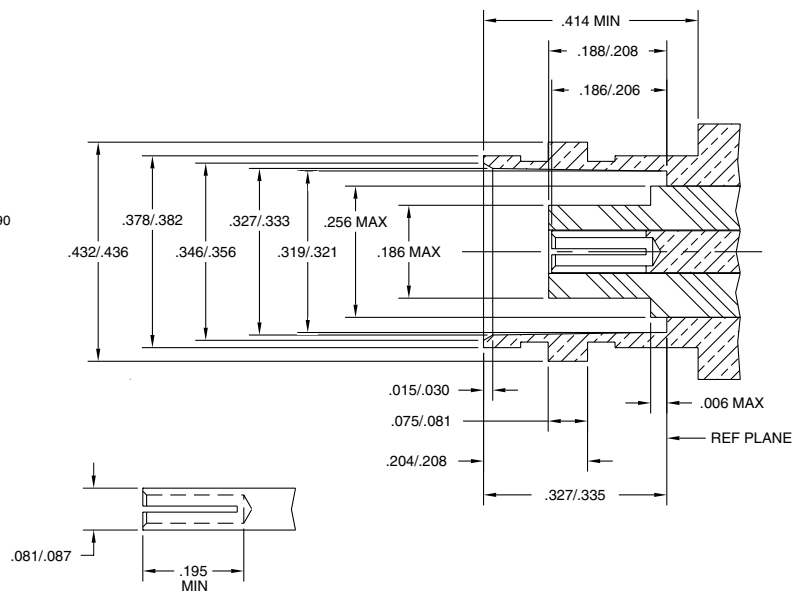

## PLUG

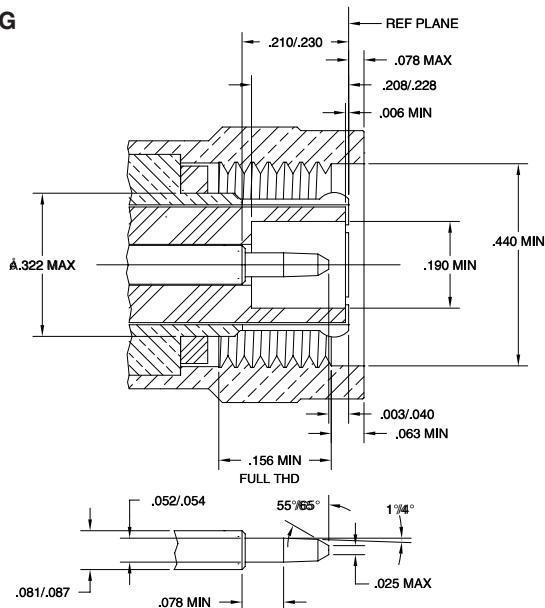

## JACK

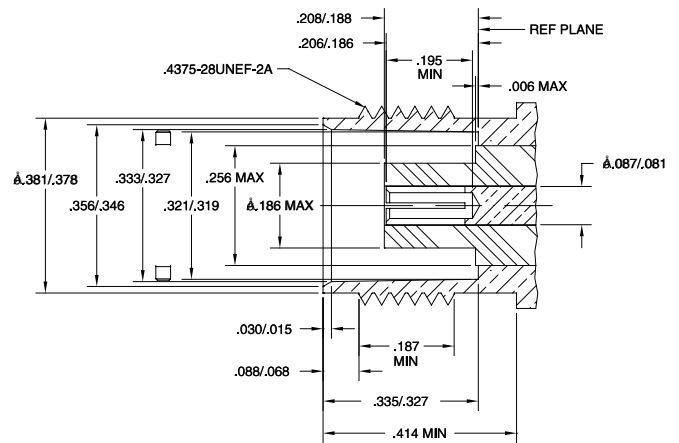

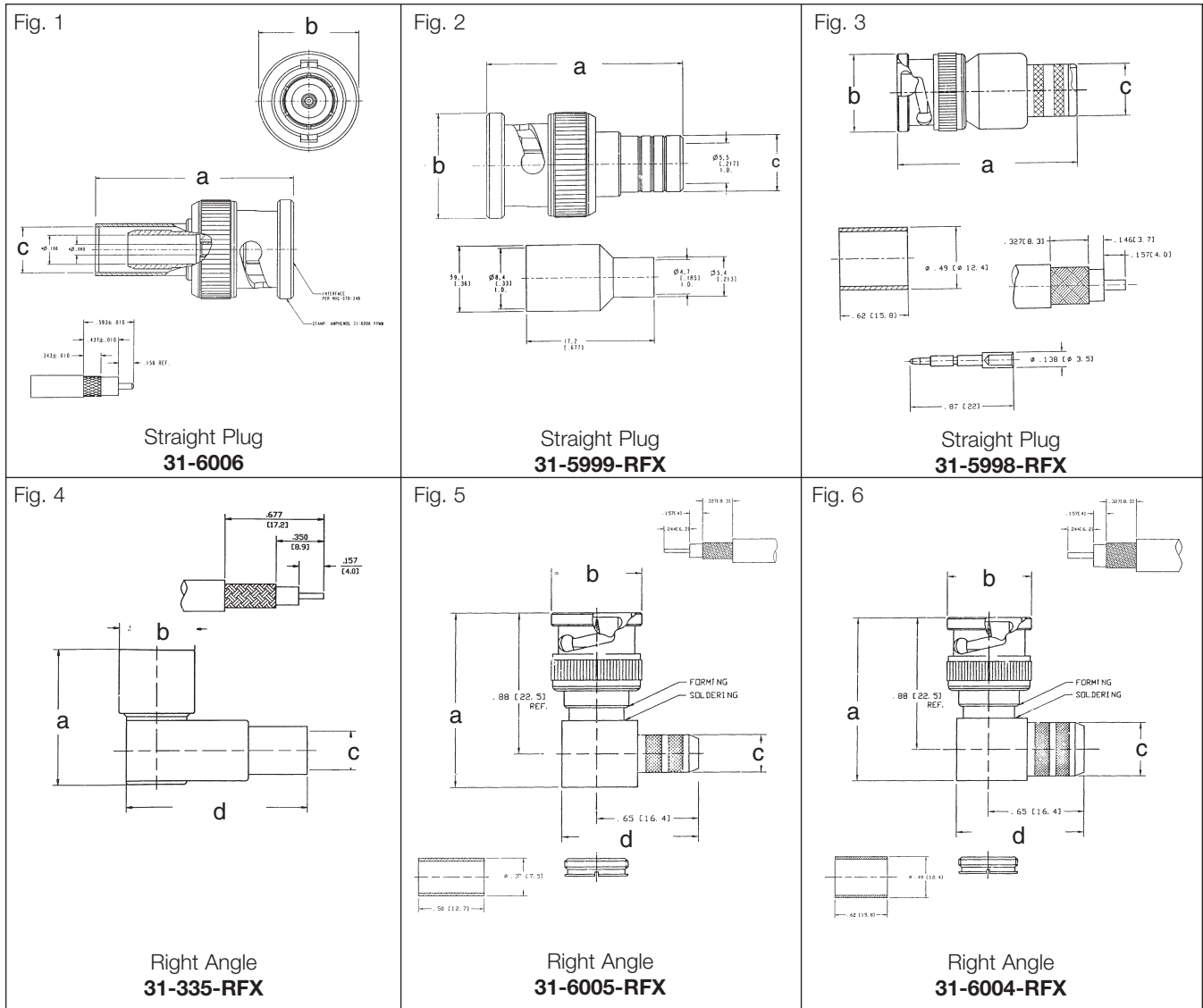

**BNC PLUG - Straight & Right Angle**

Style	Amphenol Cable	Times Cable	Belden Cable	a	b	c	d	CAI	Amphenol Part Number	Fig
Straight Plug	-	LMR200	RG 58	1.121	.563	.261	—	C36	<b>31-6006</b>	1
Straight Plug	TWB2401	LMR240	9258	1.039(26.4)	.563(14.3)	.303(7.7)	—	C36	<b>31-5999-RFX</b>	2
Straight Plug	TWB4001	LMR400	9913,9914	1.36(34.5)	.571(14.5)	.366(9.3)	—	C36	<b>31-5998-RFX</b>	3
Right Angle	-	LMR200	RG 58	1.07(21.3)	.571(14.5)	.210	.160(40.7)	C36	<b>31-335-RFX</b>	4
Right Angle	TWB2401	LMR240	9258	1.02(26)	.57(14.3)	.22(.56)	.86(21.9)	C36	<b>31-6005-RFX</b>	5
Right Angle	TWB4001	LMR400	9913, 9914	1.02(26)	.57(14.3)	.37(9.3)	.86(21.9)	C36	<b>31-6004-RFX</b>	6

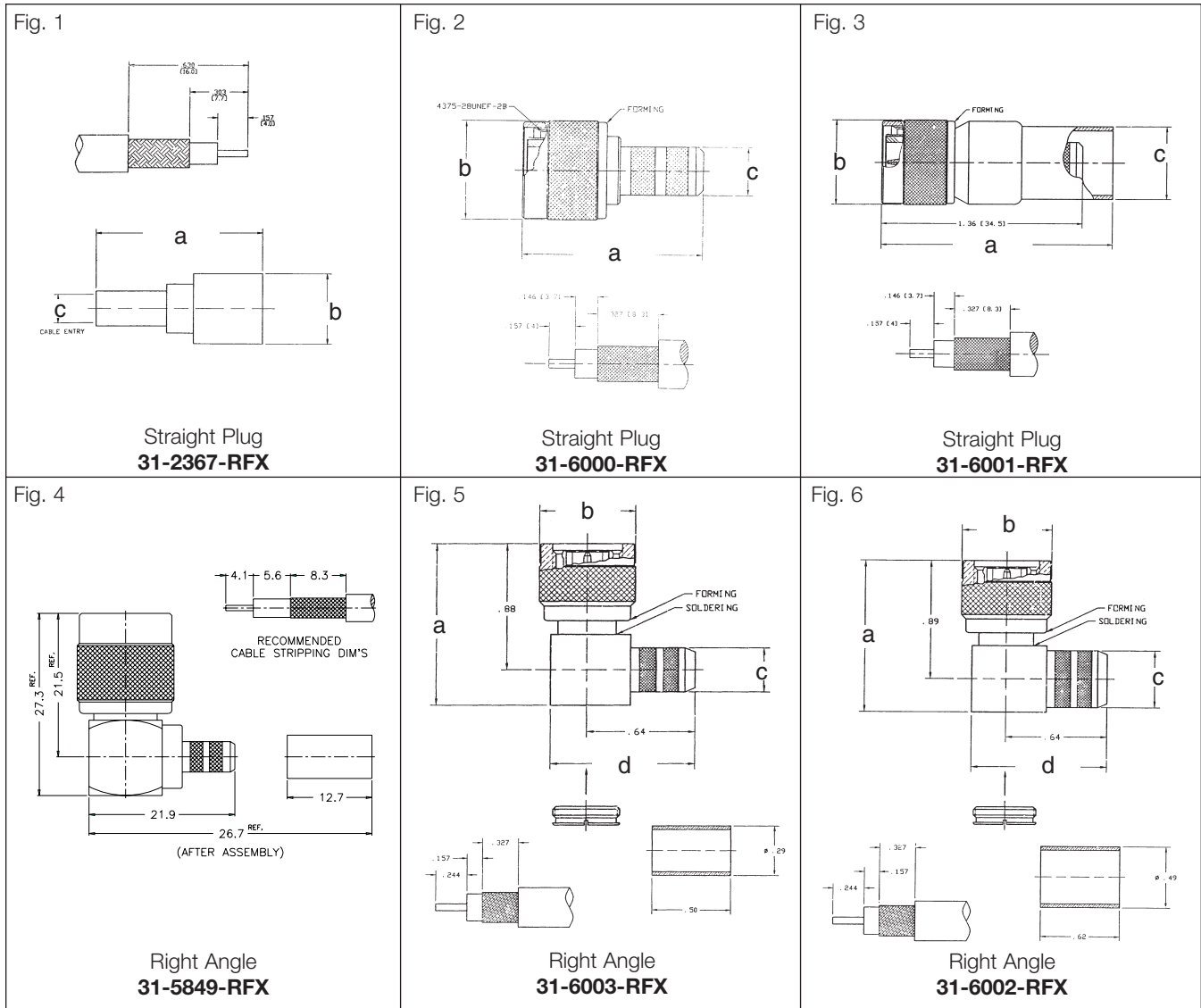

**TNC PLUG - Straight & Right Angle**

Style	Times Cable	Belden Cable	a	b	c	d	CAI	Amphenol Part Number	Fig
Straight Plug	LMR200	RG 58	1.17(29.8)	.571(14.5)	.210	—	C36	<a href="#">31-2367-RFX</a>	1
Straight Plug	LMR240	9258	.984(25.0)	.571(14.5)	.220(5.6)	—	C36	<a href="#">31-6000-RFX</a>	2
Straight Plug	LMR400	9913,9914	1.67(42.4)	.571(14.5)	.49(12.4)	—	C36	<a href="#">31-6001-RFX</a>	3
Right Angle	LMR200	RG 58	—	—	—	—	C36	<a href="#">31-5849-RFX</a>	4
Right Angle	LMR240	9258	1.10	.57	.220	.86	C36	<a href="#">31-6003-RFX</a>	5
Right Angle	LMR400	9913, 9914	1.10	.57	.37	.86	C36	<a href="#">31-6002-RFX</a>	6

**Description**

Developed in the late 1950's, TNC is a threaded version of the BNC. TNC stands for Threaded Neill Concelman and is named after Amphenol engineer Carl Concelman. This series features screw threads for mating. TNC are miniature, threaded weatherproof units with a constant 75 ohm impedance and operate from 0-11 GHz.

There are two families of TNC connectors:

- Standard
- Reverse Polarity

They are an ideal choice for use in cellular and mobile communications, and test and measurement equipment. They are also widely used in airframe, aerospace and radar applications where extreme vibration is a factor.

Cable connectors range from RG6 to RG179 and include LMR low loss cable.

**Features/Benefits**

- Threaded coupling interface ensures connector will not decouple in vibration-intensive applications.
- Many TNC connectors are recognized under the component program of Underwriter's Laboratories and have undergone stringent testing from an independent laboratory.
- Performance from 0-11 GHz operates in many applications.

**Applications**

- Antennas
- Automotive (Cell Phones)
- Base Stations
- Cable Assemblies
- Components
- Computer Networks/LANs
- Instrumentation
- Mil/Aero
- Radar
- Telecom



**TNC**

Specifications	140
Plugs	141-142
Angle Plugs & Jacks	143-144
PCB Receptacles	145-147

## ELECTRICAL

Impedance	50 ohms nominal
Frequency range	0-11 GHz
Voltage rating	500 volts peak
Dielectric withstanding voltage	1,500 volts rms.
VSWR	M39012 straight connectors: 1.3 max. 0-11 GHz M39012 right angle: 1.35 max. 0-11 GHz
Other (MIL-C-39012 cable connectors)	Contact resistance: center contact 1.5 milliohm outer contact 0.2 milliohm  Braid to body 0.1 milliohm  RF leakage: -60 dB minimum at 3 GHz Insertion loss: 0.18 dB at 9 GHz Insulation resistance: 5000 megohms (min.)

## MILITARY SPECIFICATIONS

MIL-C-39012	Where applicable
-------------	------------------

\* Amphenol TNC connectors are classified as weatherproof only when used in combination with other Amphenol TNC connectors.

## MECHANICAL

Mating	7/16 threaded coupling
Cable affixment (braid or jacket)	All crimps: hex braid crimp.  Clamps: screw-thread nut and braid clamp.
Cable affixment (center conductor)	Crimps: crimp or solder All others: solder only
Captivated contact	All crimps  Others: where specified.
Cable retention	Clamps: 20-50 lbs. Crimps: 20-100 lbs.

## MATERIAL

Center contacts	Male: Brass; female beryllium copper or phosphor bronze. Silver or gold plated
Other metal parts	Brass: Nickel finish except M39012 silver.
Insulators	TFE, Delrin
Clamp gaskets	Synthetic rubber, Silicone rubber
Crimp ferrule	Copper

## ENVIRONMENTAL

Temperature range	- 65°C to + 165°C
Weatherproof	Clamps with clamp gaskets. Other Crimps with heat-shrink tubing.
Hermetic seals	Pass helium leak test of $2 \times 10^{-8}$ cc/sec
Shock	MIL-Std. 202 method 202
Vibration	MIL-Std. 202 method 204 (test cond. D)
Moisture resistance	MIL-Std. 202 method 106
Corrosion	MIL-Std. 202 method 101 (test cond. B)
Temperature cycling	MIL-Std. 202 method 102 (test cond. D)
Altitude	MIL-Std. 202 method 105 (test cond. C)

\* These characteristics are typical and may not apply to all connectors.

## PLUG

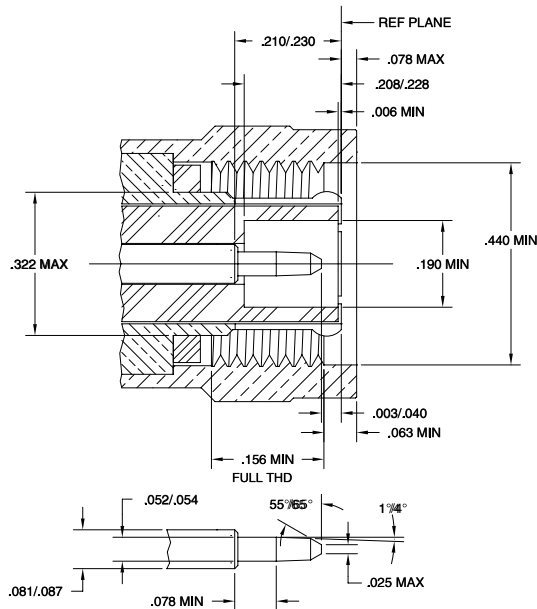

## JACK

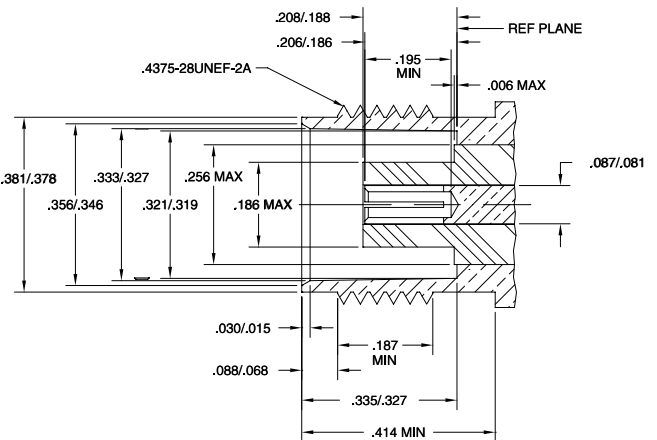

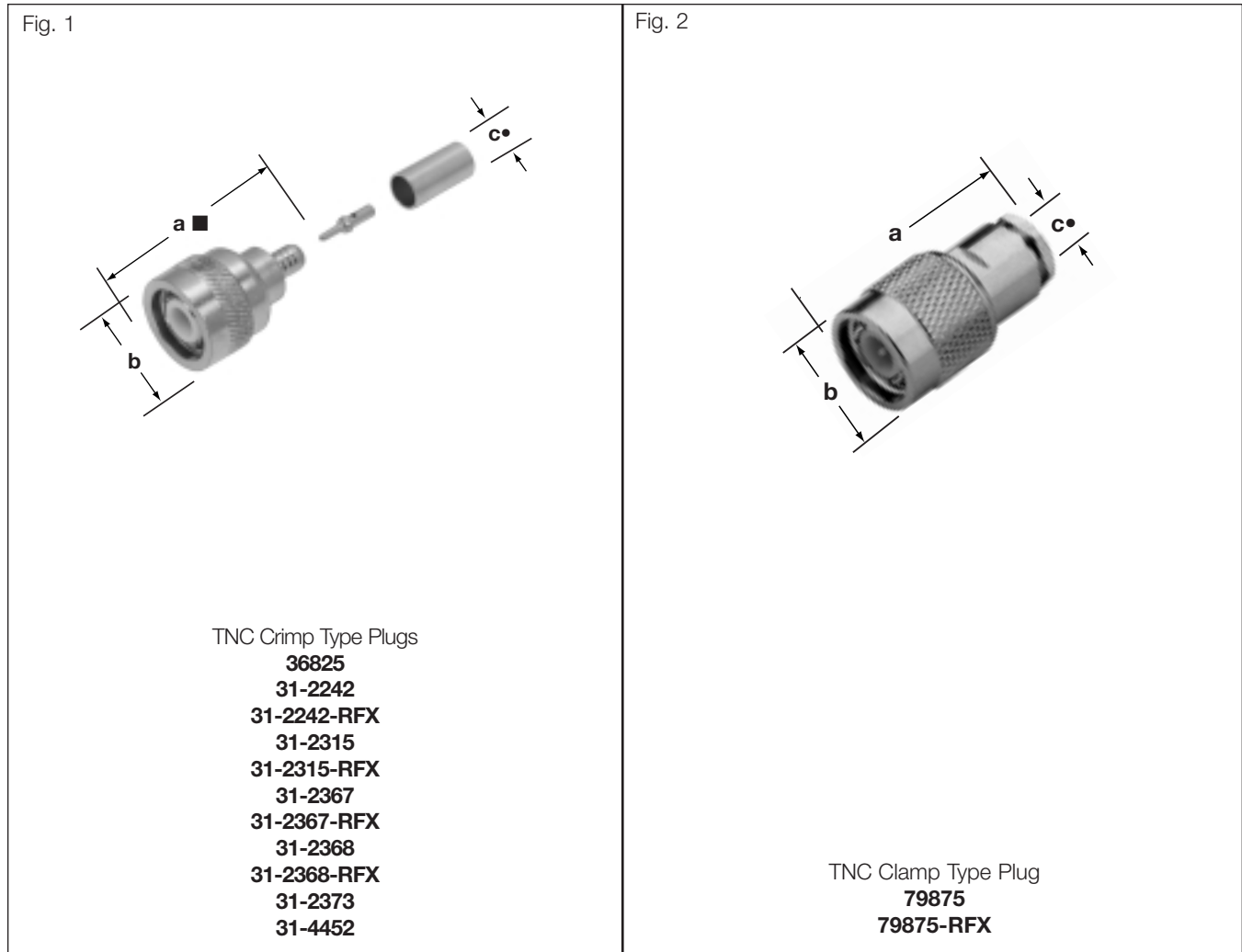

## TNC STRAIGHT PLUGS

Cable RG-/U	Conn. Type	Cable Attachment		Dimensions, inches (millimeters)			Notes			Military Number	Amphenol Number	Fig.
		Outer	Inner	a	b	c •	CAI	Plt.	Ins.			
58, 141	Plug	Crimp	Crimp	1.12(28.6) ■	.610(15.5)	.206(5.2)	C36	P15	D1	—	<b>36825</b>	1
	Plug	Crimp	Crimp	1.12(28.6) ■	.610(15.5)	.206(5.2)	C36	P15	D1	M23329/4-01,4-03	<b>31-2367</b>	1
	Plug	Crimp	Crimp	1.12(28.6) ■	.610(15.5)	.206(5.2)	C36	P7	D23	—	<b>31-2367-RFX</b>	1
59, 62	Plug	Crimp	Crimp	1.13(28.7) ■	.610(15.5)	.261(6.6)	C36	P15	D1	M23329/4-05	<b>31-2368</b>	1 ▲
142, 223	Plug	Crimp	Crimp	1.12(28.6) ■	.562(14.3)	.220(5.6)	C36	P15	D1	M23329/4-02,4-04	<b>31-2373</b>	1 ▲
142, 400	Plug	Crimp	Crimp	1.12(28.6) ■	.500(12.7)	.220(5.6)	C36	P34	D1	M39012/26-0503	<b>31-4452*</b>	1
179, 187	Plug	Crimp	Crimp	1.19(30.2) ■	.610(15.5)	.120(3.0)	C36	P7	D1	—	<b>31-2242</b>	1 ▲
174, 188	Plug	Crimp	Crimp	1.19(30.2) ■	.610(15.5)	.115(2.9)	C36	P7	D1	—	<b>31-2315</b>	1
174, 188, 316	Plug	Crimp	Crimp	1.19(30.2) ■	.517(13.1)	.106(2.7)	C36	P7	D23	—	<b>31-2315-RFX</b>	1
179, 187	Plug	Crimp	Crimp	1.19(30.2) ■	.517(13.1)	.106(2.7)	C36	P7	D23	—	<b>31-2242-RFX</b>	1
59, 62	Plug	Crimp	Crimp	1.17(29.7) ■	.517(13.1)	.260(6.6)	C36	P7	D23	—	<b>31-2368-RFX</b>	1
58, 142A	Plug	Clamp	Solder	1.07(27.1) ■	.827(21.0)	.212(5.4)	C36	P7	D23	—	<b>79875-RFX</b>	2
55, 58, 141, 142, 223, 400	Plug	Clamp	Solder	1.06(27.0)	.610(15.5)	.224(5.7)	C34	P1	D23	—	<b>79875*</b>	2

\* recognized under the component program of U.L., Inc. ▲ distributor stocked ■ includes outer ferrule

Fig. 1

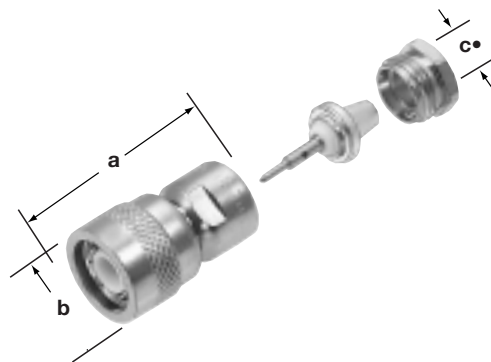

TNC QUICKTRIM® Plug  
31-5061

## TNC STRAIGHT PLUGS

Cable RG-/U	Conn. Type	Cable Attachment		Dimensions, inches (millimeters)			Notes			Military Number	Amphenol Number	Fig.
		Outer	Inner	a	b	c •	CAI	Plt.	Ins.			
59, 62	Plug	QUICKTRIM®		1.03(26.2)	.610(15.5)	.252(6.4)	C37	P15	D1	—	31-5061	1



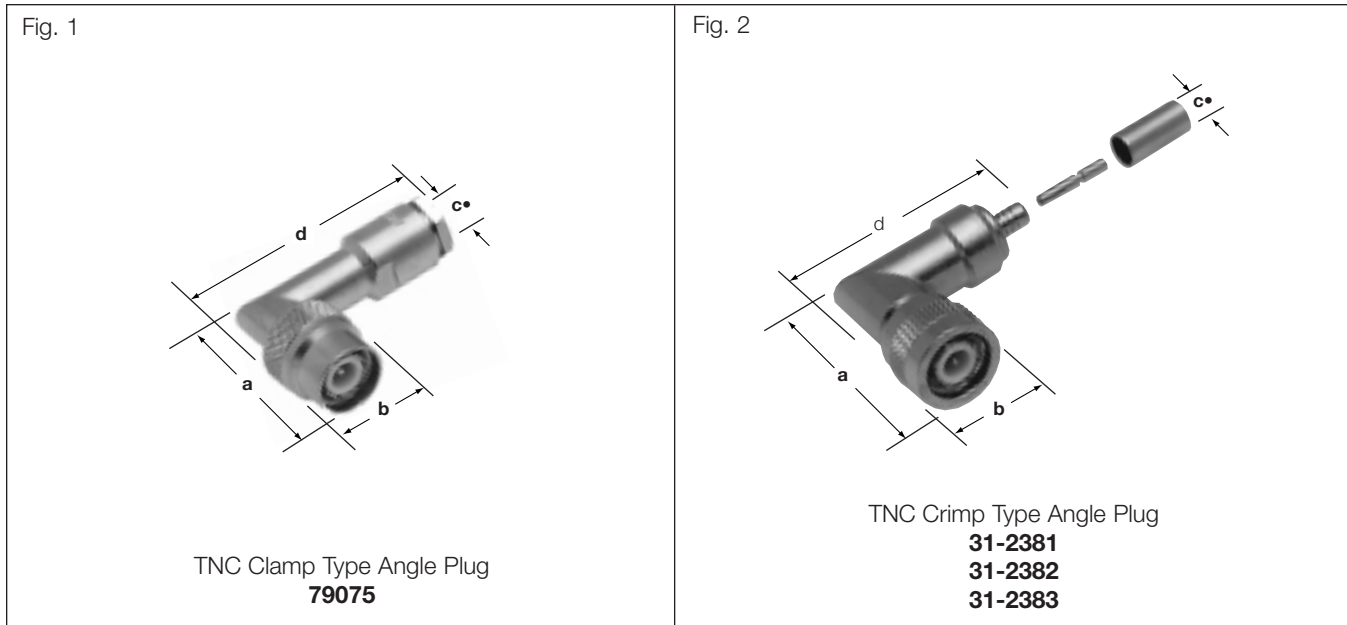

## TNC ANGLE PLUGS & JACKS

Cable RG-/U	Conn. Type	Cable Attachment		Dimensions, inches (millimeters)				Notes			Military Number	Amphenol Number	Fig.
		Outer	Inner	a	b	c •	d	CAI	Pit.	Ins.			
55, 58, 141 142, 223, 400	Angle Plug	Clamp	Solder	1.12(28.6)	.610(15.5)	.224(5.7)	1.58(40.1)	C34	P1	D1	—	79075 *	1
55, 142, 223, 400	Angle Plug	Crimp	Crimp	1.19(30.2)	.562(14.3)	.220(5.6)	1.58(40.1)■	C36	P17	D1	—	31-2381	2
58, 141	Angle Plug	Crimp	Crimp	1.19(30.2)	.562(14.3)	.206(5.2)	1.58(40.1)	C36	P17	D1	—	31-2382	2 ▲
62	Angle Plug	Crimp	Crimp	1.19(30.2)	.562(14.3)	.261(6.6)	1.58(40.1)	C36	P17	D1	—	31-2383	2

\* recognized under the component program of U.L., Inc. • accommodates cable diameter ■ includes outer ferrule ▲ distributor stocked

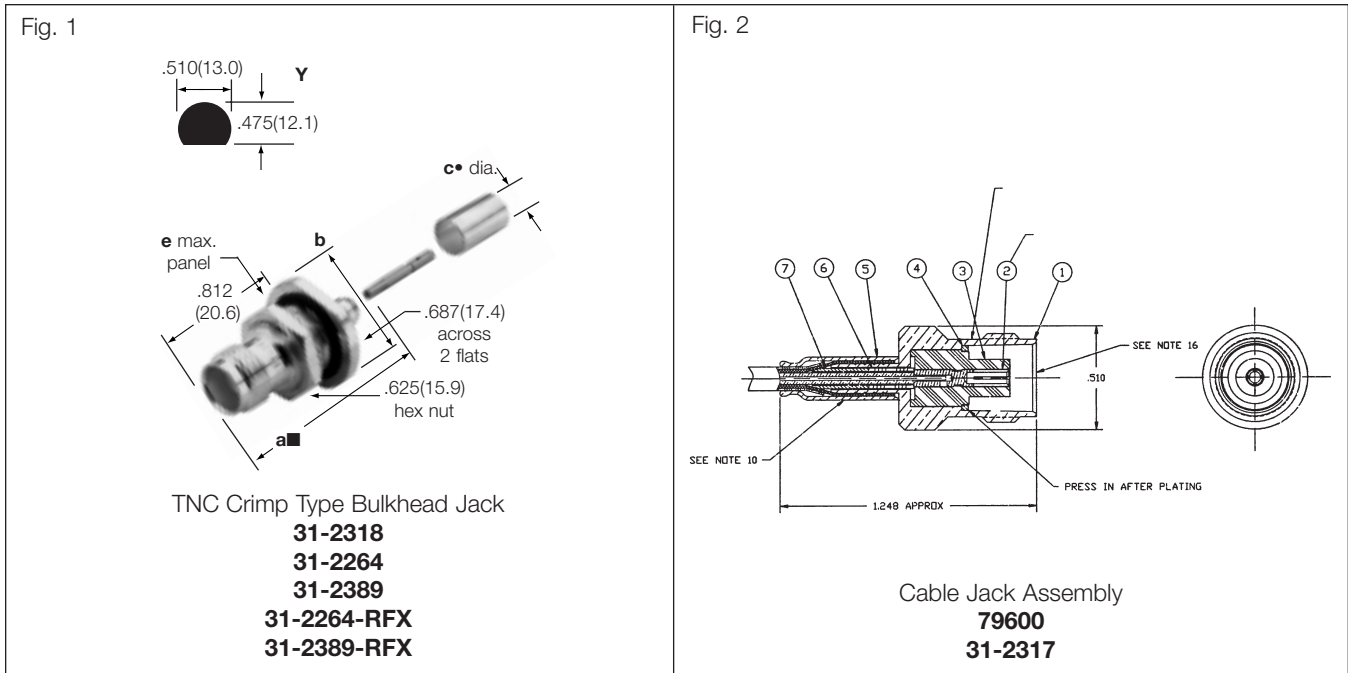

## TNC ANGLE JACKS

Cable RG-/U	Conn. Type	Cable Attachment		Dimensions, inches (millimeters)				Notes			Military Number	Amphenol Number	Fig.
		Outer	Inner	a	b	c •	e	CAI	Pit.	Ins.			
<b>59, 62, 140, 210</b>	Blkh. Jack	Crimp	Crimp	1.417	.687	.261	.160(4.1)	C36	P34	D1	—	<b>31-2264</b>	1
<b>58, 141A</b>	Blkh. Jack	Crimp	Crimp	1.407	.625	.206	.240(6.1)	C36	P15	D1	—	<b>31-2389</b>	1
<b>58, 141, 142</b>	Jack	Crimp	Crimp	1.38	.510	.115	.138(3.5)	C36	P15	D23	—	<b>31-2264-RFX</b>	1
<b>59, 62</b>	Blkh Jack	Crimp	Crimp	1.19	.470	.123	.138(3.5)	C36	P15	D23	—	<b>31-2389-RFX</b>	1
<b>174, 188, 316</b>	Bkhd Jack	Crimp	Crimp	1.31(33.3)*	.795(20.2)	.115(2.9)	.115(2.9)	C36	P15	D1	—	<b>31-2318 *</b>	1
<b>58</b>	Straight Cable Plugs	Clamp	Solder	1.25	.625	.562	—	C34	P17	D1	—	<b>79600</b>	2
<b>174, 188, 316</b>	Straight Cable Plug	Crimp	Crimp	1.248	.510	.261	—	C36	P15	D1	—	<b>31-2317</b>	2

\* Recognized under the component program of U.L., Inc.

▪ Includes outer ferrule

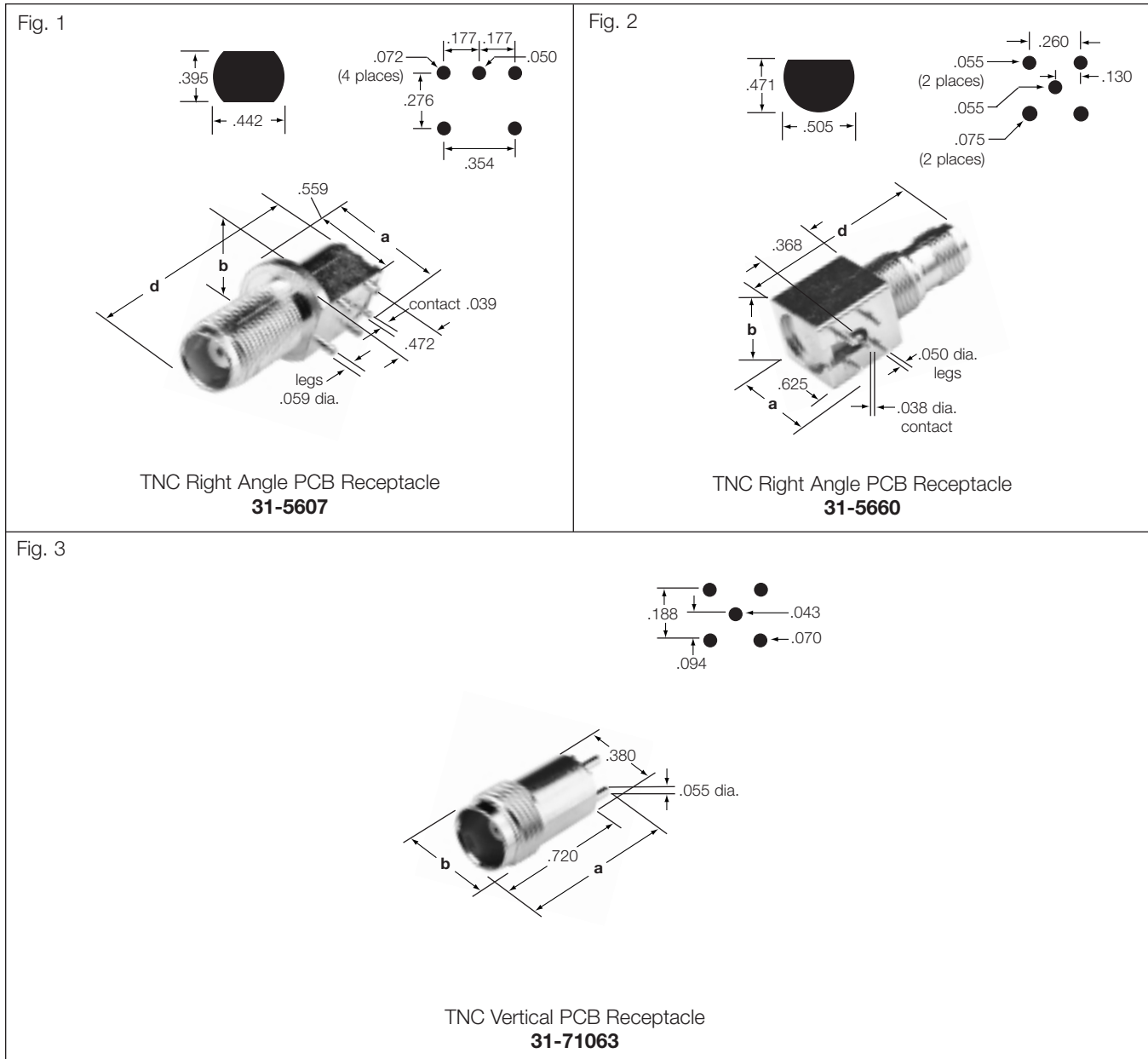

## TNC PRINTED CIRCUIT BOARD RECEPTACLES

Description	Dimensions, inches (millimeters)			Notes		Amphenol Number	Fig.
	a	b	d	Pit.	Ins.		
TNC Right Angle Printed Circuit Board Receptacle	.657 (16.7)	.642 (16.3)	1.366 (34.7)	P36/P27	D1	<b>31-5607</b>	1
TNC Right Angle Printed Circuit Board Receptacle	.756 (19.2)	.580 (14.7)	1.500 (38.1)	P6	D1/31	<b>31-5660</b>	2 ▲
TNC Vertical Printed Circuit Board Receptacle	.880(22.4)	.438 (11.1)	—	P15	D1	<b>31-71063</b>	3

▲ distributor stocked

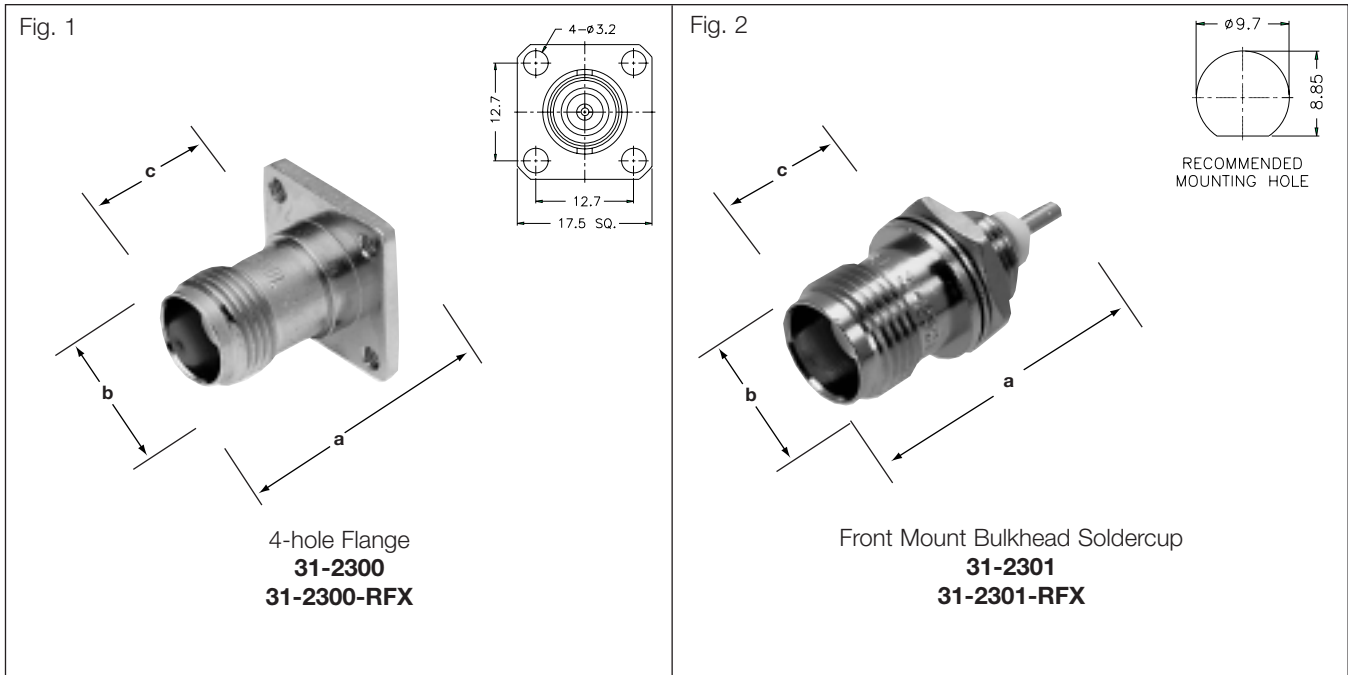

**BNC BULKHEAD CABLE JACKS**

Description	Dimensions, inches (millimeters)					Plt.	Ins.	Amphenol	Fig.
	a	b	c	d	e				
4-hole flange	.1064	.625	.125	.687	.500	P7	D1	<a href="#">31-2300</a>	1
4-hole flange	1.063	.500	.500	—	—	P7	D1	<a href="#">31-2300-RFX</a>	1
Front mount blkh Soldercup	1.05	.187	.090	.688	.500	P7	D1	<a href="#">31-2301</a>	1
Front mount blkh Soldercup	.860	.490	.425	—	—	P7	D1	<a href="#">31-2301-RFX</a>	2

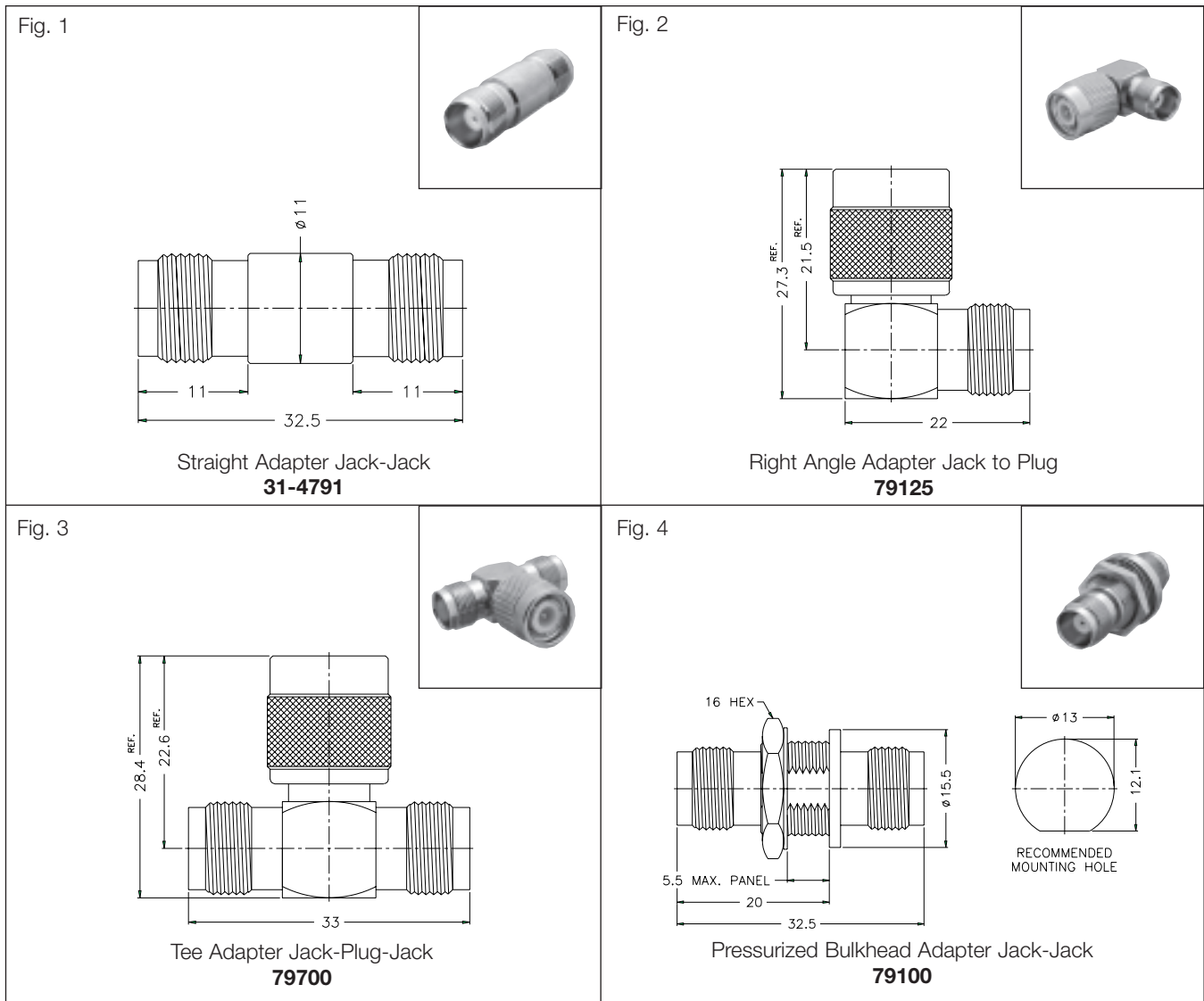

## IN SERIES ADAPTERS

Description	Dimensions, inches (millimeters)		Body	Contact	Amphenol	Fig.
	a	b				
Straight Adapter Jack-Jack	1.28 (32.5)	.437 (11.1)	Brass	P7	<a href="#">31-4791</a>	1
Right Angle Adapter Jack to Plug	1.03 (26.1)	.625 (15.9)	Brass	P7	<a href="#">79125</a>	2
Tee Adapter Jack-Plug-Jack	1.28 (32.5)	.96 (24.4)	Brass	P7	<a href="#">79700</a>	3
Bulkhead Adapters (pressurized) Jack-Jack	1.41 (35.8)	.750 (19.1)	Brass	P7	<a href="#">79100</a>	4

# Notes

Blank lined area for notes.



## Description

Reverse Polarity is a keying system accomplished with a reversed interface. This ensures, for example, a Reverse Polarity SMA does not mate with a Standard SMA.

Amphenol's RP Plugs have a female contact; Jacks have a male contact. Some competitors prefer to use reverse threading to accomplish their RP keying.

Available for RG-316, RD-316, RG-142, RG-178, Belden 9913, and RG-58 cable.

## Features/Benefits

- May be used in applications where keying is necessary to eliminate mis-matching from mating with a standard connector.
- MIL Standard 348 interface ensures high quality and premium performance.
- Crimp-crimp termination allows easy and quick assembly.
- Fits a variety of cables and configurations allowing the customer to choose the right connector for the application.

## Applications

- Antennas
- Cable Assembly
- GPS
- Spread Spectrum Wireless
- WLAN

---

### RP-SMA Connectors

Specifications	150
Connectors	151-152

---

### RP-BNC & RP-TNC

Specifications	154
TNC Connectors	155-156
BNC Connectors	157

---

### ELECTRICAL

Impedance	50 ohms
Frequency range	Semi-rigid 0-18 GHz.
	Flexible cables 0-12.4 GHz
Voltage rating	375 volts peak
Dielectric withstanding voltage	1,000 volts rms.
VSWR straight connectors	On .141" S/R: 1.05 + .005 f (GHz) On RG-174: 1.20 + .025 f (GHz)
Insertion loss	.03 $\sqrt{f}$ (GHz) dB max.
Insulation resistance	5,000 megohms
RF leakage	-60 dB min.

NOTE: These characteristics are typical and may not apply to all connectors.

### MECHANICAL

Mating	.250-36 threaded coupling
Cable affixment	Crimp or solder types
Center conductor	Solder
Cable retention	60 to 80 lbs. depending on cable

### MATERIAL

Center contacts	Beryllium copper, gold plated
Crimp ferrule	Copper tubing
Other metal parts	Non-magnetic passivated stainless steel or brass, gold or silver plated.
Insulators	TFE
Gaskets	Silicone rubber

### ENVIRONMENTAL

Temperature range	-65°C to + 165°C
Moisture Resistant	MIL-STD 202 method 106 (test condition B)
Corrosion	MIL-STD-202 method 101 (test cond. B)
Vibration	MIL-STD-202 method 204 (test cond. B)

### PLUG

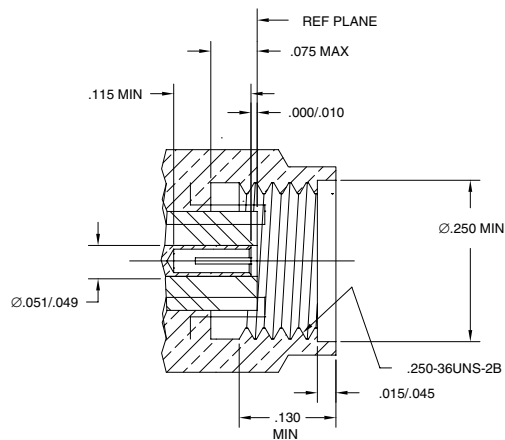

### JACK

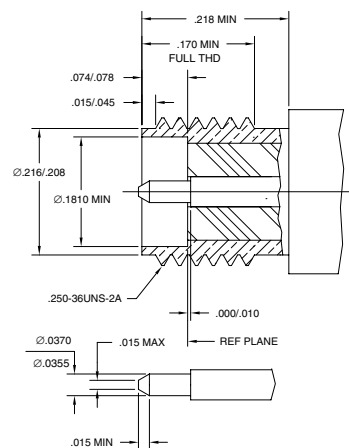



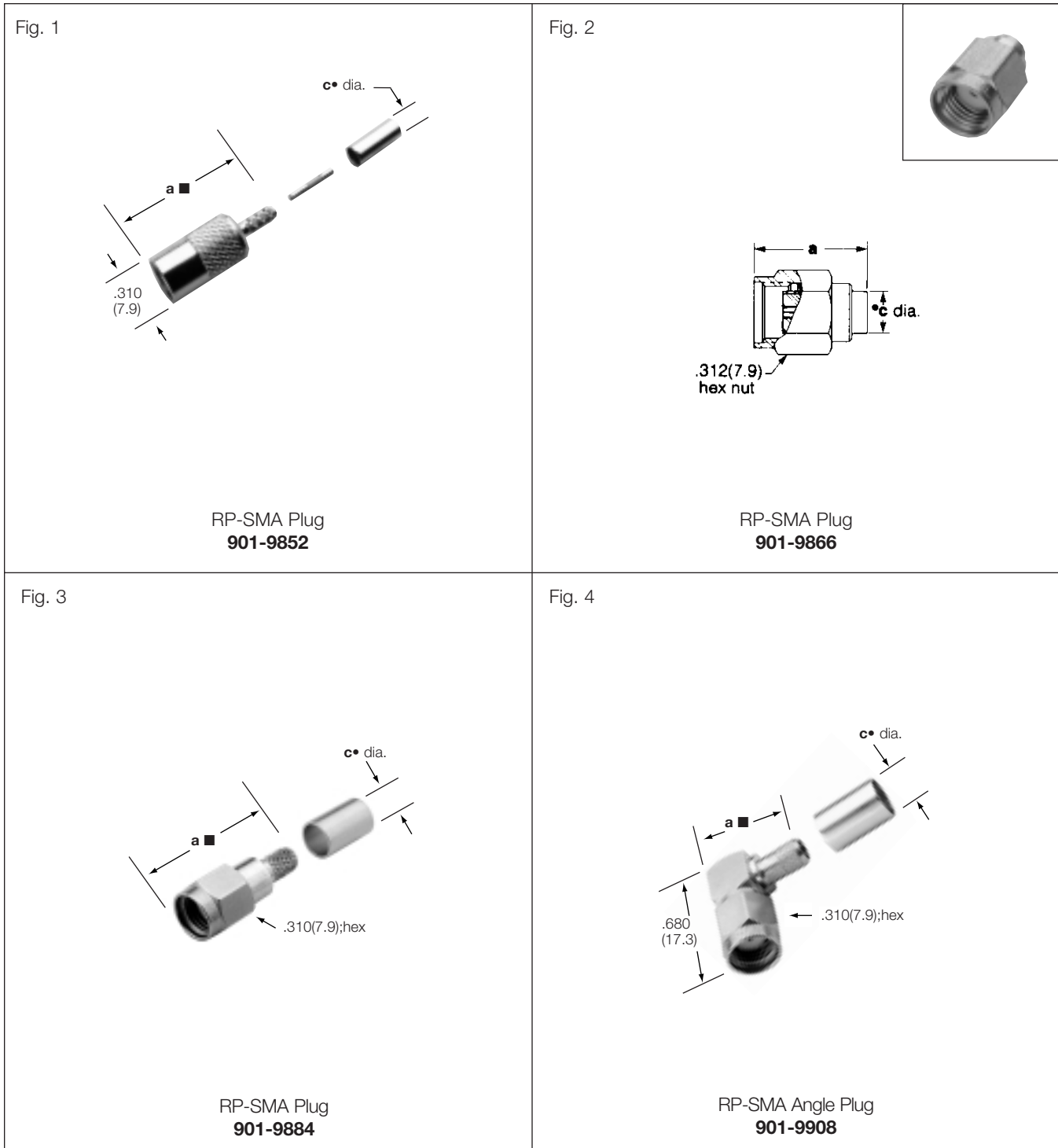

## RP-SMA PLUGS, BULKHEAD JACKS & PCB RECEPTACLES

Cable RG-/U	Conn. Type	Cable Attachment		Dimensions, in.(mm)		CAI	Plt.	Ins.	MTG. Hole	Construction Notes	Amphenol Number	Fig.
		Outer	Inner	a	c •							
55, 142, 223, 400	RP-SMA Plug	Crimp	Solder	.785(19.9)	.206(5.2)	C58	P12	D1	—	—	901-9884	3
174	RP-SMA Plug	Crimp	Solder	.940(23.9)	.128(3.2)	C58	P13	D1	—	Nickel Plated Body	901-9852	1
223	RP-SMA Ang Plug	Crimp	Solder	.560(14.2)	.220(5.6)	C58	P12	D1	—	—	901-9908	4
.141" S/R	RP-SMA Plug	Solder	Press-Fit	.480(12.2)	.145(3.7)	C59	P29	D1	—	Pre-Installed Contact	901-9866	2

■ includes outer ferrule      • inside diameter

# Reverse Polarity RP-SMA Jacks and Receptacles

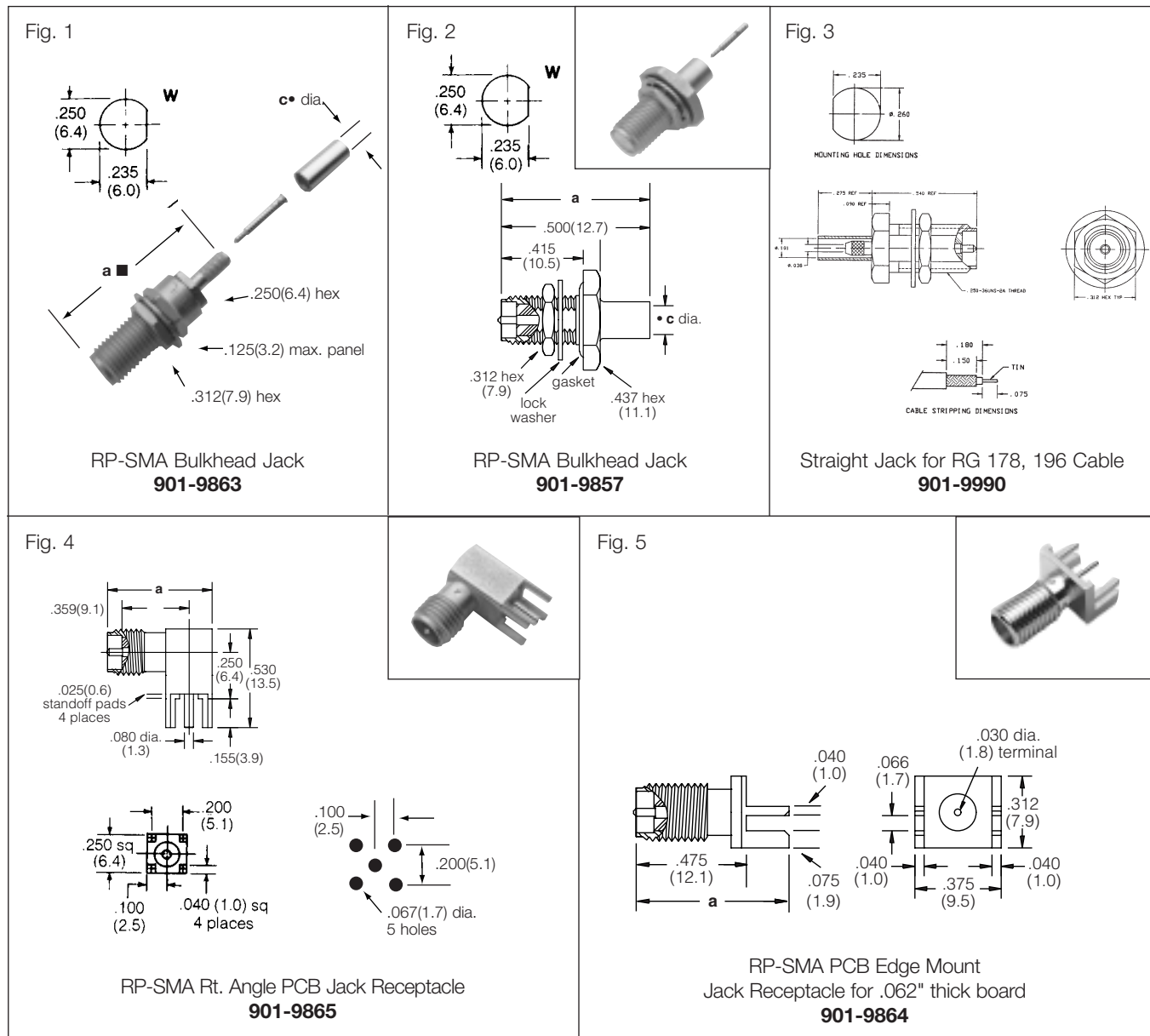

## RP-SMA BULKHEAD JACKS

Cable RG-/U	Conn. Type	Cable Attachment		Dimensions, in.(mm)		CAI	Plt.	Ins.	Construction Notes	Amphenol Number	Fig.
		Outer	Inner	a	c •						
174	RP-SMA Bulkhead Jack	Crimp	Solder	1.50(38.1)	.128(3.2)	C58	P11	D1	—	901-9863	1
.141"S/R	RP-SMA Bulkhead Jack	Solder	Solder	.750(19.0)	.145(3.7)	C59	P11	D1	Gasketed	901-9857	2
178	RP-SMA Bulkhead Jack	Crimp	Solder	.815(20.7)	.101(2.6)	C58	P12	D1	—	901-9990	3

## RP-SMA PCB RECEPTACLES

Description	Dimensions, in.(mm)		CAI	Plt.	Ins.	Construction Notes	Amphenol Number	Fig.
	a	c •						
RP-SMA Rt. Angle PCB Receptacle (J), Post Terminal	.569(14.4)	—	—	P11	D1	—	901-9865	4
RP-SMA End Mount PCB Receptacle (J), Post Terminal	.662(16.8)	—	—	P11	D1	For .062" Thick Board	901-9864	5

■ includes outer ferrule

## Description

Amphenol reverse polarity BNC, TNC & SMA connectors (RP-BNCTM, RP-TNCTM, RP-SMATM) are designed for use in spread spectrum wireless applications.

## Features/Benefits

These connectors may also be used in applications where keying is a necessity. The RP-BNCs, RP-TNCs & RP-SMAs meet the same high quality requirements as standard Amphenol BNCs, TNCs & SMAs. They provide excellent performance — DC to 4 GHz for RP-BNCs, DC to 4 GHz for RP-TNCs and DC to 18 GHz for RP-SMAs.

## Applications

- Spread Spectrum Wireless Devices
- Inventory Control



## Reverse Polarity

TNC Connectors	156
BNC Connectors	157

# Reverse Polarity RP-BNC and RP-TNC

## SPECIFICATIONS\*

### ELECTRICAL

Impedance	50 ohms
Frequency range	BNC: 0-4 GHz TNC: 0-4 GHz
Voltage rating	500 volts peak
Dielectric withstanding voltage	1,500 volts rms.
VSWR	Straight connectors 1.3 max. 0-4 GHz Right angle connectors 1.35 max. 0-4 GHz
Insertion loss	0.18 dB @ 9 GHz
Insulation resistance	5,000 megohms

### MECHANICAL

Mating	BNC: Bayonet coupling TNC: .437-28 threaded coupling
Cable affixment	Braid & jacket: hex crimp
Center conductor	Hex crimp or solder
Captivated contact	Except as noted
Cable retention	20 to 100 lbs. depending on cable

### MATERIAL

Center contacts	Male: brass. Female: beryllium copper or phosphor bronze. Gold plated
Crimp ferrule	Copper, nickel plated
Other metal parts	Brass (bright nickel finish)
Insulators	TFE
Weatherproof gaskets	Silicone rubber

\* These characteristics are typical and may not apply to all connectors.

### ENVIRONMENTAL

Temperature range	-65°C to + 165°C
Weatherproof	When mated with other Amphenol RP-TNC and RP-BNC connectors.
Corrosion	MIL-STD-202 method 101 (test cond. B)

### RP-BNC PLUG

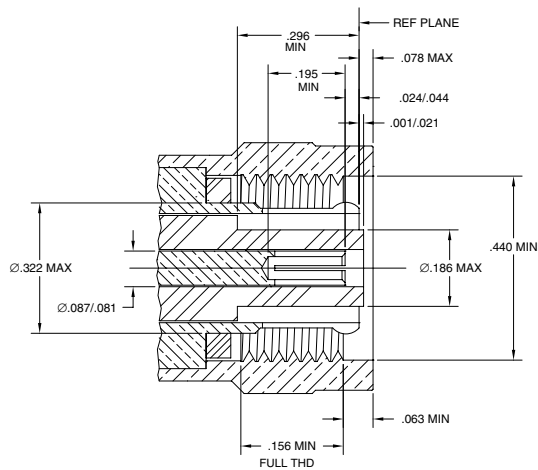

### RP-BNC JACK

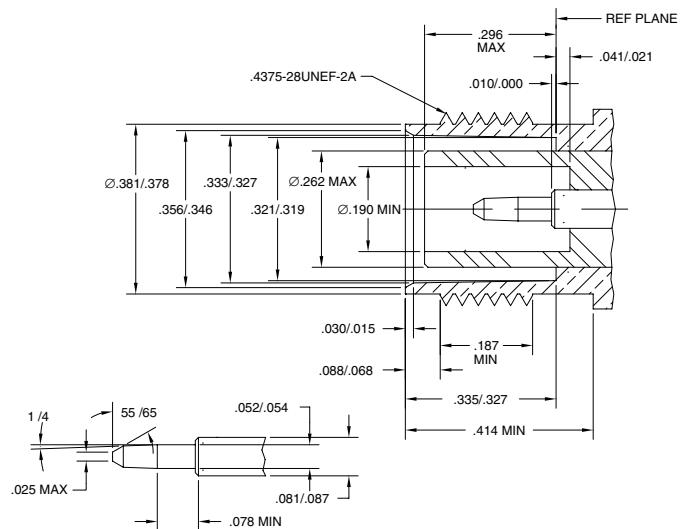

## RP-TNC PLUGS, ANGLE PLUGS, JACKS, RECEPTACLES & ACCESSORIES

Cable RG-/U	Conn. Type	Cable Attachment		Dimensions, inches (millimeters)				CAI	Plt.	Ins.	MTG Hole	Amphenol Number	Fig.
		Outer	Inner	a	b	c •	d						
58	RP-TNC Plug	Crimp	Crimp	1.12(28.4) ■	.610(15.5)	.206(5.2)	—	C38	P15	D1	—	▲ 31-5677	1
	RP-TNC Jack	Crimp	Crimp	1.17(29.7) ■	.510(12.9)	.206(5.2)	—	C38	P15	D1	—	▲ 31-5678	3
	RP-TNC Bulkhead Jack	Crimp	Crimp	1.41(35.8) ■	.795(20.2) dia	.206(5.2)	.812(20.6)	C38	P15	D1	P	▲ 31-5687	6
142	RP-TNC Plug	Crimp	Crimp	1.12(28.4) ■	.610(15.5)	.220(3.6)	—	C38	P15	D1	—	▲ 31-5677-1000	1
178	RP-TNC Panel Jack	Crimp	Crimp	1.06(27.0) ■	.972(24.1)	.114(2.9)	.625(15.9)	C38	P15	D1	T	▲ 31-5685	5
	RP-TNC Bulkhead Jack	Crimp	Crimp	1.33(33.8) ■	.795(20.2) dia	.114(2.9)	.812(20.6)	C38	P15	D1	P	▲ 31-5686	6
B9913	RP-TNC Plug	Crimp	Solder	1.29(37.8) ■	.610(15.5)	.438(11.1)	—	C38	P15	D1	—	▲ 31-5679	1
	RP-TNC Angle Plug	Crimp	Solder	1.06(26.9)	.610(15.5)	.438(11.1)	1.85(47.0) ■	C38	P15	D1	—	▲ 31-5680	2
	RP-TNC Jack	Crimp	Solder	1.41(35.8) ■	.510(12.9)	.438(11.1)	—	C38	P15	D1	—	▲ 31-5684	3
RP-TNC Panel Receptacle, Solder Cup Terminal				1.06(27.0)	.687(17.4) sq.	—	.625(15.9)	—	P15	D1	K	▲ 31-5694	4
RP-TNC Right Angle Printed Circuit Board Receptacle				.880(22.4)	.580(14.7)	—	1.500(38.1)	—	P6	D1/31	—	▲ 31-5688	7

• accommodates cable diameter ▲ distributor stocked ■ includes outer ferrule

### RP-TNC PLUG

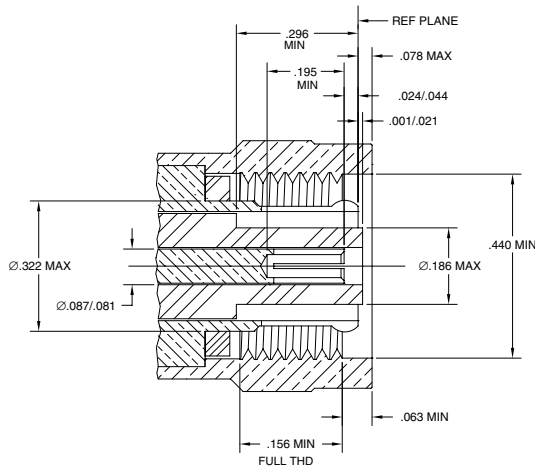

### RP-TNC JACK

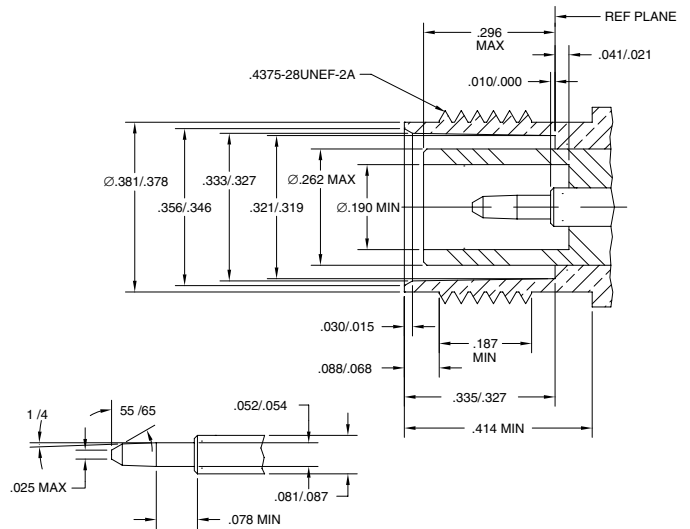

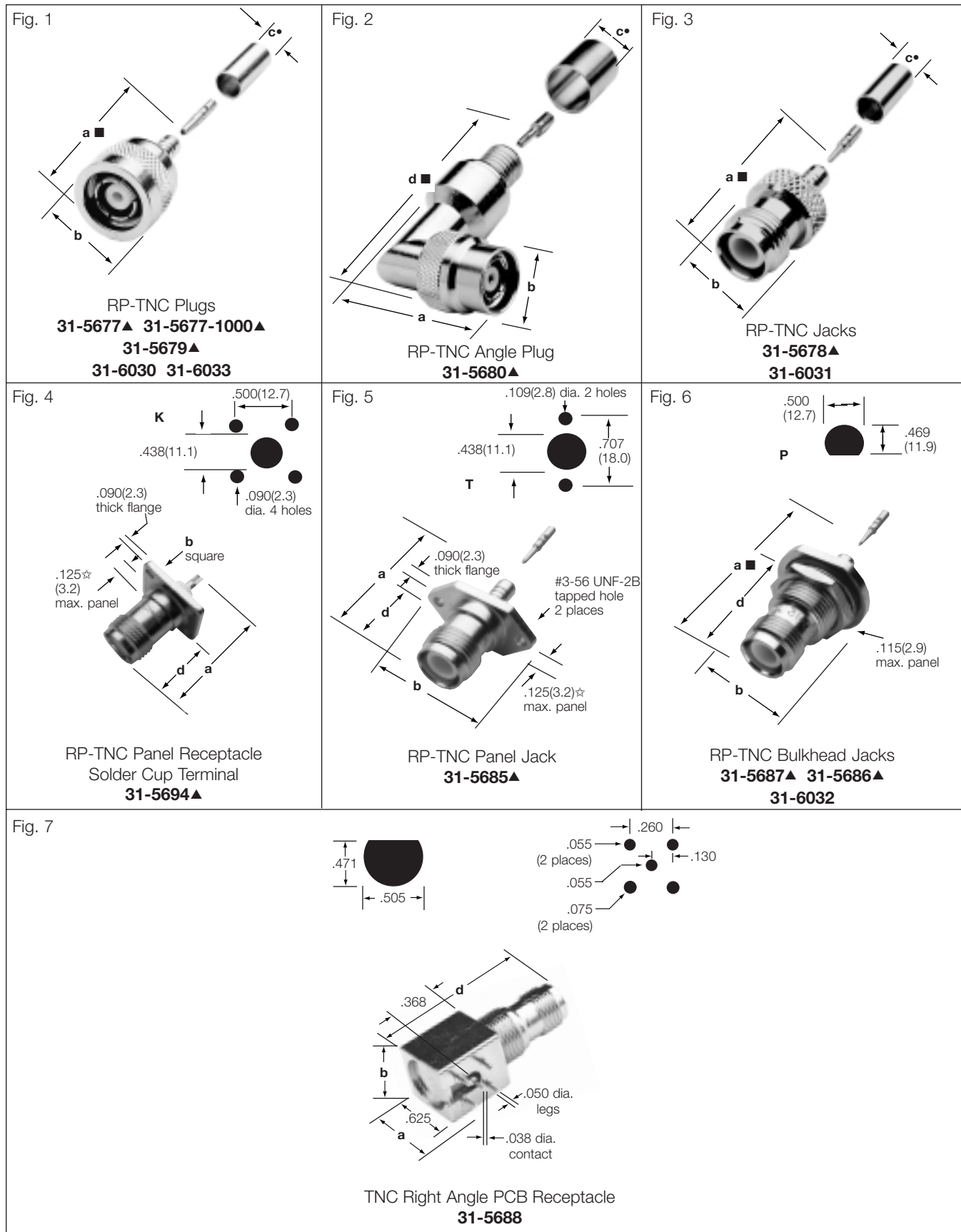

# Reverse Polarity RP-BNC Connectors

Amphenol's RP-BNC connectors provide the quick connect/disconnect bayonet lock coupling of the BNC series. The RP-BNC plug is supplied with two crimp ferrules — one for use on PVC cables and another for use on smaller diameter plenum cables.

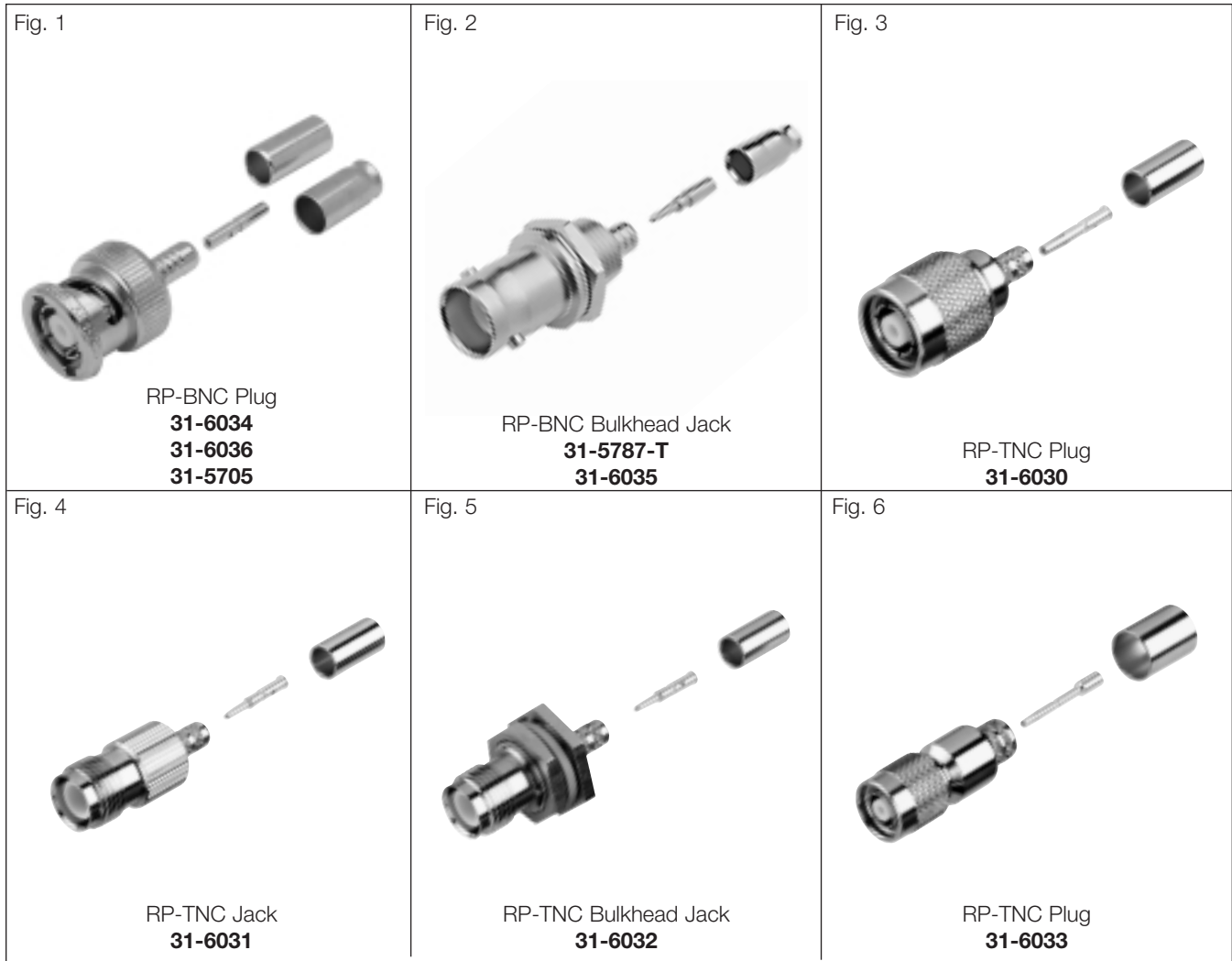

## RP-BNC/TNC PLUG

Cable RG-/U	Conn. Type	Cable Attachment		CAI	Plt.	Ins.	Amphenol Number	Fig.
		Outer	Inner					
58, 141	RP-BNC Plug	Crimp	Crimp	C38	P15	D1	<a href="#">31-5705</a>	1
174, 188, 316	RP-BNC Bulkhead Jack Front Mount	Crimp	Crimp	C38	P15	D1	<a href="#">31-5787-T</a>	2
58, 141	RP-TNC Plug	Crimp	Crimp	C38	P15	D1	<a href="#">31-6030</a>	3
58, 141	RP-TNC Jack	Crimp	Crimp	C38	P15	D1	<a href="#">31-6031</a>	4
58, 141	RP-TNC Bulk Jack	Crimp	Crimp	C38	P15	D1	<a href="#">31-6032</a>	5
8214, 9913	RP-TNC Plug	Crimp	Crimp	C38	P15	D1	<a href="#">31-6033</a>	6
8214, 9913	RP-BNC Plug	Crimp	Crimp	C38	P15	D1	<a href="#">31-6034</a>	1
58, 141	RP-BNC Jack	Crimp	Crimp	C38	P15	D1	<a href="#">31-6035</a>	2
58, 141	RP-BNC Plug	Crimp	Crimp	C38	P15	D1	<a href="#">31-6036</a>	1





**Description**

Amphenol offers a full line of termination tooling to meet your specific production requirements. All tools meet Amphenol's stringent design and quality requirements, including full cycle ratchet control, which prevents the connector from being removed from the tool prior to completing the crimping operation. Amphenol's tools provide a consistent and reliable crimp each and every time, thereby insuring the integrity of the connector termination.

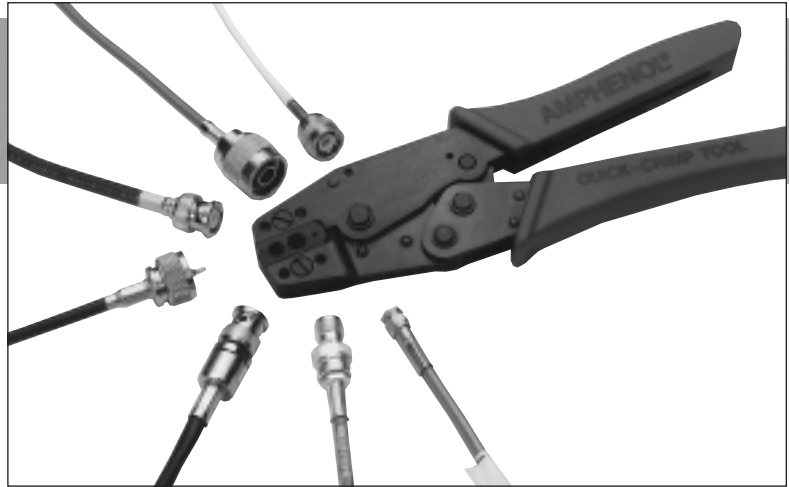

**Tools**

CTL Crimp Series	160-161
Pneumatic Bench Crimper	162
TWINHEX Crimp Tool System	162
TRIHEX Crimp	163
ECONOHEX Crimp	163
MMCX	164

## Bench Mounted Pneumatic Crimp Machine

This pneumatic-powered crimp tool makes production termination for coaxial cable easy, efficient and precise. Our compact (less than 20 pounds) unit is hand-actuated. The dual-position feet allow horizontal or vertical loading for maximum efficiency. The manually-activated mode is adaptable to either right- or left-hand operation. The connector/cable loading mechanism is spring loaded to help keep hands away from the work area during the crimp cycle. The die holder is compatible with industry standard die sets from Connex, Ideal Industries, Paladin and Sargent. The adjustable crimp height allows for termination of coaxial cable, as well as discrete wire terminations, with appropriate dies for custom crimp applications.



PCTL-S1000

## CTL Series Crimp Tools

Amphenol CTL Series crimp tools are sold complete as a tool handle with the die set included. Purchase of some or all of the seven tools shown below will allow the user to terminate most popular RG coaxial cables.

To order the crimp tool required for a specific application, please refer to the Connector Assembly Instruction for the Amphenol part number. The recommended tool number is listed under the column labeled "CTL Series Tool Number".

Cross Reference	
MIL-T-22520 Die Sets	227-No. Die Sets
/5-11, -13	-1221-11, -13
/5-09	-1221-09 & -32
/5 -57	-1221-25 & -57
-	-1414
/5-11, -13, -57 & -59	-1221-11, -13, -57 & -59 -980-1, -1409
/5-09, -13	-1221-09, -13, -980-1, -980-7
/5-13	-1221-13, -32, -980-1, -980-3

CTL Series Tool No.
CTL-1
CTL-2
CTL-3
CTL-4
CTL-5
CTL-6
CTL-8



## Tool Data

CTL Series Tool No.	Hex Sizes	Cable RG-/U	Connectors	Notes
CTL-1 ▲		<b>RG-55, 58, 141, 142, 223, 303, 400</b>  <b>RG-59, 62, 140, 210</b>  <b>Plenum 59, 62</b>		for BNC, & TNC 3-Piece Crimp Connectors
PCTL-100 Die set only for Bench Crimper	<b>Belden 9258, 9259, 9907, 89907</b>			

▲ distributor stocked

Tool Data

CTL Series Tool No.	Hex Sizes	Cable RG-/U	Connectors	Notes
<b>CTL-2</b>		<b>RG-6</b> <b>RG-174, 188, 316</b> <b>RG-179, 187</b> <b>Plenum 58</b> <b>Belden 8281</b>		for BNC & TNC 3-Piece Crimp Connectors
<b>PCTL-200</b> Die set only for Bench Crimper	.178 (4.5) .324 (8.2) .068 (1.7)			
<b>CTL-3</b>		<b>RG-55, 58, 141, 142</b> <b>223, 303, 400</b> <b>RG-8, 11, 149, 213,</b> <b>214, 225, 393</b> <b>Ethernet Cables</b>		for Type N 3-Piece Crimp Connectors
<b>PCTL-400</b> Die set only for Bench Crimper	.100 (2.5) .429 (10.9) .213 (5.4)			
<b>CTL-4</b>		<b>Belden 8227</b> <b>9207, 89207</b> <b>IBM 7362211</b> <b>Twinax Cable</b>		for Center Contacts of Twinax Plugs 82-5589 and 82-5589-RFX1
<b>PCTL-400</b> Die set only for Bench Crimper	.429 (10.9) .075 (1.9) .075 (1.9)			
<b>CTL-5</b>		<b>RG-55, 58, 141, 142</b> <b>223, 303, 400</b> <b>RG-59, 62, 140, 210</b> <b>Plenum 59, 62</b> <b>Belden 9258, 9259,</b> <b>9907, 89907</b>		for BNC, TNC, Mini-UHF, and Type N 3-Piece Crimp Connectors
<b>PCTL-500</b> Die set only for Bench Crimper	.052 (1.3) .100 (2.5) .255 (6.5) .068 (1.7) .213 (5.4)			
<b>CTL-6</b>		<b>RG-174</b> <b>RG-59, 62</b> <b>Plenum 59, 62</b>		for 50Ω and 75Ω BNC & TNC 3-Piece Crimp Connectors
<b>PCTL-600</b> Die set only for Bench Crimper	.255 (6.5) .068 (1.7) .178 (4.5) .052 (1.3)			
<b>CTL-8</b>		<b>RG-59, 62</b> <b>Plenum 59, 62</b> <b>RG-6</b>		for 50Ω and 75Ω BNC & TNC 3-Piece Crimp Connectors
<b>PCTL-800</b> Die set only for Bench Crimper	.052 (1.3) .255 (6.5) .068 (1.7) .324 (8.2)			
<b>CTL-9</b>		<b>RG-174, 188, 360, 180</b>		for SMA Crimp Connectors
<b>PCTL-900</b> Die set only for Bench Crimper	.128 (3.3) .068 (1.7) .178 (4.5)			
<b>CTL-11</b>		<b>Belden 9913, 9914,</b> <b>LMR 400</b>		for Type N 3-Piece Crimp Connectors
<b>PCTL-1100</b> Die set only for Bench Crimper	.116 (2.9) .429 (10.9)			

▲ distributor stocked

## Hand Crimp Tool



The Amphenol TWINHEX crimp tool system is used in Industrial/ Military Standard applications. It consists of a tool frame and a selection of die sets for use in assembling Amphenol RF connectors.

## Pneumatic Crimp Tool



The Amphenol pneumatic crimp tool 227-60 is designed for use in high volume RF connector/cable assembly applications. Bench mountable on a swivel base, this high speed crimp tool runs on a standard 85/100 psi air-line and is actuated by a foot switch for hands-free operation.

## Die Sets for Crimp Tool 227-944 & Pneumatic Crimp Tool 227-60

Amphenol Die Set Number	Military Die Set Number	Hex Size Inches (mm)	
		Cavity A (Outer)	Cavity B (Inner)
227-980-1	—	.255(6.5)	.049(1.2)
227-980-2 ▲	—	.178(4.5)	.049(1.2)
227-980-3 ▲	—	.324(8.2)	.052(1.3)
227-980-7	—	.178(4.5)	.052(1.3)
227-1221-3 ▲	M22520/5-03	.128(3.2)	.105(2.7)
227-1221-9 ▲	M22520/5-09	.178(4.5)	.068(1.7)
227-1221-11 ▲	M22520/5-11	.213(5.4)	.068(1.7)
227-1221-13 ▲	M22520/5-13	.255(6.5)	.068(1.7)
227-1221-15	M22520/5-15	.263(6.7)	.068(1.7)
227-1221-23 ▲	M22520/5-23	.384(9.8)	—
227-1221-25 ▲	—	.429(10.9)	.100(2.5)
227-1221-29	M22520/5-29	.324(8.2)	.100(2.5)
227-1221-32 ▲	—	.324(8.2)	.068(1.7)
227-1221-37	M22520/5-37	.314(8.0)	.151(3.8)
227-1221-57 ▲	M22520/5-57	.213(5.4)	.100(2.5)
227-1221-59	M22520/5-59	.255(6.5)	.100(2.5)
227-1221-61	—	.151(3.84)	.068(1.73)
227-1409	—	.213(5.4)	.052(1.3)sq
227-1414	—	.429(10.9)	B/C=.075(1.9)
227-1448	—	.160(4.1)	.049(1.2)

▲ distributor stocked

### Order Information

TWINHEX tool frame 227-944 (M22520/5-01) and pneumatic crimp tool 227-60 are sold without dies. To order the die set required for your application, please refer to the Connector Assembly Instruction for the connector part number. The recommended die set number is listed in the column headed "Die Set for Tool 227-944" (& for 227-60).

Military Number	Amphenol Number	Description
227-944 ▲	M22520/5-01	Hand Tool Frame for use with Twinhex 227-1221-XX and 227-980-X Die Sets (Die Sets sold separately)
227-60 ▲	—	Pneumatic Crimp Tool with Swivel Base, Foot Switch and Hose (Connects tool to foot switch) (Die Sets for 227-60 are same as those used in Hand Tool Frame 227-944 and are sold separately)

## TRIHEX Crimp Tool



The Amphenol TRIHEX crimp tool provides an economical approach to terminating crimp connectors.

This compact, easy-to-use, three-cavity hand tool incorporates the same crimping ability as most popular two-die crimp tools. But quality is not sacrificed for economy:

- **Full cycle, reinforced ratchet control** — provides the high repeatability and reliability benefit of crimp terminated connectors.
- **Heavy duty steel construction** — stands up to in-the-field use. Two models are available, providing maximum flexibility for use in a wide variety of applications.

### TRIHEX order information

Amphenol Die Set Number	Cable RG-/U	Hex Sizes Across Flats, In. (mm)		
		Cavity A	Cavity B	Cavity C
227-962 ▲	55, 58, 59, 62, 140, 141, 142, 210, 223, 303, 400	.213(5.4)	.255(6.5)	.068(1.7)
227-967	59, 62, Belden 8281	.324(8.1)	.255(6.5)	.068(1.7)

▲ distributor stocked

## ECONOHEX™ Crimp Tool and Dies

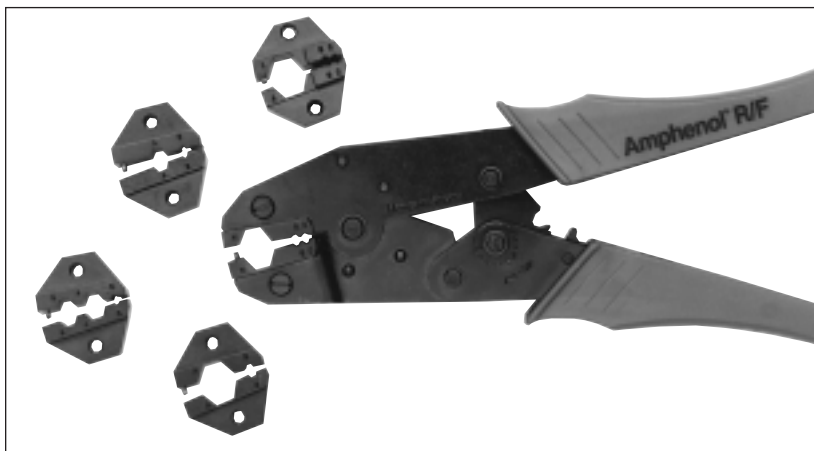

The Amphenol ECONOHEX hand crimp tool is similar in features and application to the TRIHEX crimp tools. However, the ECONOHEX provides the additional feature of die set insertion and removal such that the purchase of the ECONOHEX tool handle and some or all of the four die sets will allow the user to terminate most popular RG coaxial cables as well as Twinaxial cable for IBM system 3X networks.

### ECONOHEX order information

Amphenol Die Set Number	Cable RG-/U	Connector Series by Cavity Used	Hex Sizes Across Flats, In. (mm)	
			Cavity A (outer)	Cavity B (inner)
227-1420 ▲	8, 9, 11, 87A, 149, 165, 213, 214, 216, 225, 393	BNC, N	.429(10.9)	.100(2.5)
227-1419 ▲	55, 58, 141, 142, 142B, 223, 303, 400	BNC, RP-BNC, RP-TNC, RP-SMA	Cav. B = .213(5.4)	Cav. C = .068(1.7)
	59, 62, 140, 210, 302, Belden 9258, Amph. 621-6003	BNC	Cav. A = .255(6.5)	
227-1418 ▲	122, 180, 195, 316, Amphenol 21-597	BNC	.178(4.5)	.068(1.7)
227-1417	Belden 8227, 9207; IBM 7362211 Twinax Cable	B/C only center contacts of 82-5589 Twinax Plug	.429(10.9)	B/C = .075(1.9)
227-987 ▲	ECONOHEX Tool Handle without dies			

**CTL Crimp Tool**



Amphenol CTL Series crimp tools are sold complete as a tool handle with the die set included. Purchase of some or all of the seven tools shown below will allow the user to terminate most popular RG coaxial cables.

To order the crimp tool required for a specific application, please refer to the Connector Assembly Instruction for the Amphenol part number. The recommended tool number is listed under the column labeled "CTL Series Tool Number".

**CTL Crimp Tool order information**

Crimp Tool Part Number	Cable RG-U	Connector Series by Cavity Used	Hex Sizes Across Flats, In. (mm)		
			Cavity 1	Cavity 2	Cavity 3
<b>CTL-13</b>	RG-174, 178, 188, 196, 316, RD-316	MicroMate, SMB, SMA	.105 (2.67)	.128 (3.25)	.151 (3.84)
<b>PCTL-1300</b> Die set only for Bench Crimper					

**CAP Installation and Connector Removal Tool**

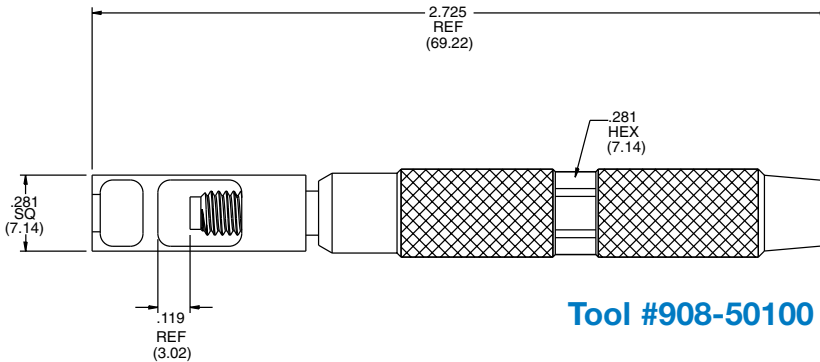

Universal tool for MicroMate (MMCX) right angle connectors for protective cap mounting and decoupling of connectors.

**Tool #908-50100**

**Tool Data**

CTL Series Tool No.	Hex Sizes	Cable RG-U	Connectors	Notes
<b>CTL-14</b>		<b>Belden 8281, 1694A</b> <b>AT&amp;T 734A</b>		for 3-Piece BNC Crimp Connectors
<b>CTL-15</b>		<b>AT&amp;T 735A</b> <b>AT&amp;T 734A</b> <b>Belden 8218</b>		for 3-Piece BNC Crimp Connectors

▲ distributor stocked

# Contents

Overview .....	166
Twinaxial .....	167
Twin BNC .....	171
Triax .....	173
UHF .....	185
Mini-UHF .....	193
C, SC, HN .....	197
FME .....	205
Between Series Adapters .....	209



Amphenol's family of "Standard" connectors includes Twinaxial, Twin BNC, UHF, Mini-UHF, Triax, C, SC, HN and FME. These units utilize threaded coupling and bayonet locking mechanisms. The standard connector line features many configurations and accommodates a large variety of RG and industry standard cables, allowing the design engineer excellent flexibility.

Amphenol's **Twinaxial** and **Twin BNC** connectors are designed for 78 and 95 ohm twin conductor cables. Twinaxial operate from DC to 200 MHz range and Twin BNC operate from DC to 100 MHz range. The Twinax polarized keyway construction and the Twin BNC polarized contact design ensure proper signal continuity of the cable connectors. They are most popular for computer/network systems and process equipment.

Amphenol's **UHF** connectors are the Grand Daddies of all RF connectors. First developed in the 1930's, they hold their age very well and are still quite popular. These units feature a threaded coupling mechanism and are general purpose; rugged units used in low frequency systems up to 300 MHz. Typical applications for the UHF connector are antenna, base stations and CB radios.

Amphenol's **C** connectors are medium-size, weatherproof types. The C design has a standard voltage

rating of 1,500 volts and low VSWR up to 11 GHz. The coupling is two stud bayonet lock. C connectors provide constant 50 ohm impedance. They may be used with 75 ohm cable, at lower frequencies (below 300 MHz) where no serious mismatch is introduced.

**Mini-UHF** are a miniature version of the UHF connectors invented in the 1930's for use in the radio industry. Mini-UHF connectors debuted in the 1970's.

Mini-UHF connectors are designed for use as coaxial interconnection in cellular mobile telephone systems and similar applications where size, weight and cost factors are critical.

These connectors terminate RG-58, -58A, -58B, -58C, and Belden 9258 cables.

Crimp-type cable plugs and jacks are available as well as panel and printed circuit board receptacles.

Amphenol **SC** connectors are medium size, constant 50 ohm impedance units manufactured to meet MIL-C-39012 category D, Specification sheets 35 through 43, meeting all of the mechanical and electrical requirements of the Limited Coordination Specification (LC Spec.) as generated by the U.S. Air Force. Connector mating is a .687-245 UNEF screw thread.

Amphenol **HN** connectors are medium size weatherproof units designed for high voltage applications. Coupling is 3/4-20 threaded. HN connectors feature captivated contact design which prevents contact recession under temperature extremes and mechanical stresses.



## Description

Twinax and Twin BNC connectors are used with 78 and 95 ohm conductor cables and operates from 0-200 MHz.

Due to the improved shielding characteristic (>30dB), these connectors are used in balanced low level and high sensitivity circuits.

Meets applicable sections of MIL-C-3655

Twinax connectors feature keyway polarization to ensure system integrity and prevent signals from being mixed. Ideal for computer network applications.

Twin BNC features the same two-stud bayonet locking mechanism as standard BNC connectors and polarized contacts (one female, one male) to prevent signals from being mixed. They are ideal for computer network and process control devices.

## Features/Benefits

- Polarized key and keyway construction guarantees correct dual contact mate.
- Twinax center pins can be crimped or soldered to provide dual signals from one connector.
- Large threaded connectors designed for rugged use.
- Crimp contacts ensures lower cost of installation.
- Clamp assembly allows quick assembly without requiring special tools.
- 2 Stud bayonet design allows quick and easy coupling.

## Application

- Cable Assemblies
- Components
- Mil-Aerospace
- Computer Networks/LAN
- Process Equipment



### Twinax

Specifications	168
Connectors	169-170

### Twin BNC

Specifications	171
Connectors	172

## ELECTRICAL

Impedance	Used with 78 ohm and 95 ohm twin conductor cables.
Frequency range	Keyway polarization: 0-200 MHz, 0-500 MHz with caution.
Voltage rating	Keyway polarization: 500 volts peak.

## ENVIRONMENTAL

Temperature range	Copolymer of Styrene: - 55°C to +85°C Noryl: - 45°C to +121°C
Weatherproof	All Twinax Contact connectors are weatherproof when mated.

NOTE: These characteristics are typical and may not apply to all connectors.

## MECHANICAL

Mating	Keyway polarization: 3/4-20 threaded coupling keyed 90°
Cable affixment	Braid clamp, "V" groove gasket and clamp nut mechanism.

## MATERIAL

Contacts	Male: brass Female: beryllium copper. Silver plated or gold plated.
Other metal parts	Brass: Nickel finish
Insulators	Copolymer of styrene, Noryl, or polyester, as listed.
Clamp gaskets	Silicone rubber or synthetic rubber

## MILITARY SPECIFICATIONS

Amphenol twinaxial connectors, polarized key and keyway construction, meet applicable sections of MIL-C-3655.

## PLUG

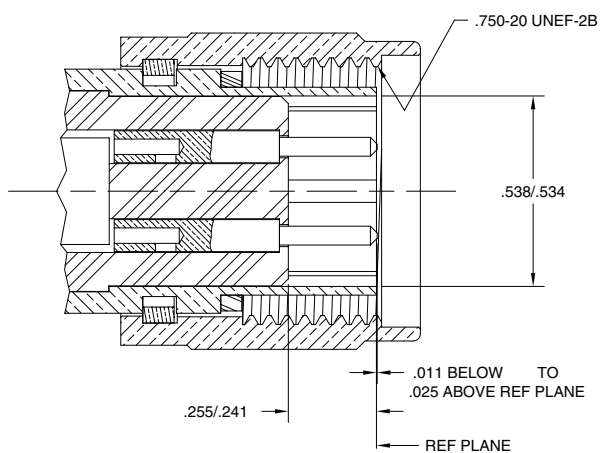

## JACK

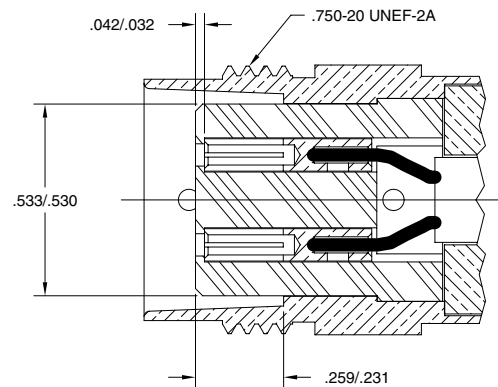

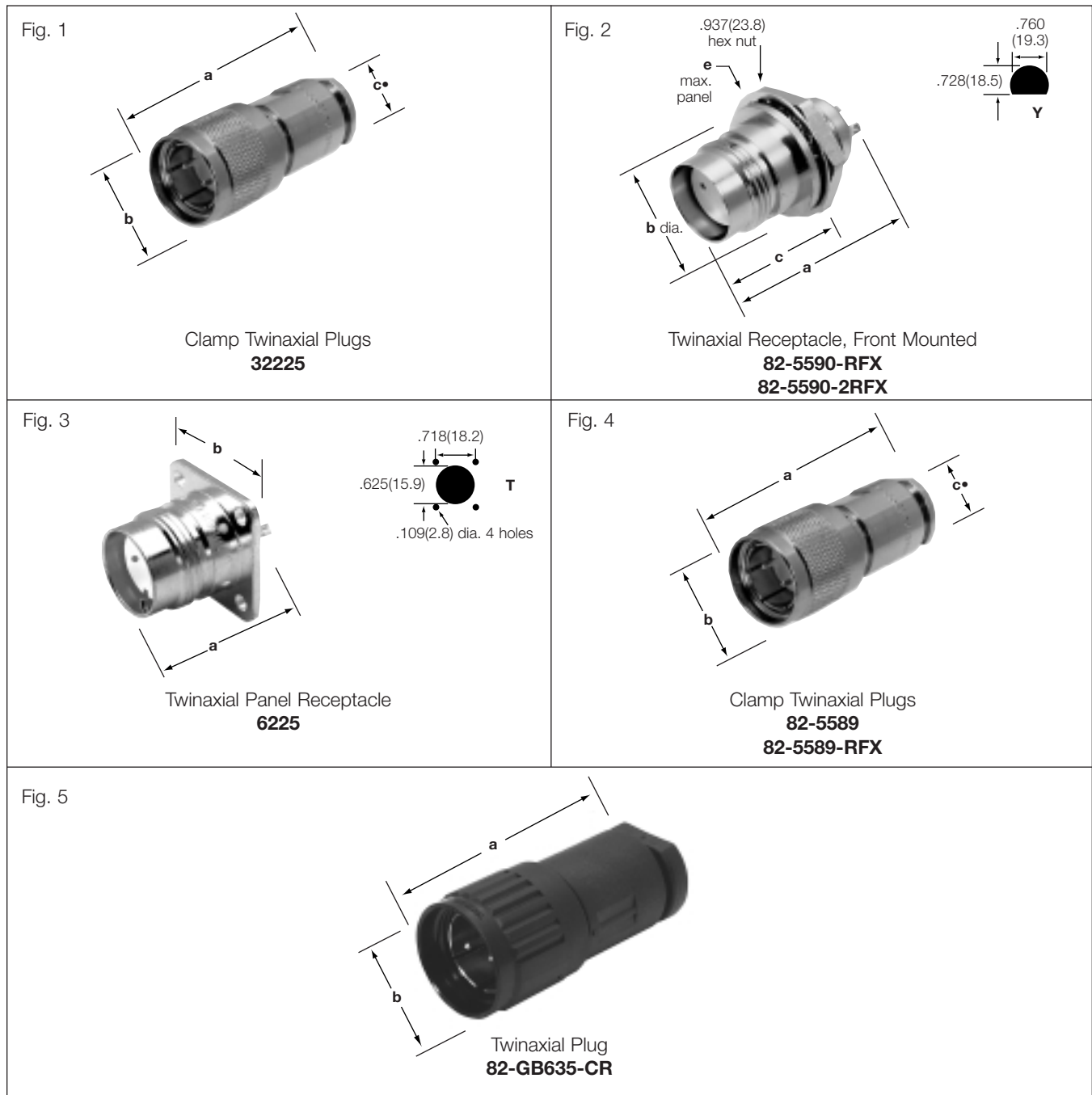

Twinaxial

## TWINAXIAL PLUGS, RECEPTACLES

Cable/ Description		Cable Attachment		Dimensions, inches (millimeters)				Notes			Mtg. Hole	IBM Ref. Number	Amphenol Number	Fig.
		Outer	Inner	a	b	c	e	CAI	Plt.	Ins.				
<b>RG-22</b>	Plug	Clamp	Solder	1.75(44.5)	.875(22.2)	.444(11.3)●	—	C19	P4	D6	—	5052750	<b>32225</b>	1
Receptacle, Front Mount, Solder Cup Terminals				1.58(40.1)	.945(24.0)	.787(20.0)	.295(7.5)	—	P7	D25	Y	—	<b>82-5590-RFX</b>	2
Receptacle, Front Mount, Solder Cup Terminals				1.58(40.1)	.945(24.0)	.787(20.0)	.295(7.5)	—	P1	D25	Y	—	<b>82-5590-2RFX</b>	2
Panel Receptacle		—		1.19(30.2)	1.00(25.4)	—	—	—	P4	D6	T	—	<b>6225</b>	3
<b>Times AA-6026, AA6076, AA-6079 Brand Rex T8756A Belden 8227, 9207 IBM 7362211</b>	Plug	Clamp	Solder or Crimp	1.89(48.0)	.890(22.6)	.340(8.7)●	—	C19	P1	D12	—	7362229	<b>82-5589</b>	4
				1.89(48.0)	.890(22.6)	.340(8.7)●	—	C19	P15	D22	—	—	<b>82-5589-RFX</b>	4
			Solder	1.85(47)	.890(22.6)	.340(8.7)●	—	C10	P27	D19	—	—	<b>82-GB635-CR</b>	5

● accommodates cable diameter

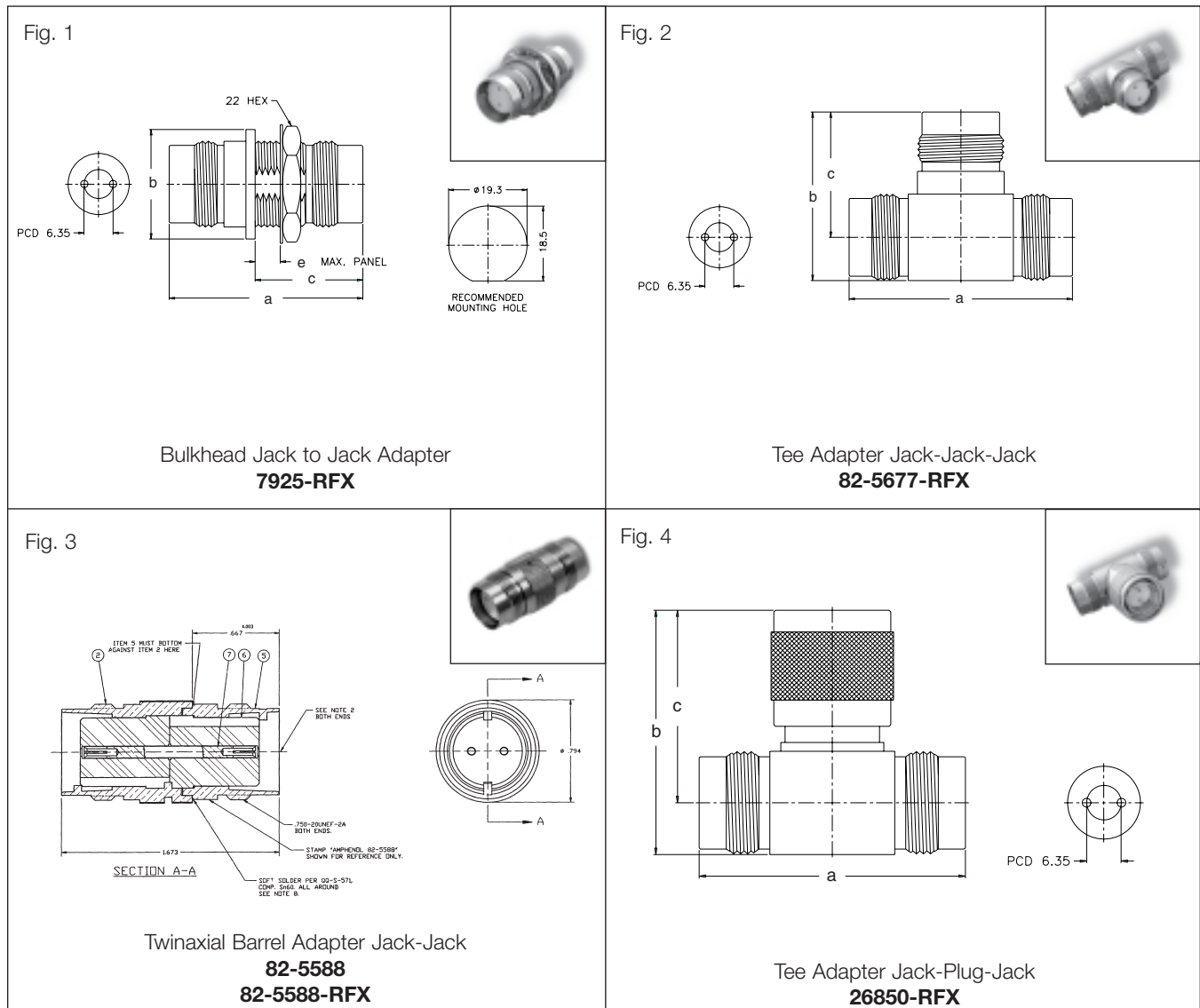

## TWINAXIAL ADAPTERS

Cable/ Description	Dimensions, inches (millimeters)				Notes			Mtg. Hole	IBM Ref. Number	Amphenol Number	Fig.
	a	b	c	e	CAI	Pit.	Ins.				
Bulkhead Jack to Jack Adapter	1.67 (42.4)	.945 (ø24)	1.32 (33.6)	.217 (5.5)	—	P7	D25	Y	—	<b>7925-RFX</b>	1 ▲
Tee Adapter Jack-Jack-Jack	1.93 (49)	1.46 (37)	1.08 (27.5)	—	—	P15	D25	—	68-51167	<b>82-5677-RFX</b>	2 ▲▲
Barrel Adapter, Jack-Jack	1.67(42.4)	.768(19.5)	—	—	—	P1	D12	—	—	<b>82-5588</b>	3 ▲▲
Barrel Adapter, Jack-Jack	1.67(42.4)	.768(19.5)	—	—	—	P7	D25	—	—	<b>82-5588-RFX</b>	3 ▲▲
Tee Adapter Jack-Plug-Jack	1.93 (49)	1.77 (45)	1.40 (35.5)	—	—	P15	D25	—	4178269	<b>26850-RFX</b>	4 ▲▲

● accommodates cable diameter ▲ Distributor stocked

## ELECTRICAL

Impedance	Used with 78 ohm and 95 ohm twin conductor cables.
Frequency range	Contact polarization: 0-100 MHz.
Voltage rating	Contact polarization: 100 volts peak.

## ENVIRONMENTAL

Temperature range	TFE: - 65°C to + 165°C Noryl: - 45°C to + 121°C
Weatherproof	All Twin-BNC connectors are weatherproof when mated

## MILITARY SPECIFICATIONS

Amphenol twinaxial connectors, polarized contact construction, meet applicable sections of MIL-C-3655.

## MECHANICAL

Mating	Contact polarization, 2 stud bayonet
Cable affixment	Braid clamp, "V" groove gasket and clamp nut mechanism.

## MATERIAL

Contacts	Male: brass Female: beryllium copper. Silver plated.
Other metal parts	Brass: nickel finish
Insulators	TFE or Noryl as listed.
Clamp gaskets	Silicone rubber or synthetic rubber

NOTE: These characteristics are typical and may not apply to all connectors.

## PLUG

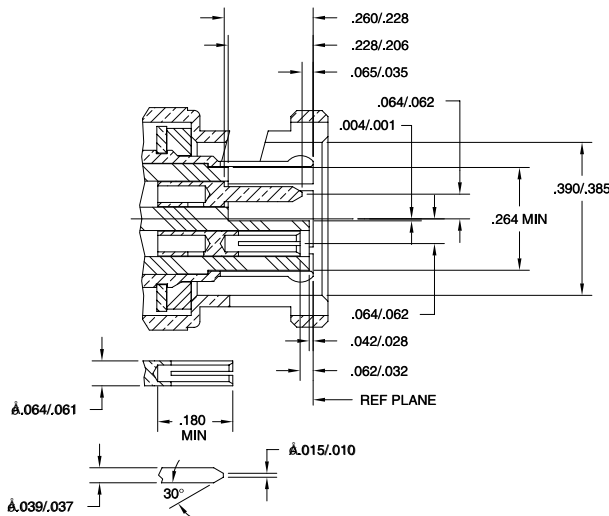

## JACK

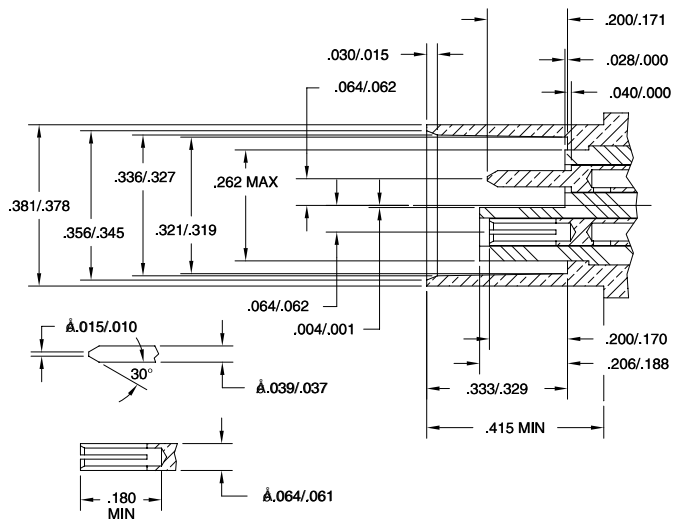

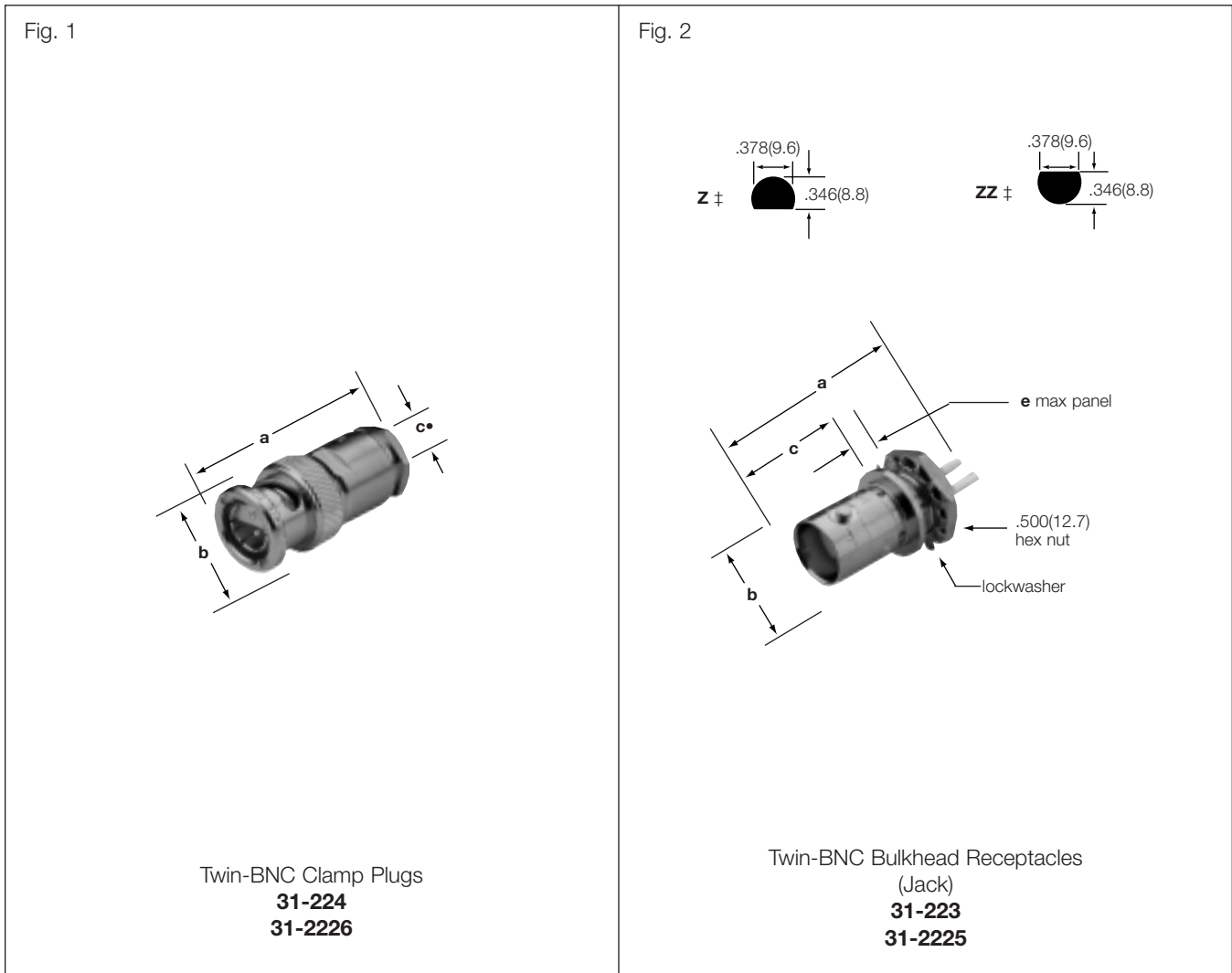

**Twin-BNC PLUGS & RECEPTACLES**

Cable RG-/U	Conn. Type	Cable Attachment		Dimensions, inches (millimeters)				Construction Notes			Mtg. Hole	Military Number	Amphenol Number	Fig.
		Outer	Inner	a	b	c	e	CAI	Pt.	Ins.				
108A	Plug	Clamp	Solder	1.16(29.4)	.563(14.3)	.255(6.5)•	—	C33	P1	D19	—	—	31-224	1
										D1	—	—		
Bulkhead Receptacle (Jack) Front Mount				1.03(26.2)	.500(12.7)	.531(13.5)	.106(2.7)	—	P1	D19	Z‡	—	31-223	2
D1	ZZ‡	—	31-2225											

‡ NOTE: Use mounting hole as shown to assure proper orientation of solder cups. • accommodates cable diameter ▲ distributor stocked

**Description**

Amphenol Triax connectors are used in applications where maximum RF shielding and minimum noise radiation are required.

**Features/Benefits**

- Available in 7/8-20 and 11/16-24 threading, Triax C, Triax BNC and Triax TNC coupling provides customer flexibility in their design.
- 5000V peak with Teflon insulators allows for high temperature applications.
- Solder/Clamp assembly procedure requires no special crimp tools.
- Precision machined for consistent performance provides dependability.

**Applications**

- MIL-Aerospace
- Air-frame
- Shipboard



**Triax**

Specifications	174
Triax 7/8-20, 11/16-24 Specifications	175
Triax C Specifications	176
Triax BNC Specifications	177
Triax TNC Specifications	178
Triax BNC, 180° Polarity	179
Triax-C Bayonet Lock	180
Triax threaded 7/8-20, 11/16-24	181-182
Triax TNC threaded 7/16-28	183

## ELECTRICAL

Impedance	Non-constant (can be used with 50, 75 and 93 ohm triaxial cables)
Frequency range	7/8-20 & 11/16-24 triax 300 MHz Triax-C. Triax BNC Triax-TNC: 0-500 MHz
Voltage	5000 V peak with TFE insulators  1900 V peak with styrene insulators

## ENVIRONMENTAL

Temperature range	TFE - 65°C to +165°C Copolymer of Styrene: - 55°C to +85°C
Weatherproof	except as noted, all Triax are weatherproof

## MECHANICAL

Mating	Triax: 7/8-20 or 11/16-24 threaded coupling. Triax-C and Bayonet lock
Triax-BNC:	Triax-TNC: 7/16-28 threaded coupling
Cable affixment	Screw thread-nut and two braid clamps

## MATERIAL

Contacts	Male: brass Female & Outer beryllium copper. Silver plated.
Other metal parts	Brass: ASTROplate® finish
Insulators styrene	TFE or copolymer of
Clamp gaskets	Silicone rubber or synthetic rubber

NOTE: These characteristics are typical and may not apply to all connectors.



### 7/8-20 PLUG

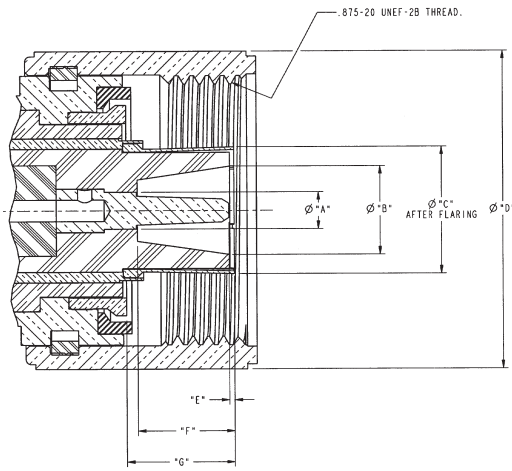

LTR	INCHES		MILLIMETERS	
	MIN	MAX	MIN	MAX
A	.119	.121	3.02	3.07
B	.286	.290	7.26	7.37
C	.431	.435	10.95	11.05
D	1.029	1.035	26.14	26.29
E	0	.040	0	1.02
F	.299	.329	7.59	8.36
G	.335	.365	8.51	9.27

### 7/8-20 JACK

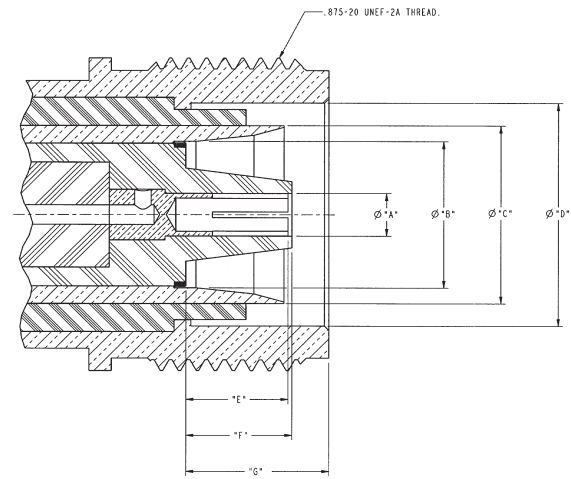

LTR	INCHES		MILLIMETERS	
	MIN	MAX	MIN	MAX
A	.119	.121	3.02	3.07
B	.411	.414	10.44	10.52
C	.496	.499	12.60	12.67
D	.625	.627	15.82	15.93
E	.269	.299	6.83	7.59
F	.280	.310	7.11	7.87
G	.383	.413	9.73	10.49

### 11/16-24 PLUG

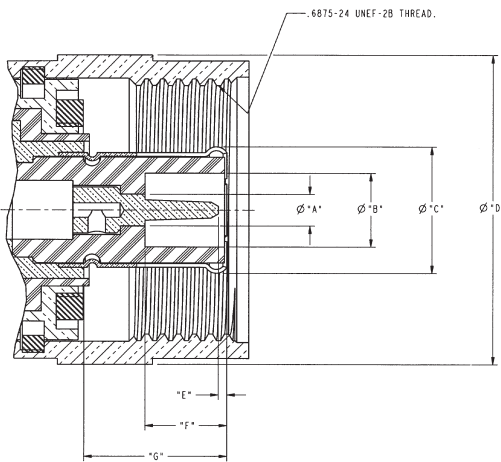

LTR	INCHES		MILLIMETERS	
	MIN	MAX	MIN	MAX
A	.082	.084	2.08	2.13
B	.189	.199	4.80	5.05
C	.328	.338	8.33	8.59
D	.807	.817	20.50	20.75
E	.008	.042	0.20	1.07
F	.198	.228	5.08	5.79
G	.359	.389	9.12	9.88

### 11/16-24 JACK

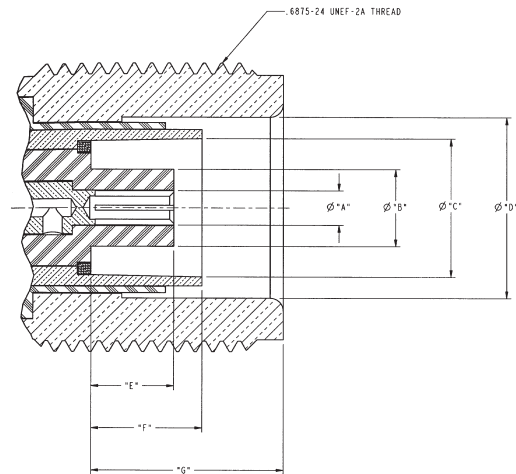

LTR	INCHES		MILLIMETERS	
	MIN	MAX	MIN	MAX
A	.082	.084	2.08	2.13
B	.182	.186	4.22	4.72
C	.330	.335	8.38	8.51
D	.430	.433	10.92	11.00
E	.182	.212	4.62	5.38
F	.249	.279	6.32	7.09
G	.442	.472	11.23	11.99

## PLUG

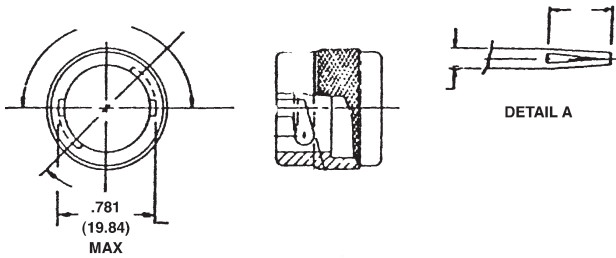
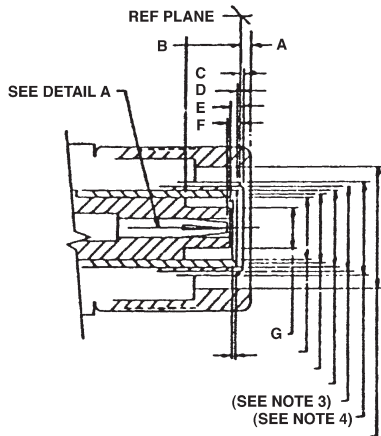

LTR	INCHES		MILLIMETERS	
	MIN	MAX	MIN	MAX
A	—	.085	—	2.16
B	.208	.250	5.28	6.35
C	.003	.021	.08	.53
D	.001	.031	.03	.79
E	.001	.043	.03	1.09
F	.001	.055	.03	1.40
G	—	.186	—	4.72

## JACK

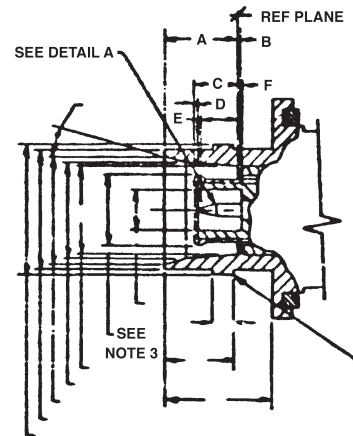

LTR	INCHES		MILLIMETERS	
	MIN	MAX	MIN	MAX
A	.332	.338	9.43	8.59
B	.001	—	.03	—
C	.186	.208	4.72	5.28
D	.001	.013	.03	.33
E	.155	.201	3.94	5.11
F	.001	.039	.03	.99

Notes:

1. Dimensions are in inches.
2. Metric equivalents are given for general information only and are based upon 1.00 inch = 25.4mm
3. Flared to meet gage test.
4. Flat or radius
5. A concave depression .100 (2.54mm) wide by .005 (.13mm) deep between studs is permissible.
6. Metric equivalents are in parentheses.

## PLUG

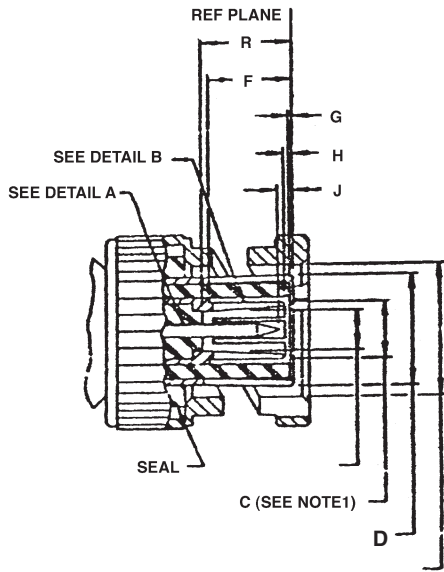

LTR	INCHES		MILLIMETERS	
	MIN	MAX	MIN	MAX
C	—	See Note 1	—	—
D	—	—	—	—
F	.213	.242	5.41	6.15
G	.001	—	.03	—
H	.007	.033	.18	.84
J	.008	.042	.20	1.07
R	.213	—	5.41	—

NOTE 1: Flared to meet mating characteristic test.

## JACK

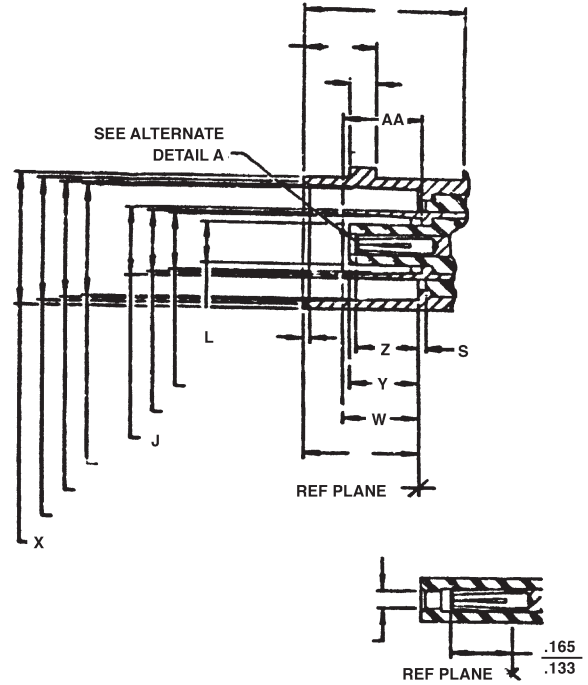

LTR	INCHES		MILLIMETERS	
	MIN	MAX	MIN	MAX
AA	.206	.213	5.23	5.41
J	.195	.199	4.95	5.05
R	.378	.382	9.60	9.70
S	.001	—	.03	—
W	.187	.213	4.75	5.41
Y	—	.213	—	5.41
Z	.165	.203	4.19	5.16

**PLUG**

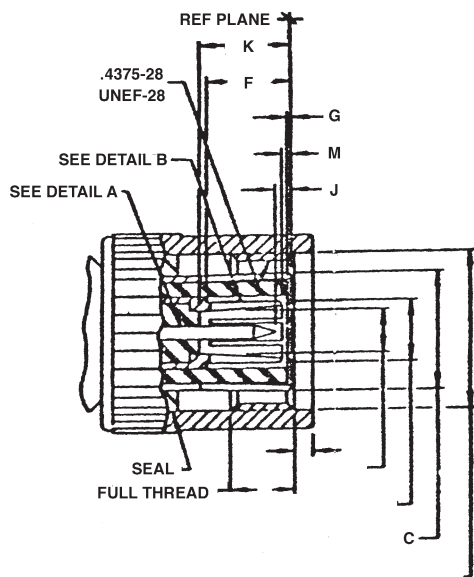

LTR	INCHES		MILLIMETERS	
	MIN	MAX	MIN	MAX
C	.172	.178	4.37	4.52
F	.213	.242	5.41	6.15
G	.001	—	.03	—
H	.007	.033	.18	.84
J	.008	.042	.20	1.07
K	.213	—	5.41	—

**JACK**

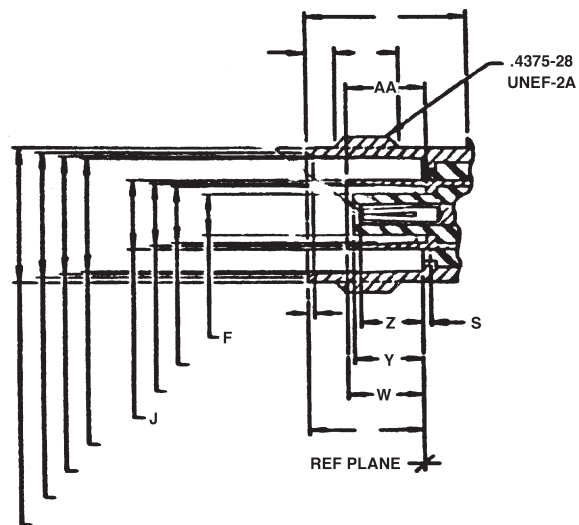

LTR	INCHES		MILLIMETERS	
	MIN	MAX	MIN	MAX
F	.117	.122	2.97	3.10
J	.195	.199	4.95	5.05
S	.001	—	.03	—
W	.187	.213	4.75	5.41
Y	—	.213	—	.41
Z	.165	.263	4.19	5.16
AA	.203	.213	5.23	5.41

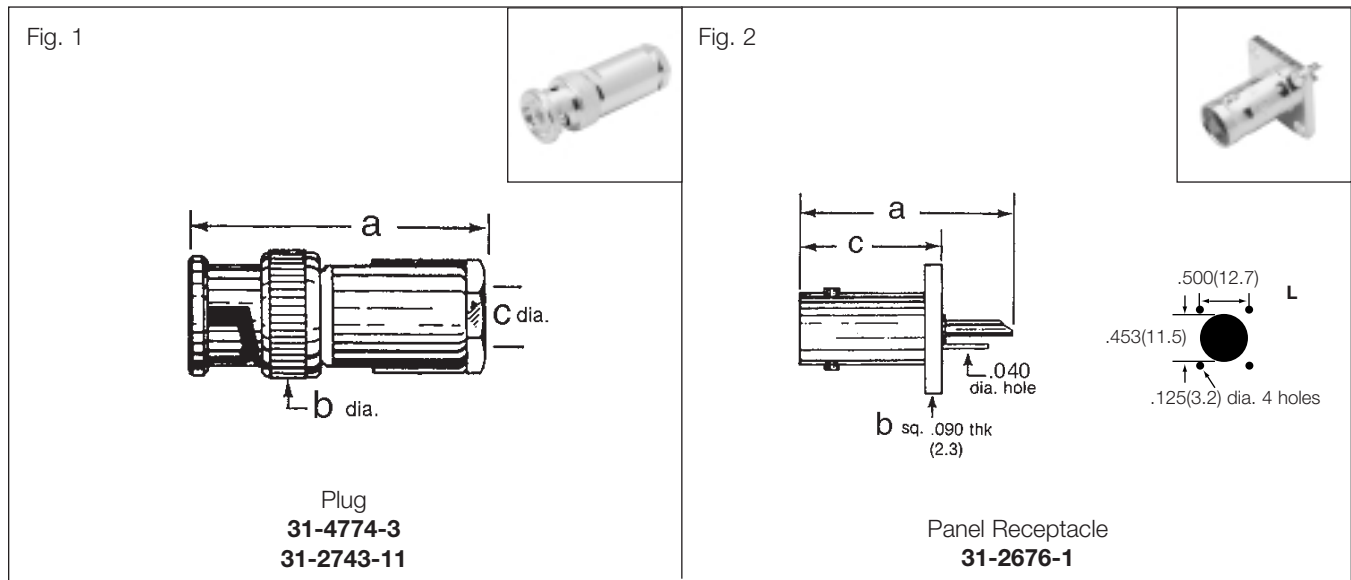

**PLUGS - MALE CONTACTS**

Cable	Config	Term	Construction	a	b	c Dia	MTG Hole	CAI	Pit.	Ins.	Amphenol Number	Fig
RG-307A/U 75Ω Triax	Plug	two braid clamp	Mates with two bayonet studs 180°	1.37 (34.9)	0.562 (14.3)	0.298 (7.6)	—	C12	33	D1	<a href="#">31-4774-3</a>	1
50Ω Triax: Times TRF-58, Belden 9222, 72Ω Triax Amphenol 621-106	Plug	two braid clamp	Mates with two bayonet studs 180°	1.37 (34.9)	0.562 (14.3)	0.257 (6.5)	—	C13	15	D1	<a href="#">31-2743-3</a>	1

**RECEPTACLES**

Config	Term	Construction In. (mm)	a	b	c Dia	MTG Hole	CAI	Pit.	Ins.	Amphenol Number	Fig
Panel Receptacle	Solder cup & ground tab	Two bayonet studs 180° apart	1.08 (27.4)	.687 (17.5)	.712 (18.1)	L	—	33	D1	<a href="#">31-2676-1</a>	2

- accommodates cable diameter

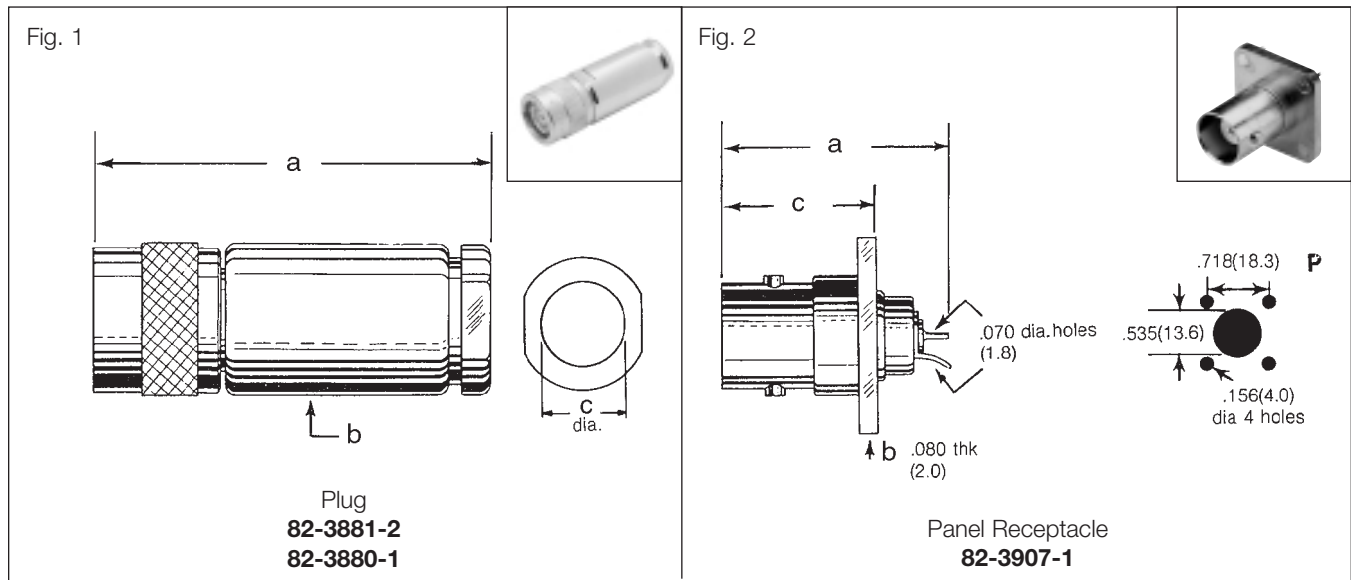

**PLUGS - MALE CONTACTS**

Cable	Config	Term	a	b	c Dia	MTG Notes	CAI Hole	Pit.	Ins.	Amphenol Number	Fig
11 Type	Plug	two braid clamps	2.06 (52.5)	0.79 (19.1)	0.298 (7.6)	—	C23	P33	D1	<a href="#">82-3881-2</a>	1
59 Type	Plug	two braid clamps	2.06 (52.5)	0.79 (19.1)	0.34 (8.6)	—	C23	P33	D1	<a href="#">82-3880-1</a>	1

**RECEPTACLES - FEMALE CONTACTS**

Cable	Config	Term	Construction Notes	a	b	c Dia	MTG Hole	CAI	Pit.	Ins.	Amphenol Number	Fig
—	Panel Receptacle	Spade Lug & Ground Tab	Gasketed	1.22 (30.9)	1.00 (25.4)	.750 (19.1)	P	—	P33	D1	<a href="#">82-3907-1</a>	2

- accommodates cable diameter

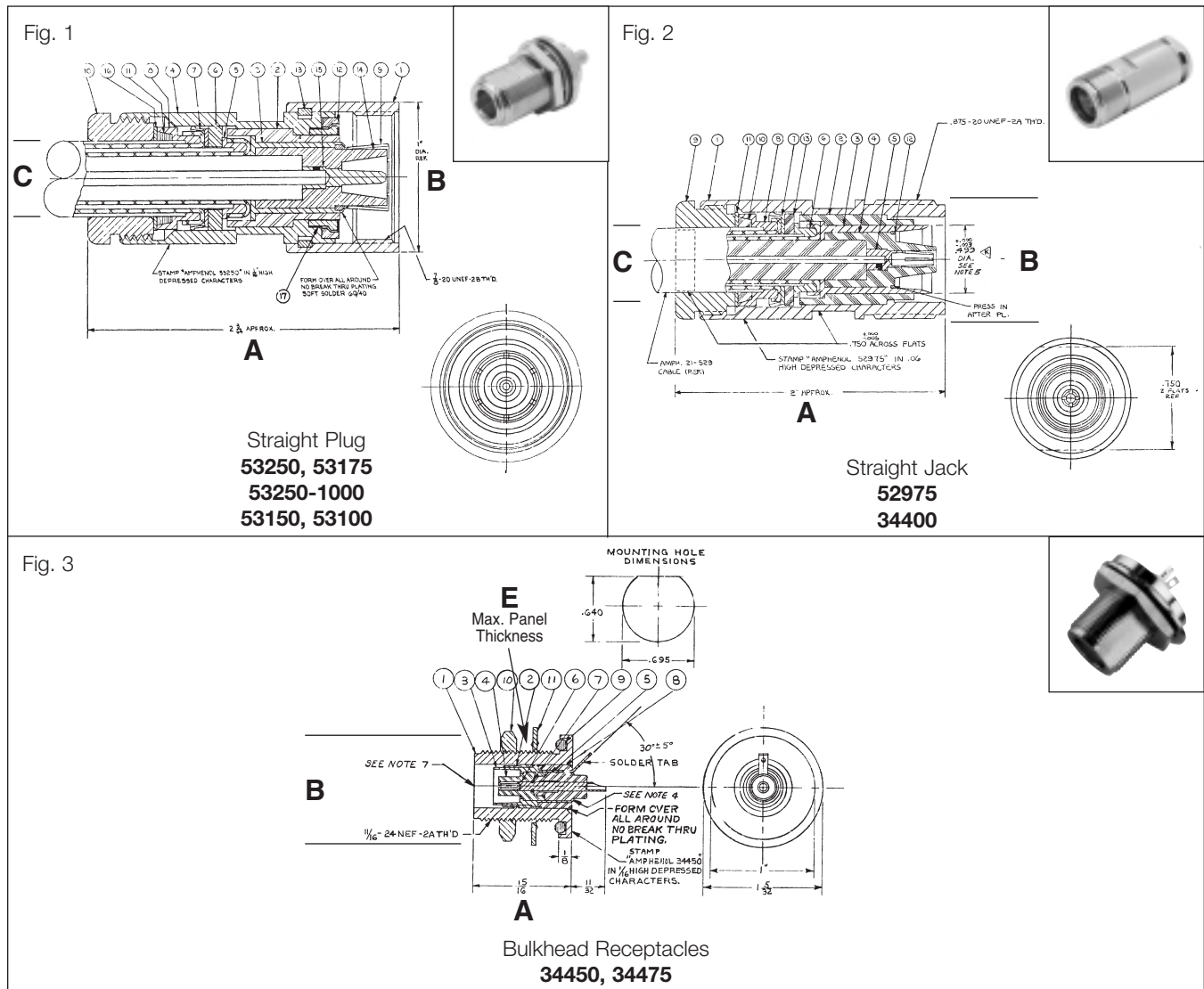

## STRAIGHT PLUGS

Triax Cable	Mating Threads	Dims. Inches (mm)					MTG Hole	CAI	PLT	Ins.	Amphenol Number	Fig
		a	b	c	e	f						
8 Type	7/8-20	2.05 (52.0)	1.00 (25.4)	.505 (12.8)	—	—	—	C15	P1	D1/D22	53250	1
11 Type	7/8-20	2.05 (52.0)	1.00 (25.4)	.475 (12.1)	—	—	—	C15	P1	D1/D22	53175	1
Coax RG-12 A/U	7/8-20	2.56 (65.1)	1.00 (25.4)	.484 (12.3)	—	—	—	C15	P1	D1/D22	53250-1000	1
58A Type	11/16-24	1.66 (42.1)	.781 (19.8)	.296 (7.5)	—	—	—	C15	P1	D1/D22	53150	1
59	11/16-24	1.66 (42.1)	.781 (19.8)	.332 (8.4)	—	—	—	C15	P1	D1/D22	53100	1

## STRAIGHT JACKS

Triax Cable	Mating Threads	Dims. Inches (mm)					MTG Hole	CAI	PLT	Ins.	Amphenol Number	Fig
		a	b	c	e	f						
11 Type	7/8-20	2.00 (50.8)	1.00 (25.4)	.475 (12.1)	—	—	—	C15	P1	D6	52975	2
59	11/16-24	1.75 (44.5)	.750 (19.1)	.332 (8.4)	—	—	—	C15	P1	D1	34400	2

## BULKHEAD RECEPTACLES

Triax Cable	Mating Threads	Dims. Inches (mm)					MTG Hole	CAI	PLT	Ins.	Amphenol Number	Fig
		a	b	c	e	f						
—	11/16-24	1.28 (32.5)	1.00 (25.4)	—	.156 (4.0)	—	Y	—	P1	D1	34450	3
—	7/8-20	1.28 (32.5)	1.25 (31.8)	—	.156 (4.0)	—	Z	—	P1	D1	34475	3

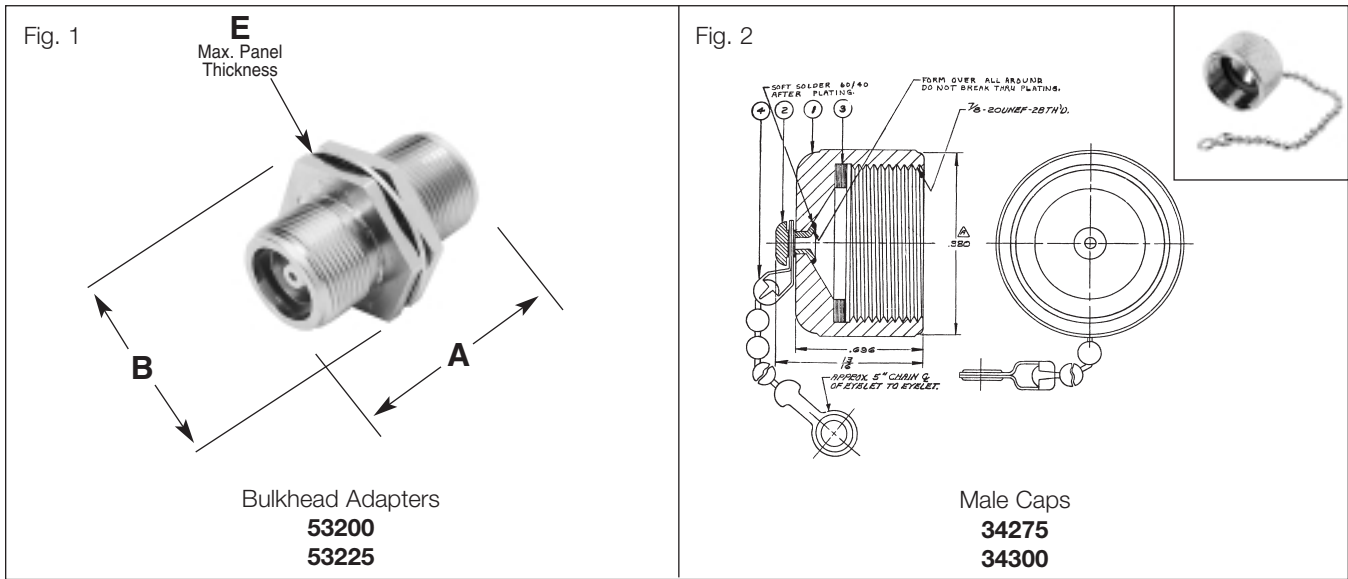

**BULKHEAD ADAPTERS**

Mating Threads	Dims. Inches (mm)						MTG Hole	PLT	Ins.	Amphenol Number	Fig
	a	b	c	d	e	f					
7/8-20	1.75 (44.5)	1.25 (31.8)	—	—	.709 (18.0)	—	.875 (22.2)	P1	D1	53200	1
11/16-24	1.75 (44.5)	.937 (23.8)	—	—	.709 (18.0)	—	.689 (17.5)	P1	D1	53225	1

**MALE CAPS**

Mating Threads	Dims. Inches (mm)						MTG Hole	PLT	Ins.	Amphenol Number	Fig
	a	b	c	d	e	f					
7/8-20	.813 (20.6)	1.00 (25.4)	.144 (3.66)	—	5.00 (127)	—	—	P3	—	34275	2
11/16-24	.781 (19.8)	.813 (20.6)	.144 (3.66)	—	5.00 (127)	—	—	P3	—	34300	2



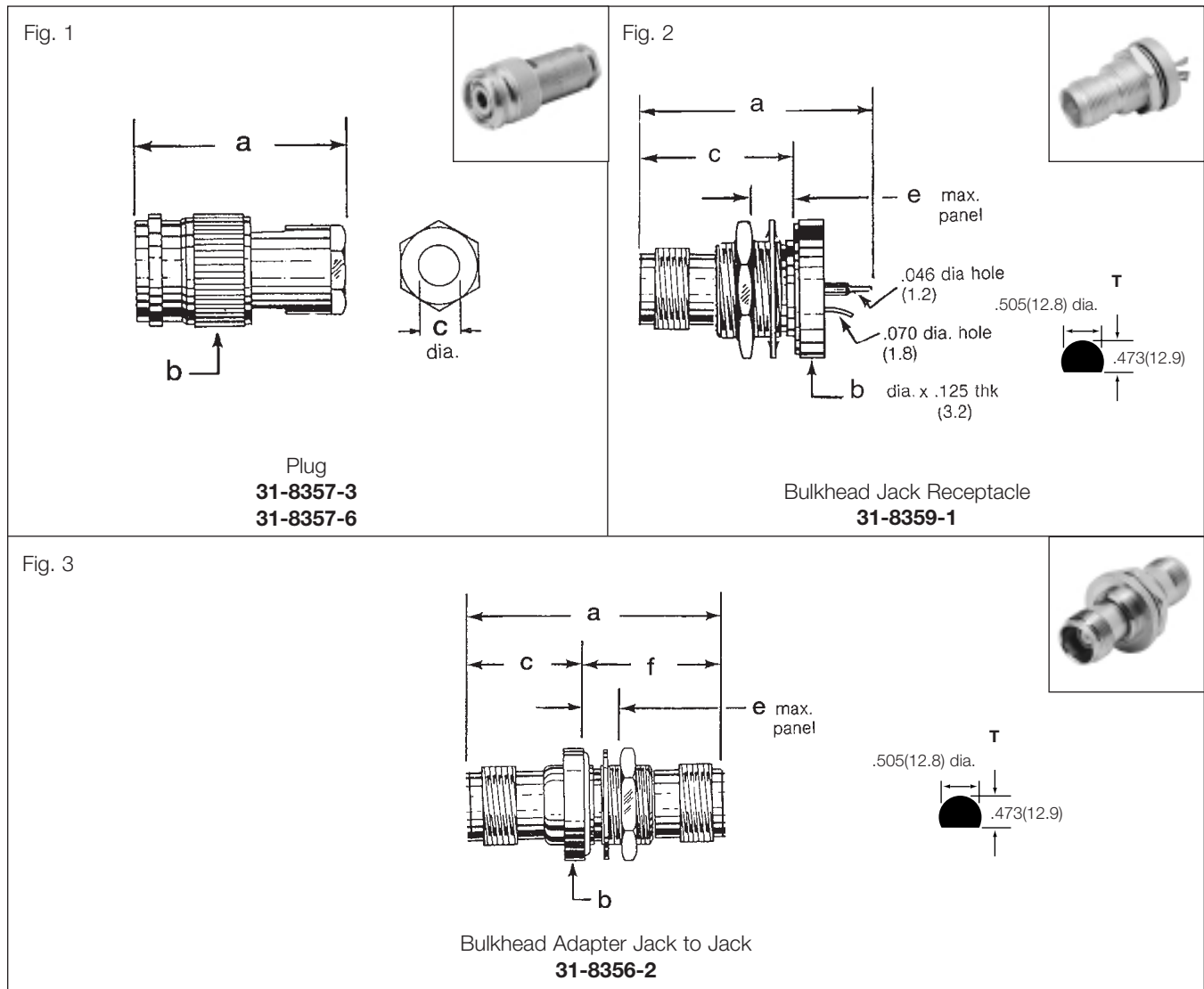

**PLUGS - MALE CONTACTS**

Triax Cable	Config.	Dims. Inches (mm)					MTG Hole	CAI	PLT	Ins.	Amphenol Number	Fig
		a	b	c	e	f						
Raychem 9530-D-5117	Plug	1.43 (36.3)	.625 (15.9)	.177 (4.5)	—	—	—	C13	P15	D1	31-8357-3	1
Times TBF-58	Plug	1.43 (36.3)	.625 (15.9)	.257 (6.5)	—	—	—	C13	P33	D1	31-8357-6	1

**RECEPTACLES - FEMALE CONTACTS**

Description	Config.	Dims. Inches (mm)					MTG Hole	CAI	PLT	Ins.	Amphenol Number	Fig
		a	b	c	e	f						
Bulkhead Jack Receptacle	Recep.	1.20 (30.5)	.690 (17.5)	.825 (21.0)	.250 (6.4)	—	T	—	P33	D1	31-8359-1	2

**ADAPTER**

Description	Config.	Dims. Inches (mm)					MTG Hole	CAI	PLT	Ins.	Amphenol Number	Fig
		a	b	c	e	f						
Bulkhead Jack to Jack	Adapter	1.37 (34.8)	.730 (18.5)	.638 (16.2)	.187 (4.7)	.737 (1.87)	T	—	—	—	31-8356-2	3

- accommodates cable diameter

# Notes

Series of horizontal dashed lines for taking notes.

**Description**

UHF - Invented in the 1930's by an Amphenol engineer, E. Clark Quackenbush, for use in the radio industry.

UHF coaxial connectors are general purpose units developed for use in low frequency systems from 0.6 to 300 MHz.

UHF is an acronym for "Ultra High Frequency". When the UHF was introduced, 300 MHz was considered High Frequency.

The coupling on a UHF is threaded.

Since UHF connectors are low cost, the impedance is variable.

**Features/Benefits**

- Optional reducing adapters accommodates a wide range of popular coaxial cables.
- Solder termination types require no special assembly tools.
- Crimp termination type connector available provides a lower cost installation method.
- Large size threaded coupling - rugged design.
- Non-demanding specifications and low cost.

**Applications**

- Antennas
- Cable Assemblies
- CB Radios
- Low Frequency Applications
- Public Address Systems

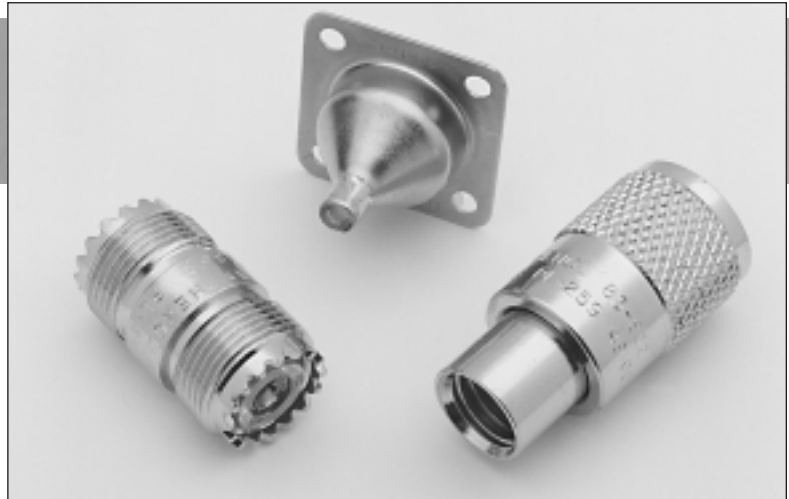

**UHF**

Specifications	186
Plugs, Reducing Adapters	187-188
Receptacles	189
Adapters/Hoods	190
Cap & Chain	191

### ELECTRICAL

Impedance	Non-constant
Frequency range	0-300MHz
Voltage rating	500 volts peak

### MECHANICAL

Mating	5/8-24 threaded coupling
Cable affixment	Braid solder, set screw, clamp and crimp

### ENVIRONMENTAL

Temperature range	Mica-filled phenolic insulators: - 55°C to + 149°C Copolymer of styrene and polystyrene: - 55°C to + 85°C TFE insulators: - 65°C to + 165°C
Weatherproof	Except as noted, all series UHF are non-weatherproof

### MATERIAL

Contacts	Male: brass; silver plated Female: beryllium copper, silver plated
Bodies	Brass and die cast zinc
Other metal parts	Brass
Plating	Nickel and silver
Insulators	TFE, copolymer of styrene, polystyrene, mica-filled phenolic and PBT polyester or equal

NOTE: These characteristics are typical and may not apply to all connectors.

### PLUG

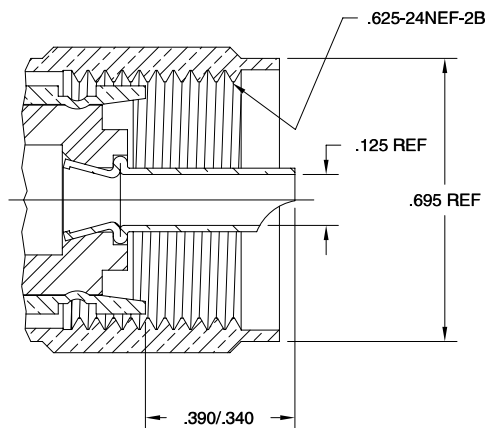

### JACK

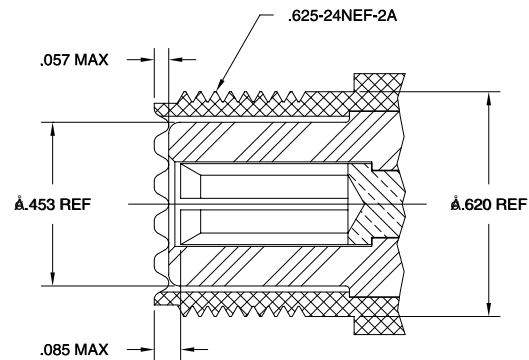

OR

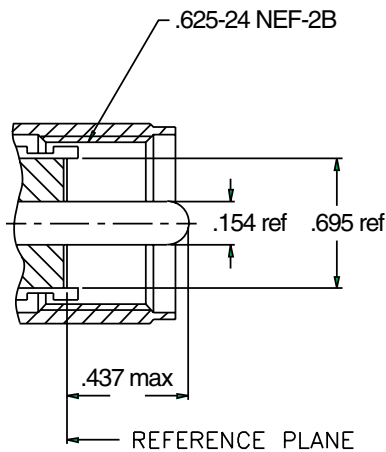

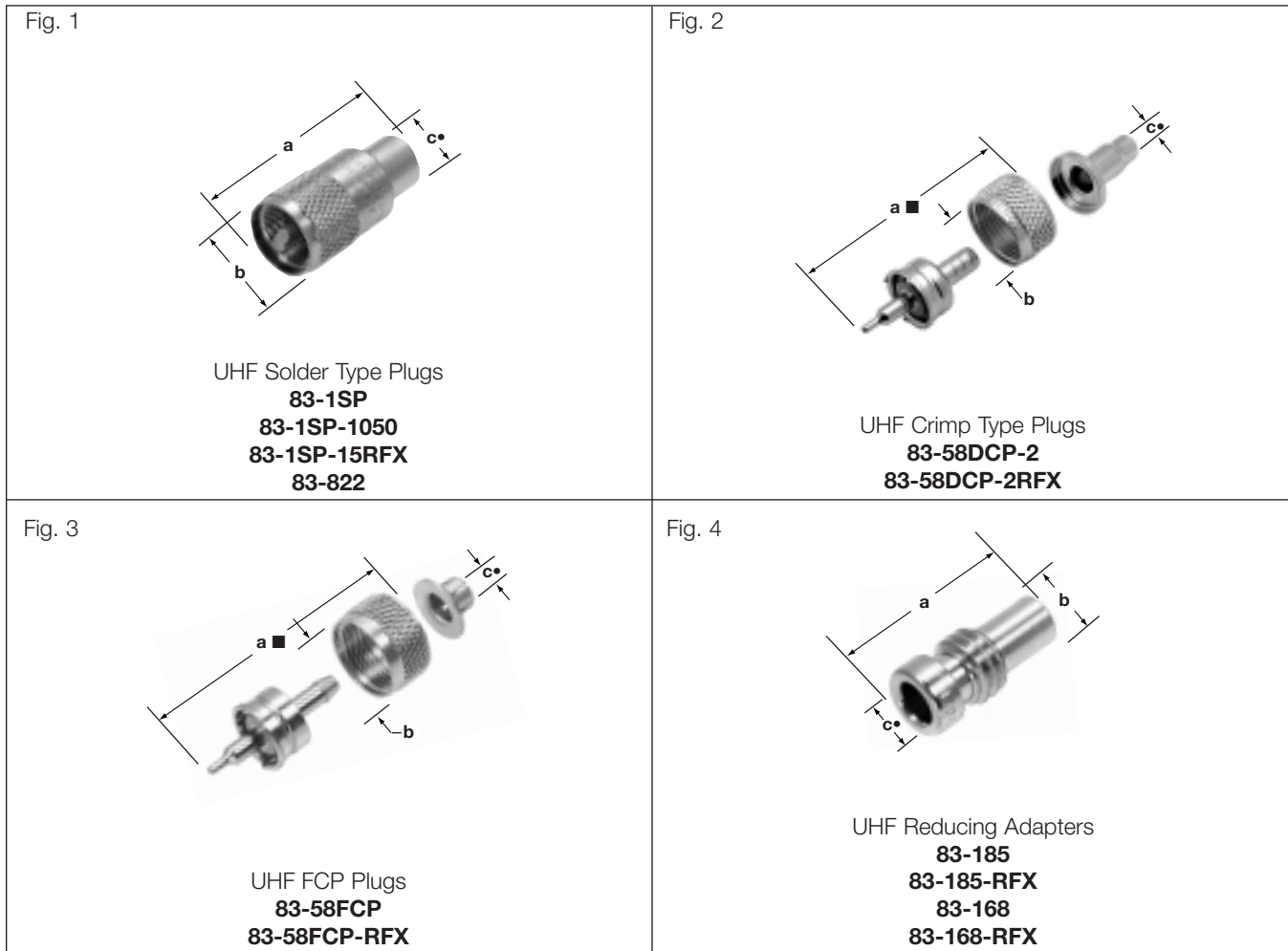

## UHF CABLE PLUGS, REDUCING ADAPTERS

Cable RG-/U	Conn Type	Cable Attachment		Dimensions, inches (millimeters)			Construction Notes				Military Number	Amphenol Number	Fig.
		Outer	Inner	a	b	c •	CAI	Plt.	Ins.	Other			
<b>8, 9, 11, 13, 63, 87A, 149, 213, 214, 216, 225</b>	Plug	Solder	Solder	1.50(38.0)	.750(19.0)	.444(11.3)	C1, C2	P4	D3	—	PL-259	<b>83-1SP</b>	1
	Plug	Solder	Solder	1.50(38.0)	.750(19.0)	.444(11.3)	C1, C2	P1	D30	IBM 460147	PL-259	<b>83-1SP-1050</b>	1
	Plug	Solder	Solder	1.50(38.0)	.750(19.0)	.420(10.7)	C1, C2	P1	D24	—	—	<b>83-1SP-15RFX</b>	1
	Plug	Solder	Solder	1.50(38.0)	.750(19.0)	.444(11.3)	C1, C2	P1	D1	TFE Insulation	PL-259	<b>83-822</b>	1
<b>58, 141</b>	Plug	Crimp	Crimp	1.41(35.7)■	.750(19.0)	.245(6.2)	C5	P2	D2	—	—	<b>83-58DCP-2</b>	2
	Plug	Solder	Crimp	1.38(35.1)	.716(18.2)	.212(5.4)	C5	P1	D24	—	—	<b>83-58DCP-2RFX</b>	2
	Plug	FCP	Pliers	1.06(27.0)■	.750(19.0)	.195(4.9)	C6	P2	D2	No Soldering	—	<b>83-58FCP □</b>	3
	Plug	FCP	Pliers	1.16(29.4)■	.716(18.2)	.224(5.7)	C6	P7	D24	No Soldering	—	<b>83-58FCP-RFX</b>	3
<b>59, 62, 140, 210</b>	Plug	Solder	Solder	1.68(42.9)	.781(19.8)	.257(6.6)	C2	P1	D30	—	UG-111/U	<b>83-750</b>	1
				1.00(25.4)	.438(11.1)	.209(5.3)	C2	P3	—	—	UG-175/U	<b>83-185</b>	4
Reducing Adapter For use on RG-55, 58, 141, 142 Cable (Except 55A)				1.00(25.4)	.437(11.1)	.209(5.3)	C2	P3	—	—	—	<b>83-185-RFX</b>	4
Reducing Adapter For use on RG-59, 62, 71, 140, 210 Cable				1.00(25.4)	.438(11.1)	.257(6.5)	C2	P3	—	—	UG-176/U	<b>83-168</b>	4
				1.00(25.4)	.437(11.1)	.257(6.5)	C2	P3	—	—	—	—	<b>83-168-RFX</b>

• accommodates cable diameter ▲ distributor stocked ■ includes outer ferrule □ US patent 4,053,200

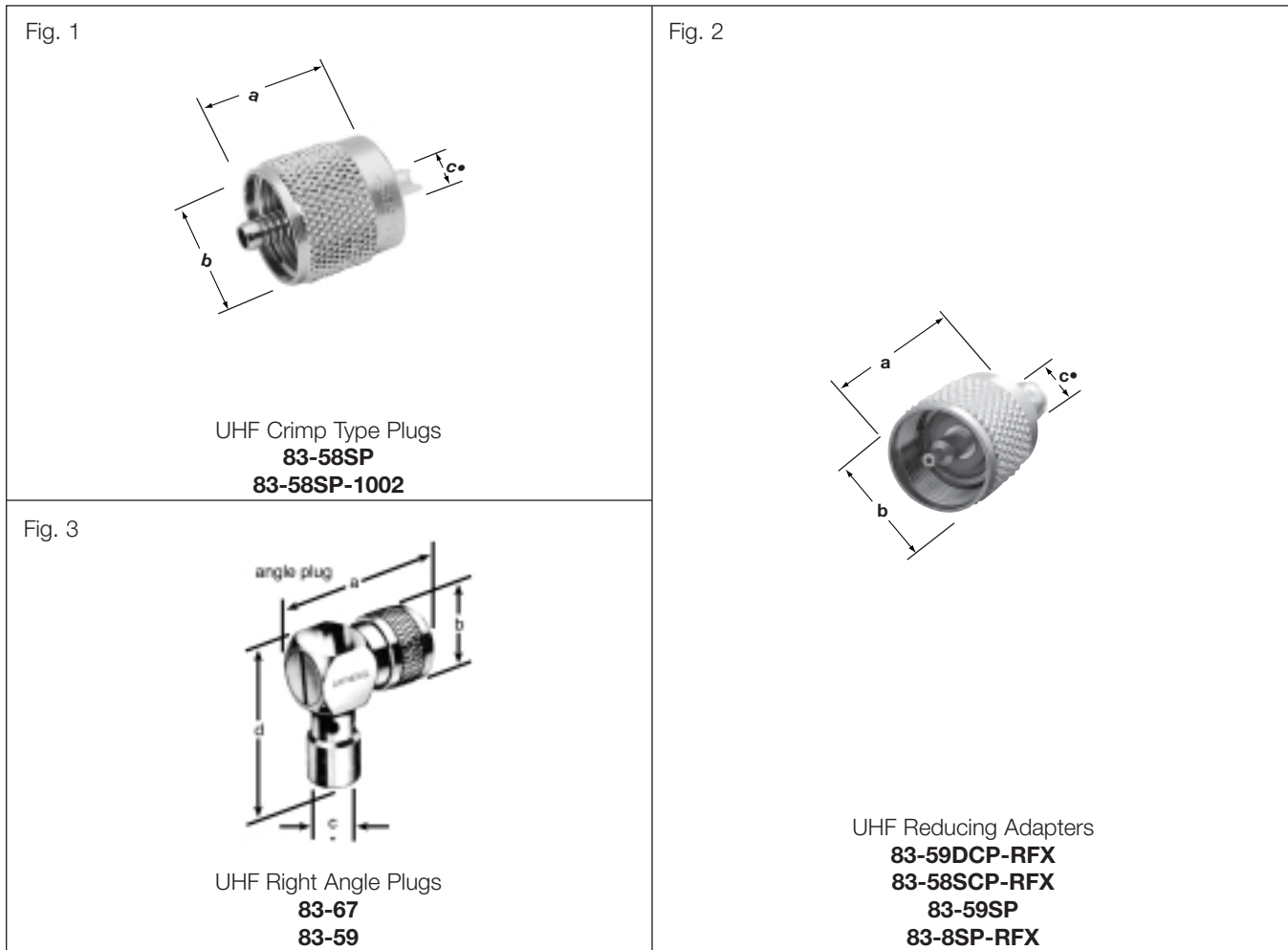

## UHF CABLE PLUGS, REDUCING ADAPTERS

Cable RG-/U	Conn Type	Cable Attachment		Dimensions, inches (millimeters)			Construction Notes				Military Number	Amphenol Number	Fig.
		Outer	Inner	a	b	c •	CAI	Pit.	Ins.	Other			
58, 142	Plug	Crimp	Solder	1.31(33.3)■	.750(19.0)	.206(5.3)	C4	P1	D30		—	83-58SP	1
400	Plug	Crimp	Solder	1.31(33.3)	.750(19.0)	.206(5.3)	C4	P1	D1	Teflon Insulation	—	83-58SP-1002	1
59	Plug	Crimp	Solder	1.39(35.4)	.716(18.2)	.257(6.6)	C4	P1	D24		—	83-59DCP-RFX	2
58	Plug	Crimp	Solder	1.39(35.4)	.716(18.2)	.206(5.3)	C4	P1	D24		—	83-58SCP-RFX	2
59	Plug	Crimp	Solder	1.39(35.4)	.716(18.2)	.257(6.6)	C4	P1	D3		—	83-59SP	2
8	Plug	Crimp	Solder	1.39(35.4)	.716(18.2)	.429(10.9)	C4	P1	D24		—	83-8SP-RFX	2
8, 9, 11, 13, 63, 87A, 149, 213, 214, 216, 225	R/A Plug	Solder	Solder	1.37(34.9)	.750(19.0)	.444(11.3)	C1	P1	D1	Teflon Insulation	—	83-67	3
	R/A Plug	Solder	Solder	1.37(34.9)	.750(19.0)	.444(11.3)	C1	P1	D6	Styrene Insulation	—	83-59	3

• accommodates cable diameter ▲ distributor stocked ■ includes outer ferrule □ US patent 4,053,200

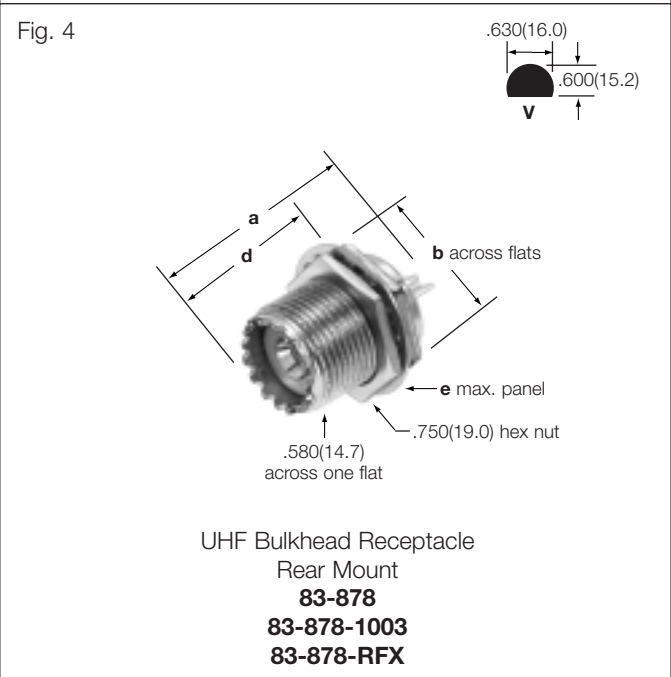
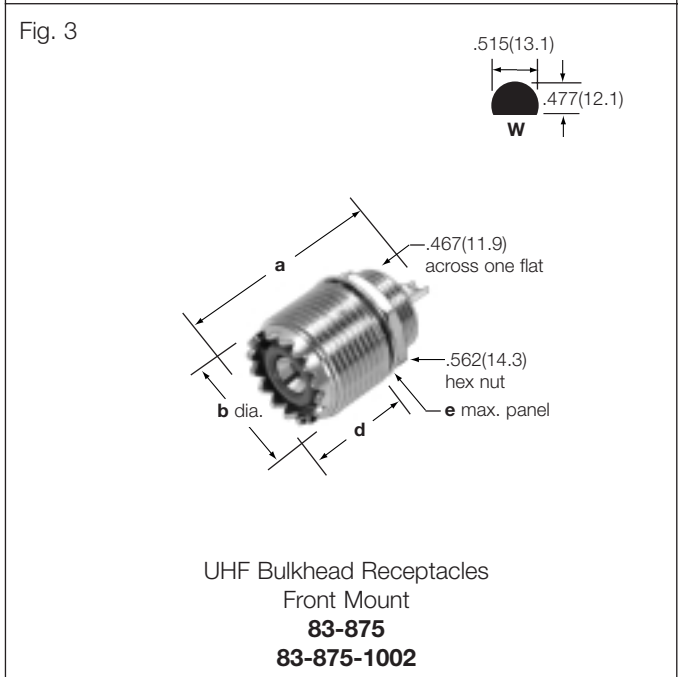
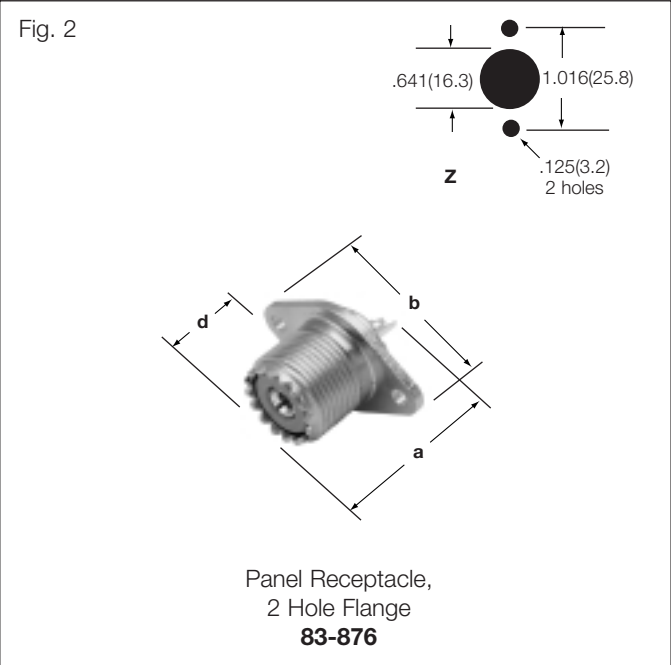
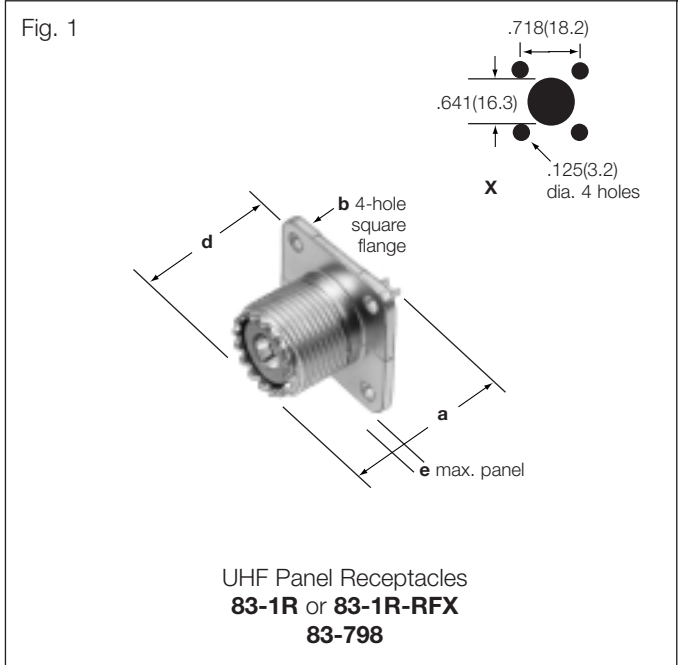

## UHF PANEL & BULKHEAD RECEPTACLES

Description	Dimensions, inches (millimeters)				Plt.	Ins.	Mtg. Hole	Military Number	Amphenol Number	Fig.
	a	b	d	e						
Panel Receptacle, Solder Cup 4-hole Square Flange	1.05(26.8)	1.00(25.4)	.553(14.0)	.187(4.7) ▼	P1	D2	X	SO-239	<b>83-1R★</b>	1 ▲
Panel Receptacle, Solder Cup 4-hole Square Flange	1.06(27.0)	1.00(25.4)	.553(14.0)	.187(4.7) ▼	P1	D25	X	—	<b>83-1R-RFX★</b>	1 ▲
Panel Receptacle	1.05(26.8)	1.00(25.4)	.553(14.0)	.187(4.7) ▼	P1	D1	X	SO-239A	<b>83-798</b>	1 ▲
Panel Receptacle, Oval Flange	1.05(26.8)	1.30(32.9)	.553(14.0)	.187(4.7) ▼	P1	D2	Z	—	<b>83-876</b>	2 ▲
Bulkhead Receptacle Front Mount	1.09(27.8)	.563(14.3)	.500(12.7)	.156(4.0)	P1	D1/D6	W	—	<b>83-875</b>	3 ▲
Front Mount Bulkhead Type; Solder Cup Term.	1.09(27.8)	.563(14.3)	.500(12.7)	.156(4.0)	P1	D1	W	—	<b>83-875-1002</b>	3 ▲
Rear Mount Bulkhead Type; Solder Cup Term.	1.06(27.0)	.750(19.1)	.590(15.0)	.187(4.7)	P1	D2	V	—	<b>83-878</b>	4 ▲
Rear Mount Bulkhead Type; Solder Cup Term.	1.06(27.0)	.750(19.1)	.590(15.0)	.187(4.7)	P1	D1	V	—	<b>83-878-1003</b>	4 ▲
Rear Mount Bulkhead Type; Solder Cup Term.	1.06(27.0)	.750(19.1)	.590(15.0)	.187(4.7)	P1	D1	V	—	<b>83-878-RFX</b>	4 ▲

★ IBM 317228 ▼ max. panel when rear mounted thru panel ▲ Distributor stocked



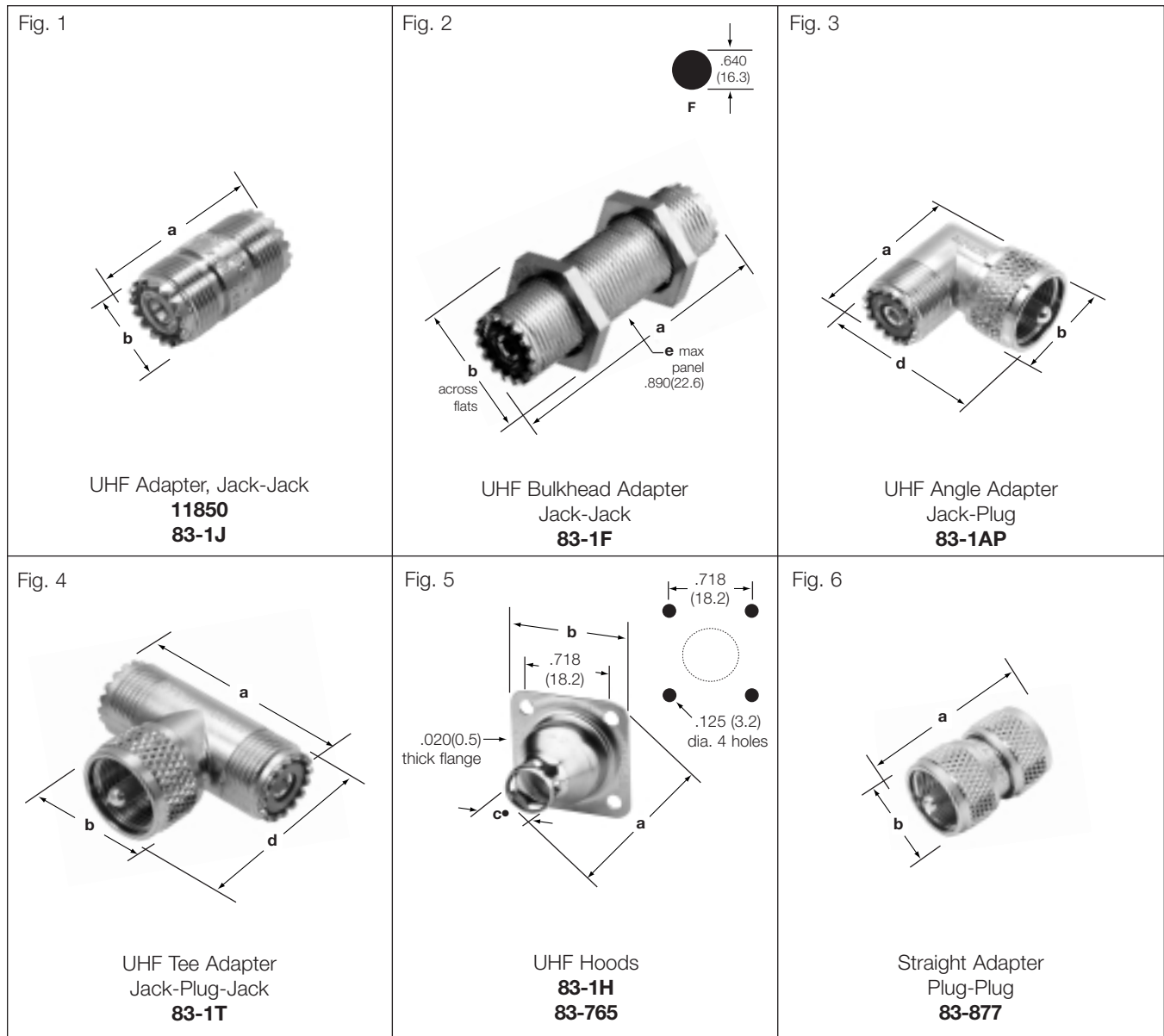

## UHF IN-SERIES ADAPTERS, HOODS

Description	Dimensions, inches (millimeters)				CAI	Plt.	Ins.	MTG Hole	Military Number	Amphenol Number	Fig.
	a	b	c •	d							
Straight Adapter/Jack-Jack	1.12(28.6)	.625(15.9)	—	—	—	P1	D1	—	PL-258	11850	1
Straight Adapter/Jack-Jack	1.12(28.6)	.625(15.9)	—	—	—	P1	D5	—	PL-258	83-1J	1 ▲
Bulkhead Adapter/Jack-Jack	2.00(50.8)	.625(15.9)	—	—	—	P1	D5	F	UG-363/U	83-1F	2 ▲
Angle Adapter/Jack-Plug	1.28(32.5)	.750(19.1)	—	1.19(30.2)	—	P1	D5	—	UG-646/U	83-1AP	3 ▲
Tee Adapter/Jack-Plug-Jack	1.63(41.3)	.750(19.1)	—	1.20(30.6)	—	P1	D5	—	M-358	83-1T	4 ▲
Hood/4-hole flange mount/Adapts Panel Receptacle 83-1R to RG-8,10,11,12,63,79,115,149,213,215	.750(19.1)	1.00(25.4)	.345(8.8)	—	C7	P3	—	—	UG-106/U	83-1H	5 ▲
Hood/4-hole flange mount/Adapts Panel Receptacle 83-1R to RG-58,141 cables	.750(19.1)	1.00(25.4)	.155(3.9)	—	C7	P3	—	—	UG-177/U	83-765	5 ▲
Straight Adapter/Plug-Plug	1.31(33.3)	.781(19.8)	—	—	—	P1	D5	—	PL-258	83-877	6

• accommodates cable diameter ▲ distributor stocked



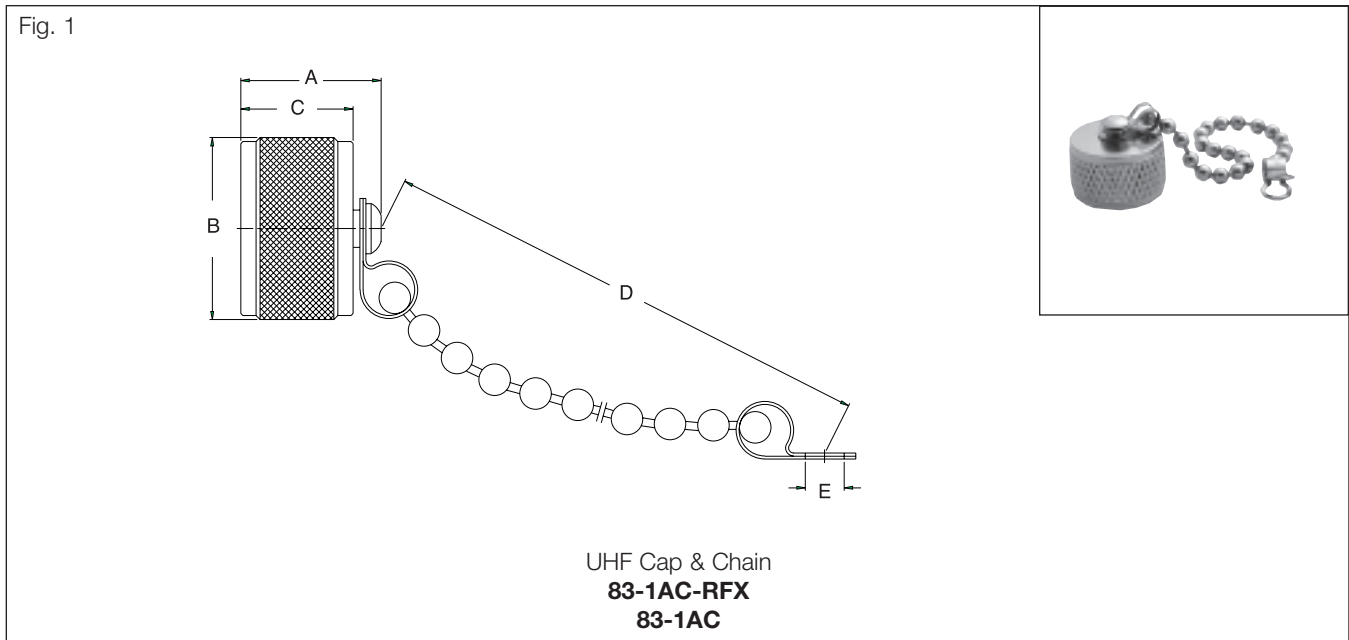

## UHF MALE CAP & CHAIN

Description	Dimensions, inches (millimeters)					CAI	PLT	Ins.	Amphenol Number	Fig.
	a	b	c •	d	e					
UHF Cap & Chain	.551 (14)	.717 (18.2)	.441 (11.2)	3.94 (10.0)	.154 (3.9)	—	P3	—	<b>83-1AC-RFX</b>	1
UHF Cap & Chain	.580 (14.7)	.750 (19.1)	.438 (11.1)	4.56 (115.9)	.130 (3.3)	—	P3	—	<b>83-1AC</b>	1

# Notes

Handwriting practice area consisting of 30 horizontal dotted lines.

**Description**

Mini-UHF are a miniature version of the UHF connectors invented in the 1930's for use in the radio industry. Mini-UHF connectors debuted in the 1970's.

Mini-UHF connectors are designed for use as coaxial interconnection in cellular mobile telephone systems and similar applications where size, weight and cost factors are critical.

These connectors terminate RG-58, -58A, -58B, -58C, and Belden 9258 cables.

Crimp-type cable plugs and jacks are available as well as panel and printed circuit board receptacles.

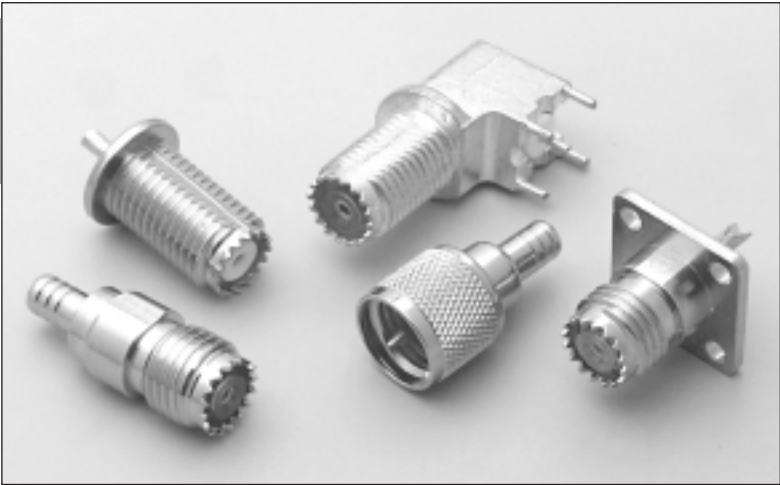

**Features/Benefits**

- Miniature 3/8-24 thread size provides excellent RF performance for applications up to 2.5 GHz.
- Small size and light weight provides excellent electrical characteristics at an affordable price.
- Crimp-type cable termination provides low installation cost.
- Diecast bodies and molded insulators ensures low cost.
- Teflon insulator provides higher temperature range.

**Applications**

- Antennas
- Automotive (Cell phones)
- Automotive (GPS)
- Cable Assembly
- Cable Modems
- Components
- PC/LAN
- Telecom

**Mini-UHF**

Specifications	194
Plugs, Jacks & Receptacles	195

### ELECTRICAL

Impedance	50 ohms
Frequency range	0-2.5 GHz
Voltage rating	335 volts at sea level
Dielectric withstanding voltage	1,000 volts rms.
VSWR	1.25 max., 0-2.5 GHz
Insulation resistance	5,000 megohms min.

### ENVIRONMENTAL

Temperature range	- 55°C to + 85°C
Shock	Per MIL-Std. 202
Vibration	Per MIL-Std. 202
Thermal shock	Per MIL-Std. 202
Salt spray	Per MIL-Std. 202

### MATERIAL

Plug coupling nuts and jack bodies	Brass or zinc alloy
Other metal parts	Brass
Insulator	Polypropylene
Plating	Contacts - Tin lead Other metal parts - Nickel

### MECHANICAL

Mating	3/8-24 threaded coupling
Cable affixment (braid)	Crimp
Cable affixment (center conductor)	Crimp
Cable retention	40 lb. min.

NOTE: These characteristics are typical and may not apply to all connectors.

### PLUG

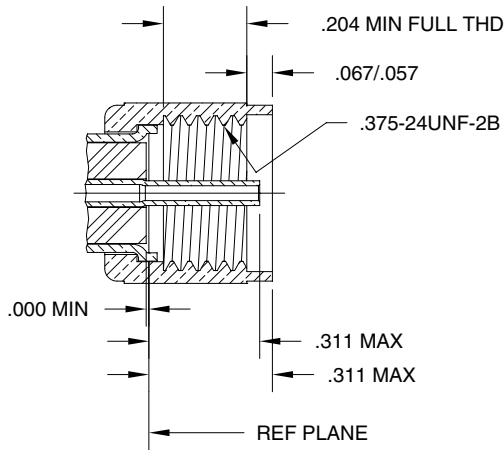

### JACK

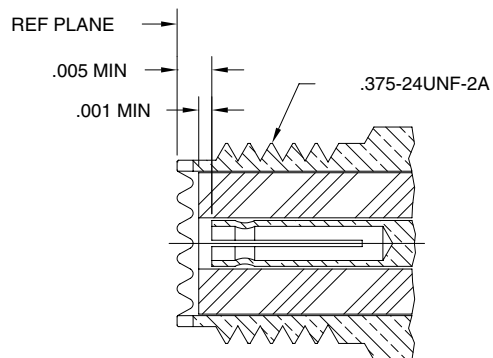

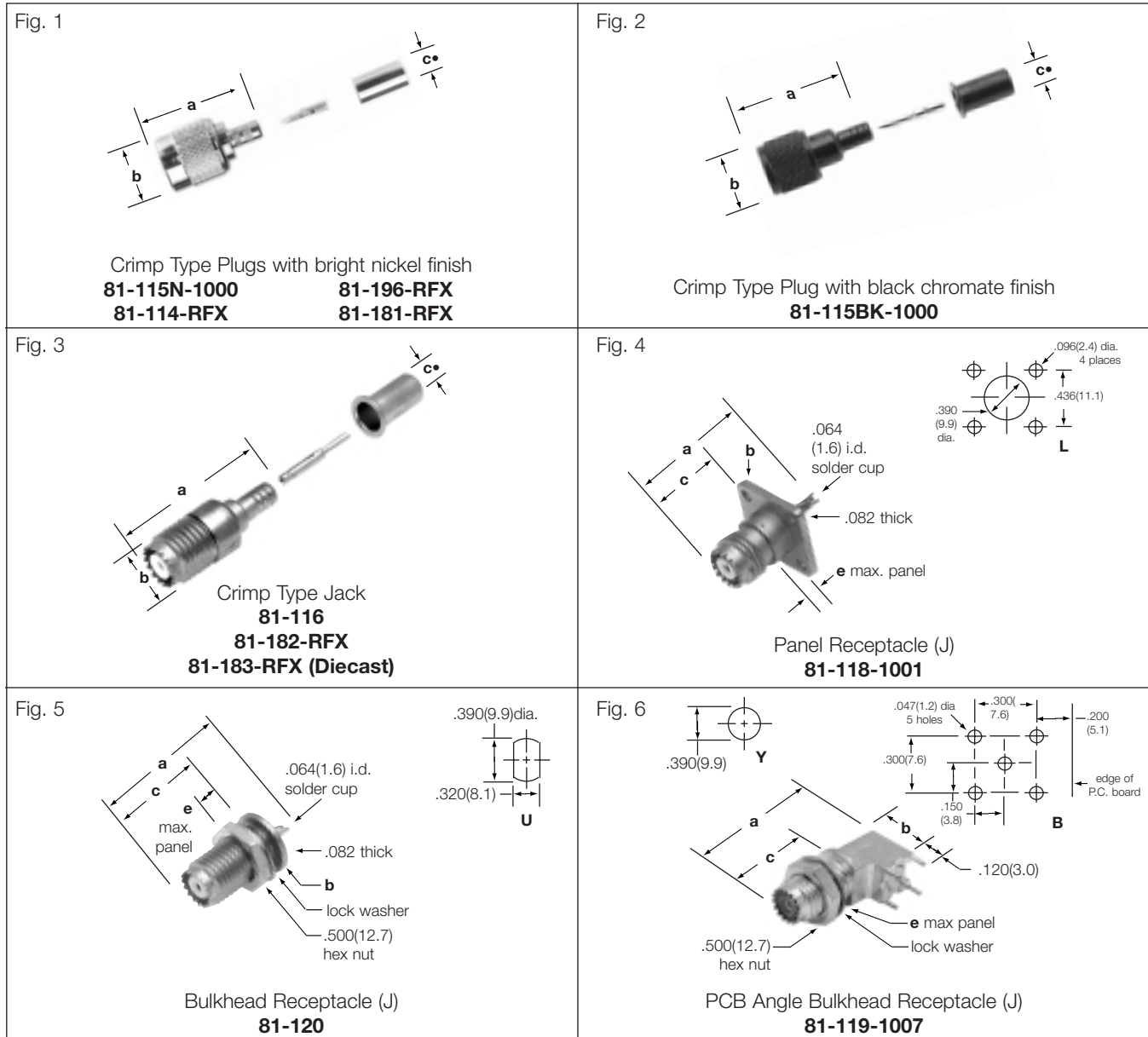

**MINI UHF PLUGS & JACKS**

Cable RG-/U	Conn. Type	Cable Attachment		Dimensions Inches (mm)			CAI	Pit.	Ins.	Amphenol Number	Fig.
		Outer	Inner	a	b	c •					
59	Jack	Crimp	Crimp	1.24(31.5) ■	.375(9.5)	.260(6.6)	C39	P15	D1	81-182-RFX	3 ▲
	Plug	Crimp	Crimp	1.14(28.9) ■	.453(11.5)	.260(6.6)	C39	P15	D23	81-181-RFX	1 ▲
58/U, 58 B/U	Plug	Crimp	Crimp	1.14(28.9) ■	.453(11.5)	.210(5.3)	C39	P15	D23	81-196-RFX	1 ▲
58	Plug	Crimp	Crimp	1.14(28.9) ■	.447(11.3)	.206(5.2)	C39	P35	D9	81-115N-1000	1 ▲
	Plug	Crimp	Crimp	1.14(28.9) ■	.447(11.3)	.206(5.2)	C39	P35	D9	81-115BK-1000	2 ▲
	Jack	Crimp	Crimp	1.17(29.7) ■	.375(9.50)	.206(5.2)	C39	P5	D14	81-116	3 ▲
	Jack	Crimp	Crimp	1.01(25.7) ■	—	—	C39	P15	D23	81-183-RFX	3 ▲
Belden 9258 8X Type	Plug	Crimp	Crimp	1.21(30.7) ■	.447(11.3)	.256(6.5)	C39	P15	D1	81-114-RFX	1 ▲

**MINI UHF RECEPTACLES**

Connector Type	Dimensions Inches (mm)				CAI	Pit.	Ins.	MTG Hole	Amphenol Number	Fig.
	a	b	c	e						
Panel Receptacle (J)	.925(23.5)	.625(15.9) sq	.487(12.4)	.187(4.7) ▼	—	P5	D14	L	81-118-1001	4
Bulkhead Receptacle (J)	.901(22.9)	.500(12.7) dia	.630(16.0)	.125(3.2)	—	P5	D14	U	81-120	5
PCB Angle Bulkhead Receptacle (J)	1.13(28.8)	.598(15.2)	.575(14.6)	.125(3.2)	—	P36	D1/26	Y/B	81-119-1007	6

• accommodates cable diameter ▲ distributor stocked ▼ max. panel when rear mounted thru panel ■ includes outer ferrule



**Description**

Amphenol C connectors are medium size and weatherproof. Coupling is two-stud bayonet lock. C connectors provide constant 50 ohm impedance. They may be used with 75 ohm cable, at lower frequencies (below 300 MHz) where no serious mismatch is introduced.

Amphenol HN connectors are medium size weatherproof units designed for high voltage applications. HN connectors feature captivated contact design which prevents contact recession under temperature extremes and mechanical stresses. Coupling is 3/4-20 threaded.

Amphenol SC connectors are medium size, constant 50 ohm impedance units manufactured to meet MIL-C-39012 category D, Specification sheets 35 through 43, meeting all of the mechanical and electrical requirements of the Limited Co-ordination Specification (LC Spec.) as generated by the U.S. Air Force.

Connector mating is a .687-24 UNEF screw thread.

**Features/Benefits**

- C — two-stud bayonet lock allows quick & easy coupling.
- HN — 3/4-20 thread withstands rugged applications.
- SC — MIL qualified per M39012 provides consistent performance and dependability.

**Applications**

- Instrumentation
- Cable Assemblies
- Components
- MIL Aerospace
- Airframe
- Test & Measurement



<b>C</b>	
Specifications	198
Plugs & Jacks	199
<b>HN</b>	
Specifications	200
Plugs & Jacks	201
Receptacles & Adapters	202
<b>SC</b>	
Specifications	203
Plugs & Jacks	204

## ELECTRICAL

Impedance	50 Ohm constant
Frequency range	0-11 GHz, 1500 V typ.
Voltage Rating 1500 x .707 (1060 rms)	1500 volts peak, std.
Dielectric Withstanding	3000 volts RMS
Voltage VSWR	1500 volt type; 1.35 max. to 11 GHz max. 2 Amps current @ 100 MHz @ 1500 volts peak

## ENVIRONMENTAL

Temperature range	-65°C to +165°C
Weatherproof	Except as noted, all C series connectors are weatherproof
Hermetic Seals	Pass helium leak test of $2 \times 10^{-8}$ c/sec
Pressurized	Compression seal

## MECHANICAL

Mating	2-stud Bayonet lock
Cable affixment	Braid clamp

## MATERIAL

Contacts	Male: brass Female & Outer beryllium copper. Silver plated except M39012 gold.
Other metal parts	Brass: ASTROplate® finish except M39012 silver
Insulators	TFE, glass-TFE (hermetically sealed)
Weatherproof gaskets	Silicone rubber

## MILITARY SPECIFICATIONS

MIL-C-39012 & MIL-A-55339	where applicable
------------------------------	------------------

NOTE: These characteristics are typical and may not apply to all connectors.

## PLUG

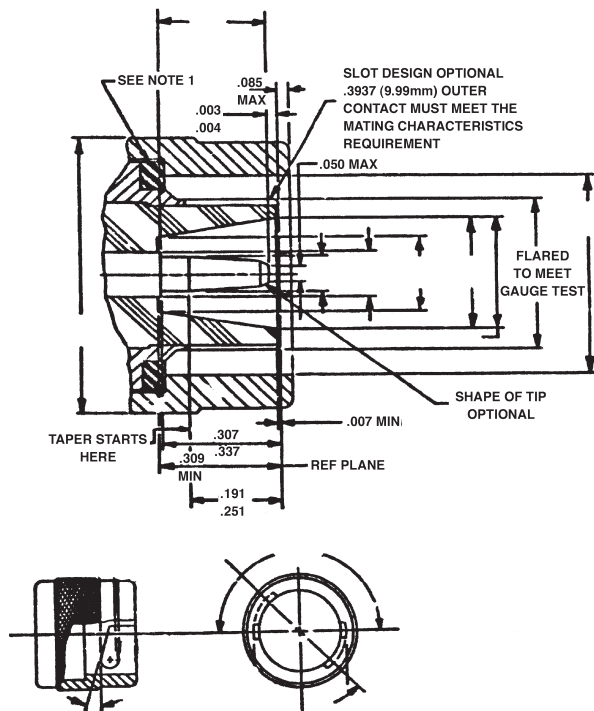

## JACK

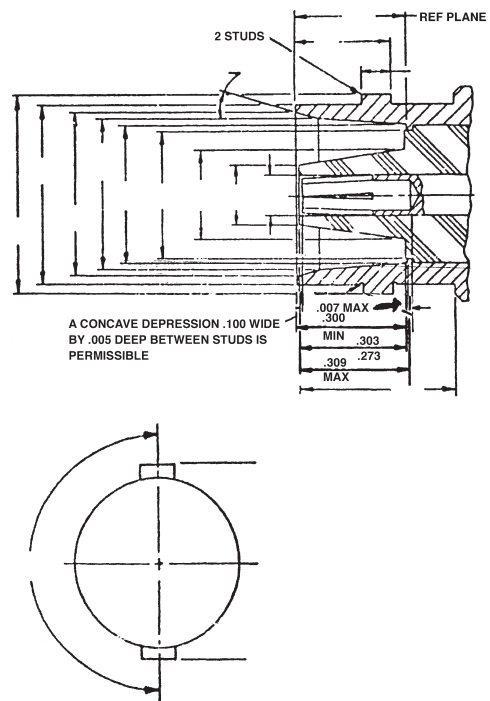



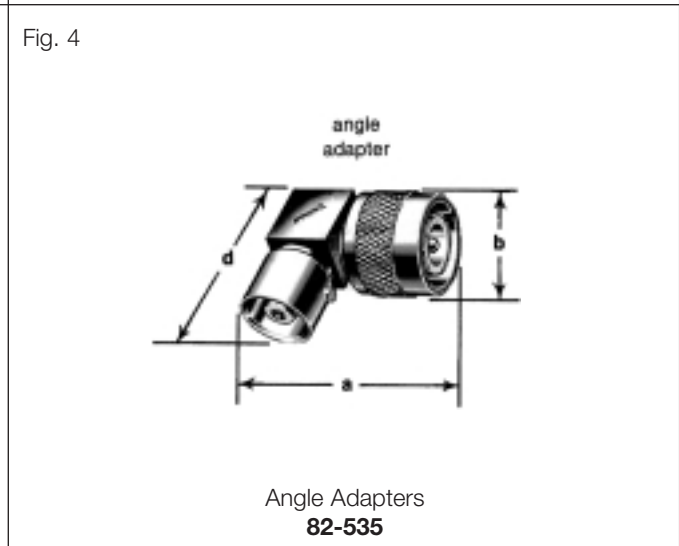
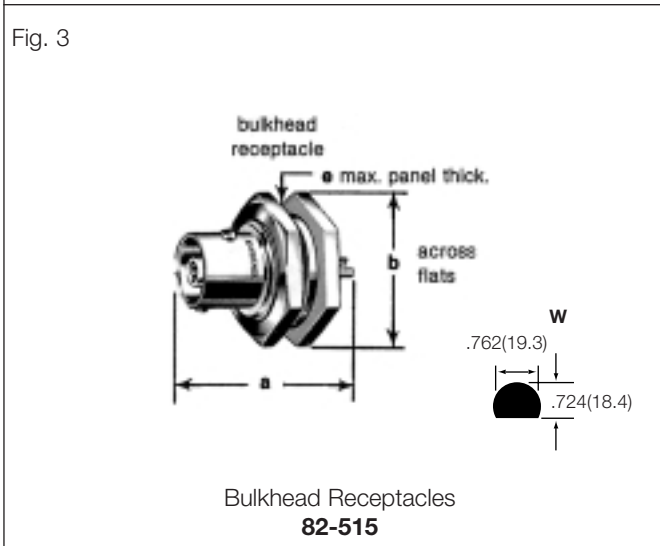
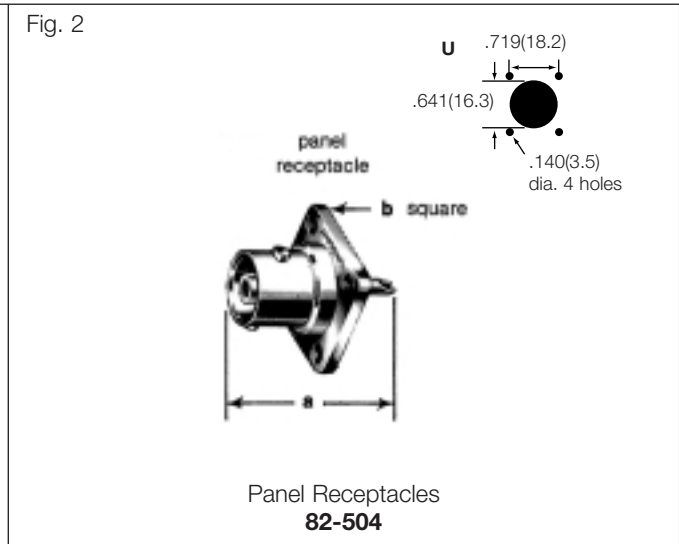
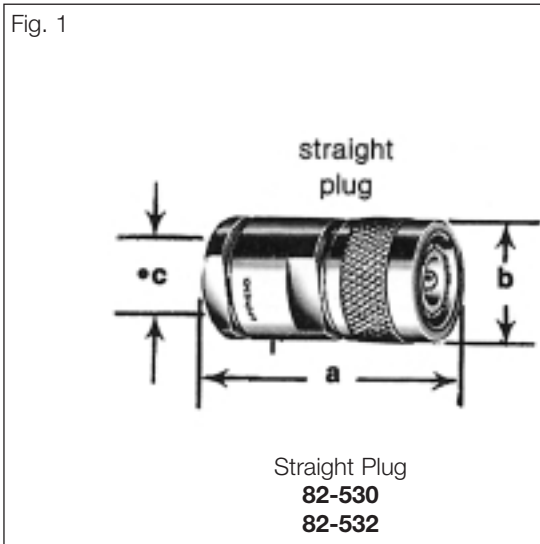

## STRAIGHT PLUGS

Cable RG-/U	Dimensions, inches (millimeters)					Construction Notes			Military Number	Amphenol Number	Fig
	a	b	c	d	e	CAI	Pit.	Ins.			
8, 9, 87A, 213, 214, 225	1.48 (37.7)	.750 (19.1)	.444 (11.3)	—	—	C16	P1	D1	UG-573A	<b>82-530</b>	1
	1.75 (44.5)	.750 (19.1)	.444 (11.3)	—	—	C16	P1	D1	UG-628A (4000 V Peak)	<b>82-532</b>	1

## PANEL RECEPTACLES

Description	Dimensions, in. (mm)				MTG Hole	Construction Notes			Military Number	Amphenol Number	Fig
	a	b	d	e		CAI	Pit.	Ins.			
#6-32 tapped flange holes/female contacts	1.09 (27.8)	1.00 (25.4)	—	—	U	—	P1	D1	UG-568	<b>82-504</b>	2
4000 volts peak	1.31 (33.3)	1.00 (25.4)	—	1.56 (4.0)	W	—	P1	D1	UG-634	<b>82-515</b>	3

## ANGLE ADAPTER

Description	Dimensions, in. (mm)				MTG Hole	Construction Notes			Military Number	Amphenol Number	Fig
	a	b	d	e		CAI	Pit.	Ins.			
Jack-plug/non-weatherproof	1.25 (31.8)	.766 (19.4)	1.25 (31.8)	—	—	—	P4	D1	UG-567A	<b>82-535</b>	4

## ELECTRICAL

Impedance	50 Ohms
Frequency range	0-4 GHz
Voltage Rating	1500 volts peak, std.
Dielectric Withstanding Voltage	5000 volts RMS

## ENVIRONMENTAL

Temperature range	TFE -65°C to +165°C Copolymer of styrene: -55°C to +85°C
Weatherproof	All HN Series are weatherproof
Hermetic Seals	Pass helium leak test of $2 \times 10^{-8}$ cc/sec
Pressurized	Compression Seal

## MECHANICAL

Mating	3/4-20 threaded coupling
Cable affixment	Screw-thread nut and braid clamp

## MATERIAL

Contacts	Male: brass Female: beryllium copper. Outer: brass Finish: silver or gold
Other metal parts	Brass: ASTROplate® finish
Insulators	TFE, glass-TFE Copolymer of styrene: (hermetically sealed)
Weatherproof gaskets	Silicone rubber; Synthetic rubber

NOTE: These characteristics are typical and may not apply to all connectors.

## PLUG

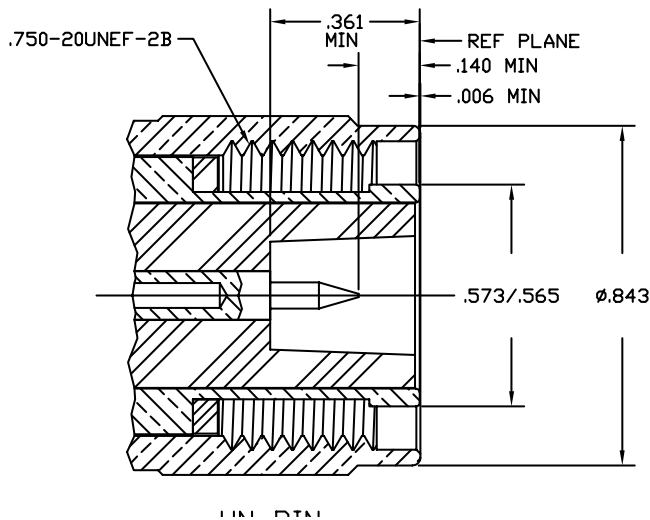

## JACK

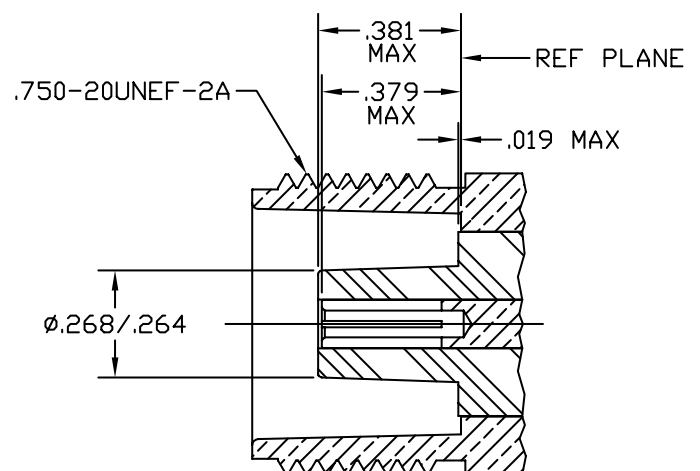

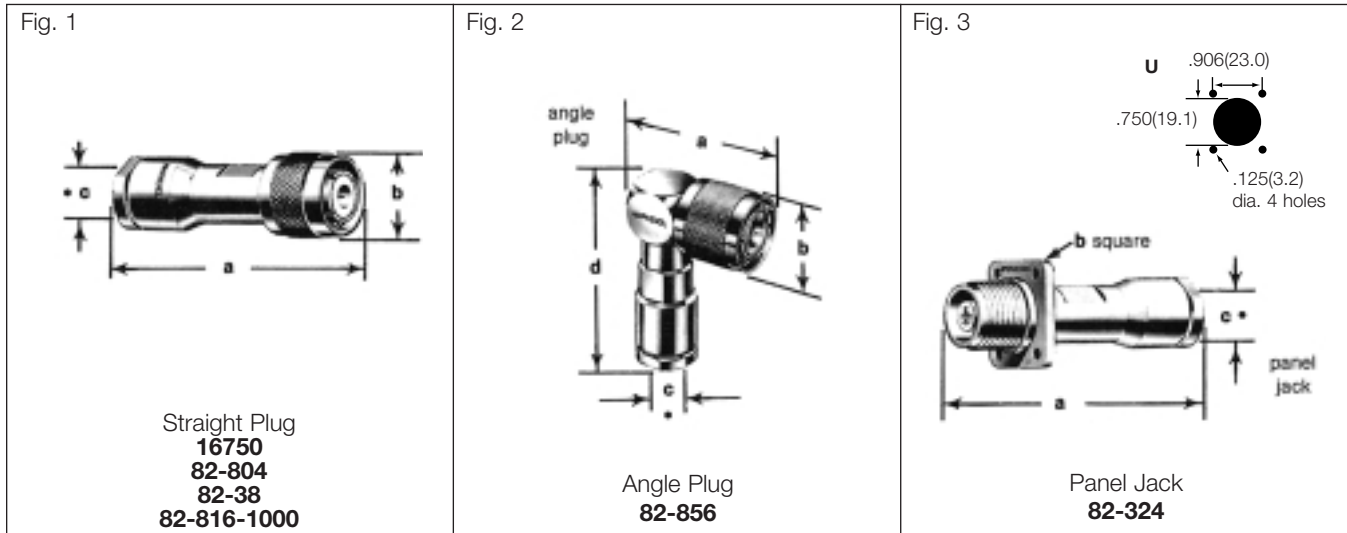

## STRAIGHT PLUGS

Description	Cable Termination	Dimensions, in. (mm)				MTG Hole	Construction Notes			Military Number	Amphenol Number	Fig
		a	b	c	d		CAI	Pit.	Ins.			
58, 141, 142	TYP-Clamp	1.81 (46.0)	.844 (21.4)	.214 (5.4)	—	—	C18	P1	D1	—	16750	1
8, 9, 213, 214	TYP-Clamp	2.38 (60.3)	.875 (22.2)	.444 (11.3)	—	—	C20	P1	D6	UG-59A	82-38	1
54A	TYP-Clamp	1.81 (46.0)	.875 (22.2)	.257 (6.5)	—	—	C18	P4	D6	—	82-816-1000	1
8, 9, 87A, 213, 214, 225	TYP-Clamp	2.38 (60.3)	.875 (22.2)	.444 (11.3)	—	—	C17	P1	D1	UG-59B	82-804	1

## ANGLE PLUG

Description	Cable Termination	Dimensions, in. (mm)				MTG Hole	Construction Notes			Military Number	Amphenol Number	Fig
		a	b	c	d		CAI	Pit.	Ins.			
8, 9, 87A, 213, 214, 225	TYP-Clamp	1.50 (38.1)	.875 (22.2)	.444 (11.3)	2.31 (58.7)	—	C17	P1	D1	—	82-856	2

## PANEL JACKS

Description	Cable Termination	Dimensions, in. (mm)				MTG Hole	Construction Notes			Military Number	Amphenol Number	Fig
		a	b	c	d		CAI	Pit.	Ins.			
8, 9, 87A, 213, 214, 225	C.C.-Clamp	2.94 (74.6)	1.19 (30.2)	.444 (11.3)	—	U	C17	P1	D1	UG-1215	82-324	3

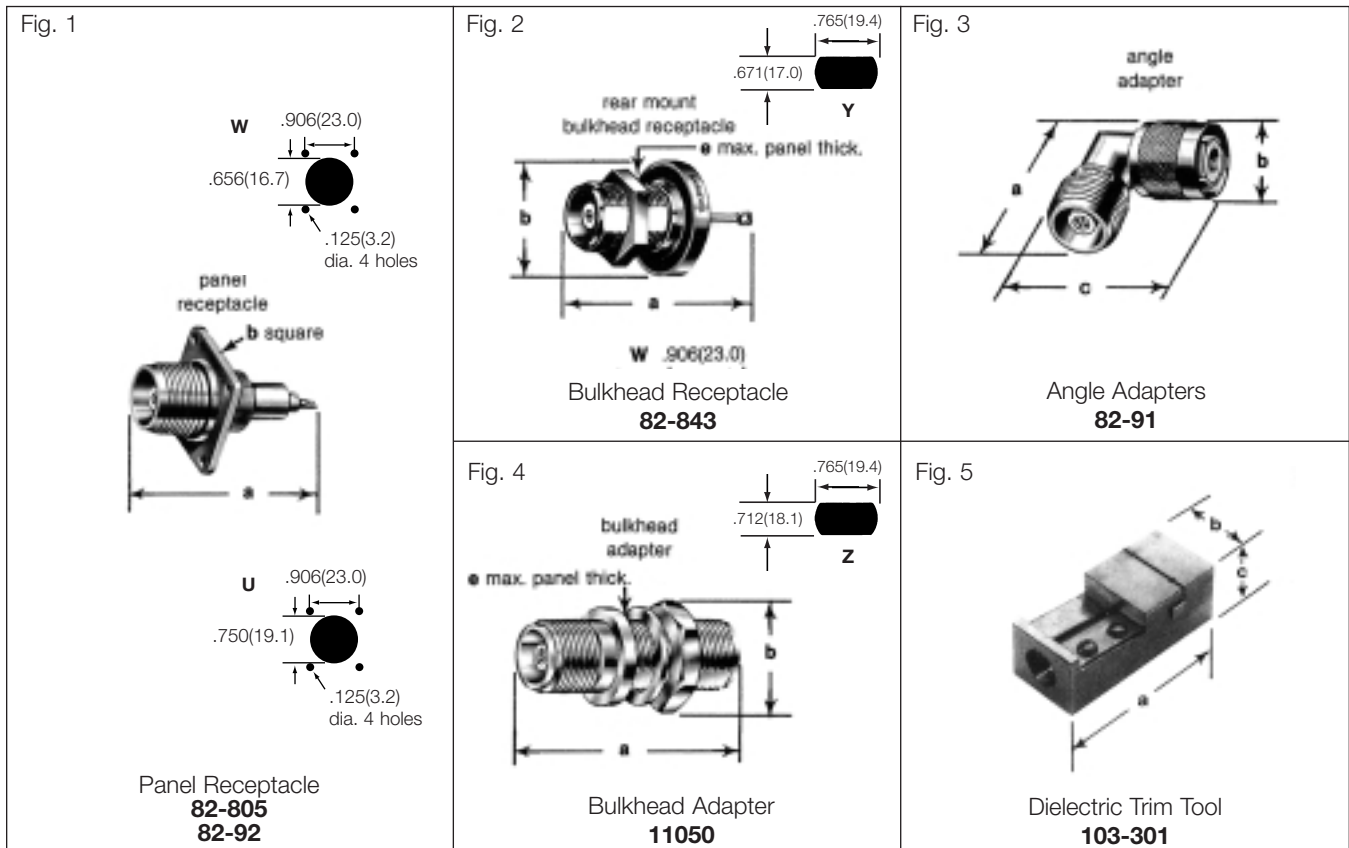

## PANEL RECEPTACLES

Description	Dimensions, in. (mm)				MTG Hole	Construction Notes			Military Number	Amphenol Number	Fig
	a	b	c	e		CAI	Plt.	Ins.			
Solder Cup Terminal	1.88 (47.6)	1.19 (30.2)	—	—	W	—	P1	D1	UG-560	82-805	1
Solder Cup Terminal (Copolymer Styrene Ins.)	1.53 (38.9)	1.19 (30.2)	—	—	U	—	P1	D6	UG-496	82-92	1

## BULKHEAD RECEPTACLES

Description	Dimensions, in. (mm)				MTG Hole	Construction Notes			Military Number	Amphenol Number	Fig
	a	b	c	e		CAI	Plt.	Ins.			
Rear Mount/Spade Terminal	1.77 (44.8)	1.25 (31.8)	—	.187 (4.7)	Y	—	P1	D1	—	82-843	2

## ANGLE ADAPTERS

Description	Dimensions, in. (mm)				MTG Hole	Construction Notes			Military Number	Amphenol Number	Fig
	a	b	c	e		CAI	Plt.	Ins.			
Jack-Plug (Copolymer Styrene Ins.)	1.53 (38.9)	.875 (22.2)	1.46 (37.3)	—	—	—	P1	D6	UG-212A	82-91	3

## BULKHEAD ADAPTERS

Description	Dimensions, in. (mm)				MTG Hole	Construction Notes			Military Number	Amphenol Number	Fig
	a	b	c	e		CAI	Plt.	Ins.			
Jack-Jack	1.97 (50.0)	1.00 (25.4)	—	.343 (8.7)	Z	—	P1	D1	UG-1019	11050	4

## DIELECTRIC TRIM TOOL

Description	Dimensions, in. (mm)				MTG Hole	Construction Notes			Military Number	Amphenol Number	Fig
	a	b	c	e		CAI	Plt.	Ins.			
Dielectric Trim Tool	1.47 (37.3)	.625 (15.9)	.500 (12.7)	—	—	—			MX-103/U	103-301	5

## ELECTRICAL

Impedance	50 Ohm constant
Frequency range	0-11 GHz, 1500 V typ.
Voltage Rating	1000 volts peakd
Dielectric Withstanding Voltage	3000 volts RMS
VSWR (MIL-C-39012 Cable Connectors)	1.35 max. 0-11 GHz
Other (MIL-C-39012 Cable Connectors)	Contact Resistance Center contact 1.0 milliohm Outer contact .15 milliohm Braid to Body .05 milliohm RF Leakage: — 90 dB minimum at 3 GHz Insertion loss: .15 dB maximum at 9 GHz Insulation resistance: 5000 megohms. (min.)

NOTE: 13 lb. push required to captivate contact into connector body.

## ENVIRONMENTAL

Temperature range	TFE -65°C to +165°C -65°C to +165°C
Shock	MIL-Std-202 method 213
Vibration	MIL-Std-202 method 204 (test condition B)
Moisture Resistance	MIL-Std-202 method 106
Corrosion	MIL-Std-202 method 101 (test condition B)
Temperature cycling	MIL-Std-202 method 102 (test condition C)

## MECHANICAL

Mating	11/16-24 UNEF screw threads. Plug coupling nut has safety wire holes.
Cable Affixment	Crimp-crimp: hex-crimp jacket, braid, center contact per MIL-C-39012 Category D.
Contact	Captivated
Cable Retention	.155" to .189" dia. cable: 50 lbs. min. .190" to .229" dia. cable: 60 lbs. min. .230" to .249" dia. cable: 75 lbs. min. .250" dia. and larger: 90 lbs. min.

## MATERIAL

Contacts	Male: brass; female; beryllium copper or phosphor bronze, gold plated
Insulators	TFE
Crimp Ferrule	Copper
Other metal parts	Brass

## MILITARY SPECIFICATIONS

MIL-C-39012	where applicable
-------------	------------------

NOTE: These characteristics are typical and may not apply to all connectors.

## PLUG

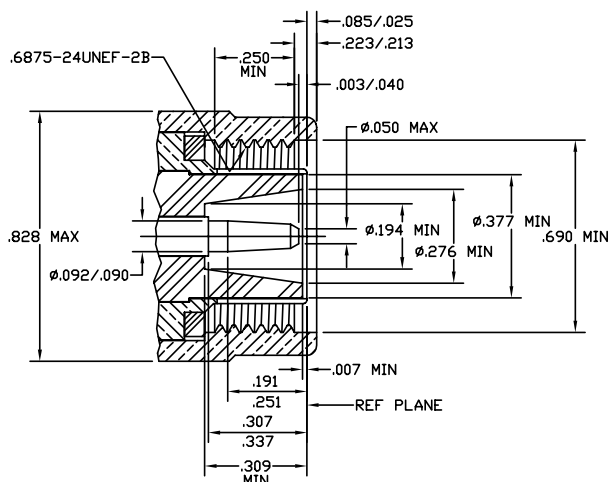

## JACK

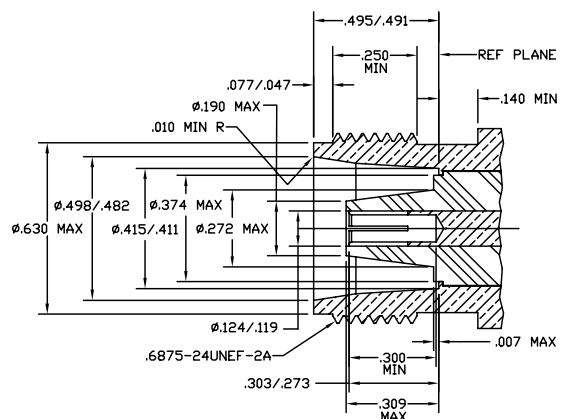

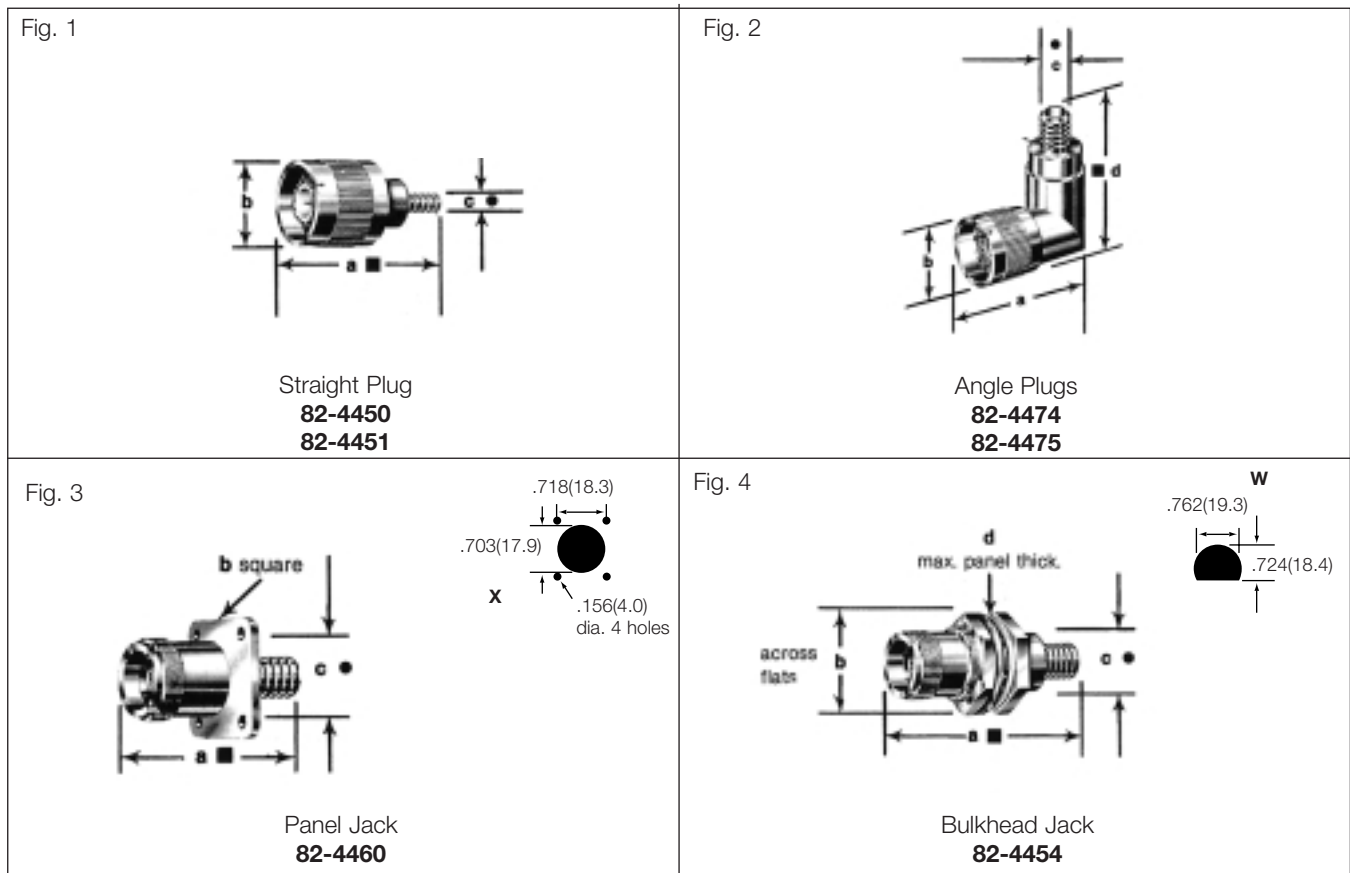

## STRAIGHT PLUGS • Safety Wire Holes

Cable RG-/U	Cable Termination	Dimensions, in. (mm)				MTG Hole	Tool Data Die Set P/N	Construction Notes			Military Number	Amphenol Number	Fig
		a	b	c	d			CAI	Pit.	Ins.			
9, 214, 225, 393	crimp-crimp	1.68 (42.9)	1.83 (21.0)	.444 (11.3)	—	—	227-1221-25	C21	P3	D1	M39012/ 35-0501	82-4450	1
142B, 400	crimp-crimp	1.68 (42.9)	1.83 (21.0)	.195 (5.0)	—	—	227-1221-57	C21	P3	D1	M39012/ 35-0503	82-4451	1

## ANGLE PLUGS • Safety Wire Holes

Cable RG-/U	Cable Termination	Dimensions, in. (mm)				MTG Hole	Tool Data Die Set P/N	Construction Notes			Military Number	Amphenol Number	Fig
		a	b	c	d			CAI	Pit.	Ins.			
9, 214, 225, 393	crimp-crimp	1.50 (38.1)	1.83 (21.0)	.444 (11.3)	2.12 (53.9)	—	227-1221-25	C21	P3	D1	M39012/ 39-0501	82-4474	2
142B, 400	crimp-crimp	1.50 (38.1)	1.83 (21.0)	.195 (5.0)	2.12 (53.9)	—	227-1221-57	C21	P3	D1	M39012/ 39-0503	82-4475	2

## PANEL JACKS • #6-32 Flange Holes - Rear Mount

Cable RG-/U	Cable Termination	Dimensions, in. (mm)				MTG Hole	Tool Data Die Set P/N	Construction Notes			Military Number	Amphenol Number	Fig
		a	b	c	d			CAI	Pit.	Ins.			
9, 214, 225, 393	crimp-crimp	1.56 (39.7)	1.00 (25.4) sq.	.444 (11.3)	—	X	227-1221-25	C21	P3	D1	M39012/ 38-0501	82-4460	3

## BULKHEAD JACKS • Rear Mount

Cable RG-/U	Cable Termination	Dimensions, in. (mm)				MTG Hole	Tool Data Die Set P/N	Construction Notes			Military Number	Amphenol Number	Fig
		a	b	c	d			CAI	Pit.	Ins.			
214, 225, 393	MIL-crimp	1.97 (50.0)	1.00 (25.4) hex.	.438 (11.1)	—	W	227-1221-25	C21	P3	D1	M39012/ 40-0501	82-4454	4

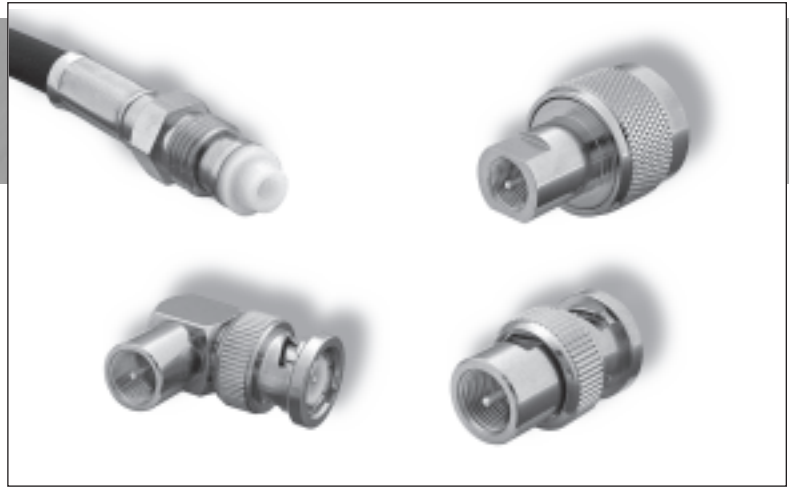

**Description**

Amphenol's 81 Series FME connectors are used for mobile antenna applications and can be adapted for either UHF, Mini-UHF, TNC, BNC and N connector interfaces using BSA adapters.

**Features/Benefits**

- Low cost
- Crimp assembly providing easy installation
- Between Series adapters available for ease of adaptability

**Applications**

- Telecommunications
- Wireless

**Type FME**

Specifications	206
Connectors	207

### ELECTRICAL

Impedance	50 Ohms nominal
Frequency range	DC - 200 MHz

### MATERIAL

Body, coupling sleeve, male contact	Brass
Female contact	Phosphor bronze
Crimp ferrule	Brass
Plating	Contacts: gold Other metal parts: Nickel
Insulator	Teflon or Delrin

### MECHANICAL

Mating	M8XP .75 thd.
Cable affixment	Crimp

### PLUG

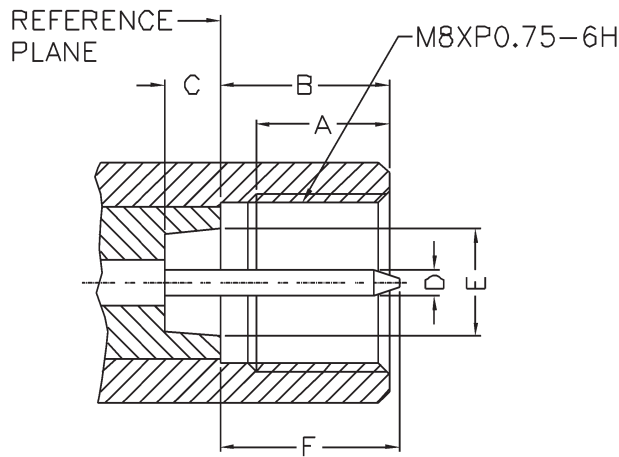

### JACK

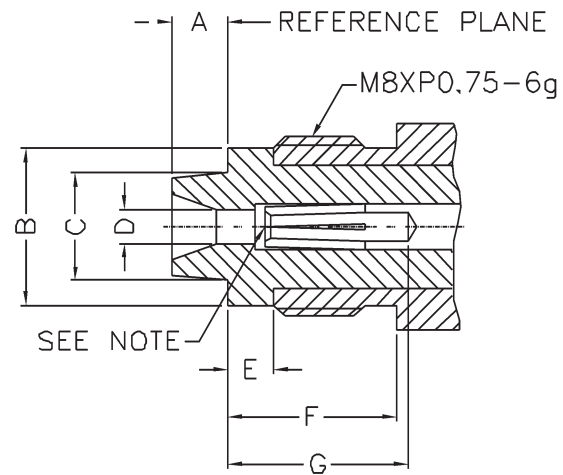

LTR	INCHES		MILLIMETERS	
	MIN	MAX	MIN	MAX
A	.220	—	5.60	—
B	.298	.300	7.58	7.62
C	.098	—	2.50	—
D	.046	.048	1.17	1.23
E	.189	—	4.80	—
F	—	.315	—	8.00

LTR	INCHES		MILLIMETERS	
	MIN	MAX	MIN	MAX
A	—	.098	—	2.50
B	—	.276	—	7.00
C	—	.189	—	4.80
D	.051	—	1.30	—
E	.087	—	2.20	—
F	.315	—	8.00	—
G	.315	—	8.00	—



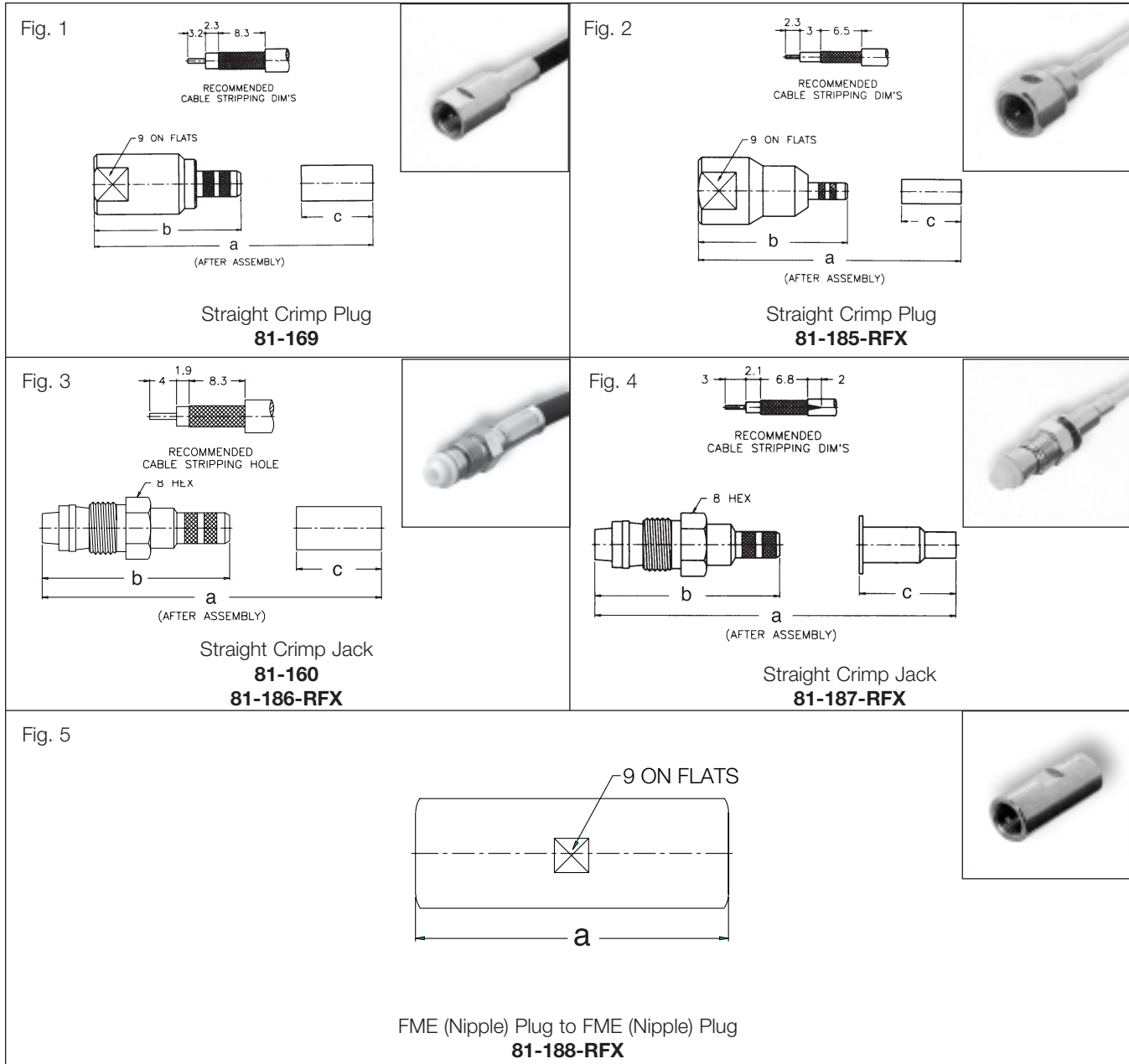

FME

## STRAIGHT CRIMP PLUGS & JACKS, ADAPTER

Cable RG-/U	Description	Cable Termination	Dimensions, in. (mm)			Construction Notes			Other	Amphenol Number	Fig
			a	b	c	CAI	Plt.	Ins.			
58, 141, 142	Plug	Crimp	1.21 (30.8)	1.02 (26.0)	.500 (12.7)	C22	P15	D1	—	81-169	1
174, 188, 316	Plug	Crimp	1.06 (26.9)	.933 (23.7)	.374 (9.5)	C22	P15	D1	—	81-185-RFX	2
58, 141, 142	Jack	Crimp	1.29 (32.8)	1.10 (28.0)	.500 (12.7)	C22	P15	D1	—	81-160	3
58, 141, 142	Jack	Crimp	1.29 (32.8)	1.10 (28.0)	.500 (12.7)	C22	P15	D23	non-captive	81-186-RFX	3
174, 188, 316	Jack	Crimp	1.34 (34.1)	1.04 (26.5)	.500 (12.7)	C22	P15	D23	—	81-187-RFX	4
—	Plug-Plug Adapter	—	1.02 (26.0)	—	—	C22	P1	D23	—	81-188-RFX	5



## Description

Amphenol® Between Series Adapters are used to join two incompatible series. When a single connector series is involved, the adapters are called “In-Series” and are described within the catalog section dealing with that series. The adapters cataloged here provide a transition from one connector series to another.

Amphenol® describes an adapter by referring to its own construction. We indicate the specific series involved and the mating configuration of each end of the adapter required...SMA jack to BNC plug, for instance. One end of the adapter is an SMA jack, the other end is a BNC plug indicating it joins an SMA plug to a BNC jack.

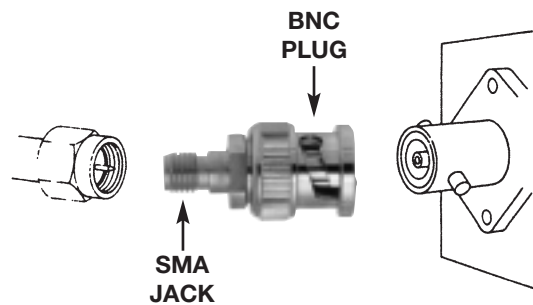
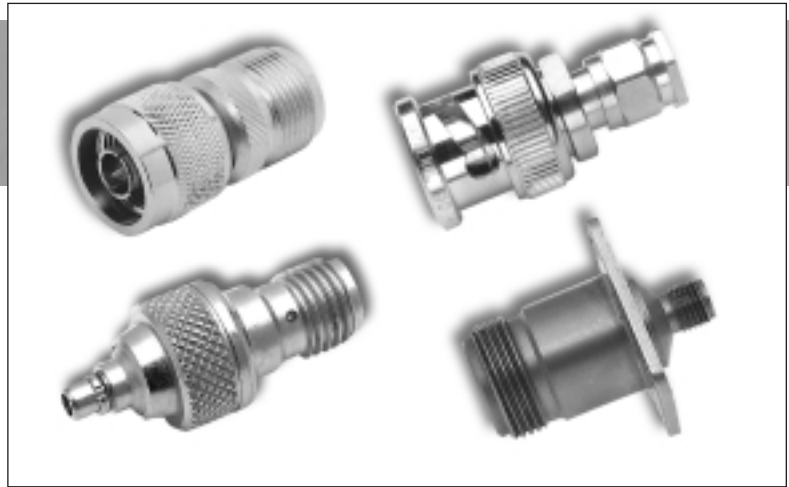

## Features/Benefits

- Broad line of adapters covering all the major series to provide the user maximum flexibility.

## Applications

- Used to join two incompatible series.

## Between Series Adapters

Index	210
Straight Jack-Plug or Jack-Jack	212-215
Straight Plug-Plug or Plug-Jack	216-218
Bulkhead and Panel Mount	219
7/16 - N	220
1.0/2.3	221

## About this Index

You will find the various series listed alphabetically. In addition, this is a redundant index, which means that — because each Between Series Adapter has two distinct ends—we have listed each adapter twice...once under each series. Thus, no matter which end of the adapter comes to mind when you go to look it up in this index, you’ll be able to find it. Also note, the page number refers to the location of the photograph of the adapter.

Adapter Ends	Configuration MIL Number	Amphenol Number	Page	FIG	Adapter Ends	Configuration MIL Number	Amphenol Number	Page	FIG
<b>3.5mm</b>									
3.5mm Jack-N Jack	Panel	901-9718	219	5	SMA Plug-1.0/2.3 Jack	Straight	901-10005	211	1
					SMA Plug-1.0/2.3 Plug	Straight	901-10006	211	2
					SMA Plug-1.0/2.3 Plug	Straight	901-10007	211	3
					SMA Plug-1.0/2.3 Jack	Straight	901-10008	211	4
<b>7/16 Series</b>									
7/16 Jack-N Jack	Straight	APH-716F-NF	220	1	<b>SMB</b>				
7/16 Plug-N Jack	Straight	APH-716M-NF	220	3	SMB Jack-SMA Jack	Straight	901-9033	214	2
7/16 Jack-N Plug	Straight	APH-716F-NM	220	2	SMB Plug-SMA Plug	Straight	901-9034	214	1
7/16 Plug-N Plug	Straight	APH-716M-NM	220	4	SMB Plug-SMA Jack	Straight	901-9038	217	5
<b>APC</b>									
APC-7-SMA Plug	Straight	131-91038	217	7	<b>SMC</b>				
<b>BNC</b>									
BNC Jack-N Plug	Straight UG-201A/U	31-216	212	1	SMB Jack-BNC Jack	Blkh. .062 amp fuse	903-377A-52B1	219	2
BNC Jack-N Plug	Straight	31-216-RFX	212	1	<b>TNC</b>				
BNC Jack-N Plug	Straight M55339/20-00201	82-5558	212	1	TNC Jack-BNC Plug	Straight	79025	216	5
BNC Jack-N Jack	Straight M55339/01-00001	82-5550	215	4	TNC Jack-N Jack	Straight	78825	213	4
BNC Jack-N Jack	Straight M55339/25-00606	82-5561	219	7	TNC Jack-N Plug	Straight	78800	217	3
BNC Jack-SMA Jack	Straight	901-167	212	3	TNC Jack-SMA Jack	Straight	901-171	214	3
BNC Jack-SMA Jack	Bulkhead	901-9173	219	4	TNC Jack-SMA Jack	Panel	901-280	219	6
BNC Jack-SMA Plug	Straight	901-166	212	2	TNC Plug-BNC Jack	Straight	79675	212	4
BNC Jack-SMC Jack	Blkh. .062 amp fuse	903-377A-52B1	219	2	TNC Plug-N Jack	Straight	79825	213	5
BNC Jack-SMA Plug	Straight	79675	212	4	TNC Plug-SMA Plug	Straight	901-168	217	6
BNC Jack-UHF Plug	Straight UG-273/U	31-28	212	5	TNC Plug-FME Plug	Straight	81-162	218	3
BNC Jack-UHF Plug	Straight	31-28-RFX	212	5	TNC Plug-FME Plug	Right Angle	81-191-RFX	218	8
BNC Plug-N Jack	Straight UG-349A/U	31-217	210	2	<b>Type F</b>				
BNC Plug-N Jack	Straight	31-217-RFX	216	2	F Jack-G Plug	Straight	531-40010	215	1
BNC Plug-N Plug	Straight UG-10343/U	5225	216	1	F Jack-G Jack	Straight	531-40009	215	2
BNC Plug-SMA Jack	Straight	901-165	216	4	<b>Type G</b>				
BNC Plug-SMA Jack	Straight	901-164	216	3	G Plug-F Jack	Straight	531-40010	215	1
BNC Plug-UHF Jack	Straight	79025	216	6	G Jack-F Jack	Straight	531-40009	215	2
BNC Plug-TNC Jack	Straight UG-255/U	2900	216	5	<b>Type N</b>				
BNC Plug-FME Plug	Straight	81-189-RFX	218	6	N Jack-BNC Plug	Straight UG-349A/U	31-217	216	2
BNC Plug-FME Plug	Right Angle	81-190-RFX	218	7	N Jack-BNC Plug	Straight	31-217-RFX	216	2
<b>FME</b>					N Jack-BNC Jack	Straight M55339/01-00001	82-5550	215	4
FME Plug-Mini-UHF Plug	Straight	81-161	218	2	N Jack-BNC Jack	Straight M55339/25-00606	82-5561	219	7
FME Plug-TNC Plug	Straight	81-162	218	3	N Jack-HN Plug	Straight	16050	213	3
FME Plug-BNC Plug	Straight	81-189-RFX	218	6	N Jack-SMA Jack	Straight	901-295	213	2
FME Plug-BNC Plug	Right Angle	81-190-RFX	218	7	N Jack-SMA Jack	Bulkhead	901-3143-1000	219	1
FME Plug-UHF Plug	Straight	81-193-RFX	218	1	N Jack-SMA Jack	Panel	901-9720	219	3
FME Plug-UHF Plug	Straight	81-192-RFX	218	9	N Jack-SMA Plug	Straight	901-293	213	1
FME Plug-N Plug	Straight	81-191-RFX	218	8	N Jack-TNC Jack	Straight	78825	213	4
FME Plug-TNC Plug	Right Angle	81-191-RFX	218	8	N Jack-TNC Plug	Straight	79825	213	5
<b>HN Series</b>					N Jack-UHF Plug	Straight UG-83/U	14000	213	6
HN Jack-N Plug	Straight	16075	212	6	N Jack-3.5mm Jack	Jack Panel	901-9718	218	5
HN Plug-N Jack	Straight	16050	213	3	N Jack-7/16 Jack	Straight	APH-716F-NF	220	1
<b>Mini-UHF</b>					N Jack-7/16 Plug	Straight	APH-716M-NF	220	3
Mini-UHF Plug-UHF Plug	Straight	83-910-RFX	218	4	N Plug-BNC Jack	Straight UG-201A/U	31-216	212	1
Mini-UHF Plug-FME Plug	Straight	83-161	218	2	N Plug-BNC Jack	Straight M55339/20-00201	82-5558	212	1
<b>MMCX</b>					N Plug-BNC Plug	Straight UG-1034/U	5225	215	1
MMCX Plug-SMA Jack	Straight	908-31100	218	5	N Plug-HN Jack	Straight	16075	212	6
MMCX Jack-SMA Plug	Straight	908-32101	215	3	N Plug-SMA Jack	Straight	901-294	217	2
<b>RCA</b>					N Plug-SMA Plug	Straight	901-292	217	1
RCA Plug-UHF Jack	Straight	83-10	214	4	N Plug-TNC Jack	Straight	78800	217	3
<b>SMA</b>					N Plug-UHF Jack	Straight UG-146/U	4400	217	4
SMA Jack-BNC Jack	Straight	901-167	212	3	N Plug-7/16 Jack	Straight	APH-716F-NM	220	2
SMA Jack-BNC Jack	Bulkhead	901-9173	219	4	N Plug-7/16 Plug	Straight	APH-716M-NM	220	4
SMA Jack-BNC Plug	Straight	901-165	216	4	N Plug-FME Plug	Straight	81-192-RFX	218	9
SMA Jack-N Jack	Straight	901-295	213	2	<b>UHF</b>				
SMA Jack-N Jack	Bulkhead	901-3143-1000	218	1	UHF Jack-BNC Plug	Straight UG-255/U	2900	216	6
SMA Jack-N Jack	Panel	901-9720	219	3	UHF Jack-N Plug	Straight UG-146/U	4400	217	4
SMA Jack-N Plug	Straight	901-294	217	2	UHF Jack-RCA Plug	Straight	83-10	214	4
SMA Jack-SMB Jack	Straight	901-9033	214	2	UHF Plug-BNC Jack	Straight UG-277/U	31-28	212	5
SMA Jack-SMB Plug	Straight	901-9034	214	1	UHF Plug-BNC Jack	Straight	31-28-RFX	212	5
SMA Jack-TNC Jack	Straight	901-171	214	3	UHF Plug-N Jack	Straight UG-83/U	14000	213	6
SMA Jack-TNC Jack	Panel	901-280	215	6	UHF Plug-Mini-UHF Plug	Straight	83-910-RFX	218	4
SMA Plug-BNC Jack	Straight	901-166	212	2	UHF Plug-FME Plug	Straight	81-193-RFX	218	1
SMA Plug-BNC Plug	Straight	901-164	216	3	<b>1.0/2.3 Jack SMA Plug</b>				
SMA Plug-N Jack	Straight	901-293	213	1	1.0/2.3 Jack SMA Plug	Straight	901-10005	211	1
SMA Plug-N Plug	Straight	901-292	219	1	1.0/2.3 Plus SMA Plug	Straight	901-10006	211	2
SMA Jack-MMCX Plug	Straight	908-31100	218	5	1.0/2.3 Plug SMA Plug	Straight	901-10007	211	3
SMA Jack-MMCX Jack	Straight	908-32101	215	3	1.0/2.3 Jack SMA Plug	Straight	901-10008	211	4
SMA Plug-SMB Plug	Straight	901-9038	217	5					
SMA Plug-TNC Plug	Straight	901-168	217	6					
SMA Plug-APC-7	Straight	131-91038	217						

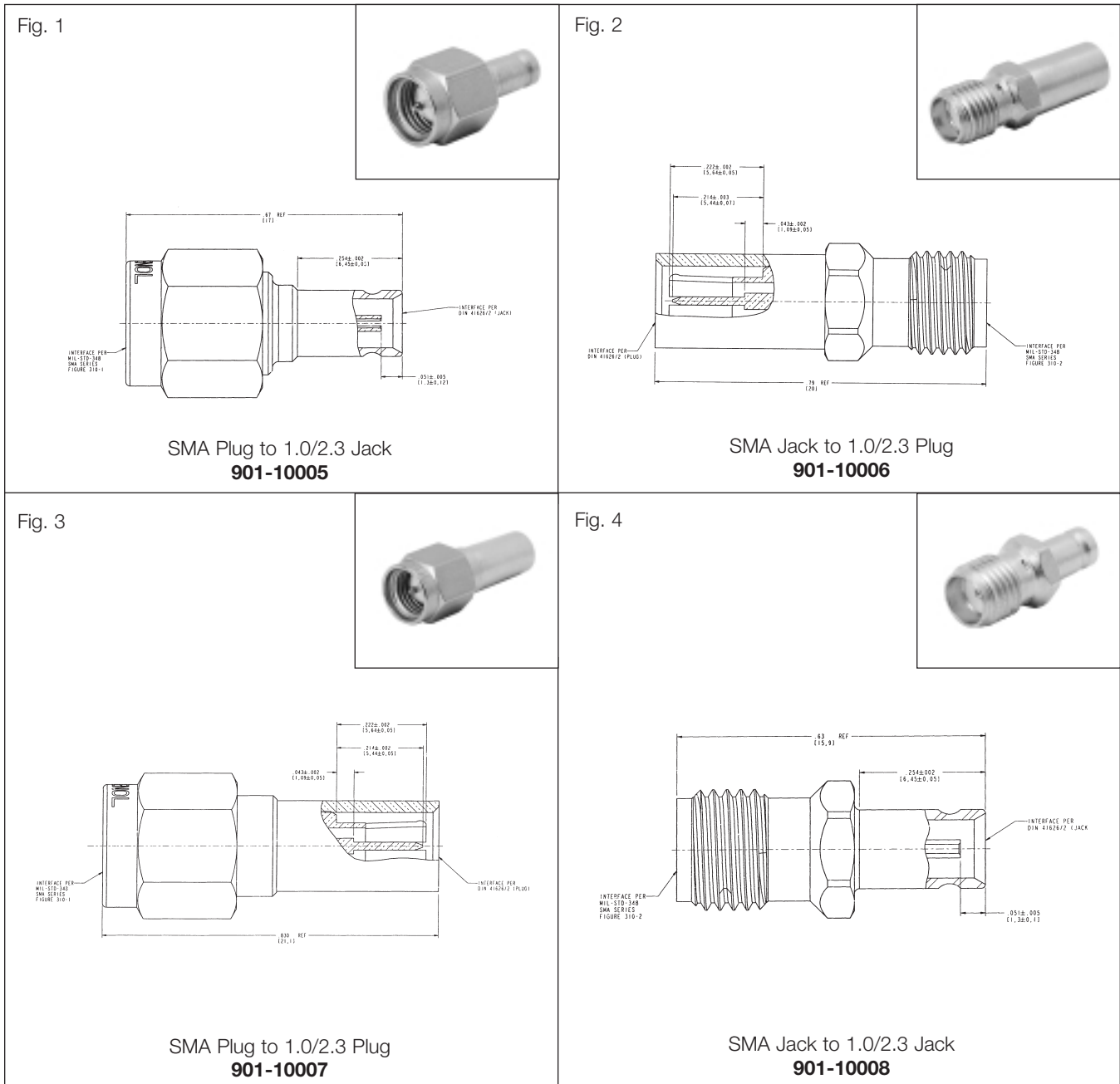

Adapters

### 1.0/2.3 ADAPTER

Description	Ins.	Construction notes	Amphenol Number	Fig
SMA Plug to 1.0/2.3 Jack	D1	Gold Plated	<a href="#">901-10005</a>	1
SMA Jack to 1.0/2.3 Plug	D1	Gold Plated	<a href="#">901-10006</a>	2
SMA Plug to 1.0/2.3 Plug	D1	Gold Plated	<a href="#">901-10007</a>	3
SMA Jacks to 1.0/2.3 Jack	D1	Gold Plated	<a href="#">901-10008</a>	4

# Adapters, Between Series Straight, Jack to Plug or Jack to Jack

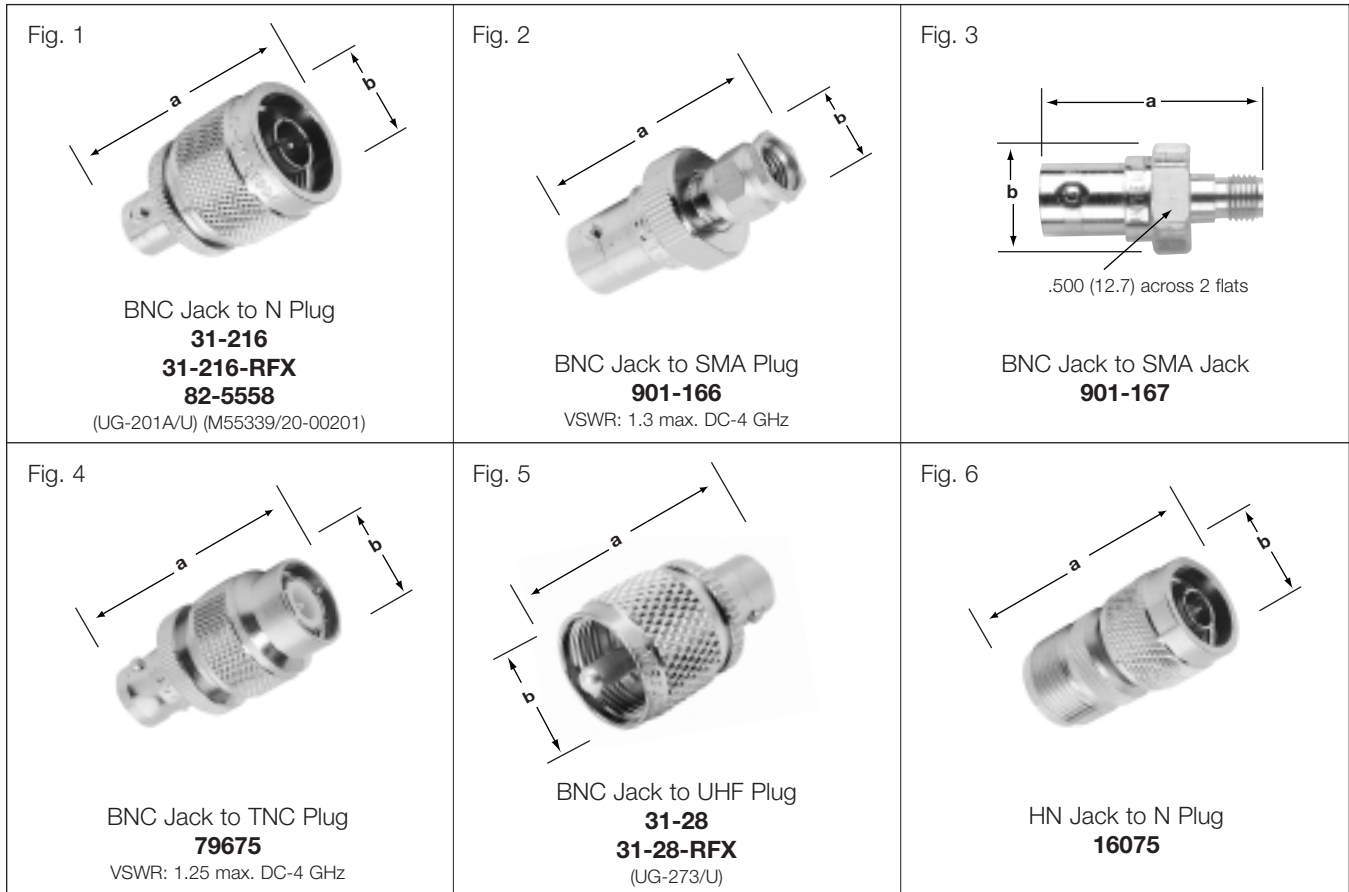

## STRAIGHT ADAPTERS - JACK TO PLUG OR JACK TO JACK

Adapter Ends		Dimension, inch (millimeters)		Notes		Military Number	Amphenol Number	Fig.
		a	b	Plt.	Ins.			
BNC Jack	N Plug	1.31 (33.3)	.812 (20.6)	P1	D1	UG-201A/U	<a href="#">31-216</a>	1
BNC Jack	N Plug	1.31 (33.3)	.812 (20.6)	P1	D1	UG-201A	<a href="#">31-216-RFX</a>	1
BNC Jack	N Plug	1.36 (34.4)	.828 (21.0)	P6	D1	M55339/20-00	<a href="#">82-5558</a>	1
BNC Jack	SMA Plug	1.16 (29.4)	.562 (14.3)	P51	D1	-	<a href="#">901-166</a>	2
BNC Jack	SMA Jack	1.12 (28.6)	.562 (14.3) dia.	P51	D1	-	<a href="#">901-167</a>	3
BNC Jack	TNC Plug	1.25 (31.8)	.525 (15.9)	P1	D1	-	<a href="#">79675</a>	4
BNC Jack	UHF Plug	1.19 (30.2)	.719 (18.3)	P1	D6	UG-273/U	<a href="#">31-28</a>	5
BNC Jack	UHF Plug	1.19 (30.2)	.719 (18.3)	P1	D6	UG-273/U	<a href="#">31-28-RFX</a>	5
HN Jack	N Plug	1.56 (39.7)	.813 (20.6)	P1	D1	-	<a href="#">16075</a>	6

# Adapters, Between Series Straight, Jack to Plug or Jack to Jack

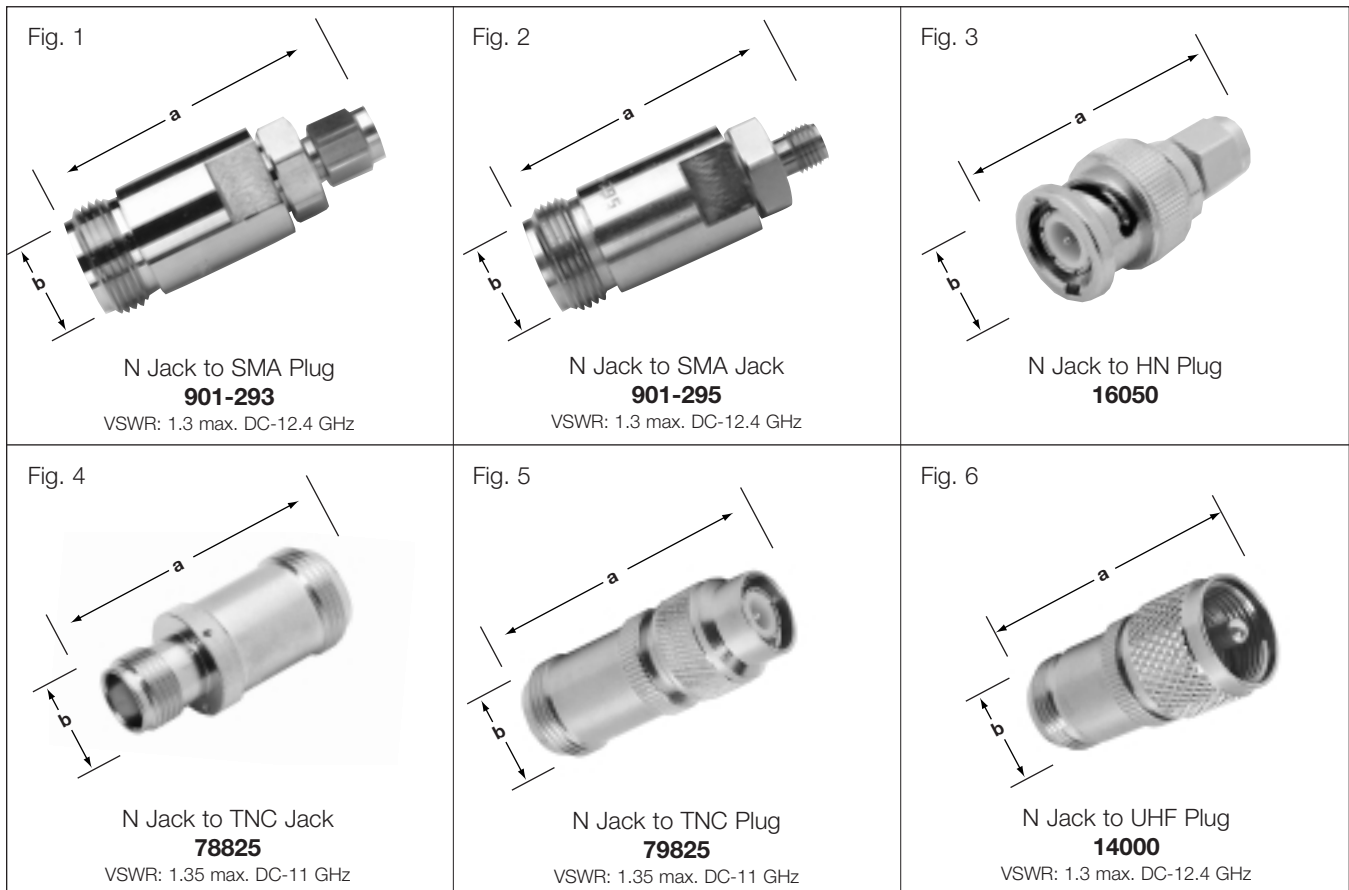

Adapters

## STRAIGHT ADAPTERS - JACK TO PLUG OR JACK TO JACK

Adapter Ends		Dimension, inch (millimeters)		Notes		Military Number	Amphenol Number	Fig.
		a	b	Pit.	Ins.			
N Jack	SMA Plug	1.70 (43.2)	.625 (15.9) dia.	P52	D1	-	<b>901-293</b>	1
N Jack	SMA Jack	1.66 (42.1)	.625 (15.9) dia.	P9	D1	-	<b>901-295</b>	2
N Jack	HN Plug	1.5 (39.7)	.875 (22.2)	P1	D1	-	<b>16050</b>	3
N Jack	TNC Jack	1.39 (35.3)	.625 (15.9)	P1	D1	-	<b>78825</b>	4
N Jack	TNC Plug	1.66 (42.1)	.625 (15.9)	P1	D1	-	<b>79825</b>	5
N Jack	UHF Plug	1.56 (39.7)	.750 (19.1)	P1	D1/6	UG-83/U	<b>14000</b>	6

# Adapters, Between Series Straight, Jack to Plug or Jack to Jack

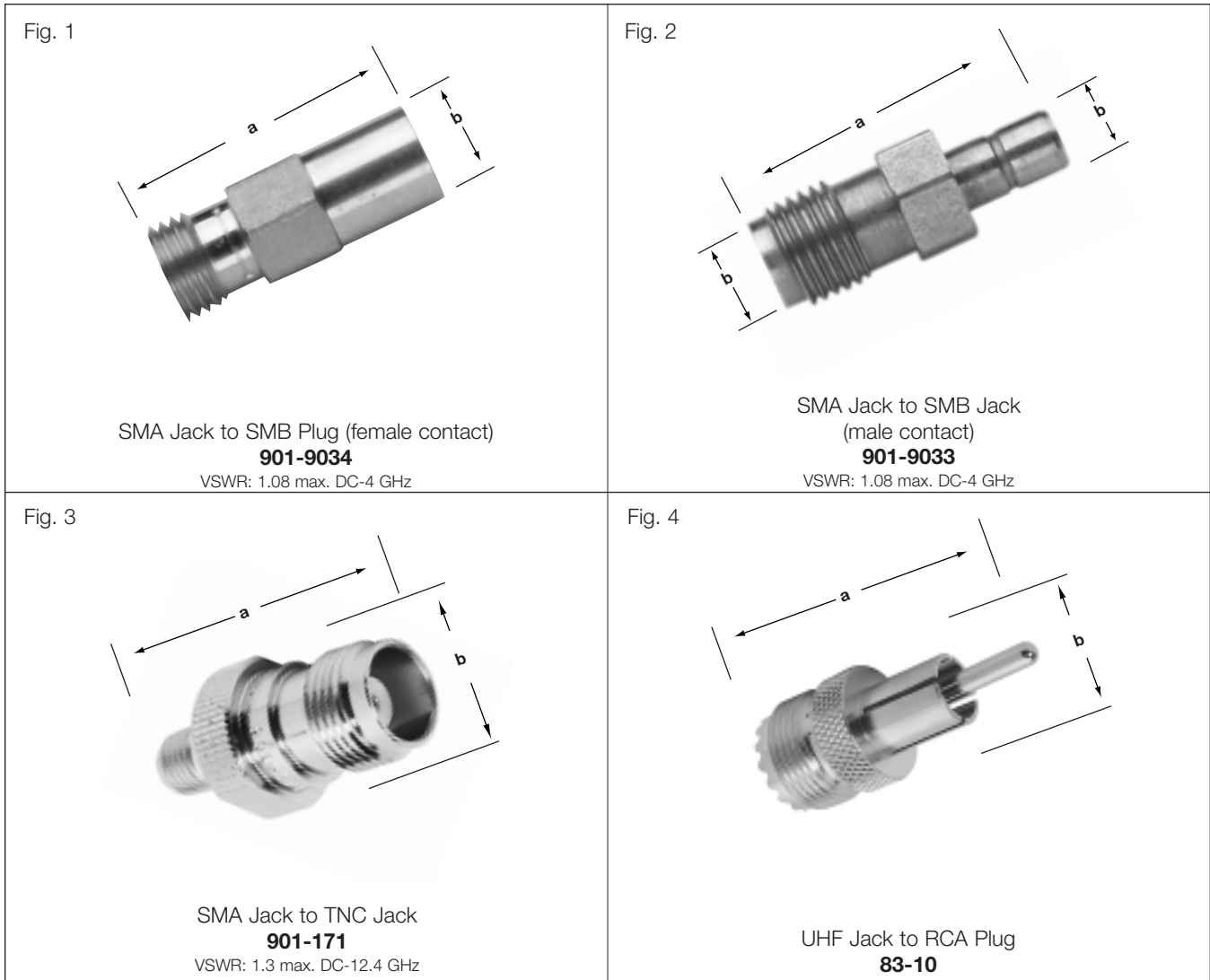

## STRAIGHT ADAPTERS - JACK TO PLUG OR JACK TO JACK

Adapter Ends		Dimension, inch (millimeters)		Notes		Military Number	Amphenol Number	Fig.
		a	b	Plt.	Ins.			
SMA Jack	SMB Plug	.750 (19.1)	.250 (6.4) hex.	P1	D1	-	<b>901-9034</b>	1
SMA Jack	SMB Jack	705 (17.9)	.250 (6.4) hex.	P12	D1	-	<b>901-9033</b>	2
SMA Jack	TNC Jack	1.12 (28.6)	.562 (14.3) dia.	P51	D1	-	<b>901-171</b>	3
UHF Jack	RCA Plug	1.64 (41.7)	.650 (16.5) dia.	P2	D33	-	<b>83-10</b>	4



# Adapters, Between Series Straight, Jack to Plug or Jack to Jack

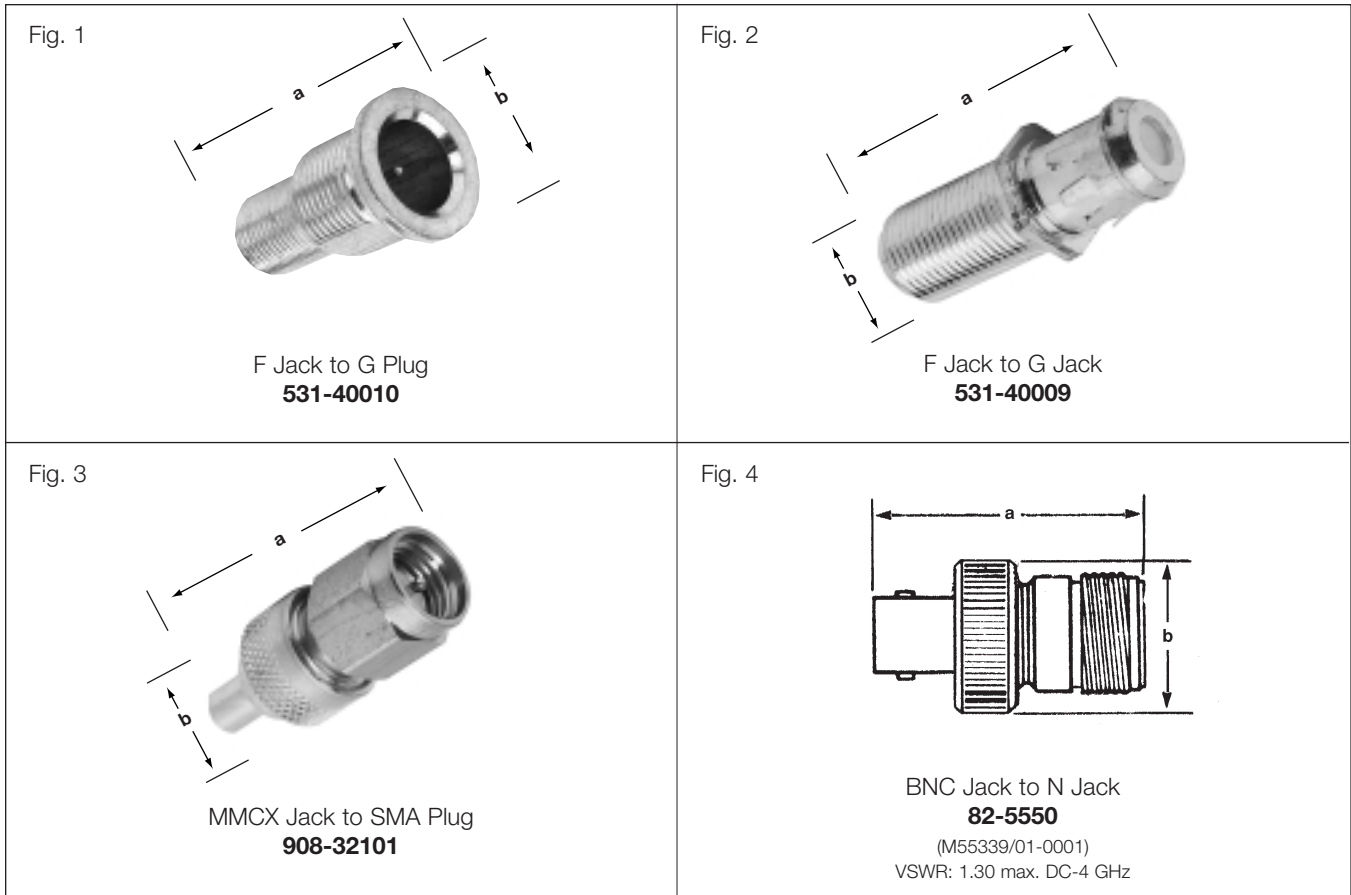

Adapters

### STRAIGHT ADAPTERS - JACK TO PLUG OR JACK TO JACK

Adapter Ends		Dimension, inch (millimeters)		Notes		Military Number	Amphenol Number	Fig.
		a	b	Pit.	Ins.			
F Jack	G Plug	.93 (23.6)	.625 (15.88)	P36	D1	-	<a href="#">531-40010</a>	1
F Jack	G Jack	1.15 (29.2)	.375 (9.53)	P37	D1	-	<a href="#">531-40009</a>	2
MMCX Jack	SMA Plug	.878 (22.3)	.354 (9.00)	P29	D1	-	<a href="#">908-32101</a>	3
BNC Jack	N Jack	1.14 (28.96)	.750 (19.05)	P33	D1	M55339/01-0001	<a href="#">82-5550</a>	4

# Adapters, Between Series Straight, Plug to Plug or Plug to Jack

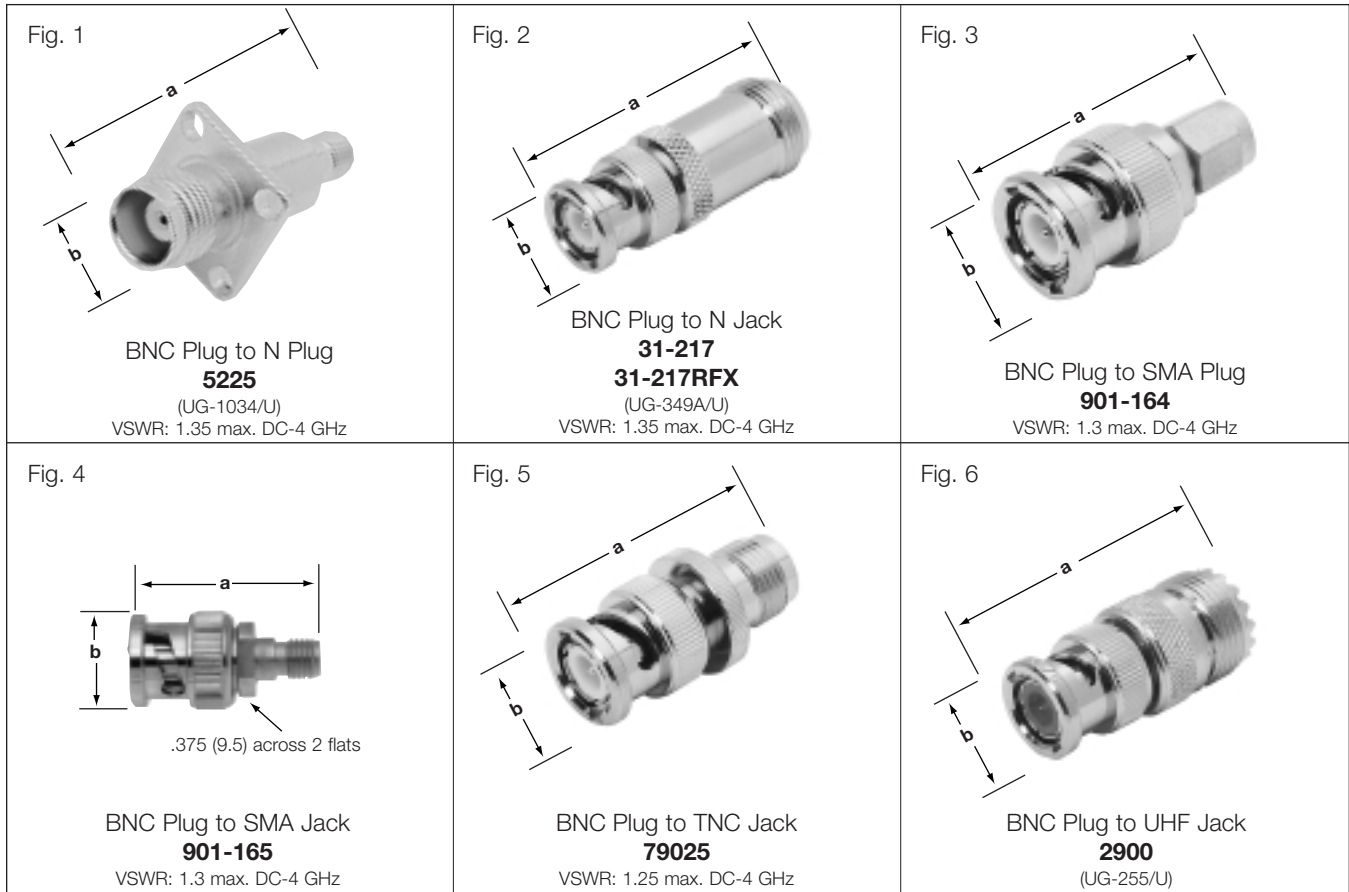

## STRAIGHT ADAPTERS - PLUG TO PLUG OR PLUG TO JACK

Adapter Ends		Dimension, inch (millimeters)		Notes		Military Number	Amphenol Number	Fig.
		a	b	Plt.	Ins.			
BNC Plug	N Plug	1.50 (38.1)	.812 (20.6)	P4	D1	UG-1034/U	<b>5225</b>	1
BNC Plug	N Jack	1.56 (39.7)	.625 (15.9)	P1	D1	UG-349A/U	<b>31-217</b>	2
BNC Plug	N Jack	1.56 (39.7)	.625 (15.9)	P1	D1	-	<b>31-217-RFX</b>	2
BNC Plug	SMA Plug	1.09 (27.8)	.562 (14.3) dia.	P49	D1	-	<b>901-164</b>	3
BNC Plug	SMA Jack	1.06 (27.0)	.562 (14.3)	P8	D1	-	<b>901-165</b>	4
BNC Plug	TNC Jack	1.25 (31.8)	.625 (15.9)	P1	D1	-	<b>79025</b>	5
BNC Plug	UHF Jack	1.31 (33.3)	.625 (15.9)	P1	D6/8	UG-255/U	<b>2900</b>	6

# Adapters, Between Series Straight, Plug to Plug or Plug to Jack

Fig. 1

N Plug to SMA Plug  
**901-292**  
VSWR: 1.3 max. DC-12.4 GHz

Fig. 2

N Plug to SMA Jack  
**901-294**  
VSWR: 1.3 max. DC-12.4 GHz

Fig. 3

N Plug to TNC Jack  
**78800**  
VSWR: 1.35 max. DC-11 GHz

Fig. 4

N Plug to UHF Jack  
**4400**  
(UG-146/U)

Fig. 5

SMA Plug to SMB Plug  
(Female Contact)  
**901-9038**  
VSWR: 1.08 max. DC-4 GHz

Fig. 6

SMA Plug to TNC Plug  
**901-168**  
VSWR: 1.3 max. DC-4 GHz

Fig. 7

SMA Plug to APC-7  
**131-91038**

Adapters

### STRAIGHT ADAPTERS - PLUG TO PLUG OR PLUG TO JACK

Adapter Ends		Dimension, inch (millimeters)		Notes		Military Number	Amphenol Number	Fig.
		a	b	Plt.	Ins.			
N Plug	SMA Plug	1.70 (43.2)	.812 (20.6) dia.	P52	D1	-	<a href="#">901-292</a>	1
N Plug	SMA Jack	1.66 (42.1)	.812 (20.6)	P9	D1	-	<a href="#">901-294</a>	2
N Plug	TNC Jack	1.94 (33.3)	.813 (20.6)	P1	D1	-	<a href="#">78800</a>	3
N Plug	UHF Jack	1.41 (35.7)	.813 (20.6)	P1	D6/8	UG-146/U	<a href="#">4400</a>	4
SMA Plug	SMB Plug	.875 (22.2)	.312 (7.9) hex.	P29	D1	-	<a href="#">901-9038</a>	5
SMA Plug	TNC Plug	1.12 (28.6)	.593 (15.1) dia.	P51	D1	-	<a href="#">901-168</a>	6
SMA Plug	APC-7	1.39 (35.3)	.865 (22.0)	P29	D1	-	<a href="#">131-91038</a>	7

# Adapters, Between Series Plug to Plug or Plug to Jack

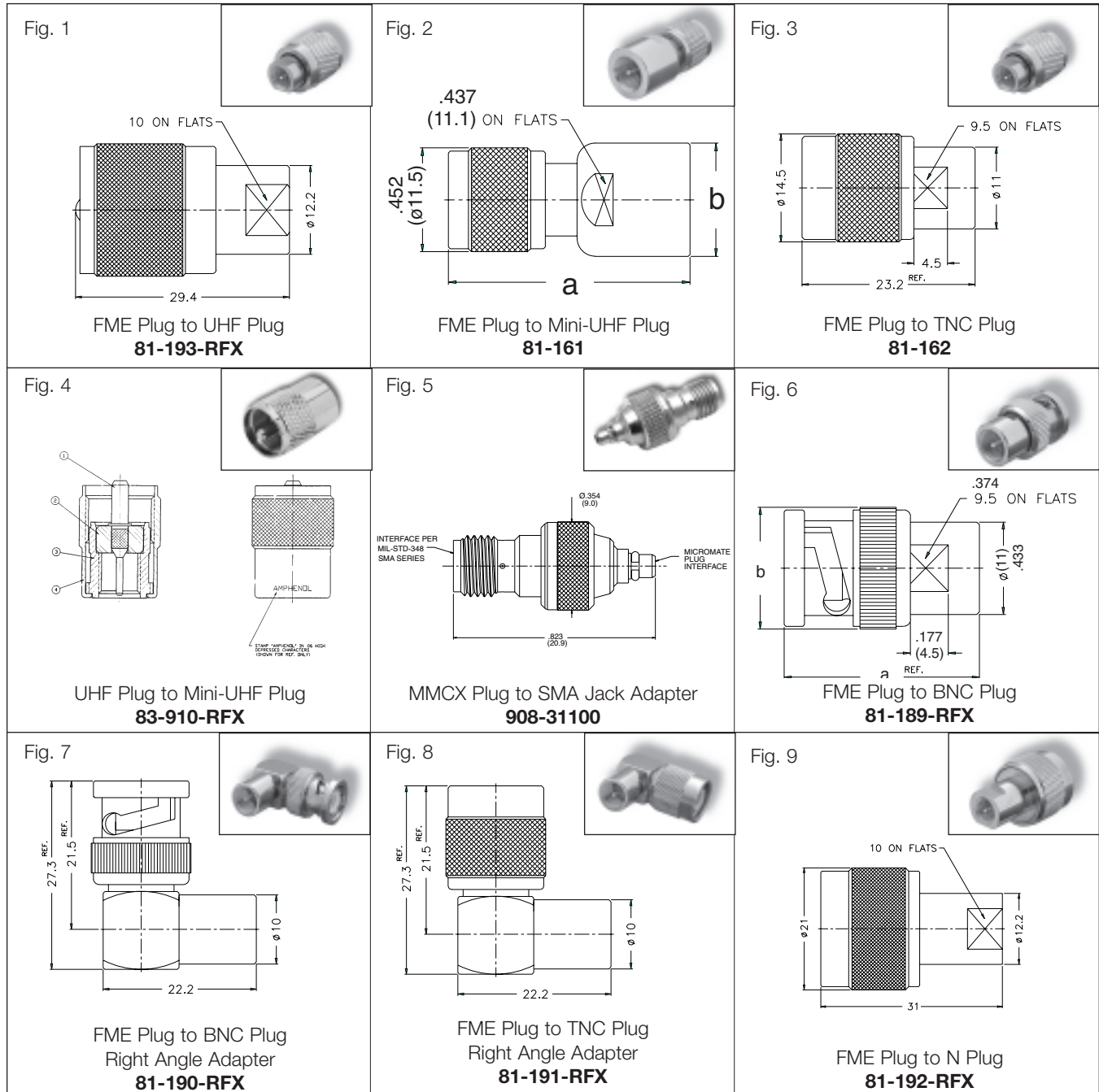

## ADAPTERS — PLUG TO PLUG OR PLUG TO JACK

Adapter Ends		Dimension, inch (millimeters)		Notes		Description	Amphenol Number	Fig.
		a	b	Pit.	Ins.			
FME Plug	UHF Plug	1.16 (29.4)	.480 (12.2)	P1	D1	Straight	<a href="#">81-193-RFX</a>	1
FME Plug	Mini-UHF Plug	.492 (12.5)	1.04 (26.5)	P1	D23	Straight	<a href="#">81-161</a>	2
FME Plug	TNC Plug	.913 (23.2)	.571 (14.5)	P1	D23	Straight	<a href="#">81-162</a>	3
UHF Plug	Mini-UHF Plug	1.04 (26.4)	.750 (19.1)	P5	D23	Straight	<a href="#">83-910-RFX</a>	4
MMCX Plug	SMA Jack	.823 (20.9)	.354 (9.0)	P11	D1	Straight	<a href="#">908-31100</a>	5
BNC Plug	FME Plug	.913 (23.2)	.571 (9.0)	P1	D23	Straight	<a href="#">81-189-RFX</a>	6
BNC Plug	FME Plug	1.07 (27.3)	.874 (22.2)	P1	D23	Right Angle	<a href="#">81-190-RFX</a>	7
FME Plug	TNC Plug	1.07 (27.3)	.874 (22.2)	P1	D23	Right Angle	<a href="#">81-191-RFX</a>	8
FME Plug	N Plug	1.22 (31.0)	.480 (12.2)	P1	D1	Straight	<a href="#">81-192-RFX</a>	9

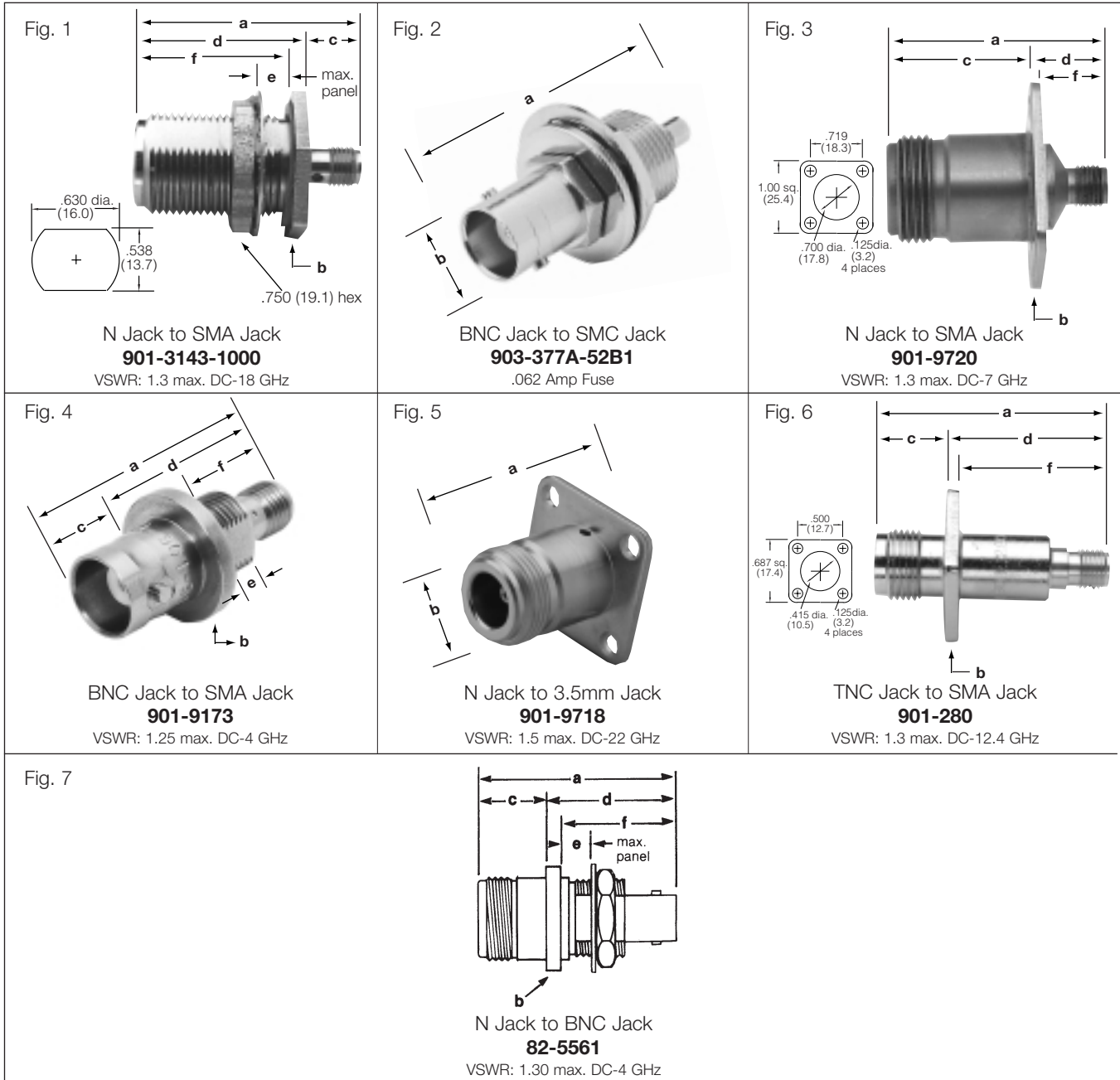

## BULKHEAD AND PANEL MOUNT ADAPTERS

Adapter Ends	Dimensions, Inches (millimeters)						Plt.	Ins.	Mtg. Hole	Notes	Amphenol Number	Fig.
	A	b	c	d	e	f						
N Jack- SMA Jack	1.36 (34.6)	.812 (20.6) hex. .094 (2.4) thick	.348 (8.8)	1.01 (25.7)	.685 (17.4)	.918 (23.3)	P31	D1	U	Bulkh. Mount w/ gasket	<b>901-3143-1000</b>	1
BNC Jack SMC Jack	1.32 (33.6)	.710 (18.0) dia. .060 (1.5) thick	.529 (13.4)	.796 (20.2)	.250 (6.4)	.736 (18.7)	P32	D1	W	.062 amp Fuse	<b>903-377A-52B1</b>	2
N Jack SMA Jack	1.23 (31.2)	1.00 (25.4) sq. .080 (2.0) thick	.787 (20.0)	.445 (11.3)	-	.365 (9.3)	P31	D1	N	4-hole Flange Mount	<b>901-9720</b>	3
BNC Jack SMA Jack	1.12 (28.6)	.595 (15.1) dia. .090 (2.3) thick	.425 (10.8)	.700 (17.8)	.125 (3.2) max.	.610 (15.5)	P30	D1	D	Bulkh. Mount w/ gasket	<b>901-9173</b>	4
N Jack 3.5 mm Jack	1.23 (31.2)	1.00 (25.4) sq. .080 (2.0) thick	.787 (20.0)	.445 (11.3)	-	.365 (9.3)	P31	D1	N	4-hole Flange Mount	<b>901-9718</b>	5
TNC Jack SMA Jack	1.42 (36.1)	.687 (17.4) sq. .090 (2.3) thick	.425 (10.8)	1.00 (25.4)	-	.910 (23.1)	P51	D1	T	4-hole Flange Mount	<b>901-280</b>	6
BNC Jack N Jack	1.78 (45.2)	.900 (22.9)	.587 (14.9)	1.19 (30.2)	.300 (7.6)	1.04 (26.4)	P34	D1	U	Bulkh. Mount Pressurized	<b>82-5561</b>	7

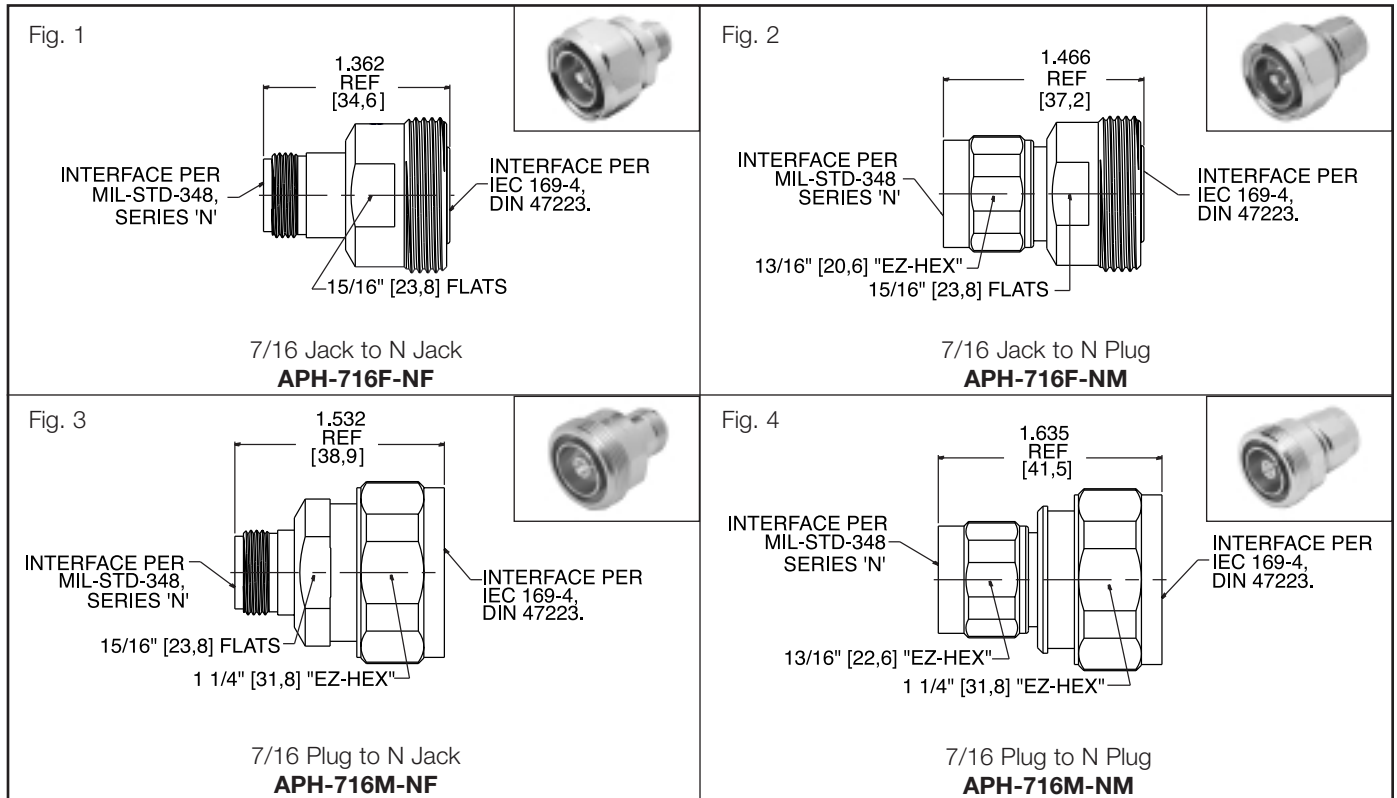

### 7/16 TO N BETWEEN SERIES ADAPTERS

Amphenol Part Number	Description	Fig
<a href="#">APH-716F-NF</a>	716 Female to Type N Female Adapter	1
<a href="#">APH-716F-NM</a>	716 Female to Type N Male Adapter	2
<a href="#">APH-716M-NF</a>	716 Male to Type N Female Adapter	3
<a href="#">APH-716M-NM</a>	716 Male to Type N Male Adapter	4

Note: In our adapter terminology, we describe an adapter by referring to its own construction, not by what the adapter connects to.

# Notes

Lined area for notes, consisting of multiple horizontal dotted lines.





# Contents

Type N .....	.224
Type F .....	.245
Type G .....	.253
7/16 .....	.259

# Wireless



Amphenol's family of "Wireless" connectors includes N, F, G, and 7/16 type connectors. The primary usage of Wireless types are for the communications/broadband industries. This line features superior performance to today's highest industry standards. Our Wireless connectors feature threaded coupling mechanisms, a variety of cable choices, and PCB solutions.

Amphenol **Type N** connectors are a 50 ohm coaxial interconnect series featuring threaded coupling mechanism and excellent RF performance for DC to 11 GHz. These connectors are available for a wide range of popular cable sizes and crimp/crimp terminations for low cost installation.

**Type F** connectors serve both the low cost and high performance market. With prices ranging from \$.50 to \$.95, Amphenol provides a high performance solution. All connectors comply with a 3/8-32 thread specification.

The Type F is similar to the Type G except it is threaded rather than snap-on. Primary applications are for cable television (CATV), set top boxes, and cable modems

Amphenol's Type F achieves a -30dB return loss at 1 GHz and accepts any cable center conductor from .022 to .042.

The **Type G** is a snap-on alternative to the Type F with a 15A continuous current rating.

All connectors comply with the 3/8-32 UNEF Thread specification and the Mil-Std 202 specification for vibration, shock, thermal shock, moisture resistance and salt spray.

Since the Type G has an impedance of 75 ohms, it is ideal for CATV applications.

The Type G line consists of Bulkhead Mount Jack Receptacles and PCB Mount Jack Receptacles.

The **7/16** series name derives from the metric dimensions of the connector interface: 7mm OD of inner contact, 16mm ID of outer contact. 7/16 connectors are designed for use in communications systems with power levels of 100 watts per channel.

Long popular in Europe, the 7/16 interface has gained acceptance in the U.S. for its ability to operate at elevated power levels.

There are three families of 7/16 DIN connectors:

- Corrugated Cable Connectors (for both Annular and Superflex cable)
- Standard Cable Connectors
- Custom (Series 7/16)

Deutsh Industries Norm (DIN) are German standards gaining acceptance worldwide.

## Description

Named for Paul Neill of Bell Labs and developed in the 1940's. The Type N offered the first true microwave performance.

Type N connector was developed to satisfy the need for a durable, weatherproof medium size RF connector with consistent performance through 11 GHz.

There are two families of Type N connectors:

- Standard N (Coaxial Cable)
- Helical N (Corrugated Cable)

Primary applications are the termination of medium to miniature size coaxial cable:

RG-8 and RG-225

RG-58 and RG-141

## Features/Benefits

- Accommodates a wide range of medium to miniature sized RG coaxial cables in a rugged medium size design. Provides customer flexibility in their design and manufacturing with a durable connector.
- Broad line of Military (M39012 prefix), Industrial (UG prefix), and Commercial Grade (RFX suffix) products available. Gives customer choices in weighing cost versus performance benefits.
- Available in many styles: Plugs (Straight and Right Angle) and Jacks (Panel Mount, Bulkhead Mount, Receptacle). Meets many customer application demands.

## Application

- Antennas
- Base Stations
- Broadcast
- Cable Assemblies
- Components
- Instrumentation
- Mil-Aero
- Radar
- Radios
- Satcom
- Surge Protection
- WLAN



## Type N

Specifications	226
Cable Plugs	227
Right Angle Plugs	228
Jacks	229-232
Receptacles, Accessories	234-235
Adapters	236

## Helical N Corrugated Cable Connectors

Specifications	239
Plugs	240-241
Jacks	242-243

## ELECTRICAL

Impedance	50 ohms
Frequency range	0-11 GHz
Voltage rating	1,500 volts peak
Dielectric withstanding voltage	2,500 volts rms.
VSWR (MIL-C-39012 cable connectors)	M39012 straight connectors: 1.3 max. 0-11 GHz M39012 right angle: 1.35 max. 0-11 GHz
Other	Contact resistance: center contact 1.0 milliohm outer contact 0.2 milliohm  RF leakage: -90 dB minimum at 3 GHz Insertion loss: .15 dB maximum at 10 GHz Insulation resistance: 5000 megohms minimum

## MECHANICAL

Mating	5/8-24 threaded coupling
Cable affixment (braid or jacket)	All crimps: hex braid crimp. Clamps: screw-thread nut and braid clamp
Cable affixment (center conductor)	Crimp: crimp or solder All others: solder only
Captivated contact	All crimps. Others, where specified.
Cable retention	Crimps: 60-120 lbs. Clamps: 30-70 lbs.

## MATERIAL

Contacts	Male: brass; Female: phosphor bronze or beryllium copper. Silver or gold plated
Other metal parts	Brass: ASTROplate® finish except M39012 silver.
Insulators	TFE, copolymer of styrene or glass-TFE (hermetic seal)
Weatherproof gaskets	Silicone rubber or synthetic rubber
Crimp ferrule	Copper

## ENVIRONMENTAL

Temperature range	TFE -65°C to + 165°C Copolymer of Styrene: - 55°C to + 85°C
Weatherproof	All series N with gaskets are weatherproof
Hermetic seals	Pass helium leak test of $2 \times 10^{-8}$ cc/sec
Pressurized Shock	Compression seal MIL-Std. 202 method 213
Vibration	MIL-Std. 202 method 204 (test cond. B)
Moisture resistance	MIL-Std. 202 method 106
Corrosion	MIL-Std. 202 method 101 (test cond. B)
Temperature cycling	MIL-Std. 202 method 102 (test cond. C)
Altitude	MIL-Std. 202 method 105 (test cond. C)

## MILITARY SPECIFICATIONS

MIL-C-39012 & MIL-A-55339	Where applicable
---------------------------	------------------

NOTE: These characteristics are typical and may not apply to all connectors.

## PLUG

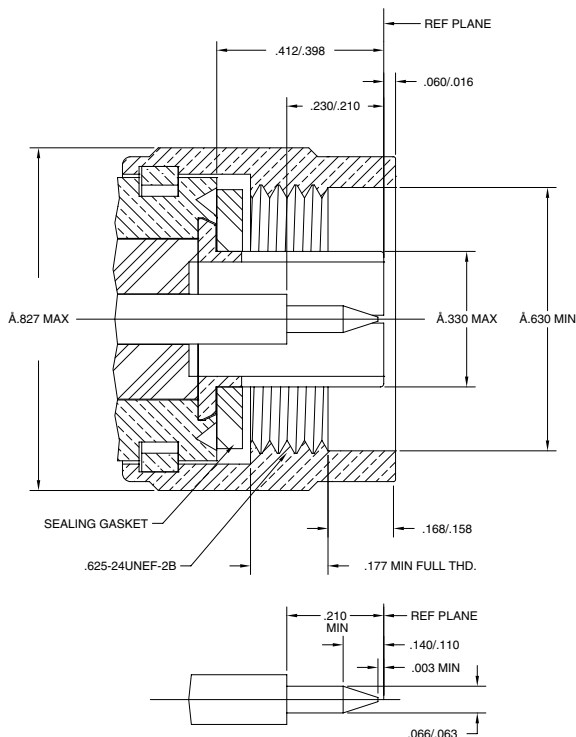

## JACK

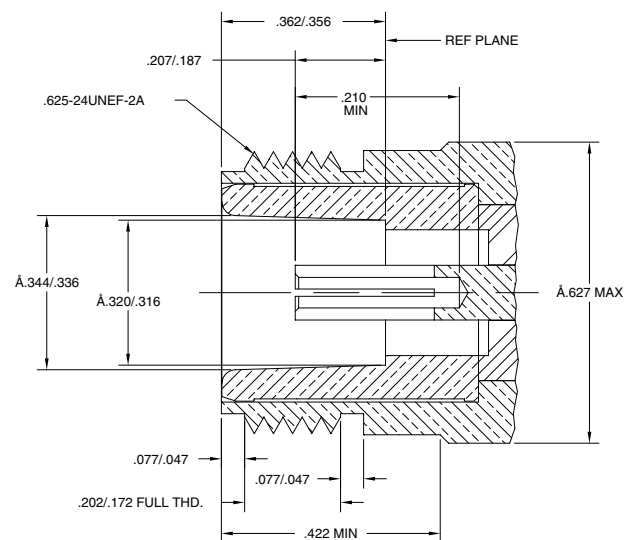

# Type N Cable Attachment Method

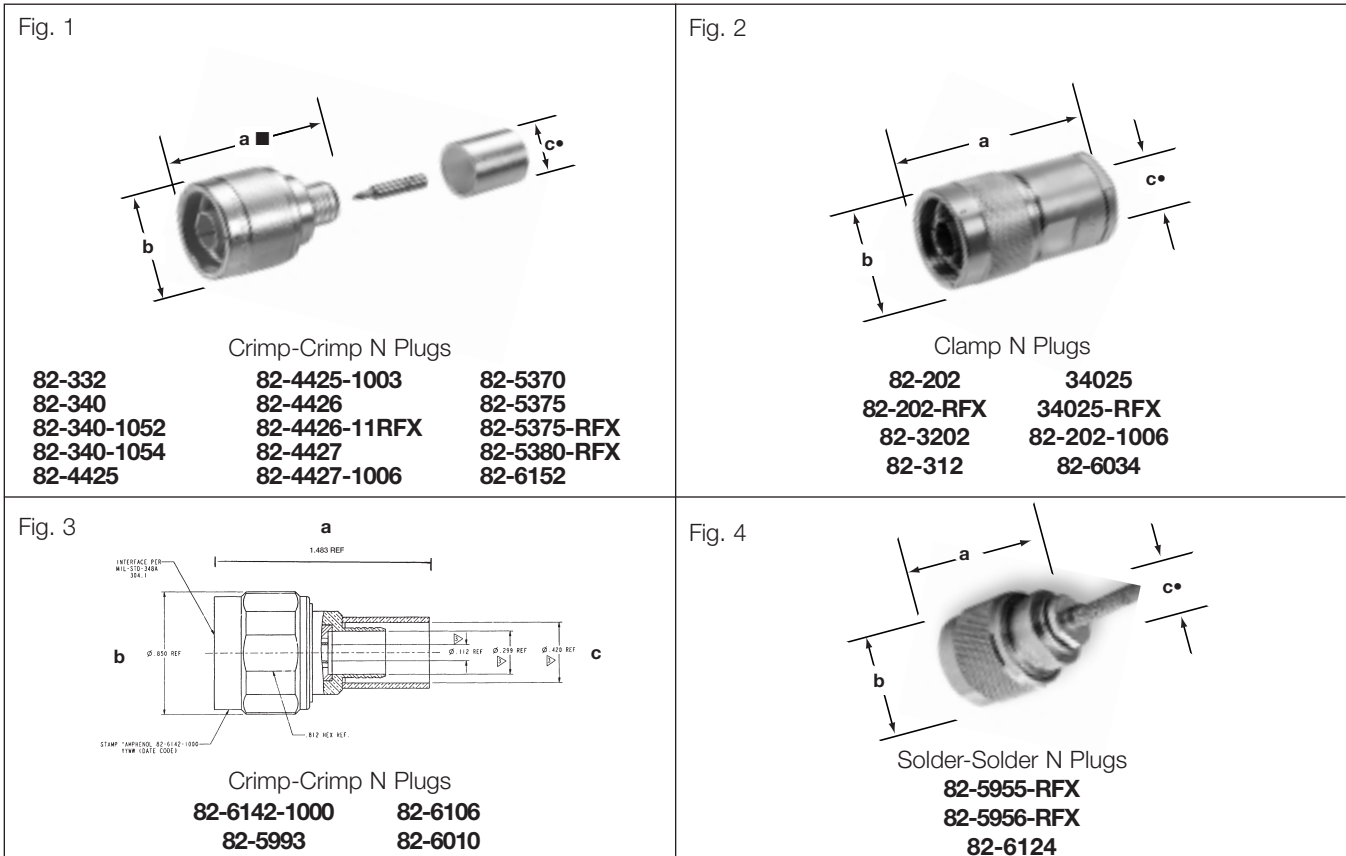

## N CABLE PLUGS

Cable RG-/U	Cable Attachment		Dimensions, inches (millimeters)			Construction Notes				Military Number	Amphenol Number	Fig.
	Outer	Inner	a	b	c •	CAI	Plt.	Ins.				
8, 213	Crimp	Crimp	1.48(37.7)■	.827(21.0)	.418(10.6)	C11	P33	D1	Lockwire Holes	M39012/01B0007	82-340	1 ▲
8, 9, 144, 165, 213	Clamp	Solder	1.50(38.1)	.827(21.0)	.444(11.3)	C8	P1	D9	Lockwire Holes	UG-21E/U	82-3202	2
	Clamp	Solder	1.50(38.1)	.827(21.0)	.444(11.3)	C8	P1	D1	Captivated Cont.	UG-1185/U	82-312	2
8, 9, 144, 165, 213, 214, 216, 225	Clamp	Solder	1.50(38.1)	.827(21.0)	.444(11.2)	C8	P1	D1	Lockwire Holes	UG-21D/U	82-202	2
	Clamp	Solder	1.50(38.1)	.827(21.0)	.437(11.1)	C8	P7	D1	—	—	82-202-RFX	2 ▲
9, 214	Crimp	Crimp	1.48(37.7)■	.827(21.0)	.438(11.1)	C11	P34	D1	Lockwire Holes	M39012/01B0008	82-332	1
9, 214, 225, 393	Crimp	Crimp	1.54(39.1)■	.827(21.0)	.438(11.1)	C11	P15	D1	—	—	82-4425-1003	1 ▲
55, 142, 223	Crimp	Crimp	1.37(34.9)■	.827(21.0)	.220(5.6)	C11	P15	D1	Lockwire Holes	—	82-5370	1
58, 141	Crimp	Crimp	1.48(37.7)■	.827(21.0)	.206(5.2)	C11	P17	D1	Lockwire Holes	—	82-5375	1
	Crimp	Crimp	1.36(34.6)■	.827(21.0)	.210(5.3)	C11	P7	D1	—	—	82-5375-RFX	1
	Clamp	Solder	1.38(34.9)■	.827(21.0)	.219(5.4)	C8	P1	D1	Lockwire Holes	UG-536B/U	34025	2
142, 142B, 400	Clamp	Solder	1.31(33.2)	.827(21.0)	.212(5.4)	C8	P7	D1	—	—	34025-RFX	2
	Clamp	Solder	1.38(35.0)■	.827(21.0)	.220(5.6)	C11	P15	D1	—	—	82-4427-1006	1
142, 400	Crimp	Crimp	1.45(36.9)■	.827(21.0)	.220(5.6)	C11	P34	D1	Lockwire Holes	M39012/01-0503	82-4427	1
213	Crimp	Crimp	1.45(36.9)■	.827(21.0)	.418(10.6)	C11	P34	D1	Lockwire Holes	M39012/01-0502	82-4426	1
214, 225, 393	Crimp	Crimp	1.45(36.9)■	.827(21.0)	.438(11.1)	C11	P33	P1	Lockwire Holes	M39012/01-0501	82-4425	1
Belden 9913, 9914	Crimp	Crimp	1.48(37.7)■	.827(21.0)	.418(10.6)	C11	P15	D1	—	—	82-340-1052	1
B9913, Amph TWB 4001	Clamp	Solder	1.50(38.1)	.827(21.0)	.443(11.2)	C8	P1	D1	—	—	82-202-1006	2
LMR400, TWB 4001	Crimp	Crimp	1.49(37.8)■	.850(21.6)	.418(10.6)	C11	P1	D9	Hex Coupling	—	82-6142-1000	3
LMR600, TWB 6001	Crimp	Crimp	1.98(50.3)■	.930(23.6)	.625(15.9)	C11	P34	D9	Hex Coupling	—	82-5993	3
LMR240, TWB 2401	Crimp	Crimp	1.41(35.8)■	.850(21.6)	.261(6.6)	C11	P15	D1	Hex Coupling	—	82-6106	3
LMR240, TWB 2401	Crimp	Preassy	1.41(35.8)■	.850(21.6)	.261(6.6)	C11	P34	D1	Hex Coupling	—	82-6010	3
59, 62	Crimp	Crimp	1.36(34.6)■	.827(21.0)	.261(6.6)	C11	P7	D1	—	—	82-5380-RFX	1
174, 188, 316	Crimp	Crimp	1.41(35.8)■	.827(21.0)	.125(3.2)	C11	P7	D1	—	—	82-6034	3
LMR 240, TWB2401	Crimp	Crimp	1.17(29.8)	.827(21.0)	.220(5.6)	C11	P7	D1	—	—	82-6152	1
402 (.141 S/R)	Solder	Solder	1.19(30.3)	.826(21.0)	.141(3.6)	C9	P7	D1	—	—	82-5955-RFX	4
405 (.086 S/R)	Solder	Solder	1.19(30.3)	.826(21.0)	.086(2.2)	C9	P7	D1	—	—	82-5956-RFX	4
401 (.250 S/R)	Solder	Solder	1.19(30.3)	.826(21.0)	.250(6.35)	C9	P7	D1	—	—	82-6124	4
Ethernet® Cables Times AA4478(FEP), AA4479(PVC); Belden 89880(FEP), 9880(PVC)	Crimp	Crimp	1.48(37.7)■	.827(21.0)	.437(11.1)	C11	P7	D1	—	—	82-4426-11RFX	1

● accommodates cable diameter ■ includes outer ferrule ▼ Ethernet = Xerox Trademark ▲ Distributor stocked

Type N

Fig. 1

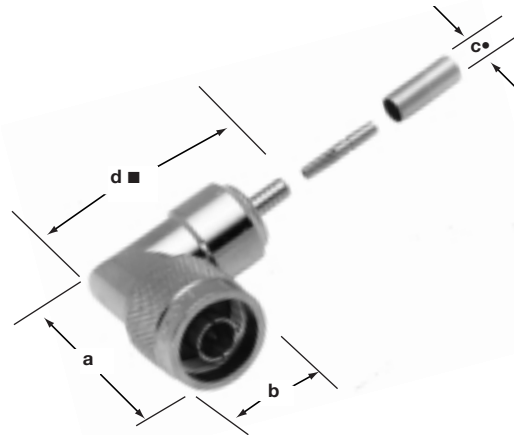

Crimp N Angle Plugs  
**82-4440-1001 82-5995**  
**82-5374 82-4440**

Fig. 2

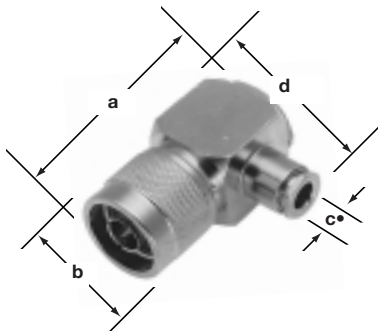

Clamp N Angle Plug  
 Cubic Body  
**18750**  
**82-5988-1000**

Fig. 3

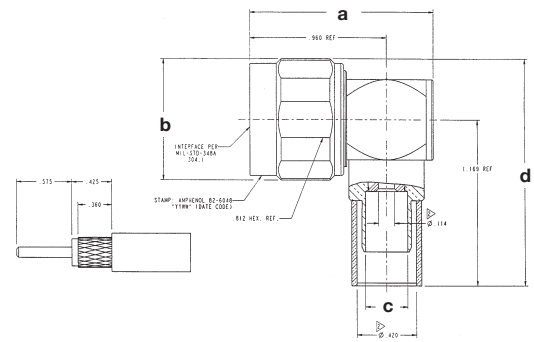

Crimp N Angle Plug  
 Cubic Body  
**82-6048-1000**  
**82-5989-1004**  
**82-6157**  
**82-6165**  
**82-6166**

## N RIGHT ANGLE PLUGS

Cable RG-/U	Cable Attachment		Dimensions, inches (millimeters)				Notes			Military Number	Amphenol Number	Fig.
	Outer	Inner	a	b	c •	d	CAI	Pit.	Ins.			
<b>9, 214, 225, 393</b>	Crimp	Crimp	1.40(35.5)	.827(21.0)	.437(11.1)	1.95(49.5)■	C11	P28	D1	—	<b>82-4440-1001</b>	1
<b>55, 142, 223</b>	Crimp	Crimp	1.41(35.7)	.827(21.0)	.220(5.6)	1.98(50.2)■	C11	P11	D1	—	<b>82-5374</b>	1 ▲
<b>58, 141, 142</b>	Clamp	Solder	1.63(41.3)	.827(21.0)	.210(5.3)	1.22(31.0)	C8	P1	D1	—	<b>18750</b>	2
<b>214, 225, 393</b>	Crimp	Crimp	1.40(35.5)	.827(21.0)	.438(11.1)	1.95(49.5)■	C11	P33	D1	M39012/05-0501	<b>82-4440</b>	1 ▲
<b>214, 393</b>	Crimp	Solder	1.195(30.4)	.827(21.0)	.438(11.1)	1.62(4.1)■	C11	P33	D9	—	<b>82-5988-1000</b>	2
<b>214, 393</b>	Crimp	Solder	1.195(30.4)	.850(21.6)	.438(11.1)	1.62(4.1)■	C11	P33	D9	Hex Coupling	<b>82-5988-1004</b>	3
<b>LMR 600, TWB 6001</b>	Crimp	Solder	1.32(33.5)	.850(21.6)	.625(15.9)	1.61(40.9)■	C11	P34	D9	Hex Coupling	<b>82-5995</b>	1
<b>Amph TWB 4001, LMR 400, Belden 9913</b>	Crimp	Solder	1.291(32.8)	.850(21.6)	.298(7.57)	1.594(40.5)■	C11	P33	D9	—	<b>82-6048-1000</b>	3
<b>LMR 240, 8X</b>	Crimp	Crimp	1.43(36.5)	.827(21.0)	.259(6.6)	1.07(27.2)	C11	P7	D1	—	<b>82-6157</b>	3
<b>LMR 240, 8X</b>	Crimp	Crimp	1.43(36.5)	.827(21.0)	.259(6.6)	1.07(27.2)	C11	P7	D1	—	<b>82-6165</b>	3
<b>LMR 240, 8X</b>	Crimp	Crimp	1.43(36.5)	.827(21.0)	.259(6.6)	1.07(27.2)	C11	P33	D1	—	<b>82-6166</b>	3

• accommodates cable diameter ■ includes outer ferrule ▲ Distributor stocked

# Type N Straight Jacks

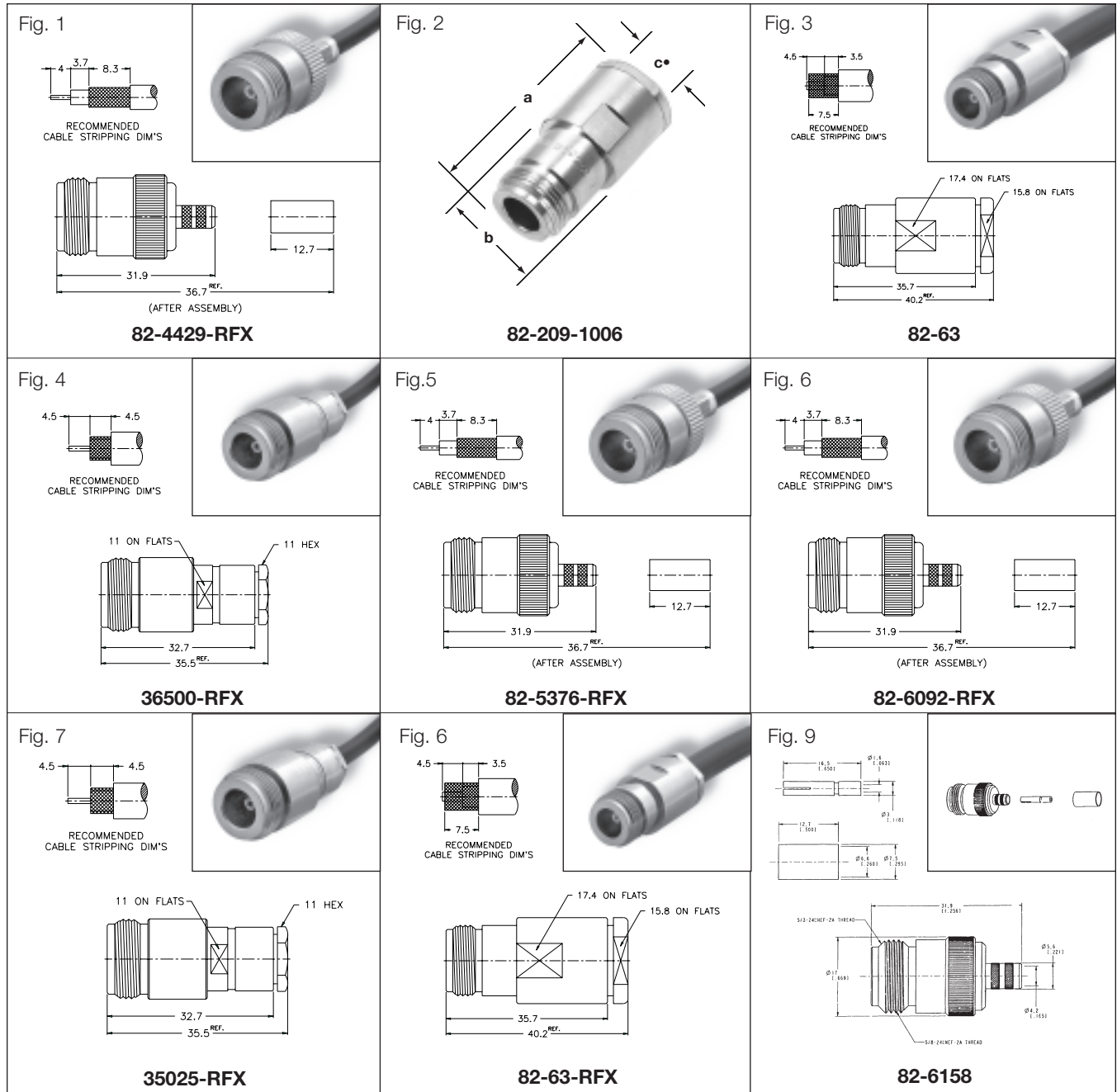

## N STRAIGHT JACKS

Cable RG-/U	Conn. Type	Cable Attachment		Dimensions, inches (millimeters)					Notes			Military Number	Amphenol Number	Fig	
		Outer	Inner	a	b	c •	d	e	CAI	Pft.	Ins.				
8, 9, 87A, 144,165,213, 214,216,225	Str.	Clamp	Solder	1.56(39.7)	.750(19.1)	.440(11.2)	—	—	C8	P1	D1	UG-23B/U	82-63	3	▲
B9913, Times AA-6146	Str.	Clamp	Solder	1.56(39.6)	.750(19.1)	.443(11.3)	—	—	C8	P1	D9	—	82-209-1006	2	
59, 62	Str.	Crimp	Crimp	1.44 (36.7)	.866 (22)	.210 (5.3)	.866 (22)	.250 (64)	—	P7	D1	—	82-5376-RFX	5	
58, 141	Str.	Crimp	Crimp	1.44 (36.7)	—	—	—	—	—	P7	D1	—	82-6092-RFX	6	▲
58, 141	Str.	Clamp	Solder	1.90 (35.5)	.630 (16)	.212 (5.4)	—	—	—	P7	D1	—	35025-RFX	7	▲
8, 213, 214	Str.	Clamp	Solder	1.58 (40.2)	.750 (19)	.437 (11.1)	—	—	—	P7	D1	—	82-63-RFX	8	
59, 62	Str.	Clamp	Solder	.96 (24.5)	.827 (21)	.143 (3.6)	—	—	—	P7	D1	—	36500-RFX	4	
LMR240, 8X	Str.	Clamp	Solder	.96 (24.5)	.827 (21)	.143 (3.6)	—	—	—	P7	D1	—	82-6158	9	
LMR240, 8, 213	Str.	Crimp	Crimp	.96 (24.5)	.827 (21)	.143 (3.6)	—	—	—	P7	D1	—	82-4429-RFX	1	

• accommodates cable diameter ■ Captivated contact ★ IBM6028495 ▼ max. panel when rear mounted thru panel ▲ Distributor stocked

# Type N Panel Mount - 4 Hole Flange

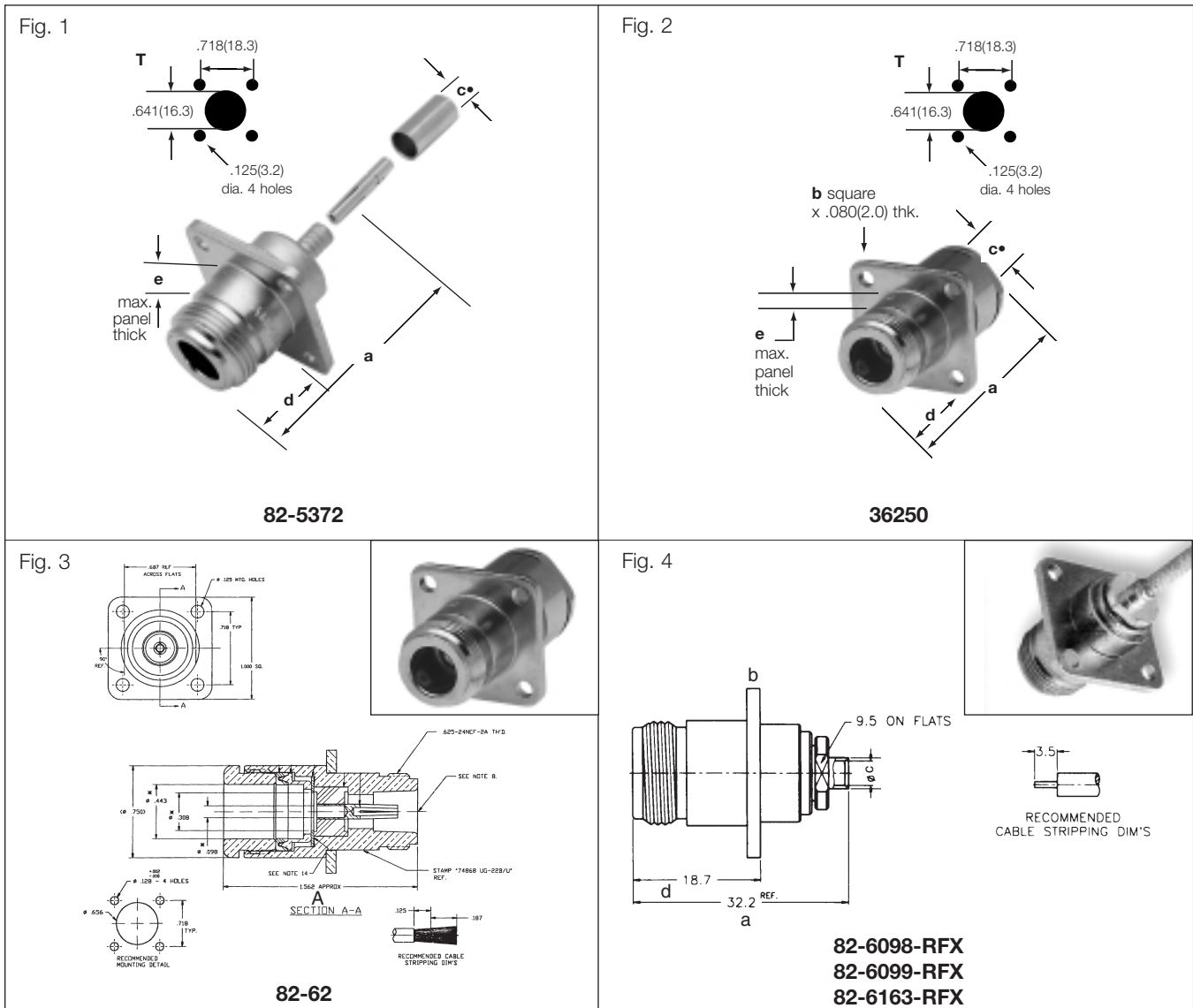

## N PANEL JACKS

Cable RG-/U	Conn. Type	Cable Attachment Outer	Cable Attachment Inner	Dimensions, inches (millimeters)					Notes			Mtg Hole	Military Number	Amphenol Number	Fig
				a	b	c •	d	e	CAI	Plt.	Ins.				
55, 141, 142	Panel	Crimp	Crimp	1.56(39.7)	1.00(25.4)	.220(5.6)	.576(14.6)	.125(3.2)▼	C11	P15	D1	T	—	82-5372	2
55, 58, 141,	Panel	Clamp	Solder	1.50(38.1)	1.00(25.4)	.224(5.7)	.656(16.7)	.219(5.6)▼	C8	P1	D1	T	UG-1095A/U	36250	1
8, 9, 87A, 144,165,213, 214,216,225	Panel	Clamp	Solder	1.56(39.7)	1.00(25.4)	.440(11.2)	—	—	C8	P1	D1	—	UG-23B/U	82-62	3
405 (.085) S/R	Panel	Solder	Solder	1.26(32.2)	1.00(25.4)	.086(2.2)	.736(18.7)	—	C9	P7	D1	T	—	82-6098-RFX	4
402 (.141) S/R	Panel	Solder	Solder	1.26(32.2)	1.00(25.4)	.141(3.6)	.736(18.7)	—	C9	P7	D1	T	—	82-6099-RFX	4
401 (.250) S/R	Panel	Solder	Solder	1.26(32.2)	1.00(25.4)	.250(6.35)	.736(18.7)	—	C9	P7	D1	T	—	82-6163-RFX	4



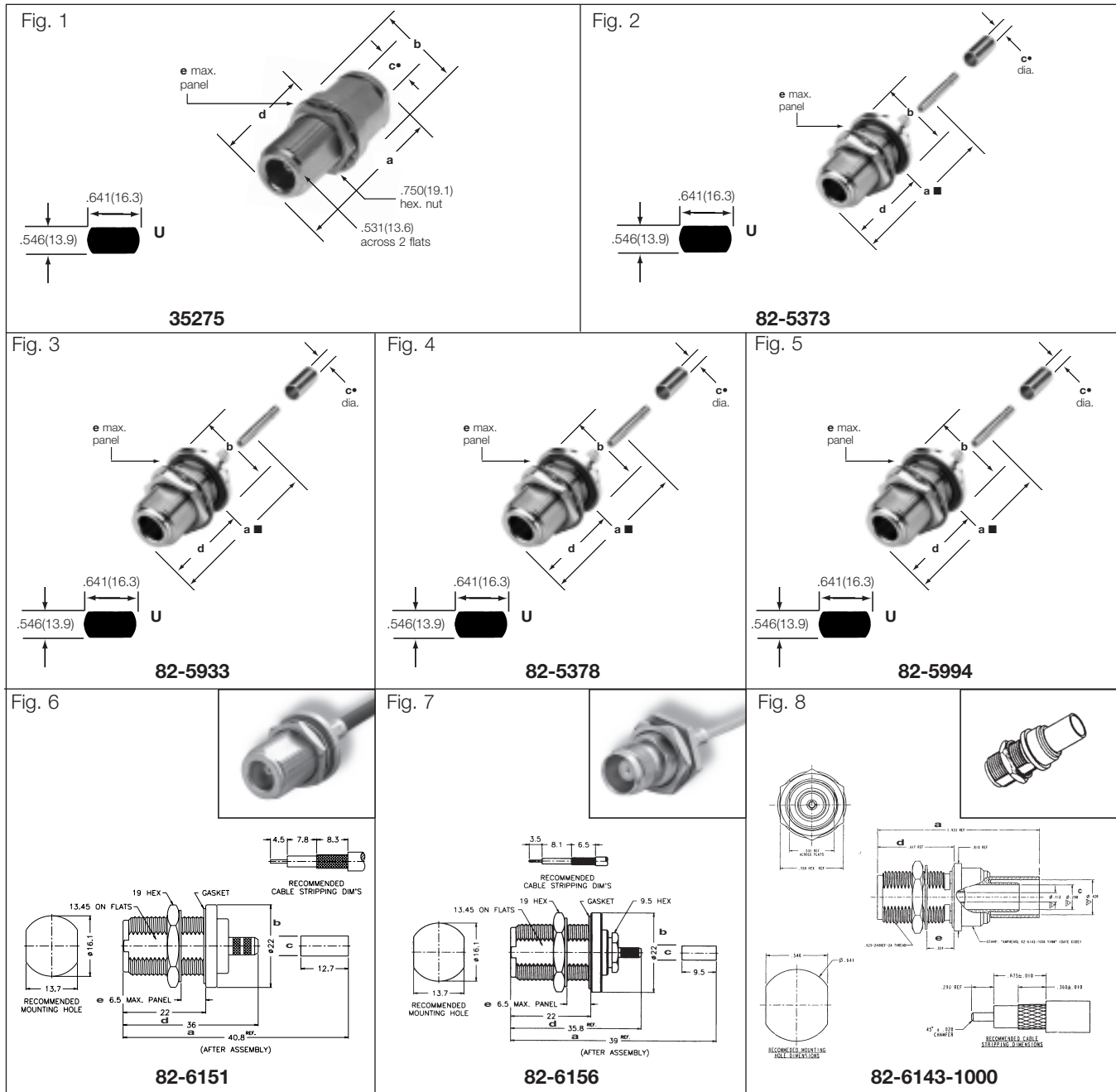

## N BULKHEAD JACKS

Cable RG-/U	Conn. Type	Cable Attachment		Dimensions, inches (millimeters)					Notes			Mtg Hole	Military Number	Amphenol Number	Fig
		Outer	Inner	a	b	c •	d	e	CAI	Plt.	Ins.				
55, 58, 141, 142, 223	Bulkh.	Clamp	Solder	1.67(42.5)	.813(20.6)	.224(5.7)	.910(23.1)	.317(8.1)	C8	P1	D1	U	UG-556B/U	35275	1
55, 142, 223	Bulkh.	Crimp	Crimp	1.84(46.8)	.875(22.2)	.220(5.6)	.935(23.7)	.250(6.4)	C11	P15	D1	U	—	82-5373	2
188, 316	Bulkh.	Solder	Crimp	1.59(40.4)	.866(22.0)	.178(4.5)	.917(23.3)	.315(8.0)	C11	P15	D9	U	—	82-5933	3
58, 141	Bulkh.	Crimp	Crimp	1.74(44.2)	.872(22.1)	.206(5.2)	.926(23.5)	.250(6.4)	C11	P34	D1	U	—	82-5378	4
LMR 600	Bulkh.	Crimp	Crimp	2.21(56.1)	.933(23.7)	.625(15.9)	.926(23.5)	.250(6.4)	C11	P34	D9	U	—	82-5994	5
LMR 240, 8X	Bulkh.	Crimp	Crimp	1.41(36.0)	.866(22.0)	.259(6.6)	.866(22.0)	.255(6.5)	C11	P7	D1	—	—	82-6151	6
174, 188, 316	Bulkh.	Crimp	Crimp	1.53(39.0)	.866(22.0)	.133(3.4)	.866(22.0)	.255(6.5)	C11	P7	D1	—	—	82-6156	7
LMR 400	Bulkh.	Crimp	Crimp	1.93(49.0)	.750(19.0)	.420(10.6)	.917(23.2)	.324(8.22)	C11	P34	D9	U	—	82-6143-1000	8

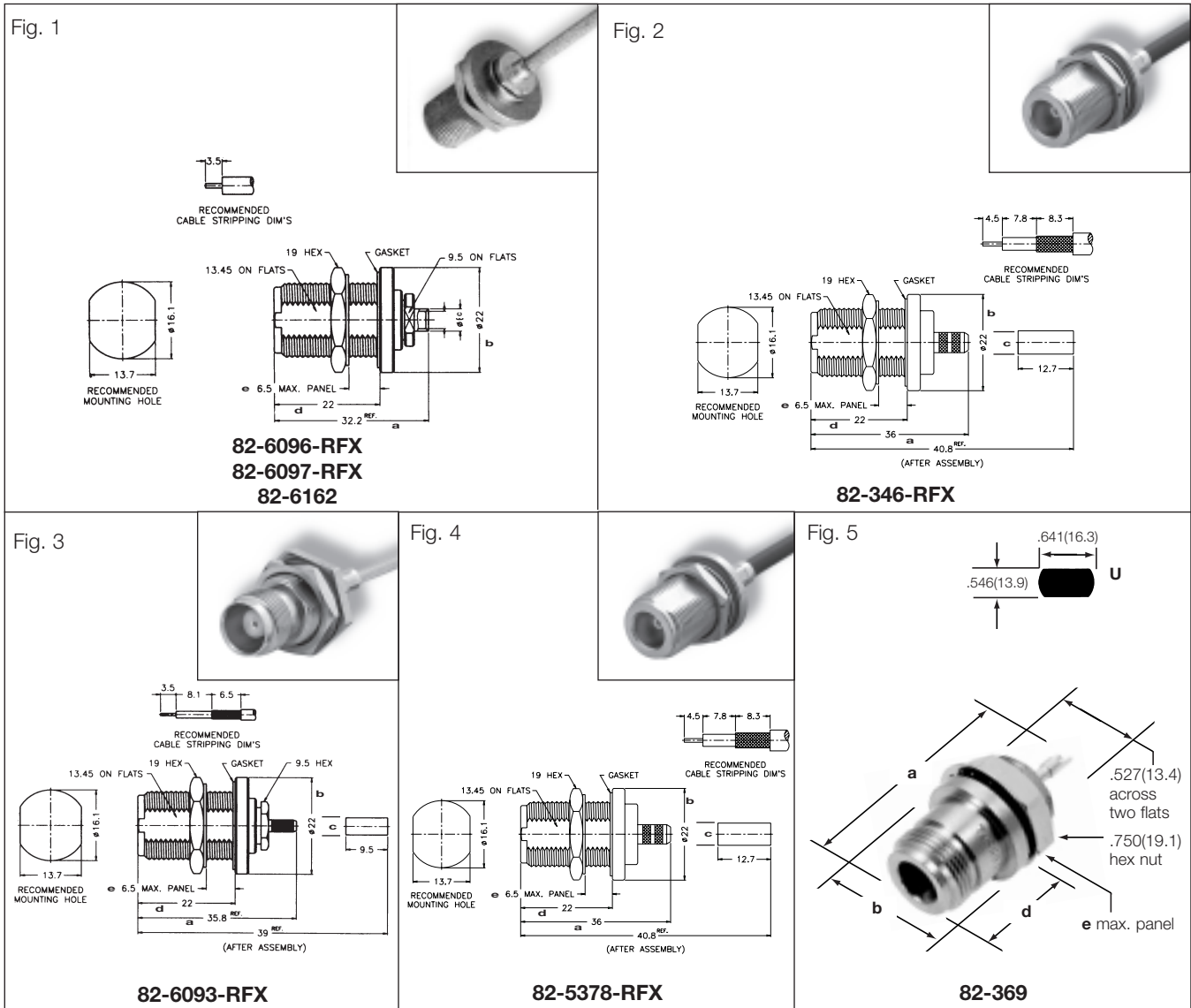

## N BULKHEAD JACKS

Cable RG-/U	Cable Attachment		Dimensions, inches (millimeters)					Notes			Mtg Hole	Military Number	Amphenol Number	Fig
	Outer	Inner	a	b	c •	d	e	CAI	Pit.	Ins.				
405 (.085) S/R	Solder	Solder	1.26(32.2)■	.866(22.0)	.086(2.2)	.866(22.0)	.255(6.5)	C9	P7	D1	—	—	82-6096-RFX	1
402 (.141) S/R	Solder	Solder	1.26(32.2)■	.866(22.0)	.141(3.6)	.866(22.0)	.255(6.5)	C9	P7	D1	—	—	82-6097-RFX	1
401 (.250) S/R	Solder	Solder	1.26(32.2)■	.866(22.0)	.250(6.3)	.866(22.0)	.255(6.5)	C9	P7	D1	—	—	82-6162	1
8, 213	Crimp	Crimp	1.41(36.0)■	.866(22.0)	.165(4.2)	.866(22.0)	.255(6.5)	C11	P7	D1	—	—	82-346-RFX	2
174, 188, 316	Crimp	Crimp	1.40(35.8)■	.866(22.0)	.126(3.2)	.866(22.0)	.255(6.5)	C11	P7	D1	—	—	82-6093-RFX	3
58, 141	Crimp	Crimp	1.40(35.8)■	.866(22.0)	.210(5.3)	.866(22.0)	.255(6.5)	C11	P7	D1	—	—	82-5378-RFX	4

## N PANEL, ANGLE PANEL & BULKHEAD RECEPTACLES

Description	Terminal Type	Dimensions, inches (millimeters)				Pit.	Ins.	Mtg Hole	Military Number	Amphenol Number	Fig.
		a	b	d	e						
Bulkhead Receptacle (Jack) Front Mount, Hermetically Sealed	Solder Cup	1.58(40.1)	.813(20.6)	.707(18.0)	.209(5.3)	P34	D11	U	M39012/04-0001	82-369	5

# Type N Panel Mount Receptacle / Solder Terminal

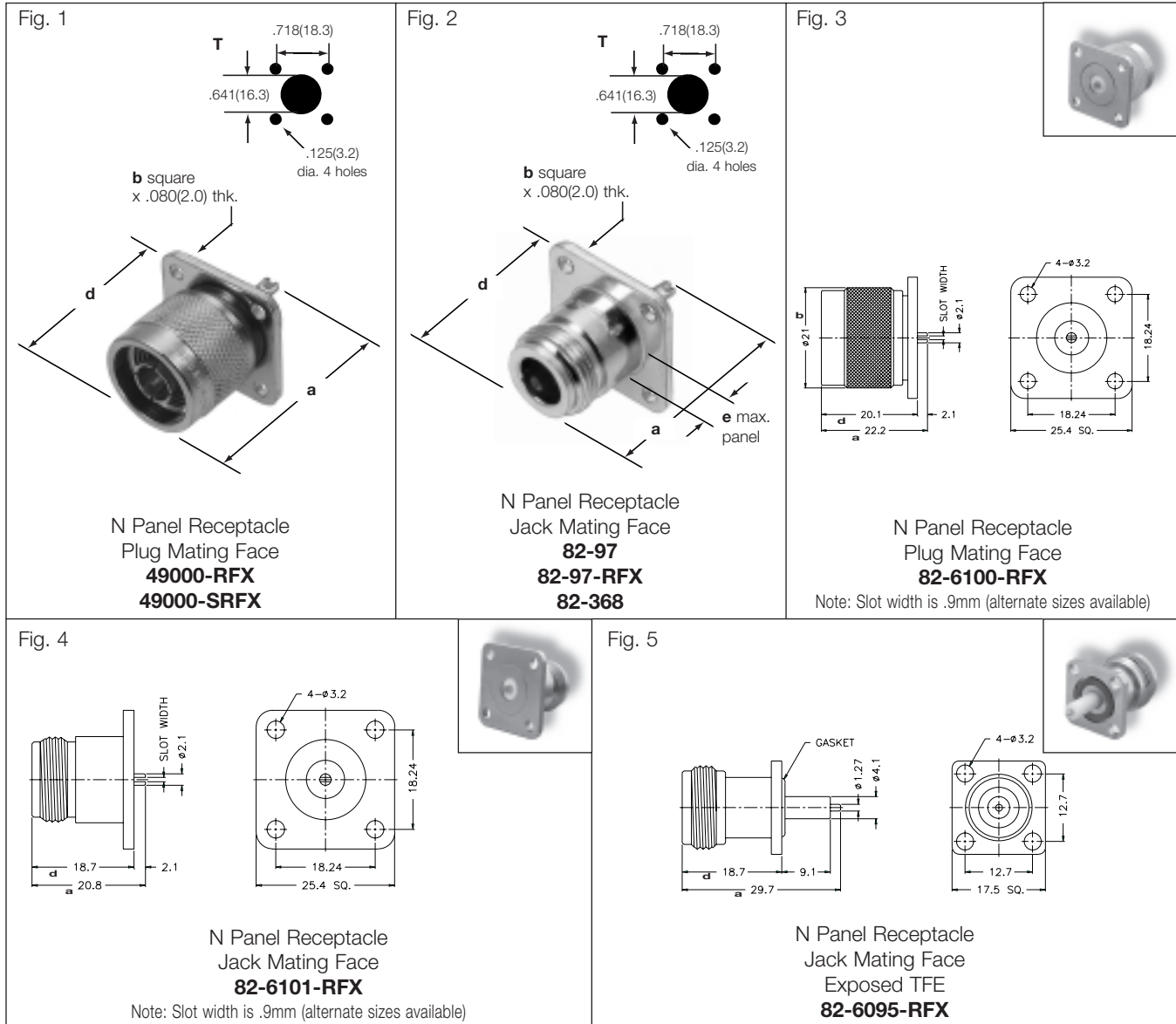

## N PANEL, ANGLE PANEL & BULKHEAD RECEPTACLES

Description	Terminal Type	Dimensions, inches (millimeters)				Plt.	Ins.	Mtg Hole	Military Number	Amphenol Number	Fig.
		a	b	d	e						
Panel Receptacle (Jack) 4-hole Square Flange, Front or Rear Mount	Solder Cup	1.11(28.2)	1.00(25.4)	.656(16.7)	.187(4.7)▼	P1	D1	T	UG-58A/U	<b>82-97</b>	2 ▲
	Solder Cup	1.13(28.7)	1.00(25.4)	.656(16.7)	.187(4.7)▼	P7	D1	T	—	<b>82-97-RFX</b>	2 ▲
	Solder Cup	1.11(28.2)	1.00(25.4)	.656(16.7)	.187(4.7)▼	P34	D1	T	M39012/04-0002	<b>82-368</b>	2
Panel Receptacle (Plug) 4-hole Square Flange, Front Mount Only	Solder Cup	1.09(27.8)	1.00(25.4)	.745(18.9)	—	P7	D6	T	—	<b>49000-RFX</b>	1
Panel Receptacle (Plug) 4-hole Square Flange, Front Mount Only	Solder Cup	1.09(27.8)	1.00(25.4)	.745(18.9)	—	P33	D6	T	—	<b>49000-SRFX</b>	1
Panel Receptacle (Plug) 4-hole Square Flange, Front Mount Only	Slotted Post	.874(22.2)	.826(21.0)	.791(20.1)	—	P7	D1	—	—	<b>82-6100-RFX</b>	3
Panel Receptacle (Jack) 4-hole Square Flange, Slot Terminal	Slotted Post	.818(20.8)	—	.736(18.7)	—	P7	D1	—	—	<b>82-6101-RFX</b>	4
Panel Receptacle (Jack) 4-hole Square Flange, Exposed TFE	Exposed TFE	1.16(29.7)	—	.736(18.7)	—	P7	D1	—	—	<b>82-6095-RFX</b>	5

# Type N Adapters, Straight

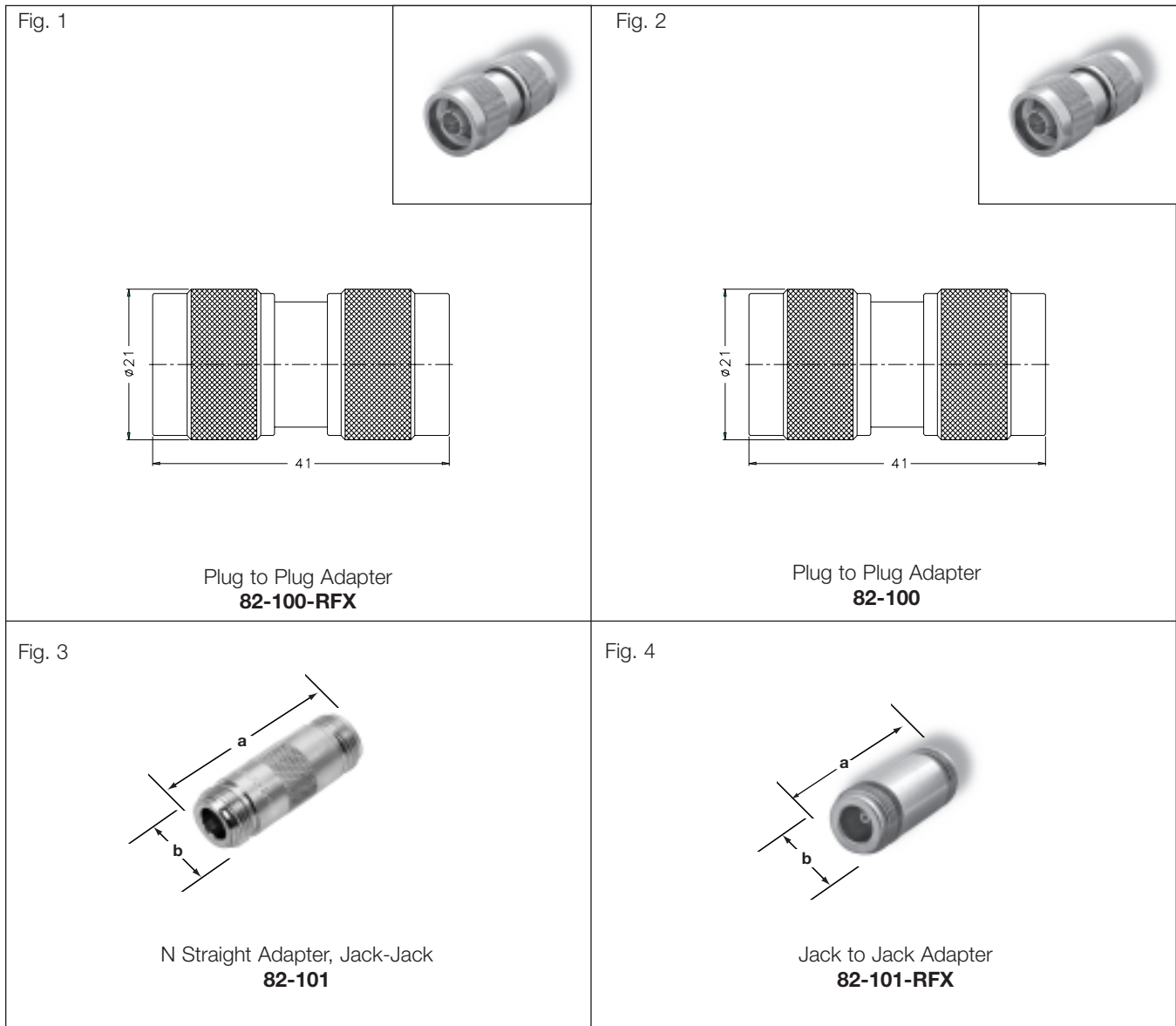

## N ADAPTERS

Adapter Ends	Description	Dimensions, inches (millimeters)				Mtg Hole	Construction Notes			Military Number	Amphenol Number	Fig.
		a	b	d	e		Plt.	Ins.	Other			
Plug-Plug	Straight	1.59(40.5)	.813(20.6)	—	—	—	P4	D1	—	UG-57B/U	<a href="#">82-100</a>	1
Plug-Plug	Straight	1.59(40.5)	.813(20.6)	—	—	—	P7	D1	—	UG-57B/U	<a href="#">82-100-RFX</a>	2
Jack-Jack	Straight	1.78(45.2)	.656(16.7)	—	—	—	P1	D1	—	UG-29B/U	<a href="#">82-101</a>	3
Jack-Jack	Straight	1.50(38.1)	.620(15.8)	—	—	—	P1	D1	—	UG-29B/U	<a href="#">82-101-RFX</a>	4

▲ Distributor stocked

# Type N Adapters, Bulkhead/Angle & Tee

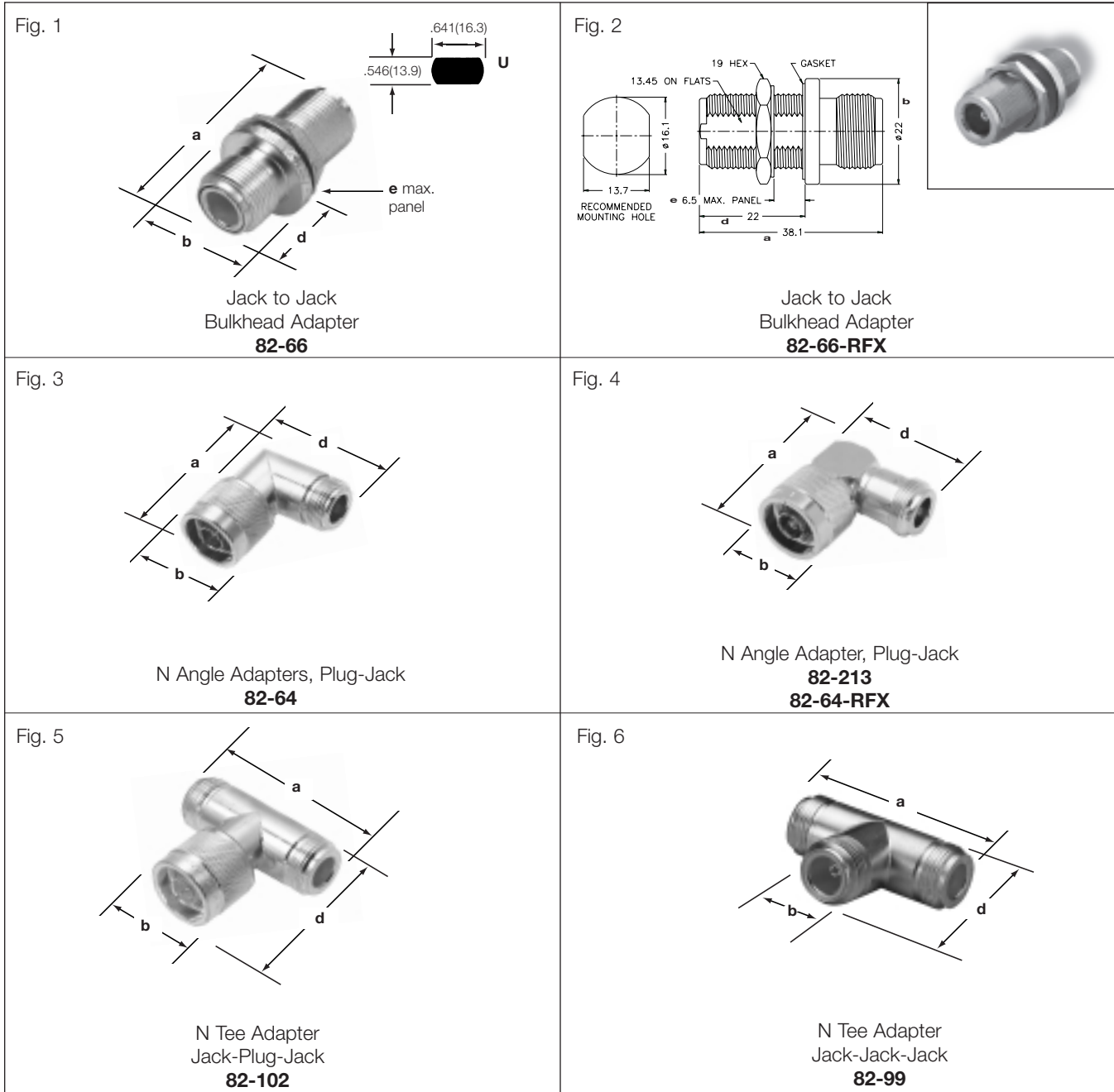

## N ADAPTERS

Adapter Ends	Description	Dimensions, inches (millimeters)				Mtg Hole	Construction Notes			Military Number	Amphenol Number	Fig.
		a	b	d	e		Plt.	Ins.	Other			
Jack-Jack	Bulkhead	1.63(41.3)	.813(20.6)	.708(18.0)	.312(7.9)	U	P1	D6	Pressurized	UG-30/U	<a href="#">82-66</a>	1 ▲
Jack-Jack	Bulkhead	1.50(38.1)	.866(22.0)	.866(22.0)	.256(6.5)	U	P1	D6	Pressurized	UG-30/U	<a href="#">82-66-RFX</a>	2 ▲
Jack-Plug	Angle	1.44(36.5)	.813(20.6)	1.37(34.9)	—	—	P1	D1	Mitre Body	UG-27A/U	<a href="#">82-64</a>	3 ▲
Plug-Jack	Angle	1.44(36.5)	.813(20.6)	1.28(32.5)	—	—	P7	D1	Cubic Body	—	<a href="#">82-64-RFX</a>	4 ▲
Plug-Jack	Angle	1.31(33.3)	.813(20.6)	1.40(35.7)	—	—	P1	D1	Cubic Body	UG-27C/U	<a href="#">82-213</a>	4 ▲
Jack-Plug-Jack	Tee	1.75(44.5)	.813(20.6)	1.48(37.6)	—	—	P5	D1	—	UG-107B/U	<a href="#">82-102</a>	5
Jack-Jack-Jack	Tee	1.75(44.5)	.656(16.7)	1.22(31.0)	—	—	P5	D1	—	UG-28A/U	<a href="#">82-99</a>	6

▲ Distributor stocked

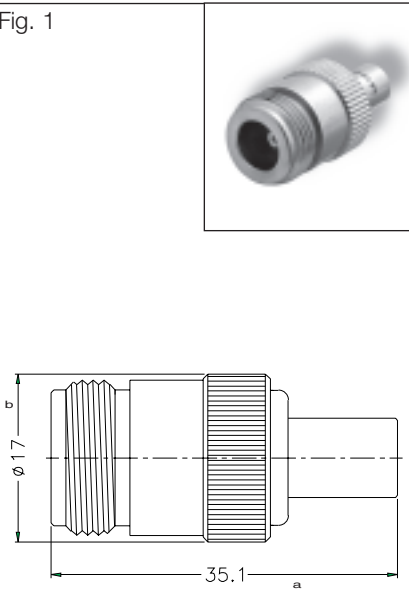
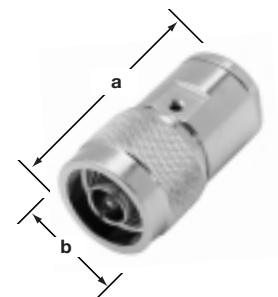
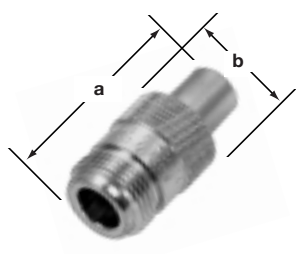
<p>Fig. 1</p>  <p>N Terminator Jack <b>82-5721-10RFX</b></p>	<p>Fig. 2</p>  <p>N Male Cap / Resistor Terminated <b>82-5722-RFX</b></p>	<p>Fig. 3</p>  <p>N Female Cap / Resistor Terminated <b>82-5721-1000</b></p>
---	--	---

## N CAPS

Description	Dimensions, inches (millimeters)		Plt.	Ins.	Military Number	Amphenol Number	Fig.
	a	b					
Male Cap Resistor Terminated, 50Ω 5%, 1 Watt	1.30(33.0)	.827(21.0)	P7	D1	—	<b>82-5722-RFX</b>	2
Female Cap Terminator, 49.9Ω 1%, 1 Watt	1.30(33.0)	.656(15.7)	P17	D1	—	<b>82-5721-1000</b>	3
Female Cap Terminator, 50.0Ω 5%, 1 Watt	1.30(33.0)	.656(15.7)	P17	D1	—	<b>82-5721-10RFX</b>	1

▼ max. panel when rear mounted thru panel ▲ Distributor stocked

## Description

Intermodulation Distortion (IMD) is of increasing concern to many Wireless Infrastructure OEMs due to the need for higher power applications and increased receiver sensitivity performance. Having the ability to measure IMD in-house gives Amphenol the unique ability to understand the affects of our connector designs on IMD generation and enabling Amphenol to design the highest performance IMD connectors in the industry.

Our new series of Low Intermodulation N connectors is a result of our efforts in connector design optimization.

## Features/Benefits

- Typical IMD -125 dBm
- All components silver plated
- 360° outer contacts
- Gold plated inner contacts
- EZ HEZ™ coupling nut for ease of installation
- Available for 1/4", 3/8" and 1/2" superflexible corrugated cables, and 1/2", 7/8", 1 1/4", 1 5/8", standard flexible corrugated cables
- Consult your Amphenol sales representative for details

## Applications

- Cellular
- PCS
- Microwave Radio
- Paging



## Annular Type N

Specifications	239
Plugs and Jacks	240-243

# Type N Corrugated Cable Connectors

RF coaxial connectors are the most important element in your cable system. Corrugated copper coaxial cables have the potential to deliver all the performance your system requires, but they are often limited by the performance of the connectors. TXL coaxial connectors have been designed from the ground up to deliver optimum performance, while retaining ease of installation.

Intermodulation distortion, a major concern in today's communications systems, is consistently low with TXL connectors. Typical performance is -125 dBm (-168 dBc). In-house IMD measurement capability gives Amphenol the unique ability to understand the effects of connector design elements on IMD generation and to design the best performing connectors in the industry.

Self-flaring designs are easily attached with standard hand tools in the field, and are highly resistant to pull off and twist off.

All TXL coaxial connectors are optimally matched to their cables for low VSWR and insertion loss.

### Two-Piece Design

All TXL connectors feature a simple two-piece design for easier attachment, and all connectors for a given size share a common back nut and trimming dimensions.

### Easy-Hex Coupling Nut

Unique coupling nut design allows tightening by hand or with a standard wrench.

### One-Piece Body

Many TXL connectors feature one-piece bodies. The outer conductor contact and connector body are a single piece to minimize IMD generation.

### Plated Surfaces

Center contacts are gold or silver plated. Bodies are white bronze plated for excellent IMD performance, and are corrosion resistant for a long, trouble-free life.

### Pre-assembled O-Rings

O-rings are pre-assembled to the back nuts, eliminating installation problems and lost parts.

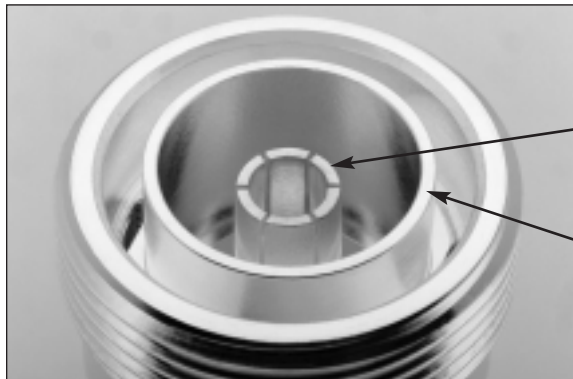
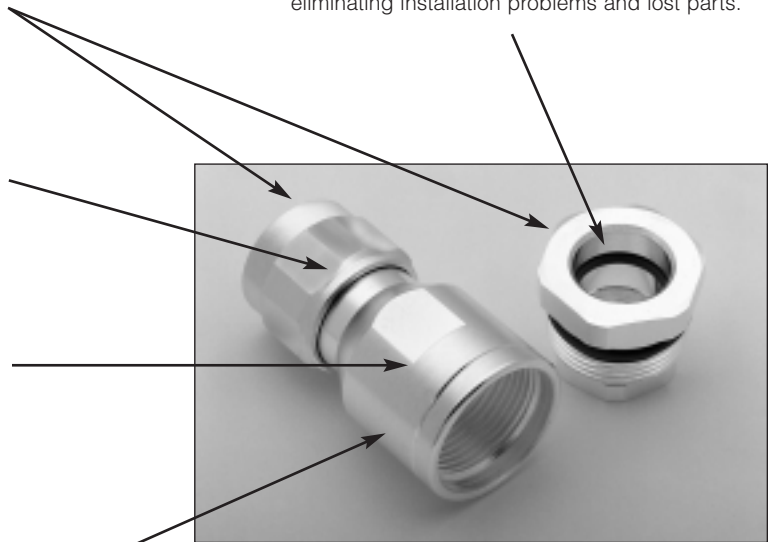

### Captive Center Pins

Captive center pins simplify installation and eliminate performance variations due to soldering errors and incorrect pin depths.

### 360° Contact

Continuous 360° outer conductor contact is proven to minimize IMD generation compared to spring finger contacts.



# Type N - Corrugated Specifications

## ELECTRICAL

Impedance	50 ohms
Frequency range	11.0 GHz
Return Loss (Freq. GHz)	33 dB (1-2 GHz) 28 dB (2-3 GHz)
Operating voltage	max. 707 vrms
Dielectric withstanding voltage	2,000 vdc
Other	Peak power: max 10kW Avg. power: max .60kW Insulation resistance: min 5,000 MOhms Insertion loss: .05 freq GHz Shielding effectiveness: min. 125 dB 3rd order IM product, typical -125 dBm (-168 dBc)

## MECHANICAL

Mating	MIL-Std. 348
Inner attachment method	Solder or captivated
Outer attachment method	Compression
Assembly torque	18/22 lb-ft (25/30 N-m)
Coupling torque	15.00 lb-in (1.70 N-m)
Coupling nut retention force	100.00 lbs (444.80 N)
Connector durability	500 cycles, 12 cycles/min

## MATERIAL

Body	Brass, silver plated
Contacts	Outer: Brass, silver plated Inner: BeCu, gold plated
Other metal parts	Brass; silver plated
Insulators	TFE
Gaskets	Silicone rubber

## ENVIRONMENTAL

Temperature range	Operating: -40°C to +150°C Storage: -70°C to +100°C
Thermal Shock	MIL-Std. 202 method 107 (test cond. A-1)
Immersion	IEC 529, IP68
Vibration	MIL-Std. 202 method 204 (test cond. B)
Corrosion	MIL-Std. 202 method 101 (test cond. B)
Mechanical Shock	MIL-Std. 202 method 213 (test cond. I)

\* These characteristics are typical and may not apply to all connectors.

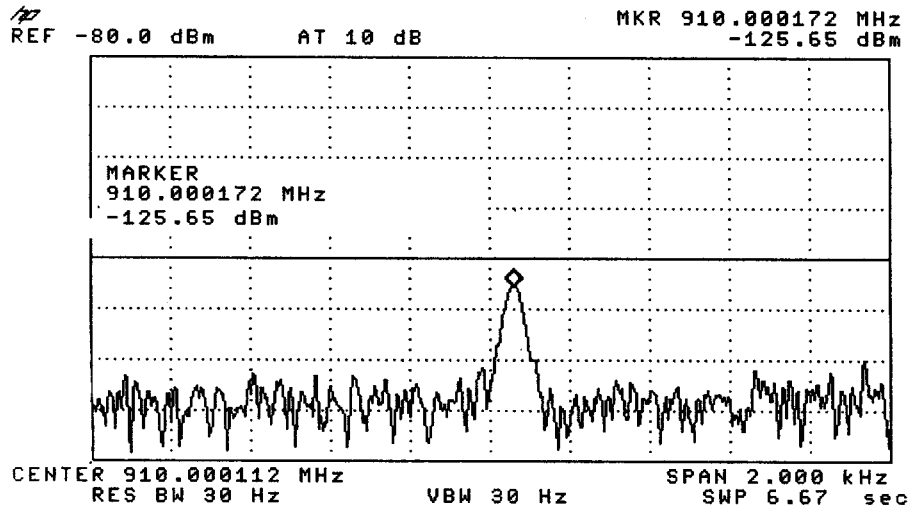

- |                                    |  |  |                       |  |  |
|------------------------------------|--|--|-----------------------|--|--|
| <b>S</b><br>Corrugated Cable       | <b>1</b><br>Cable Diameter                                   | <b>W</b><br>Plating                                | <b>N</b><br>Interface | <b>M</b><br>Gender   | <b>PM</b><br>Options   |
| S=Superflex (helical)<br>A=Annular | 1=1/4"<br>2=3/8"<br>4=1/2"<br>5=7/8"<br>6=1-1/4"<br>7=1-5/8" | W=White Bronze<br>P=Plated Body<br>(none)=Unplated | N=Type N              | M=Male (plug)<br>F=Female (jack)<br>R=Right Angle<br>Male (plug) | PM=Panel Mount<br>PM-SO=Panel Mount-<br>Slotted Outer<br>U=Universal |

Type N

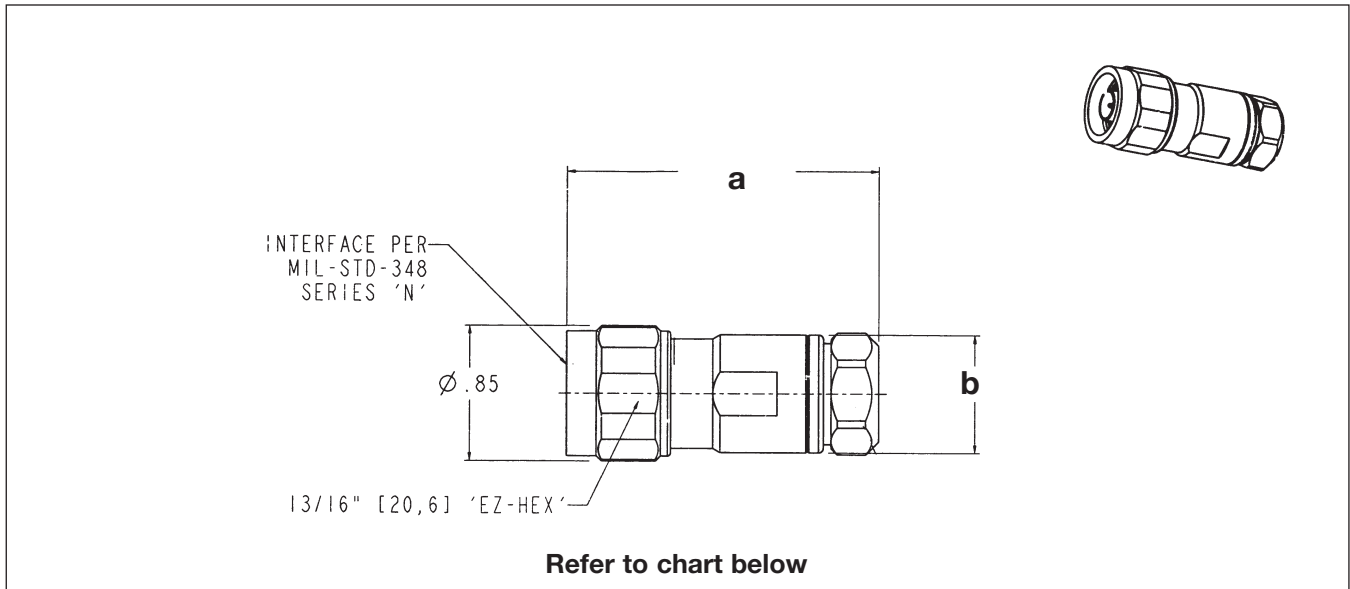

## N PLUG INTERFACE — STRAIGHT

Cable	Inner Attachment	a	b	Body	Contact	Amphenol Number
1/4" Helical	Solderless	1.97	.74	White Bronze	Gold	<a href="#">S1WNM</a>
1/4" Helical	Solder	1.97	.74	Silver	Gold	<a href="#">S1PNM-S</a>
3/8" Helical	Solderless	2.437	.875	White Bronze	Gold	<a href="#">S2WNM</a>
3/8" Helical	Solder	2.437	.875	Silver	Gold	<a href="#">S2PNM-S</a>
3/8" Helical	Solderless	2.437	.875	Silver	Gold	<a href="#">S2WNM-SO</a>
1/2" Helical	Solderless	2.46	.950	White Bronze	Gold	<a href="#">S4WNM-U</a>
1/2" Helical	Solder	2.46	.950	White Bronze	Gold	<a href="#">S4WNM-SU</a>
1/2" Helical	Solder	2.46	.950	Unplated	Silver	<a href="#">S4NM-S</a>
1/2" Annular	Solderless	2.81	1.025	Silver	Gold	<a href="#">A4PNM</a>
1/2" Annular	Solder	2.81	1.03	Silver	Gold	<a href="#">A4PNM-S</a>
1/2" Annular	Solder	2.81	1.03	Unplated	Silver	<a href="#">A4NM-S</a>
1/2" Annular	Solderless	2.81	1.025	Unplated	Silver	<a href="#">A4NM</a>
7/8" Annular	Solderless	2.99	1.62	Silver	Silver	<a href="#">A5PNM</a>
7/8" Annular	Solderless	2.99	1.62	Unplated	Silver	<a href="#">A5NM</a>

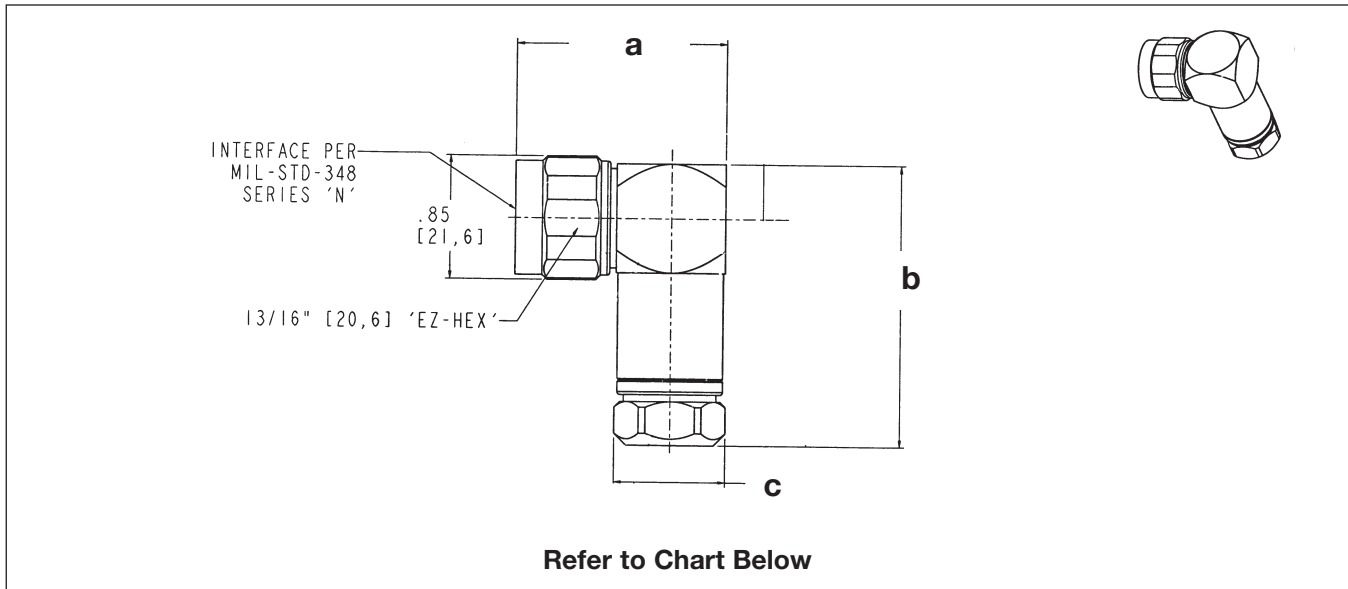

## N PLUG INTERFACE — RIGHT ANGLE

Cable	Inner Attachment	a	b	c	Body	Contact	Amphenol Number
<b>1/4" Helical</b>	Solderless	1.45	1.94	.76	White Bronze	Gold	<b>S1PNR</b>
<b>3/8" Helical</b>	Solderless	1.679	2.30	.875	White Bronze	Gold	<b>S2PNR-SO</b>
<b>1/2" Helical</b>	Solder	1.74	1.91	.94	White Bronze	Gold	<b>S4PNR-S</b>
<b>1/2" Helical</b>	Solderless	1.74	2.26	.94	White Bronze	Gold	<b>S4PNR</b>
<b>1/2" Annular</b>	Solderless	1.80	2.53	1.00	White Bronze	Gold	<b>A4PNR</b>

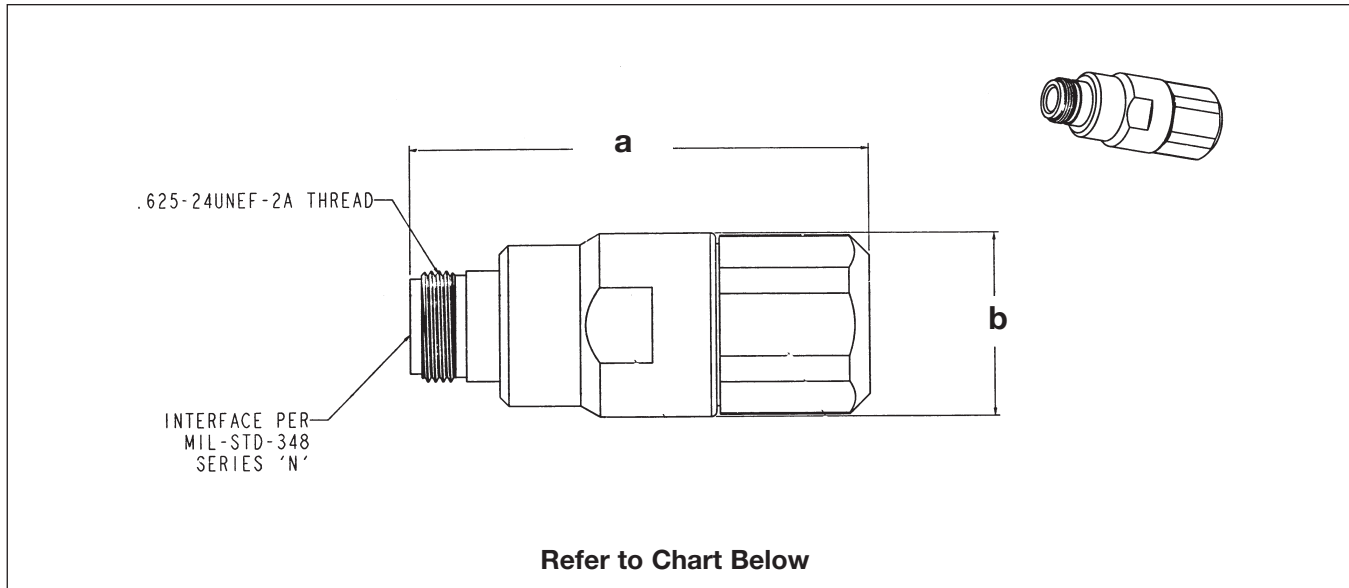

## N JACK INTERFACE — STRAIGHT

Cable	Inner Attachment	a	b	Body	Contact	Amphenol Number
1/4" Helical	Solderless	1.87	.74	White Bronze	Gold	<a href="#">S1WNF</a>
1/2" Helical	Solderless	2.36	.95	White Bronze	Gold	<a href="#">S4WNF-U</a>
1/2" Helical	Solder	2.36	.95	Silver	Gold	<a href="#">S4PNF-S</a>
1/2" Helical	Solder	2.36	.95	Unplated	Silver	<a href="#">S4NF-S</a>
1/2" Annular	Solderless	2.56	1.03	White Bronze	Gold	<a href="#">A4WNF</a>
1/2" Annular	Solder	2.56	1.03	Silver	Gold	<a href="#">A4PNF-S</a>
1/2" Annular	Solder	2.56	1.03	Unplated	Silver	<a href="#">A4NF-S</a>
1/2" Annular	Solderless	2.56	1.03	Unplated	Silver	<a href="#">A4NF</a>
7/8" Annular	Solderless	2.64	1.62	Unplated	Silver	<a href="#">A5NF</a>
7/8" Annular	Solderless	2.64	1.62	White Bronze	Gold	<a href="#">A5WNF</a>
1 1/4" Annular	Solderless	3.81	1.87	White Bronze	Gold	<a href="#">A6WNF</a>
1 1/4" Annular	Solderless	3.81	1.87	Silver	Gold	<a href="#">A6PNF-H</a>
1 1/4" Annular	Solderless	3.81	1.87	Unplated	Silver	<a href="#">A6NF</a>
1 1/4" Annular	Solderless	3.81	1.87	Unplated	Silver	<a href="#">A6NF-H</a>
1 5/8" Annular	Solderless	4.26	2.36	White Bronze	Gold	<a href="#">A7WNF</a>
1 5/8" Annular	Solderless	4.26	2.36	Unplated	Silver	<a href="#">A7NF-1</a>

# Helical N - Corrugated Jack Bulkhead Mount

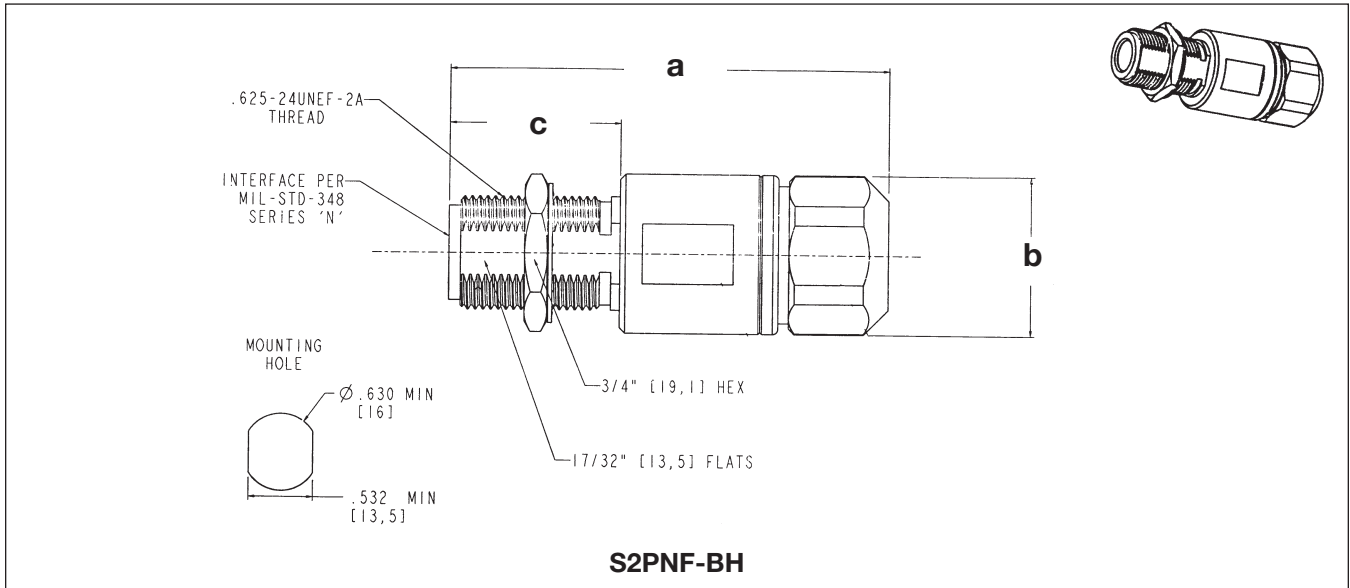

## N JACK BULKHEAD MOUNT

Cable	Inner Attachment	a	b	c	Body	Contact	Amphenol Number
3/8" Helical	Solderless	2.42	.88	.94	Silver	Gold	<b>S2PNF-BH</b>

Type N



## Description

Type F connectors serve a low cost market with prices from \$0.50 to \$0.95. Amphenol provides a high performance alternative. All connectors comply with a 3/8-32 thread specification.

The Type F is similar to the Type G except it is threaded rather than snap-on. Primary applications are for cable television (CATV), set top boxes, and cable modems.

With the deployment of 750 MHz Hybrid Fiber Coax (HFC) networks, it became increasingly obvious that existing low performance F receptacles could not be used in high speed cable modems and customer interface units (CIUs). The industry has challenged connector manufacturers to develop high performance connectors featuring -30 dB return loss at 1 GHz. Additionally, these high performance connectors must still accept .022-.042 in. diameter conductors.

## Features/Benefits

- Patent pending contact design provides a truly cylindrical coaxial contact and provides superior RF performance and excellent insertion/withdrawal characteristics.
- 30 dB return loss to 1 GHz ensures a high performance specification that outperforms competition.
- Multiple PCB mount packages: surface mount, edge mount, right angle and straight, meets many customer applications needs.
- Accommodates .022 - .042 inch center conductor sizes. One connector accommodates a wide range of cable sizes reducing part numbers.



## Applications

- Cable Assemblies
- CATV
- CIMs
- Head End Equipment
- High Speed Cable Modems
- Hybrid Fiber Coax Networks
- Set Top Boxes

## Type F Receptacles

Specifications	246
Receptacles	247
Jacks	248-249

## Type F Adapters

Specifications	250
Adapters	251

## SCTE Type F

Specifications	252
----------------	-----

## SPECIFICATIONS

Impedance:	75 ohms
RF Leakage:	-100 dB min. @ 1 GHz
Temperature Range:	-40°F to +140°F (-40°C to +60°C)

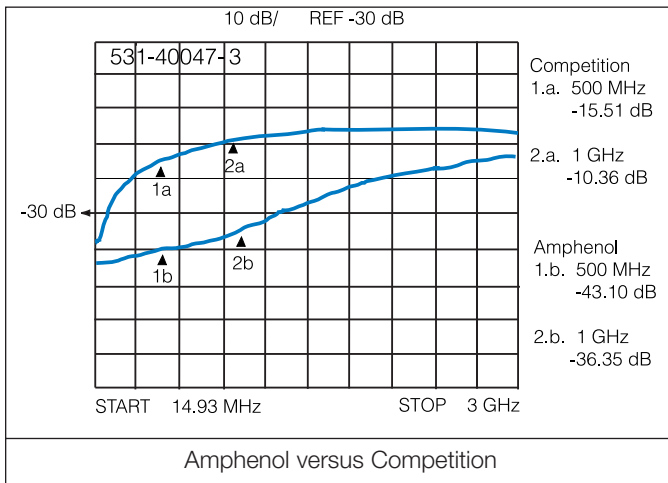

Amphenol Number	Frequency Range	Return Loss
<b>531-40001</b>	0-1 GHz 1-3 GHz	30 dB minimum 15 dB minimum
<b>531-40035-1006</b>	0-1 GHz 1-3 GHz	20 dB minimum 10 dB minimum
<b>531-40039</b>	0-1 GHz 1-3 GHz	30 dB minimum 15 dB minimum
<b>531-40046</b>	0-1 GHz 1-3 GHz	30 dB minimum 15 dB minimum
<b>531-40047-3</b>	0-1 GHz 1-3 GHz	30 dB minimum 15 dB minimum



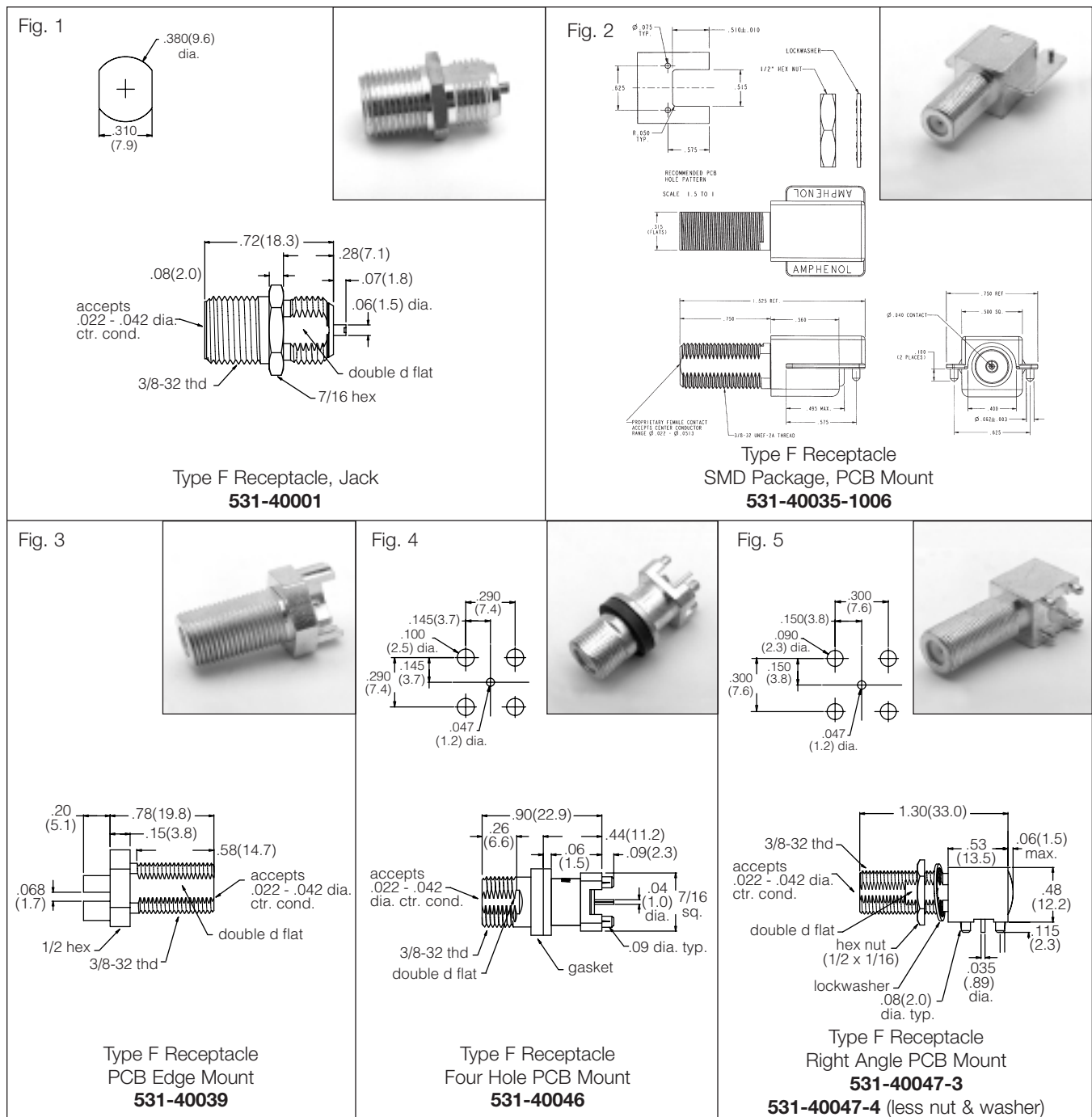

Amphenol Number	Materials			Terminal Type	Fig.
	Body (plating)	Contact (plating)	Insulator		
<b>531-40001</b>	brass (tin lead)	phosphor bronze (tin lead)	PTFE	Flat Tab	1
<b>531-40035-1006</b>	zinc die cast (tin lead)	beryllium copper (tin lead)	PTFE	Flat Tab	2
<b>531-40039</b>	brass (tin lead)	phosphor bronze (tin lead)	PTFE	Round	3
<b>531-40046</b>	zinc die cast (tin lead)	phosphor bronze (tin lead)	Polypropylene	Round	4
<b>531-40047-3</b>	zinc die cast (tin lead)	phosphor bronze (tin lead)	Polypropylene	Round	5
<b>531-40047-4</b>	zinc die cast (tin lead)	phosphor bronze (tin lead)	Polypropylene	Round	5

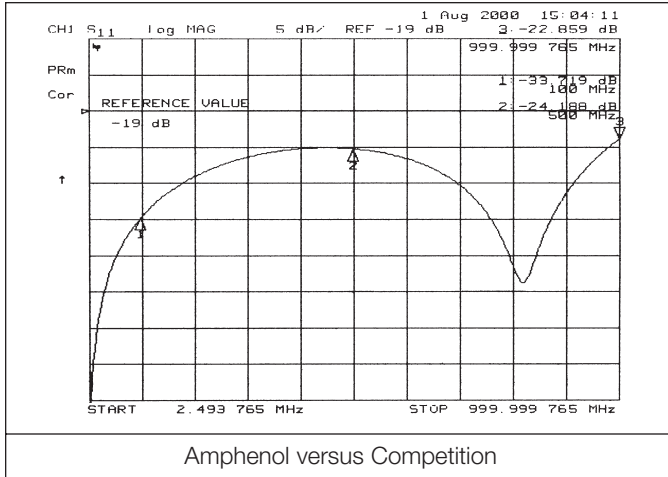

Amphenol Number	Frequency Range	Return Loss
531-40078	0-1.0 GHz	19 dB minimum
531-40078-1	0-1.0 GHz	19 dB minimum
531-40084	0-1.0 GHz	19 dB minimum
531-40084-1	0-1.0 GHz	19 dB minimum

## SPECIFICATIONS

Impedance	75 ohms
Frequency range	0-1 GHz
RF Leakage	-100 dB min. @ 1 GHz
Temperature Range	-40°F to -140°F (-40°C to +60°C)
Coupling Nuts and Bodies	Brass
Contact	Be Cu
Ferrule	Brass
Insulator	Polypropylene

Plating	Body: tin lead plate Contact: bright tin plated Ferrule: tin-lead
Mating	3/8-32 threaded
Cable Attachment	Hex braid-crimp
Cable Retention	20lb. min.

# Type F Bulkhead Jacks

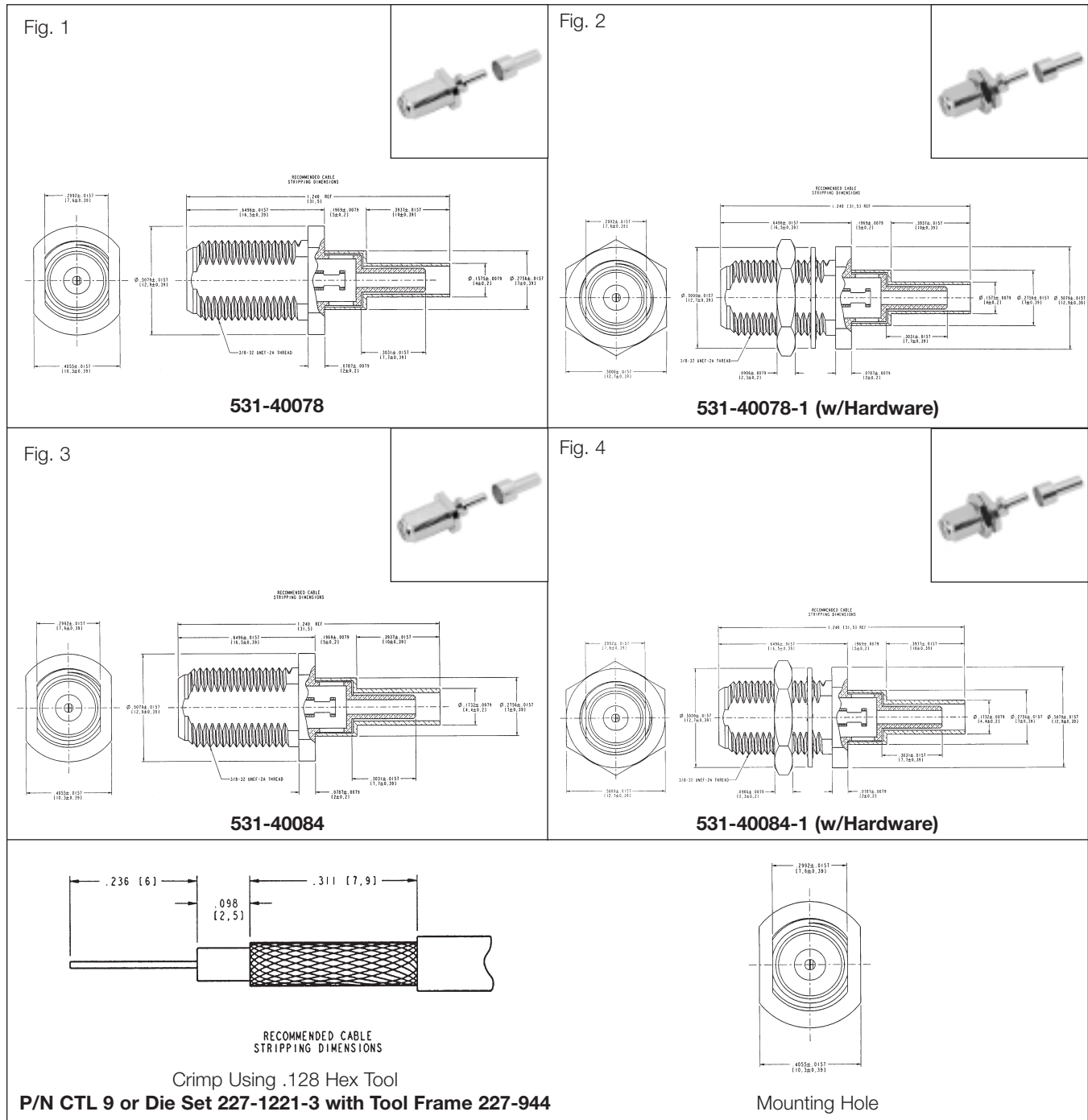

Amphenol Number	Materials			Cable Type	Fig.
	Body (plating)	Contact (plating)	Insulator		
<b>531-40078</b>	Brass (Tin-lead)	BeCu (Bright tin)	Polypolyene	RG179	1
<b>531-40078-1</b>	Brass (Tin-lead)	BeCu (Bright tin)	Polypolyene	RG179	2
<b>531-40084</b>	Brass (Tin-lead)	BeCu (Bright tin)	Polypolyene	RD179	3
<b>531-40084-1</b>	Brass (Tin-lead)	BeCu (Bright tin)	Polypolyene	RD179	4

## Description

Amphenol offers an assortment of Type F and G coaxial adapters designed to meet application specific needs of equipment designers.

With the deployment of 750 MHz Hybrid Fiber Coax (HFC) networks, it became increasingly obvious that existing low performance adapters and receptacles could not be used in the new high performance equipment. A need for high performance connectors featuring -30 dB at 1 GHz and -20 dB at 3 GHz became a reality. Additionally, these high performance connectors must still accept .022-.042 in. diameter conductors.

Working with industry leaders, Amphenol has developed a variety of F and G adapters for use on high performance equipment. These connectors utilize Amphenol's unique patented female contact design featuring a true cylindrical phosphorous bronze coaxial contact. As a result, superior RF performance and excellent insertion/withdrawal characteristics for .022-.042 in. diameter center conductors are achieved.

The F and G adapters are available in multiple styles including straight and right angle PCB mount as well as SMD versions.

All connectors comply with the 3/8-32 UNEF Thread Specification and the MIL-Std. 202 Specification for vibration, shock, thermal shock, moisture resistance and salt spray.

## Features/Benefits

- Patent pending contact design provides a truly cylindrical coaxial contact.
- 30 dB return loss to 3 GHz.
- Accommodate .022-.042 in. center conductor sizes.

## Applications

- High Speed Modems
- CIMs
- Hybrid Fiber Coax Networks
- CATV
- Head End Equipment
- Set Top Boxes

## SPECIFICATIONS

Impedance:	75 ohms
RF Leakage:	-100 dB min. @ 1 GHz
Temperature Range:	-40°F to +140°F (-40°C to +60°C)

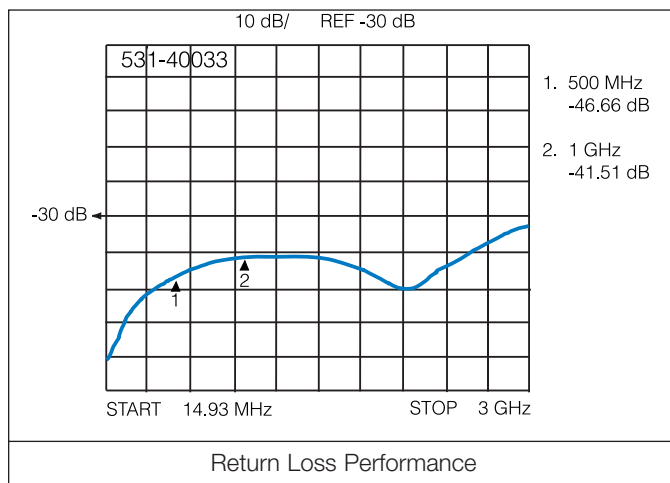

Amphenol Number	Frequency Range	Return Loss
531-40008	0-3 GHz	30 dB minimum
531-40033	0-3 GHz	36 dB minimum
531-40010	0-3 GHz	30 dB minimum
531-40009	0-3 GHz	36 dB minimum

# Type F to Type F In-Series Adapters

<p>Fig. 1</p> <p>Type F to Type F Adapter with Membrane Seal <b>531-40008</b></p>		<p>Fig. 2</p> <p>Type F to Type F Adapter <b>531-40033</b></p>	
<p>Fig. 3</p> <p>Type F Jack to Type F Push-on <b>531-PF67</b></p>		<p>Fig. 4</p> <p>Type F Plug 75Ω Dummy Load <b>531-1504-001</b></p>	
<p>Fig. 5</p> <p>Type F R/A Plug to Jack <b>531-40072</b></p>		<p>Fig. 6</p> <p>Type F Plug to F Plug Adapter <b>531-1503-001</b></p>	

Amphenol Number	Materials			Terminal Type	Fig.
	Body (plating)	Contact (plating)	Insulator		
<b>531-40008</b>	Brass (Tin plate)	phosphor bronze (Astroplate®)	PTFE	N/A	1
<b>531-40033</b>	Brass (Tin lead)	phosphor bronze (tin lead)	PTFE	N/A	2
<b>531-PF67</b>	Brass (Nickel)	Brass (Nickel)	DELTRIN	N/A	3
<b>531-1503-001</b>	Brass (Nickel)	Brass (Nickel)	PTFE	N/A	6
<b>531-40072</b>	Brass (Nickel)	Plug-Brass (Nickel) Jack-Phosphor Bronze	DELTRIN	N/A	5
<b>531-1504-001</b>	Brass (Nickel)	Brass (Nickel)	PTFE	N/A	4

# Type F Connectors

## SCTE Type F Specifications

IPS-SP-400  
Recommended "F" Jack (Port)

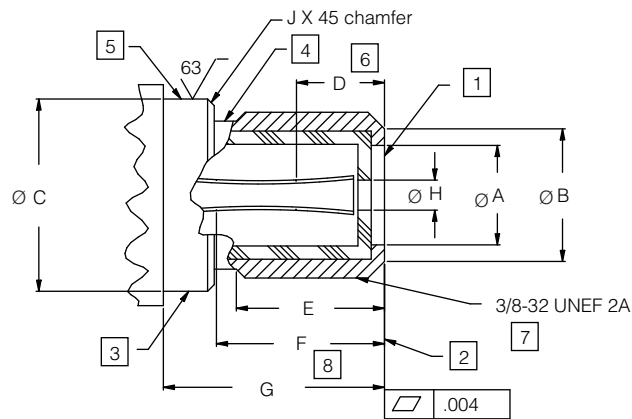

Description	DIM	mm		in		Notes
		min	max	min	max	
Face opening inner diameter	A	4.32	6.10	.170	.240	
Face outer diameter	B	7.11	8.00	.280	.315	
Base outer diameter	C	9.40	11.05	.370	.435	
Center conductor contact to face length	D	—	5.08	—	.200	6
Port threaded length	E	8.26	8.89	.325	.350	
Center contact depth	F	9.65	—	.380	—	8
Sealing surface to face length	G	12.07	13.21	.475	.520	
Center conductor guide inner diameter	H	—	1.73	—	.068	
Chamfer break	J	0.25	0.76	.010	.030	

**NOTES:**

1. Dielectric must not protrude beyond reference plane after installation
2. Reference plane after installation on standard port tightened to 30 inch lbs and removed
3. No casting lines permitted
4. Thread relief not to exceed 1 full thread
5. Finish required for port seal ring
6. Dimension to point of positive contact of terminal
7. ANSI specification B1.1 (major dia 0.368/0.374)
8. Limit of clearance for maximum center conductor
9. Recommended center conductor 0.0513 in maximum

IPS-SP-401  
Recommended "F" Plug

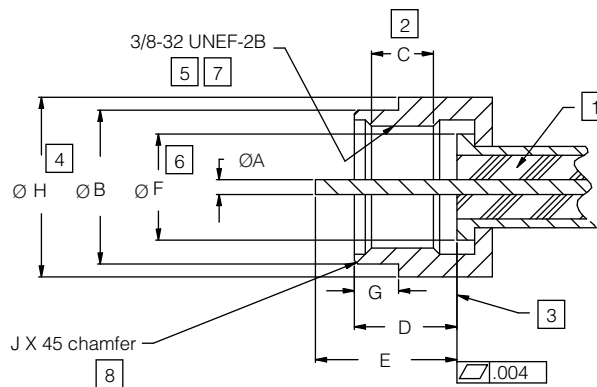

Description	DIM	mm		in		Notes
		min	max	min	max	
Cable center conductor diameter	A	0.56	1.07	.022	.042	
Nut outer diameter	B	10.41	11.05	.410	.435	
Nut threaded length	C	—	—	—	—	2
Mandrel face depth to nut leading edge	D	4.45	6.10	.175	.240	
Center conductor to mandrel face length	E	6.35	9.53	.250	.375	
Mandrel face outer diameter	F	7.11	—	.280	—	6
Nut to sealing sleeve interface length	G	1.78	4.45	.070	.175	
Maximum envelope dimension	H	—	12.90	—	.508	4
Chamfer break	J	—	0.25	—	.010	8

**NOTES:**

1. Dielectric must not protrude beyond reference plane
2. Minimum 4 full threads
3. Reference plane after installation on standard port, tightened to 30 inch pounds and removed
4. Maximum envelope dimension
5. Maximum 1 thread lead-in
6. Minimum diameter of reference plane
7. ANSI specification B1.1
8. Radius optional
9. Connectors must withstand a minimum torque of 60 inch pounds without damage per IPS-TP-400

\*many Amphenol Type F connectors comply to the above specifications.

## Description

The Type G is a snap-on alternative to the Type F with a 15A continuous current rating.

All connectors comply with the 3/8-32 UNEF Thread specification and the Mil-Std 202 specification for vibration, shock, thermal shock, moisture resistance and salt spray.

Since the Type G has an impedance of 75 ohms, it is ideal for CATV applications.

The Type G line consists of Bulkhead Mount Jack Receptacles and PCB Mount Jack Receptacles.



## Features/Benefits

- Push-on blind mate capabilities using BeCu springs provide quick installation; springs allow multiple matings.
- Version available with 15 Amp continuous current capability meets new generation equipment for HFC Networks. (Hybrid Fiber Coax).
- Patent pending contact design provides a truly cylindrical coaxial contact provides superior RF performance and excellent insertion/withdrawal characteristics.
- 30 dB return loss to 1 GHz with 10 Amp current capability. 20 dB return loss with 15 Amp version provides high performance; outperforms competition.

## Application

- CATV
- Head End Equipment
- Components (Amplifiers)
- Hybrid Fiber Coax Networks
- Set Top Boxes

## Type G

Specifications	254
Receptacles	255
Cable Plugs & Jacks	256
Adapters	257

## SPECIFICATIONS

Impedance:	75 ohms
RF Leakage:	-100 dB min. @ 1 GHz
Temperature Range:	-40°F to +140°F (-40°C to +60°C)

Amphenol Number	Frequency Range	Return Loss
<b>531-40087</b>	0-1 GHz 1-2 GHz 2-3 GHz	35 dB minimum 25 dB minimum 15 dB minimum
<b>531-40017</b>	0-1 GHz	12 dB minimum
<b>531-40024</b>	0-1 GHz 1-2 GHz	20 dB minimum 10 dB minimum
<b>531-40051</b>	0-1 GHz 1-2 GHz	20 dB minimum 10 dB minimum

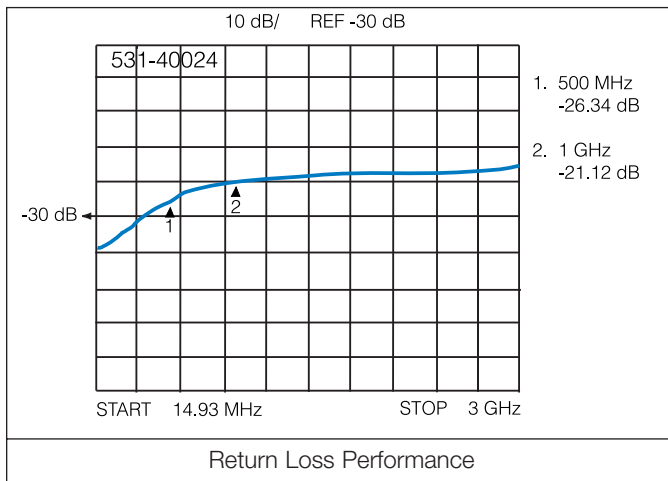



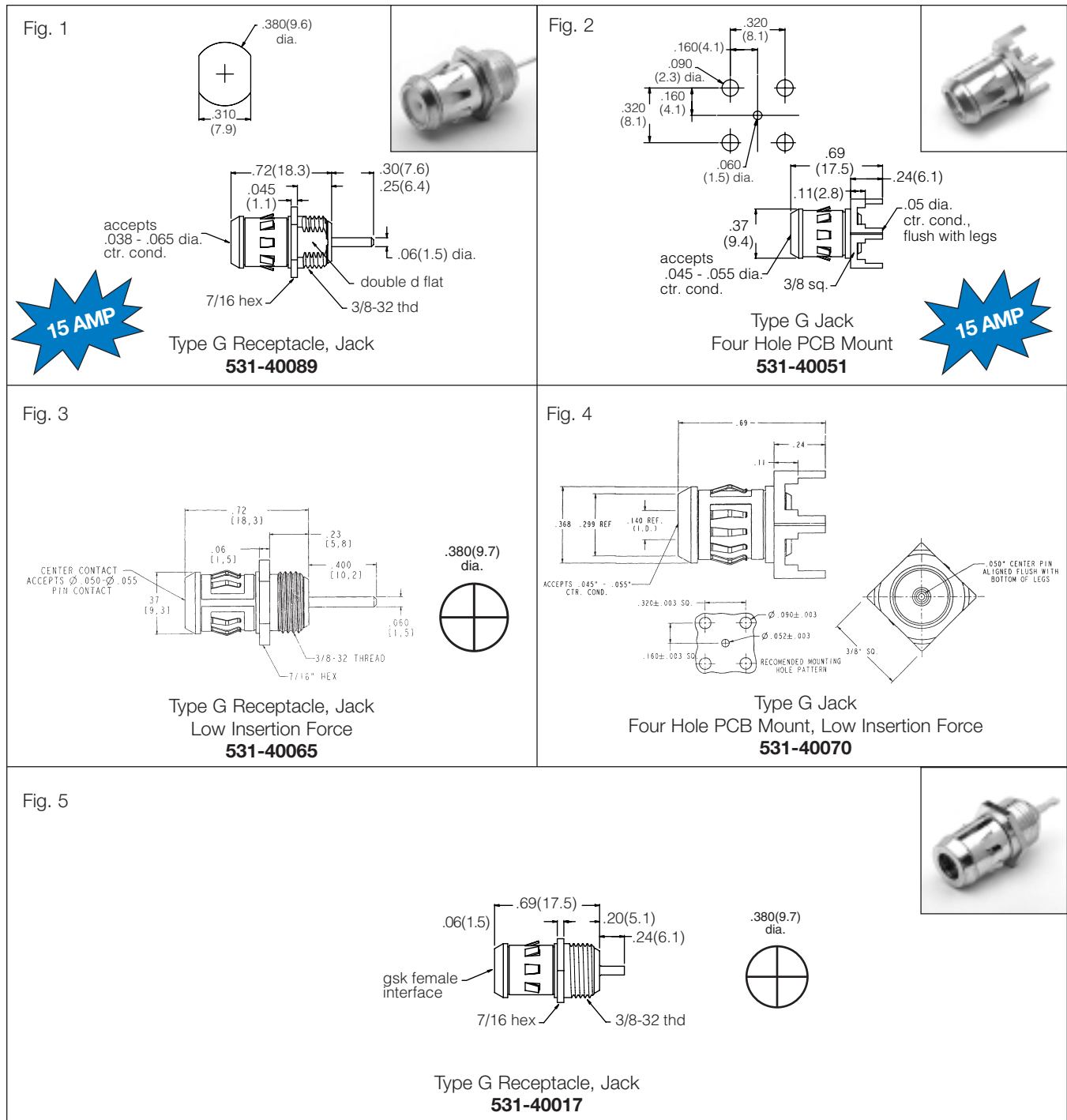

Amphenol Number	Materials			Terminal/Cable Type	Fig.
	Body (plating)	Contact (plating)	Insulator		
531-40089	brass (tin plate)	phosphor bronze (silver)	PTFE	Round	1
531-40051	brass (tin plate)	phosphor bronze (gold over nickel)	PTFE	Round	2
531-40065	brass (tin lead)	phosphor bronze (tin lead)	Polypropylene	Flat Tab	3
531-40070	brass (tin lead)	phosphor bronze (tin lead)	Polypropylene	Flat Tab	4
531-40017	brass (tin lead)	phosphor bronze (tin lead)	Polypropylene	Flat Tab	5

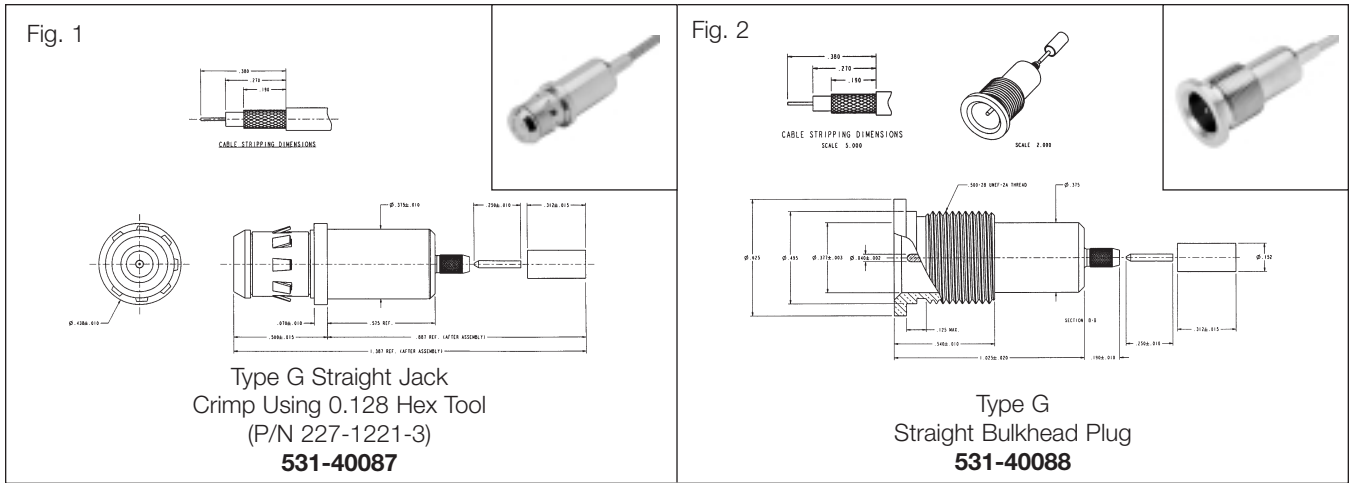

Amphenol Number	Materials			Terminal/Cable Type	Fig.
	Body (plating)	Contact (plating)	Insulator		
<b>531-40087</b>	brass (tin lead)	Be Cu (tin lead)	PTFE	RG179	1
<b>531-40088</b>	brass (tin lead)	Be Cu (tin lead)	PTFE	RG179	2

# Type G Between Series Adapters

Fig. 1

accepts .022 - .026 dia. ctr. cond.

3/8-32 thd

1/2-28 thd

double d flat

gsk male interface

Type F (Jack) to Type G (Plug) Adapter  
**531-40010**

Fig. 2

gsk female interface

7/16 hex

accepts .022 - .042 dia. ctr. cond.

Type G (Jack) to Type F (Jack) Adapter  
**531-40009**

Amphenol Number	Materials			Terminal Type	Fig.
	Body (plating)	Contact (plating)	Insulator		
531-40010	brass (tin lead)	phosphor bronze (tin lead)	PTFE	Round	1
531-40009	brass (tin plate)	phosphor bronze (nickel)	PTFE	N/A	2



## Description

The 7/16 series name derives from the metric dimensions of the connector interface: 7mm OD of inner contact, 16mm ID of outer contact. 7/16 connectors are designed for use in communications systems with power levels of 100 watts per channel.

Long popular in Europe, the 7/16 interface has gained acceptance in the U.S. for its ability to operate at elevated power levels.

There are three families of 7/16 DIN connectors:

- Corrugated Cable Connectors (for both Annular and Superflex cable)
- Standard Cable Connectors
- Custom (Series 7/16)

Deutsh Industries Norm (DIN) are German standards gaining acceptance worldwide.

## Features/Benefits

- Low IMD and low VSWR provides improved system performance.
- Self flaring design ensures ease of installation with standard hand tool.
- Preassembled gasket protects against dust (IP68) and water (IP68), per IEC 169.
- Limited internal junctions reduces sources of IMD.
- Silver plated contacts and silver or white bronze plated bodies deliver a high conductivity and corrosion resistance for a long, trouble free life.
- Easy-Hex coupling nut allows tightening by hand or with a standard wrench for ease of mating.

## Application

- Antennas
- Base Station
- Broadcast
- Cable Assembly
- Components (Control)
- Lightning Protection
- Satcom



## Corrugated Cable

Specifications	261-262
Straight	263
Right Angle	263
Panel Mount	264

## Semi-Rigid & RG Coax Cable

Specifications	265
Straight	266
Right Angle	267
Edge Mount Board	268

## Receptacles

Receptacles	269
-------------	-----

## Adapters

Adapters	271
----------	-----

# Specifications for Corrugated Cable Connectors

## ELECTRICAL

Impedance	50 ohms
Return loss, dB (Frequency GHz) 3 ft Assembly	30 (0.045 - 1.0) 28 (1.000 - 2.0) 21 (2.0 - 3.0)
RF operating voltage max, VRMS	813
Peak power, max, kW	13.2
Average power, max, kW	3.0
Dielectric withstanding voltage	2,300
Shielding effectiveness	125 dB min.
Insertion loss max, dB	0.05 √ (Freq., GHz)
Insulation resistance:	5000 megohms min.
Operating Frequency	5.20 GHz, max.
3rd Order IM product Typical, dBm (dBc)	-120 (-163) (Two +43 dBm carriers IM product @ 910 MHz)

## ENVIRONMENTAL

Temperature range	-40°C to + 150°C
Storage Temp. Range	-70°C to + 100°C
Thermal Shock Test	Pass (IEC 68, part 2-14, test N/A)
Immersion Test	Pass (IEC 529, IP 68)
Corrosion Test	Pass (IEC 68, part 2-1, test Ka)
Vibration Test	Pass (IEC 68, part 2-6)
Mechanical Shock Test	Pass (IEC 68, part 2-27)

## MATERIAL

Body & outer contacts	Brass, ASTM B16 Silver or White Bronze
Inner Contacts	Beryllium Copper ASTM-B196 Silver plate QQ-S-365
Insulator	PTFE resin, ASTM D1457
Gasket	Silicone rubber, ZZ-R- 765
Other metal parts	Brass ASTM B16 Silver or White Bronze
Protective coating on silver plate	Clear Chromate

\* These characteristics are typical and may not apply to all connectors.

## MECHANICAL

Inner Attachment Method	Captivated
Outer Attachment Method	Compression
Connector Durability Test	Pass (DIN 47275 part 2/10.82, sec. 2.10, 500 cycles)
Assembly Torque Body to Clamp nut) lb-ft (n-m)	Positive stop 18/22 (25/30)
Coupling Torque lb-ft (N-m)	15/20 (20/28)
Coupling Nut retention force	100 (445) lbs. (N)

<p><b>S</b></p> <p>┆</p> <p><b>Corrugated Cable</b></p> <p><b>S</b> = Superflex (helical) <b>A</b> = Annular</p>	<p><b>1</b></p> <p>┆</p> <p><b>Cable Diameter</b></p> <p><b>1</b> = 1/4" <b>2</b> = 3/8" <b>4</b> = 1/2" <b>5</b> = 7/8" <b>6</b> = 1 1/4" <b>7</b> = 1 5/8"</p>	<p><b>W</b></p> <p>┆</p> <p><b>Plating</b></p> <p><b>W</b> = White bronze <b>P</b> = Silver plate <b>(none)</b> = Unplated</p>	<p><b>D</b></p> <p>┆</p> <p><b>Interface</b></p> <p><b>D</b> = DIN 7/16</p>	<p><b>M</b></p> <p>┆</p> <p><b>Gender</b></p> <p><b>M</b> = Male (plug) <b>F</b> = Female (jack) <b>R</b> = Right Angle Male (plug)</p>	<p><b>- PM</b></p> <p>┆</p> <p><b>Options</b></p> <p><b>PM</b> = Panel Mount <b>PM-SO</b> = Panel Mount Slotted-Outer <b>U</b> = Universal</p>
--	--	--	---	---	--

# Specifications for Corrugated Cable Connectors

7/16

## PLUG

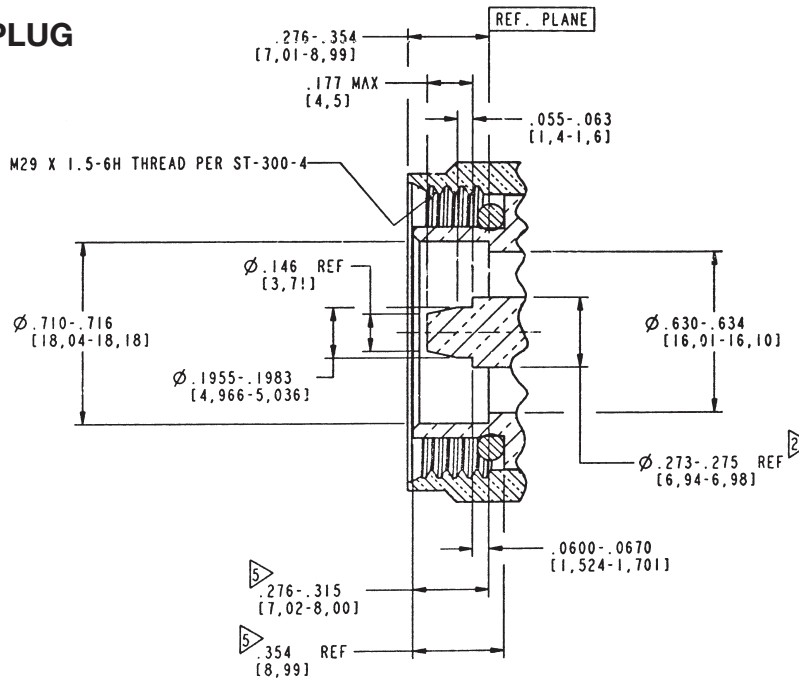

## JACK

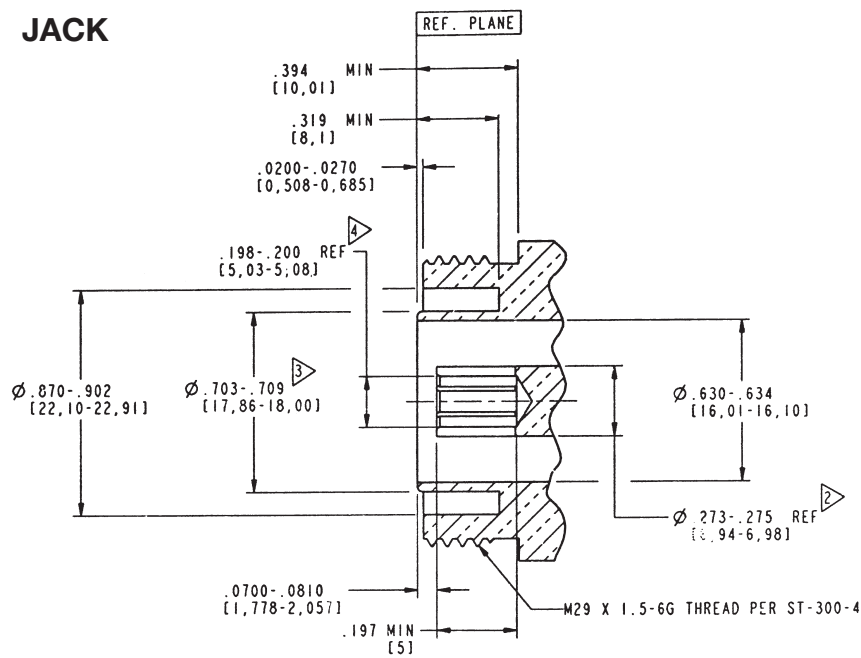

# Corrugated Cable Connectors

RF coaxial connectors are the most important element in your cable system. Corrugated copper coaxial cables have the potential to deliver all the performance your system requires, but they are often limited by the performance of the connectors. Corrugated connectors have been designed from the ground up to deliver optimum performance, while retaining ease of installation.

Intermodulation distortion, a major concern in today's communications systems, is consistently low with these connectors. Typical performance is -125 dBm (-168 dBc). In-house IMD measurement capability gives Amphenol the unique ability to understand the effects of connector design elements on IMD generation and to design the best performing connectors in the industry.

Self-flaring designs are easily attached with standard hand tools in the field, and are highly resistant to pull off and twist off.

All corrugated coaxial connectors are optimally matched to their cables for low VSWR and insertion loss.

### Two-Piece Design

All connectors feature a simple two-piece design for easier attachment, and all connectors for a given size share a common back nut and trimming dimensions.

### Easy-Hex Coupling Nut

Unique coupling nut design allows tightening by hand or with a standard wrench.

### One-Piece Body

Many connectors feature one-piece bodies. The outer conductor contact and connector body are a single piece to minimize IMD generation.

### Plated Surfaces

Center contacts are gold or silver plated. Bodies are white bronze plated for excellent IMD performance, and are corrosion resistant for a long, trouble-free life.

### Pre-assembled O-Rings

O-rings are pre-assembled to the back nuts, eliminating installation problems and lost parts.

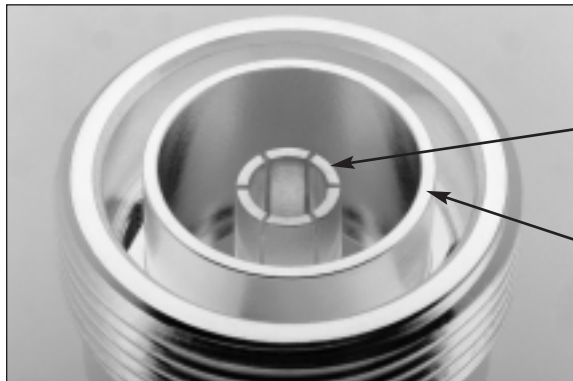
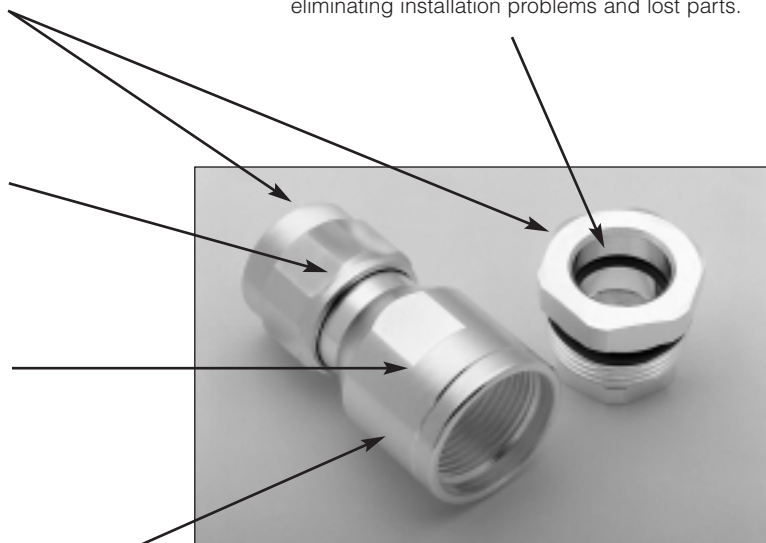

### Captive Center Pins

Captive center pins simplify installation and eliminate performance variations due to soldering errors and incorrect pin depths.

### 360° Contact

Continuous 360° outer conductor contact is proven to minimize IMD generation compared to spring finger contacts.



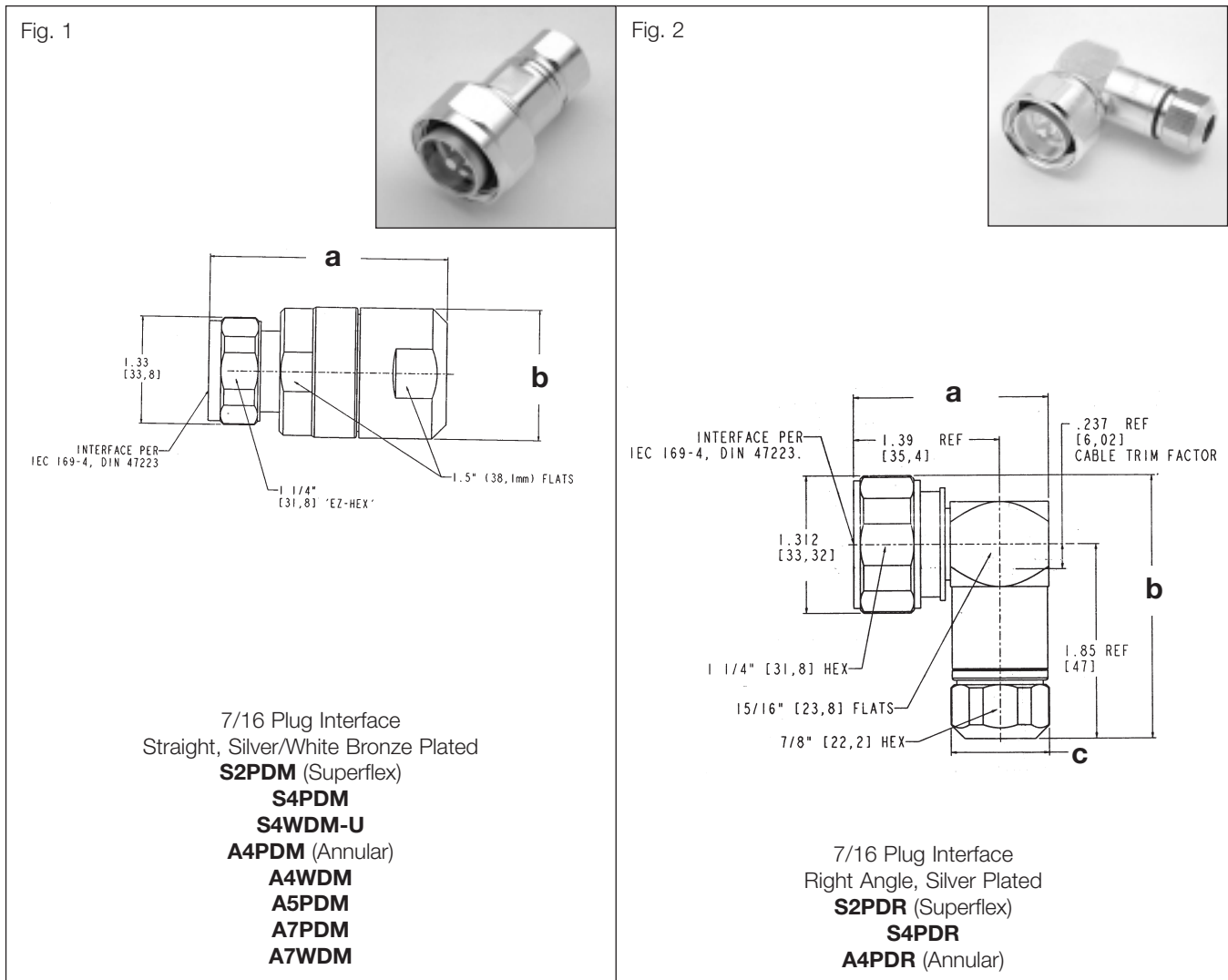

## 7/16 PLUG INTERFACE — STRAIGHT

Cable	Inner Attachment	a	b	c	Body	Contact	Amphenol Number	Fig
3/8" Helical	Solderless	2.20	.875	n/a	Silver	Silver	<b>S2PDM</b>	1
1/2" Helical	Solderless	2.21	.950	n/a	Silver	Silver	<b>S4PDM</b>	1
1/2" Annular	Solderless	2.21	.950	n/a	White Bronze	Silver	<b>S4WDM-U</b>	1
1/2" Annular	Solderless	2.62	1.025	n/a	Silver	Silver	<b>A4PDM</b>	1
1/2" Annular	Solderless	2.62	1.025	n/a	White Bronze	Silver	<b>A4WDM</b>	1
7/8" Annular	Solderless	2.95	1.62	n/a	Silver	Silver	<b>A5PDM</b>	1
1 5/8" Annular	Solderless	4.56	2.36	n/a	Silver	Silver	<b>A7PDM</b>	1
1 5/8" Annular	Solderless	4.56	2.36	n/a	White Bronze	Silver	<b>A7WDM</b>	1

## 7/16 PLUG INTERFACE — RIGHT ANGLE

Cable	Inner Attachment	a	b	c	Body	Contact	Amphenol Number	Fig
3/8" Helical	Solderless	1.81	2.51	.875	Silver	Silver	<b>S2PDR</b>	2
1/2" Helical	Solderless	1.86	2.51	.935	Silver	Silver	<b>S4PDR</b>	2
1/2" Annular	Solderless	1.93	2.76	1.000	Silver	Silver	<b>A4PDR</b>	2

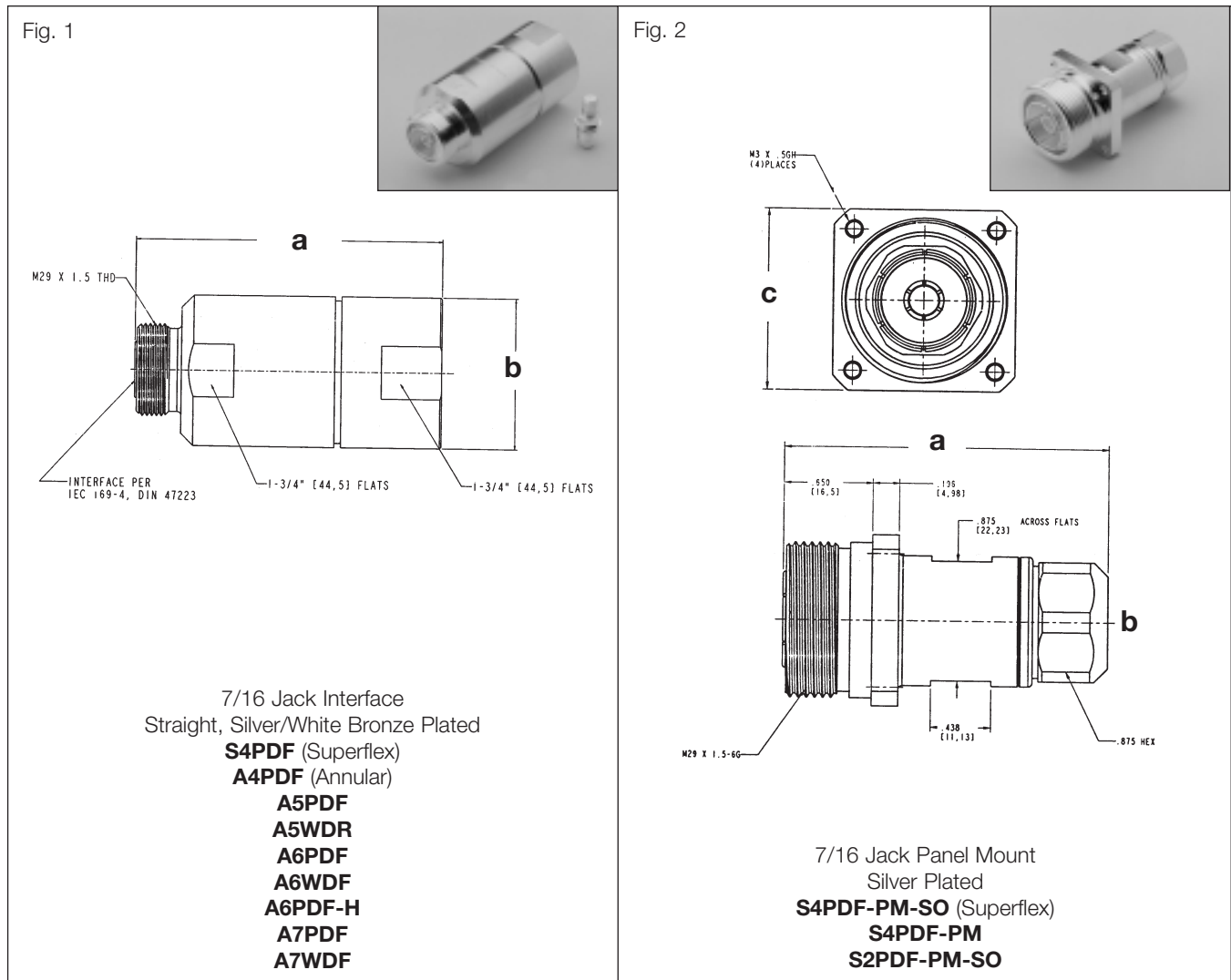

## 7/16 JACK INTERFACE — STRAIGHT

Cable	Inner Attachment	a	b	c	Body	Contact	Amphenol Number	Fig
1/2" Helical	Solderless	2.38	.950	n/a	Silver	Silver	<b>S4PDF</b>	1
1/2" Annular	Solderless	2.62	1.03	n/a	Silver	Silver	<b>A4PDF</b>	1
7/8" Annular	Solderless	2.64	1.62	n/a	Silver	Silver	<b>A5PDF</b>	1
7/8" Annular	Solderless	2.64	1.62	n/a	White Bronze	Silver	<b>A5WDF</b>	1
1 1/4" Annular	Solderless	3.81	1.87	n/a	Silver	Silver	<b>A6PDF</b>	1
1 1/4" Annular	Solderless	3.81	1.87	n/a	White Bronze	Silver	<b>A6WDF</b>	1
1 1/4" Annular	Solderless	3.81	1.87	n/a	Silver	Silver	<b>A6PDF-H</b>	1
1 5/8" Annular	Solderless	4.26	2.36	n/a	Silver	Silver	<b>A7PDF</b>	1
1 5/8" Annular	Solderless	4.26	2.36	n/a	White Bronze	Silver	<b>A7WDF</b>	1

## 7/16 JACK INTERFACE — PANEL MOUNT

Cable	Inner Attachment	a	b	c	Body	Contact	Amphenol Number	Fig
3/8" Helical	Solderless	2.37	.875	1.250	Silver	Silver	<b>S2PDF-PM</b>	2
1/2" Helical	Solderless	2.378	.950	1.250	Silver	Silver	<b>S4PDF-PM</b>	2
1/2" Helical	Solderless	2.378	.950	1.250	Silver	Silver	<b>S4PDF-PM-SO</b>	2

# Specifications - for Semi-Rigid and RG Cable

### ELECTRICAL

Impedance	50 ohms
Frequency range	7.0 GHz max.
Voltage rating	2.7 Kv RMS
Dielectric withstanding voltage	4 Kv RMS
VSWR	1.3 max. 0-7.0 GHz
Insulation resistance:	5,000 megohms min.

### ENVIRONMENTAL

Temperature range	-40°C to + 150°C
Thermal shock	Pass IEC 68, Part 2-14, Test Na
Corrosion	Pass IEC 68, Part 2-1, Test Ka
Vibration	Pass IEC 68, Part 2-6

### MECHANICAL

Mating	M29x1.5 Threaded Coupling
Captivated contact	All configurations except uncaptivated

### MATERIAL

Body & Outer Contact	Brass, Silver or White Bronze Plated
Female contacts	Bergllium Copper, Silver plated
Other metal parts	Brass, Silver or White Bronze plated
Insulators	PTFE
Weatherproof gaskets	Silicone rubber

These characteristics are typical and may not apply to all connectors.

## Catalog Part Number Code

**716**

**Interface**

**716** = 7/16 DIN

**APH-716** = Adapters, 7/16

**XXX**

**Designation**

**#** = Randomly assigned

# 7/16 Plug Semi-Rigid and RG Coax Cables - Straight

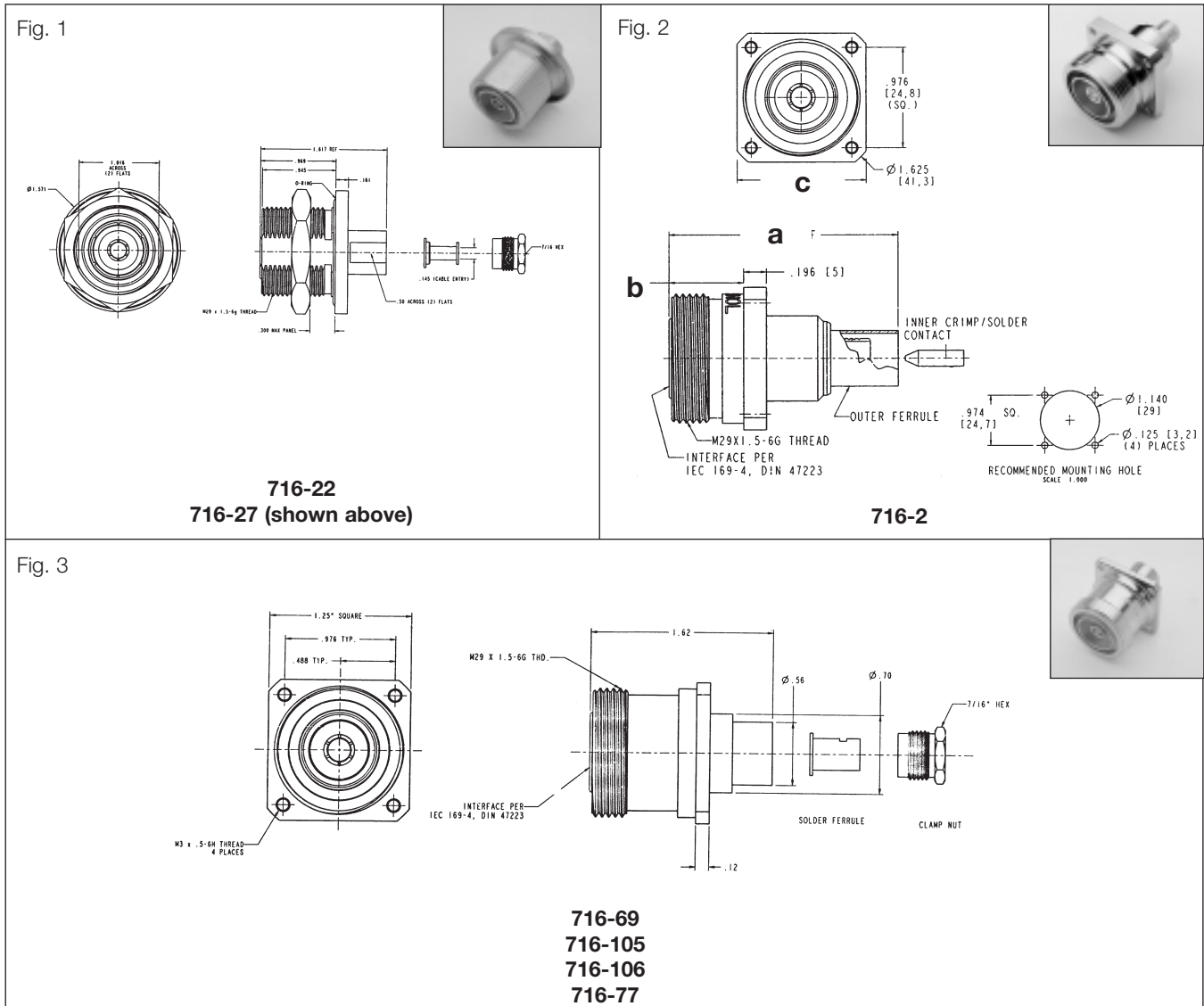

## 7/16 BULKHEAD JACKS -Straight (Solder)

Cable	Inner Attachment	a	b	c	Body	Contact	Amphenol Number	FIG.
.141 Semi-Rigid	Solder	1.617	.969	1.016	W Bronze	Silver	716-27	1
.250 Semi-Rigid	Solder	1.617	.969	1.016	Silver	Silver	716-22	1

## 7/16 PANEL JACKS - Straight (Solder)

Cable	Inner Attachment	a	b	c	Body	Contact	Amphenol Number	FIG.
.250 Semi-Rigid	Solder	1.889	.804	1.250	W Bronze	Silver	716-77	3
.250 Semi-Rigid	Solder	1.62	—	1.250	Silver	Silver	716-69	3
.250 Semi-Rigid	Solder	.753	1.043	1.250	W Bronze	Silver	716-105	3
.141 Semi-Rigid	Solder	.753	1.043	1.250	W Bronze	Silver	716-106	3

## 7/16 PANEL JACKS - Straight (Crimp)

Cable	Inner Attachment	a	b	c	Body	Contact	Amphenol Number	FIG.
RG393	Crimp	1.988	.649	1.250	W Bronze	Silver	716-2	2

# 7/16 Plug RG Coax Cable - Right Angle

7/16

Fig. 1

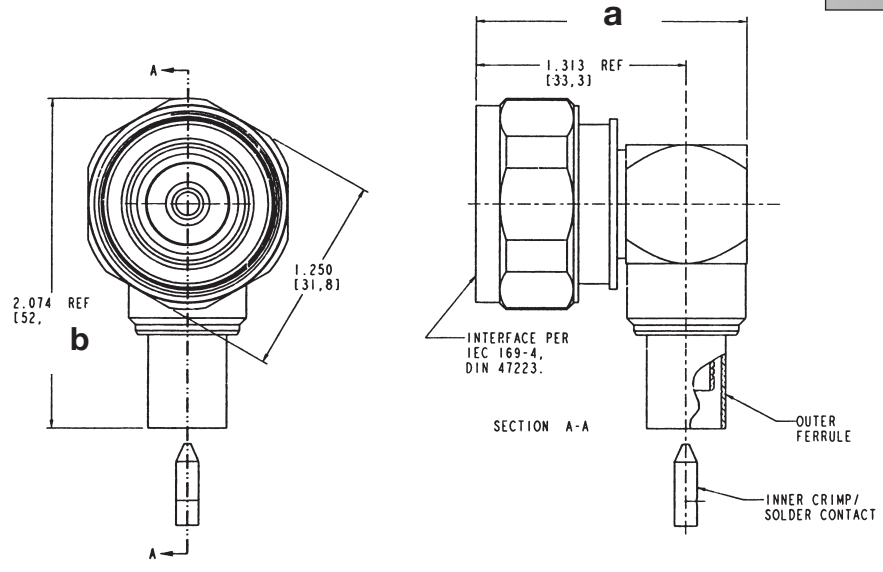

716-3

## 7/16 PLUG INTERFACE -RIGHT ANGLE

Cable	Inner Attachment	a	b	c	Body	Contact	Amphenol Number
RG393	Crimp	1.688	2.074	n/a	W Bronze	Silver	716-3

# 7/16 Semi-Rigid Edge Board Mount

Fig. 1

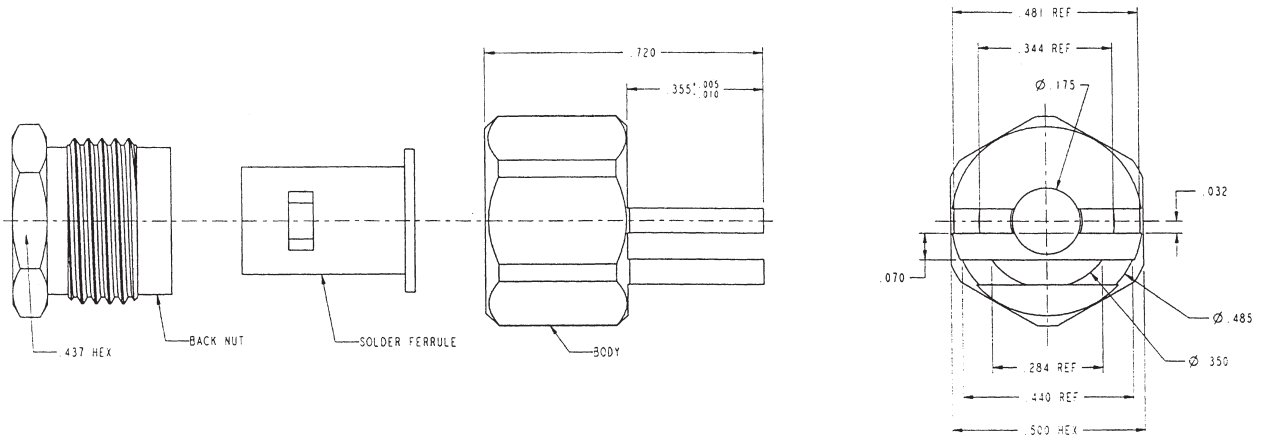

**716-100**  
Edge Board Mount for 0.250 S/R Cable

Fig. 2

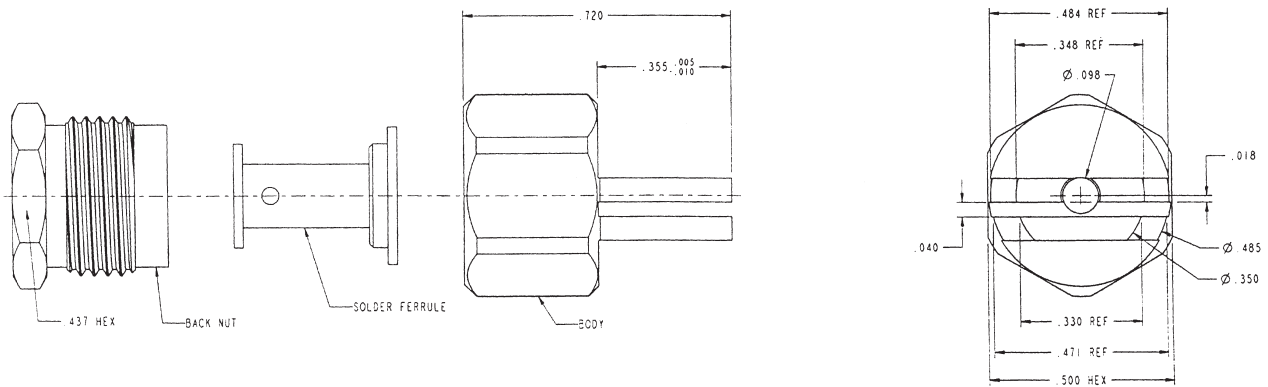

**716-101**  
Edge Board Mount for 0.141 S/R Cable

## 7/16 SEMI-RIGID — EDGE BOARD MOUNT

Cable	Board Thickness	Board Slot Width	Body	Plating	Amphenol Number	FIG.
.250" Semi-Rigid	0.062	0.070	Brass	Silver	<b>716-100</b>	1
.141" Semi-Rigid	0.031	0.040	Brass	Silver	<b>716-101</b>	2

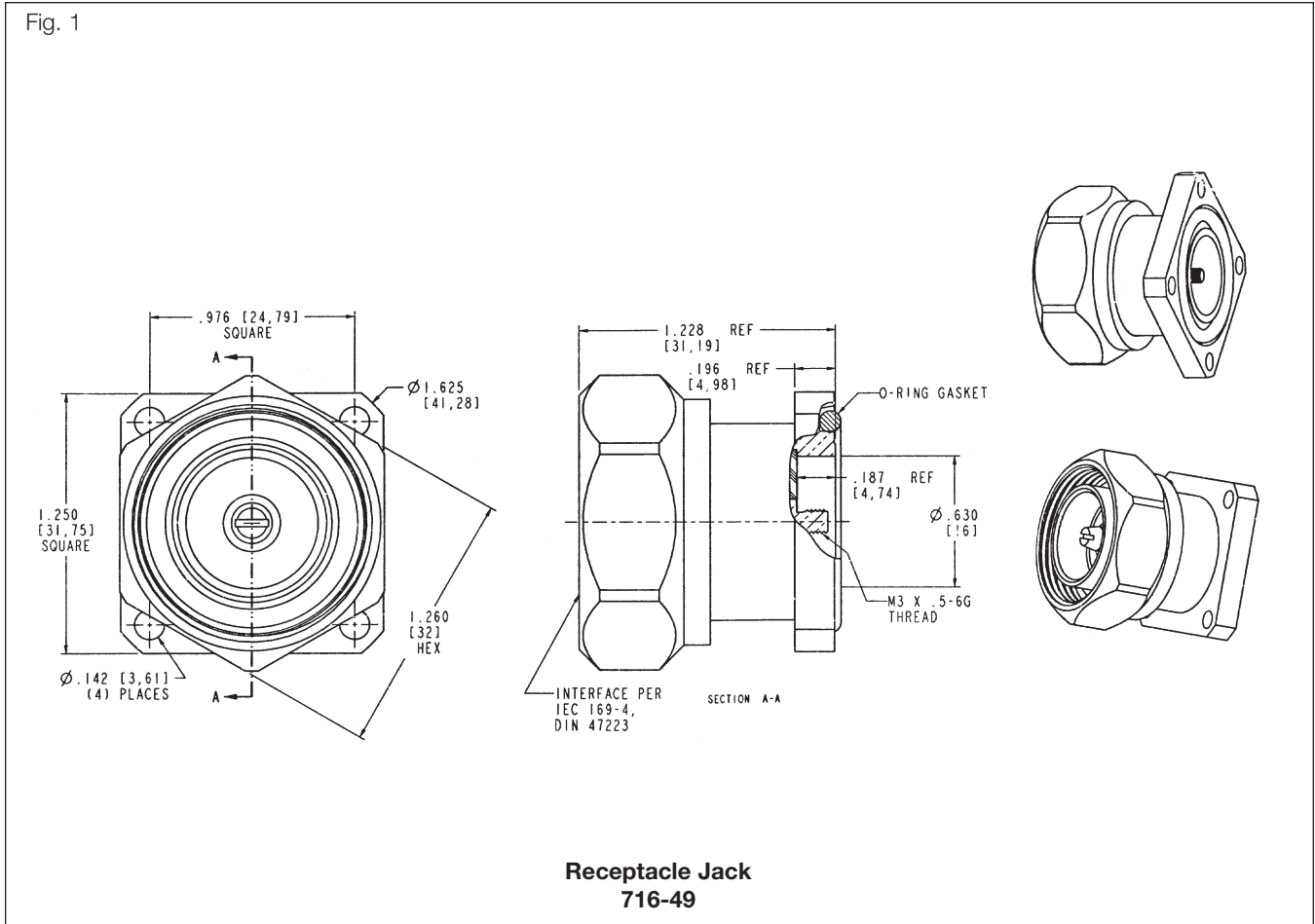

7/16 PLUG — STRAIGHT

Cable	A	B	C	Body	Contact	Amphenol Number	Fig.
M3 Threaded Stud (P)	1.228	1.032	1.25	W Bronze	Silver	716-49	1

# 7/16 Panel Jack Receptacle

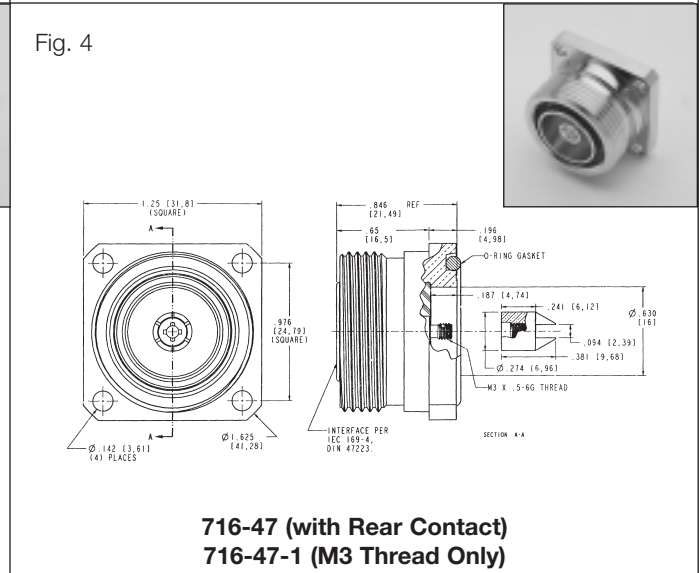
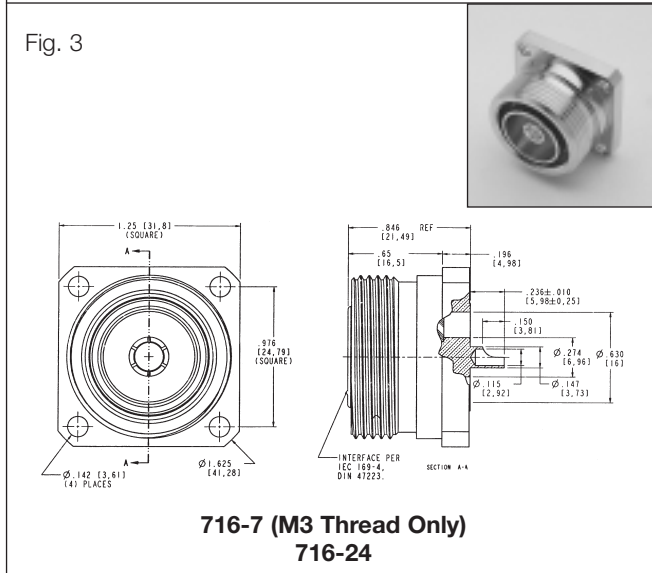
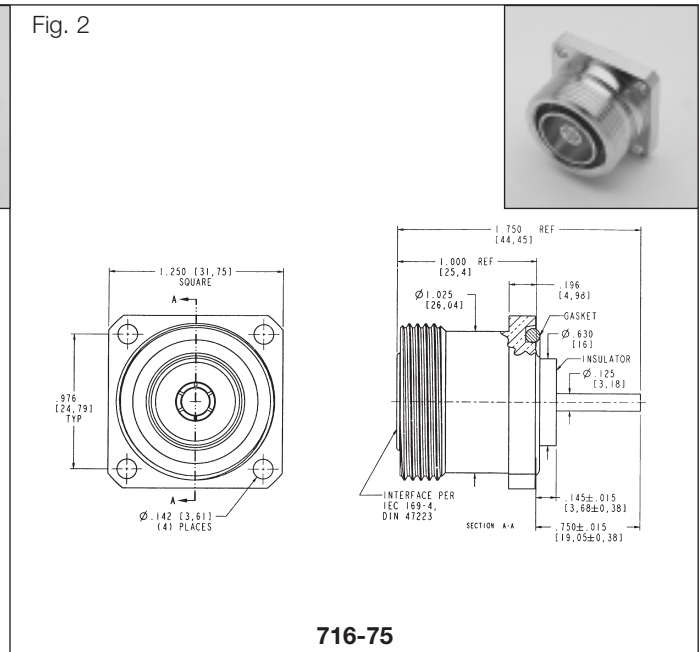
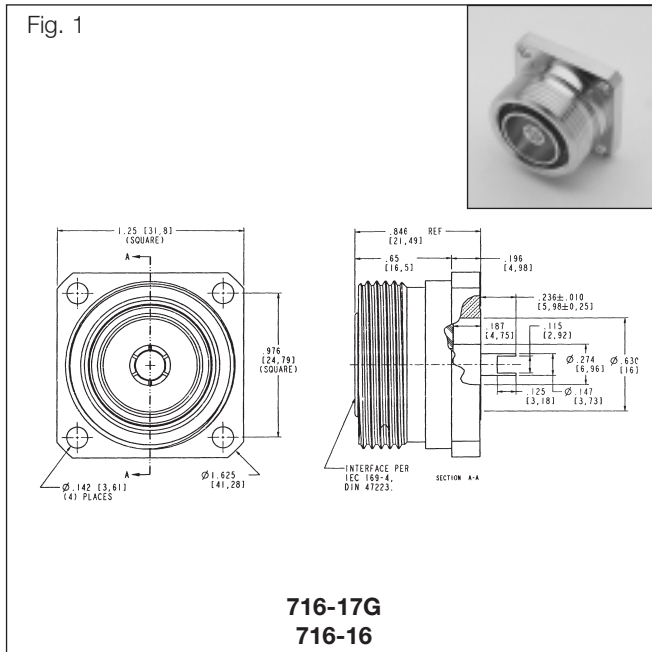

## 7/16 FEMALE JACK — STRAIGHT

Cable	A	B	C	Body	Contact	Amphenol Number	Fig.
.115 Wide Slot	.846	.65	1.25	W Bronze	Silver	<b>716-16</b>	1
.104 Wide Slot	.850	.65	1.25	Silver	Silver	<b>716-17G</b>	1
.115 Solder Cup	.846	.65	1.25	W Bronze	Silver	<b>716-24</b>	3
.094 Wide Slot	.846	.65	1.25	W Bronze	Silver	<b>716-47</b>	4
M3 Threaded Slot	.846	.65	1.25	W Bronze	Silver	<b>716-47-1</b>	4
M3 Threaded Slot	.846	.65	1.25	W Bronze	Silver	<b>716-7</b>	3
Exposed PTFE	1.00	.804	1.25	W Bronze	Gold	<b>716-75</b>	2



Fig. 1

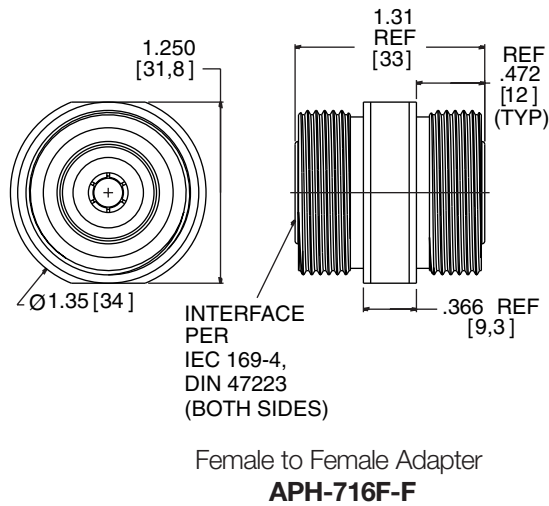
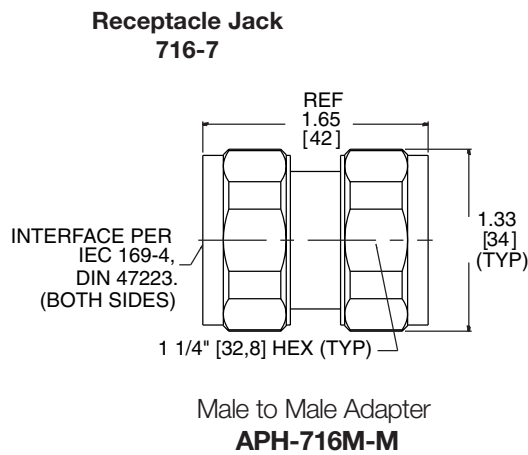

Fig. 2



**7/16 WITHIN SERIES ADAPTERS**

Description	FIG	Amphenol Number
7/16 Female to 7/16 Female Adapter	1	<a href="#">APH-716F-F</a>
7/16 Male to 7/16 Male Adapter	2	<a href="#">APH-716M-M</a>

**Application Note:**

In our adapter terminology, we describe an adapter by referring to it's own construction, not by what the adapter connects to.





Assembly

## UG STANDARD SOLDER TYPE

PLUGS 83-1SP, 83-1SP-1050, 83-1SP-15RFX, 83-822

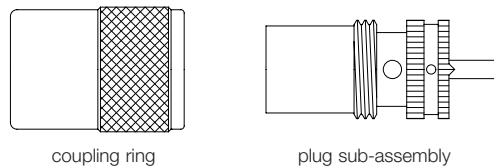

Amphenol Number	Connector Type	Cable RG-/U	Attachment Data		Stripping Dimensions, inches (mm)		
			Outer	Inner	a	b	c
83-1SP-1050	UHF Plug	8, 9, 11, 213, 214, 63, 87A, 225	Solder	Solder	1.25(31.8)	.687(17.4)	.625(15.9)
83-1SP	UHF Plug	8, 9, 11, 213, 214, 63, 87A, 225	Solder	Solder	1.25(31.8)	.687(17.4)	.625(15.9)
83-1SP-15RFX	UHF Plug	8, 9, 11, 213, 214, 63, 87A, 225	Solder	Solder	1.13(28.6)	.689(17.5)	.625(15.9)
83-822	UHF Plug	8, 9, 11, 213, 214, 63, 87A, 225	Solder	Solder	1.25(31.8)	.687(17.4)	.625(15.9)
83-59	UHF Angle Plug	8, 9, 11, 213, 214, 63, 87A, 225	Solder	Solder	.844(21.4)	.391(9.9)	.250(6.4)
83-67	UHF Angle Plug	8, 9, 11, 213, 214, 63, 87A, 225	Solder	Solder	.844(21.4)	.391(9.9)	.250(6.4)

### Step 1

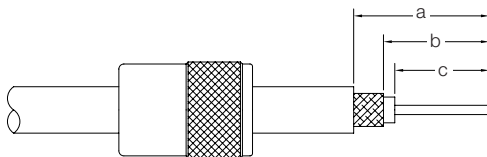

**Step 1** Slide coupling ring onto cable. Cut end of cable even and strip jacket, braid and dielectric to dimensions shown in table. All cuts are to be sharp and square. Do not nick braid, dielectric or center conductor. Tin exposed center conductor and braid, avoiding excessive heat.

### Step 2

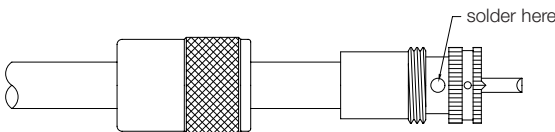

**Step 2** Screw the plug sub-assembly on cable. Solder assembly to braid through solder holes, making a good bond between braid and shell. Solder conductor to contact. Do not use excessive heat.

### Step 3

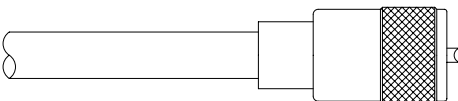

**Step 3** For final assembly on straight plugs, move coupling ring forward and screw in place on plug sub-assembly.

### UG STANDARD SOLDER TYPE WITH REDUCING ADAPTER

FOR PLUGS 83-1SP, 83-1SP-1050, 83-1SP-15RFX, 83-822, USING 83-168 83-168-RFX, OR 83-185, 83-185-RFX REDUCING ADAPTER

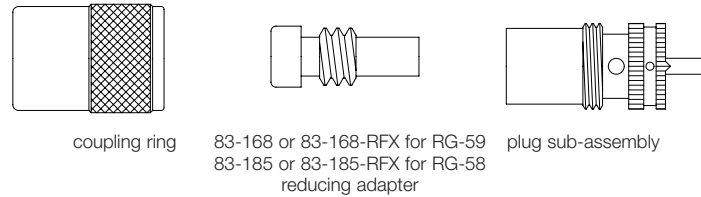

Amphenol Number	Connector Type	Cable RG-/U (using 83-168 or 83-138-RFX)	Cable RG-/U (using 83-185 or 83-185-RFX)	Attachment Data		Using 83-168 or 83-185 Stripping Dims, inches (mm)			Using 83-168-RFX or 83-185-RFX Stripping Dims, inches (mm)		
				Outer	Inner	a	b	c	a	b	c
83-1SP	UHF Plug	59	58	Solder	Solder	.750(19.1)	.375(9.5)	.625(15.9)	.689(17.5)	.375(9.5)	.551(14.0)
83-1SP-1050	UHF Plug	59	58	Solder	Solder	.750(19.1)	.375(9.5)	.625(15.9)	.689(17.5)	.375(9.5)	.551(14.0)
83-1SP-15RFX	UHF Plug	59	58	Solder	Solder	.750(19.1)	.375(9.5)	.625(15.9)	.689(17.5)	.375(9.5)	.551(14.0)
83-750	UHF Plug	59	58	Solder	Solder	.750(19.1)	.375(9.5)	.625(15.9)	.689(17.5)	.375(9.5)	.551(14.0)
83-822	UHF Plug	59	58	Solder	Solder	.750(19.1)	.375(9.5)	.625(15.9)	.689(17.5)	.375(9.5)	.551(14.0)

#### Step 1

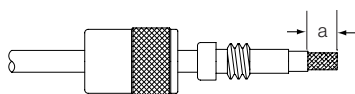

**Step 1** Slide coupling ring and adapter onto cable. Cut end of cable even and strip jacket to dimension shown in table.

#### Step 2

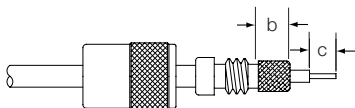

**Step 2** Position adapter flush with end of cable jacket. Fan braid slightly and fold back over body of adapter as shown. Press braid down over body and trim to dimension **b**. Bare conductor to dimension **c** shown in table. Tin exposed center conductor and braid, avoiding excessive heat.

#### Step 3

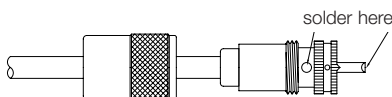

**Step 3** Screw plug sub-assembly onto adapter. Solder braid to shell through solder holes, making a good bond between braid and shell. Solder conductor to contact. Do not use excessive heat.

#### Step 4

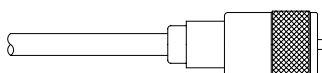

**Step 4** For final assembly, screw coupling ring onto plug sub-assembly.

### C4 — BRAID CRIMP - SOLDER CENTER CONTACT

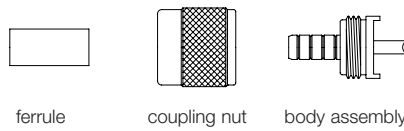

Amphenol Number	Connector Type	Cable RG-/U	Cable Attachment		Hex Crimp Data			Stripping Dims, inches (mm)		
			Outer	Inner	Cavity for Outer Ferrule	Die Set Tool 227-994	CTL Series Tool No.	a	b	c
83-58SP	UHF Plug	58, 141	Crimp	Solder	.213(5.4)	227-1221-11	CTL-1	1.14(29.0)	.780(19.9)	.250(6.4)
83-58SP-1002	UHF Plug	400	Crimp	Solder	.213(5.4)	227-1221-11	CTL-1	1.14(29.0)	.780(19.9)	.250(6.4)
83-59DCP-RFX	UHF Plug	59	Crimp	Solder	.255(6.5)	227-1221-13	CTL-1	1.22(30.9)	.574(22.6)	.543(13.8)
83-58SCP-RFX	UHF Plug	58	Crimp	Solder	.213(5.4)	227-1221-11	CTL-1	1.22(30.9)	.574(22.6)	.543(13.8)
83-59SP	UHF Plug	59	Crimp	Solder	.255(6.5)	227-1221-13	CTL-1	1.22(30.9)	.574(22.6)	.543(13.8)
83-8SP-RFX	UHF Plug	8	Crimp	Solder	.429(10.9)	227-1221-25	CTL-3	1.22(30.9)	.574(22.6)	.543(13.8)

#### Step 1



**Step 1** Cut end of cable even. Strip cable to dimensions shown in table. All cuts are to be sharp and square. Do not nick braid, dielectric or center conductor. Tin center conductor avoiding excessive heat.

#### Step 2

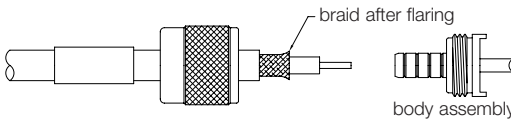

**Step 2** Slide coupling nut and ferrule over cable jacket. Flair braid slightly as shown. Install cable into body assembly, so inner ferrule portion slides under braid, until braid butts shoulder. Slide outer ferrule over braid until it butts shoulder. Crimp ferrule with tool and die set indicated in table.

#### Step 3

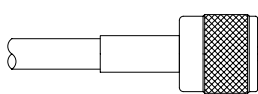

**Step 3** Soft solder center conductor to contact. Avoid heating contact excessively to prevent damaging insulator. Slide/screw coupling nut over body.

### C5 — UHF CRIMP-CRIMP TYPE-C5

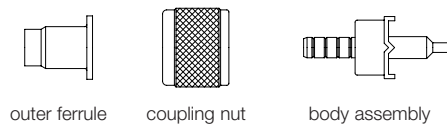

Amphenol Number	Connector Type	Cable RG-/U	Cable Attachment		Hex Crimp Data			a	b	c	CTL Series Tool #	Die Set for Tool 227-944
			Outer	Inner	Cavity for Outer ferrule	Cavity for End of Ferrule	Cavity for Center Contact					
83-58DCP-2	UHF Plug	58	Crimp	Crimp	.260(6.60)	.210(5.33)	.052(1.32) sq.	1.23(31.3)	.791(20.2)	.25(6.35)	—	227-1350
83-58DCP-2RFX	UHF Plug	58	Crimp	Crimp	.255(6.5)	.213(5.4)	.068(1.7)	1.12(28.4)	.685(17.4)	.236(5.99)	CTL-1	227-1221-11,-13

#### Step 1

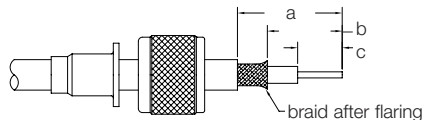

**Step 1** Strip cable to dimensions shown. Slide ferrule and coupling nut over cable jacket and flair braid slightly as shown.

#### Step 2

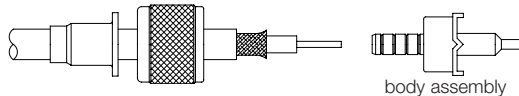

**Step 2** Slide body assembly into place so inner ferrule portion slides under braid. Braid must butt back of body. Slide coupling nut forward. Slide ferrule over braid until it butts against body.

#### Step 3

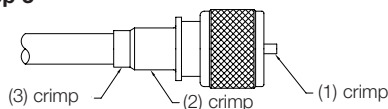

**Step 3** Using tools indicated in table above:  
 (1) crimp center contact  
 (2) crimp outer ferrule to braid  
 (3) crimp outer ferrule to cable jacket

### FCP® TERMINATION FOR PLUGS 83-58FCP, 83-58FCP-RFX on RG-58

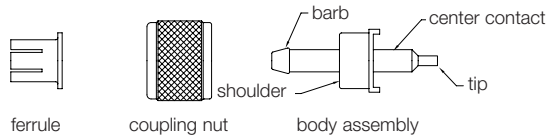

Amphenol Number	Connector Type	Cable RG-/U	Tools	Stripping Dimensions, inches (mm)		
				a	b	c
83-58FCP	FCP Plug	58	Pliers & Fiber Grommet in Bag	1.00(25.4)	.812(20.6)	.500(12.7)
83-58FCP-RFX	FCP Plug	58	Pliers & Fiber Grommet in Bag	.673(17.0)	.547(14.0)	.236(6.0)

**Step 1**

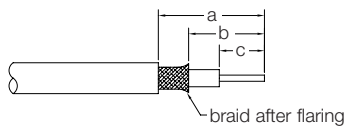

**Step 1** Strip cable to dimensions shown in table.

**Step 2**

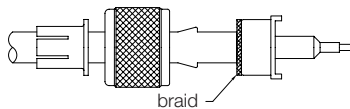

**Step 2** Slide ferrule and coupling nut over cable. Flair braid slightly. Insert body under flared braid until shoulder is against cable jacket.

**Step 3**

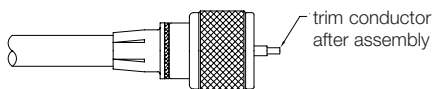

**Step 3** Slide nut onto body. Grasp cable. Push ferrule over barb and up against body. Crimp tip of center contact with pliers, or if you prefer, solder. Then trim center conductor even with end of contact.

## HOODS FOR ADAPTING PANEL RECEPTACLES TO COAXIAL CABLES

83-1H (UG-106/U) for RG-8, 10, 11, 12, 63, 79, 115, 149, 213, 215  
 83-765 (UG-177/U) for RG-58, 141

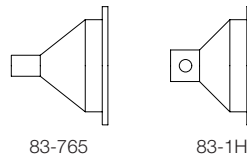

Amphenol Number	Connector Type	Cable RG-/U	Cable Attachment		Stripping Dimensions		
			Outer	Inner	a	b	c
83-1H	Hood	8, 10, 11, 12, 63, 79, 115, 149, 213, 205	Solder	Solder	.625(15.8)	.500(12.7)	.312(7.92)
83-765	Hood	58, 141	Solder	Solder	.750(19.0)	.687(17.4)	.312(7.92)

### Step 1

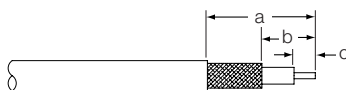

### Step 1

Strip cable to dimensions shown. Do not nick center conductor. Tin exposed braid and center conductor.

### Step 2

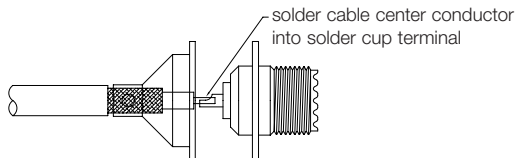

### Step 2

Slide hood over braid. When using double-braided cable, hood goes over inner braid only. Then, in step 3, solder outer braid to outside of hood. Solder Center Conductor into solder cup terminal.

### Step 3

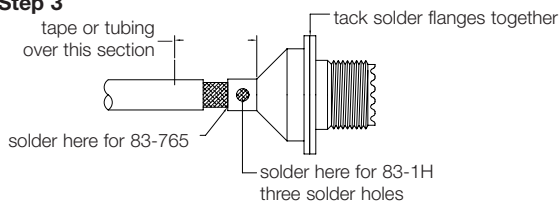

### Step 3

Slide hood flush against receptacle and tack-solder hood flange to receptacle flange. Solder hood to braid as shown. Use tape or tubing over section shown.



## 2-PIECE CRIMP PLUGS

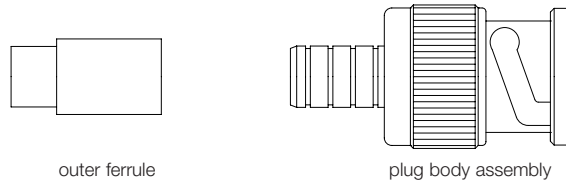

Amphenol Number	Connector Type	Cable RG-/U	Hex Crimp Data			Stripping Dimensions, inches (mm)			
			Cavity for Outer Ferrule	Die Set for Tool 227-944*	CTL Series Tool Number	a	b	c	d
<b>31-5556-RFX</b>	BNC Plug	59, 62	.324(8.2)	227-1221-32	CTL-2	.437(11.1)	.312(7.9)	.248(6.3)	.125(3.2)
<b>31-5557-RFX</b>	BNC Plug	58	.324(8.2)	227-1221-32	CTL-2	.437(11.1)	.312(7.9)	.248(6.3)	.125(3.2)
<b>31-5560-RFX</b>	BNC Plug	Plenum 59, 62	.324(8.2)	227-1221-32	CTL-2	.437(11.1)	.312(7.9)	.248(6.3)	.125(3.2)

### Step 1

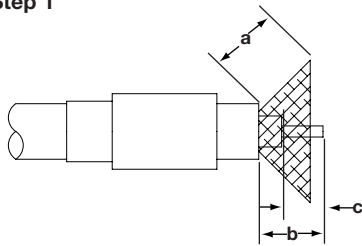

**Step 1** Strip cable jacket, braid, and dielectric to dimensions in table above. All cuts are to be sharp and square. Important: Do not nick braid, dielectric, and center conductor. Slide outer ferrule onto cable as shown.

**Step 2** Flare slightly end of cable braid as shown to facilitate insertion of inner ferrule of connector. Important: Do not comb out braid.

### Step 2

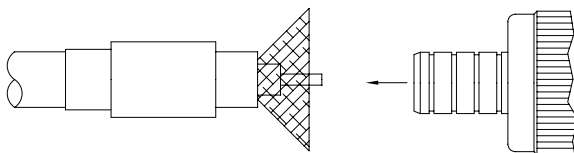

**Step 3** Install cable assembly into body assembly so that inner ferrule portion slides under braid. Slide outer ferrule over braid and up against connector body. Crimp outer ferrule using Die Set Cavity specified in table above.

### Step 3

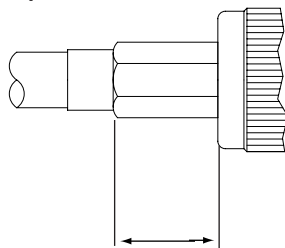

# Assembly Instructions-C8 Type N

## CLAMP TYPES

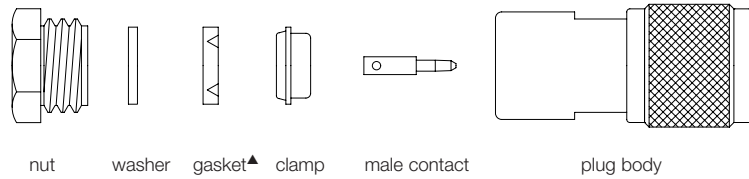

Amphenol Number	Connector Type	Cable RG-/U	Strip Dims., inches (mm)	
			a	c
18750	N Angle Plug	58, 141, 142	.484(12.3)	.234(5.9)
34025	N Plug	58, 141, 142	.390(9.9)	.203(5.2)
34025-RFX	N Plug	58, 141, 142	.354(9.0)	.177(4.5)
35275	N Bulkhead Jack	55, 58, 141, 142, 223	.561(14.3)	.172(4.4)
36250	N Panel Jack	55, 58, 141, 142, 223	.375(9.5)	.188(4.8)
82-63	N Jack	8, 9, 87A, 144, 165, 213, 214, 216, 225	.281(7.1)	.156(4.0)
82-67	N Bulkhead Jack	8, 9, 87A, 144, 165, 213, 214, 216, 225	.281 (7.1)	.156(4.0)
82-202	N Plug	8, 9, 144, 165, 213, 214, 216, 225	.359(9.1)	.234(6.0)
82-202-1006	N Plug	Belden 9913	.359(9.1)	.234(6.0)
82-202-RFX	N Plug	8, 213, 214	.315(8.0)	.177(4.5)
82-209-1006	N Jack	Belden 9913, Times AA-6146, 8 group	.281(7.1)	.156(4.0)
82-312	N Plug	8, 9, 144, 165, 213	.359(9.1)	.234(5.9)
82-3202	N Plug	8, 9, 144, 165, 213	.270(6.9)	.150(3.8)

▲ Not supplied with part number 36250

### Step 1

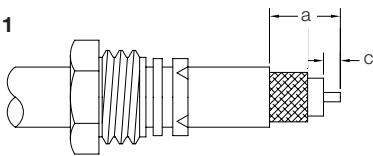

**Step 1** Place nut, washer and gasket (with "V" groove toward open end of cable) over cable, and cut off jacket to dim. **a**.

### Step 2

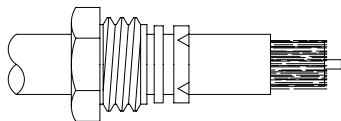

**Step 2** Comb out braid and fold out. Bare center conductor to dim. **c** as shown.

### Step 3

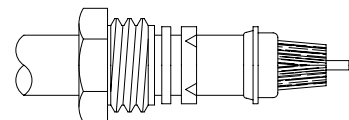

**Step 3** Pull braid wires forward and taper toward center conductor. Place clamp over braid and push back against cable jacket.

### Step 4

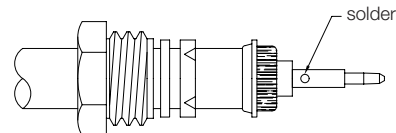

**Step 4** Fold back braid wires as shown, trim braid to proper length and form over clamp as shown. Tin center conductor and solder on contact.

### Step 5

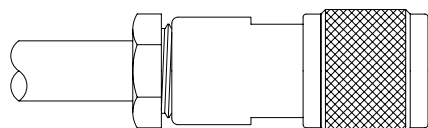

**Step 5** Insert cable and parts into connector body. Make sure sharp edge of clamp seats properly in gasket. Tighten nut.

## RIGHT ANGLE JACKS FOR SEMI-RIGID CABLE

Amphenol Number	A
82-6096-RFX	.138 (3.5)
82-6097-RFX	.138 (3.5)
82-6162	.138 (3.5)
82-6098-RFX	.138 (3.5)
82-6099-RFX	.138 (3.5)
82-6163-RFX	.138 (3.5)
82-5955-RFX	.098 (2.5)
82-5956-RFX	.138 (3.5)
82-6124	.157 (4.0)

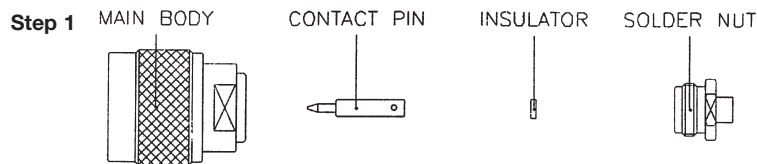

**Step 1** All parts of the connector are shown.



**Step 2** Strip the inner conductor, dielectric, and jacket as per "RECOMMENDED CABLE STRIPPING DIM'S" in catalog.

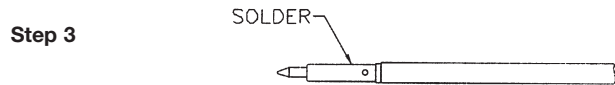

**Step 3** Slide the INSULATOR onto inner conductor against the jacket. Then insert inner conductor into the CONTACT PIN and solder it as shown.

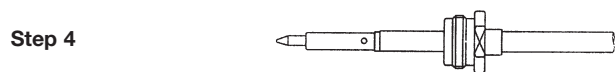

**Step 4** Slide the SOLDER NUT onto cable.

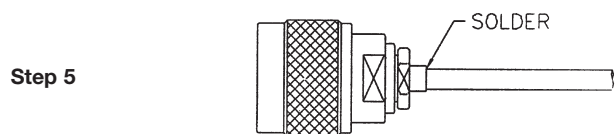

**Step 5** Insert cable and parts into the MAIN BODY, then screw the SOLDER NUT until it is tight and solder it as shown.

## Assembly Instructions Insulated Twinax Plug

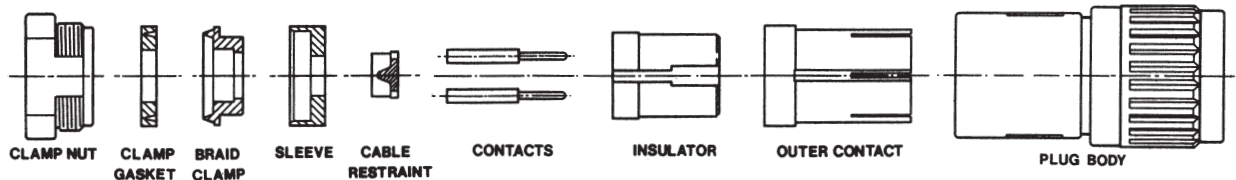

**82-GB635-CR**

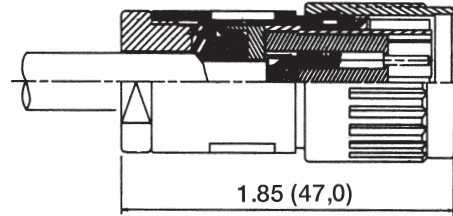
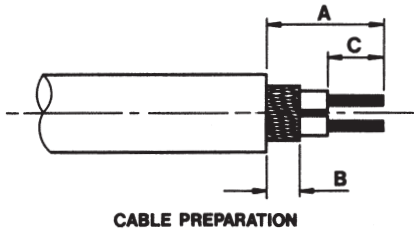

Dim	w/ Cable Restraint	w/o Cable Restraint
A	.550 (13,97)	.550 (13,97)
B	.190 (4,83)	.190 (4,83)
C	.240 (6,10)	.170 (4,32)

**Step 1** Remove clamp nut, braid clamp, sleeve and cable restraint if supplied.

**Step 2** Prepare cable, see dimensions.

**Step 3** Solder contacts.

**Step 4** Assemble as shown.

### CRIMP-CRIMP TYPES



outer ferrule

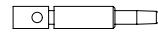

contact

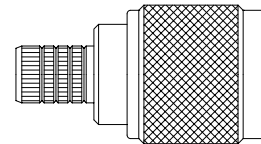

body assembly

Amphenol Number	Connector Type	Cable RG-/U	Strip Dimensions, inches (mm)			Hex Crimp Data			
			a	b	c	Cavity for Contact	Cavity for Outer Ferrule	Die Set for Tool 227-944‡	CTL Series Tool No.
82-332	N Plug	9, 214	.531(13.5)	.234(6.0)	.140(3.5)	.100(2.5)	.429(10.9)	227-1221-25	CTL-3
82-340	N Plug	8, 213	.531(13.5)	.234(6.0)	.141(3.6)	.100(2.5)	.429(10.9)	227-1221-25	CTL-3
82-340-1052	N Plug	B9913, 9914	.539(13.7)	.250(6.4)	.158(4.0)	.116(2.9)	.429(10.9)	227-1221-63	CTL-11
82-340-1054	N Plug	LMR 400	.539(13.7)	.250(6.4)	.157(4.0)	.116(2.9)	.429(10.9)	227-1221-63	CTL-11
82-4425	N Plug	9, 214, 225, 393	.687(17.4)	.281(7.1)	.187(4.7)	.100(2.5)	.429(10.9)	227-1221-25	CTL-3
82-4425-1003	N Plug	9, 214, 225, 393	.687(17.4)	.281(7.1)	.187(4.7)	.100(2.5)	.429(10.9)	227-1221-25	CTL-3
82-4426	N Plug	8, 213	.687(17.4)	.281(7.1)	.187(4.7)	.100(2.5)	.429(10.9)	227-1221-25	CTL-3
82-4426-11RFX	N Plug	8, 213, 214 Eth.Cables	.630(16.0)	.303(7.7)	.157(4.0)	.100(2.5)	.429(10.9)	227-1221-25	CTL-3
82-4426-1001	N Plug	Ethernet Cables	.687(17.4)	.281(7.1)	.187(4.7)	.100(2.5)	.429(10.9)	227-1221-25	CTL-3
82-4426-1002	N Plug	Ethernet Cables	.687(17.4)	.281(7.1)	.187(4.7)	.100(2.5)	.429(10.9)	227-1221-25	CTL-3
82-4427	N Plug	142, 400	.687(17.4)	.281(7.1)	.187(4.7)	.100(2.5)	.213(5.4)	227-1221-57	CTL-3
82-4427-1006	N Plug	142, 142B, 400	.600(15.2)	.275(7.0)	.140(3.5)	.100(2.5)	.213(5.4)	227-1221-57	CTL-3
82-4440	N Angle Plug	214, 225, 393	.687(17.4)	.281(7.1)	.187(4.7)	.100(2.5)	.429(10.9)	227-1221-25	CTL-3
82-4440-1001	N Angle Plug	9, 214, 225, 393	.687(17.4)	.281(7.1)	.187(4.7)	.100(2.5)	.429(10.9)	227-1221-25	CTL-3
82-5370	N Plug	55, 142, 223	.600(15.2)	.275(7.0)	.140(3.5)	.100(2.5)	.213(5.4)	227-1221-57	CTL-3
82-5372	N Panel Jack	55, 141, 142	.600(15.2)	.275(7.0)	.140(3.5)	.100(2.5)	.213(5.4)	227-1221-57	CTL-3
82-5373	N Bulk. Jack	55, 142, 223	.640(16.3)	.315(8.0)	.180(4.6)	.100(2.5)	.213(5.4)	227-1221-57	CTL-3
82-5374	N Angle Plug	55, 142, 223	.687(17.4)	.281(7.1)	.187(4.7)	.100(2.5)	.213(5.4)	227-1221-57	CTL-3
82-5375	N Plug	58, 141	.531(13.5)	.233(5.9)	.140(3.5)	.100(2.5)	.213(5.4)	227-1221-57	CTL-3
82-5375-RFX	N Plug	58, 141	.630(16.0)	.303(7.7)	.157(4.0)	.100(2.5)	.213(5.4)	227-1221-57	CTL-3
82-5378	N Bulk. Jack	58, 141	.640(16.3)	.273(6.8)	.180(4.6)	.100(2.5)	.213(5.4)	227-1221-57	CTL-3
82-5933	N Bulk. Jack	316	.502(12.7)	.102(2.6)	.062(1.6)	Solder	.178(4.5)	227-1221-09	CTL-2
82-5988-1000	N Angle Plug	214, 393	.827(21.0)	.492(12.5)	.157(4.0)	Solder	.429(10.9)	227-1221-6001	CTL-3
82-5988-1004	N Angle Plug	214, 393	.827(21.0)	.492(12.5)	.157(4.0)	Solder	.429(10.9)	227-1221-6001	CTL-3
82-5993	N Plug	LMR 600	.844(21.4)	.344(8.7)	.250(6.4)	.176(4.5)	.612(15.5)	227-1221-6001	—
82-5994	N Bulk. Jack	LMR 600	.844(21.4)	.344(8.7)	.250(6.4)	.176(4.5)	.612(15.5)	227-1221-6001	—
82-5995	N Angle Plug	LMR 600	1.062(27.0)	.562(14.3)	.312(7.9)	Solder	.612(15.5)	227-1221-6001	—
82-6010	N Plug	LMR 240	.610(15.5)	.200(5.1)	.200(5.1)	Press-Fit	.255(6.5)	227-1221-59, 13	CTL-1.5,8
82-6106	N Plug	LMR 240	.687(17.4)	.312(7.9)	.187(4.7)	.100(2.5)	.255(6.5)	227-1221-59	CTL-5
82-5988-1000	N Angle Plug	LMR 240	.827(21.0)	.492(12.5)	.157(4.0)	.100(2.5)	.255(6.5)	227-1221-59	CTL-5
82-5988-1004	N Angle Plug	LMR 240	.827(21.0)	.492(12.5)	.157(4.0)	.100(2.5)	.255(6.5)	227-1221-59	CTL-5

#### Step 1

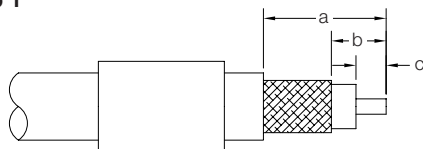

#### Step 1

Strip cable jacket, braid, and dielectric to dimensions shown. All cuts are to be sharp and square. **Important:** Do not nick braid, dielectric, and center conductor. Tinning of center conductor is not necessary if contact is to be crimped. For solder method, tin center conductor avoiding excessive heat.

#### Step 2

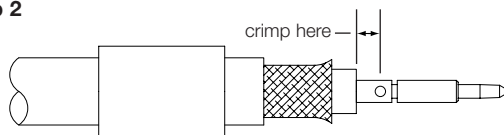

#### Step 2

Slide outer ferrule onto cable as shown. Flare slightly end of cable braid as shown to facilitate insertion of inner ferrule. **Important:** Do not comb out braid. Place contact on cable center conductor so it butts against cable dielectric. Center conductor should be visible through inspection hole in contact. Crimp or solder contact in place as follows:

**Crimp Method:** Use Die Set Cavity for contact indicated in table above. **Solder Method:** Soft solder contact to cable center conductor. Do not get any solder on outside surface of contact. Avoid excessive heat to prevent swelling of dielectric.

#### Step 3

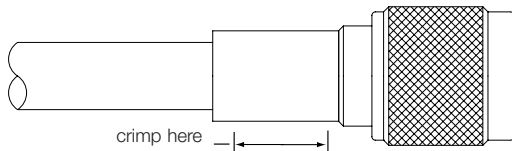

#### Step 3

Install cable assembly into body assembly so inner ferrule portion slides under braid. Push cable assembly forward until contact snaps into place in insulator. Slide outer ferrule over braid and up against connector body. Crimp outer ferrule using Die Set Cavity specified in table above.

# Assembly Instructions-C12

## Triax BNC, 180° Polarity

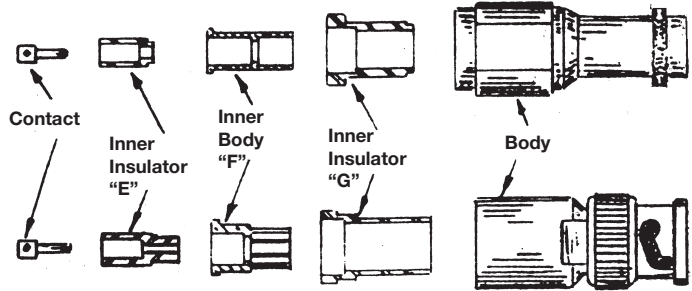
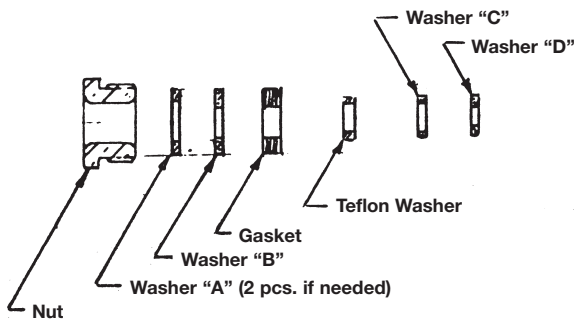

31-4774-3

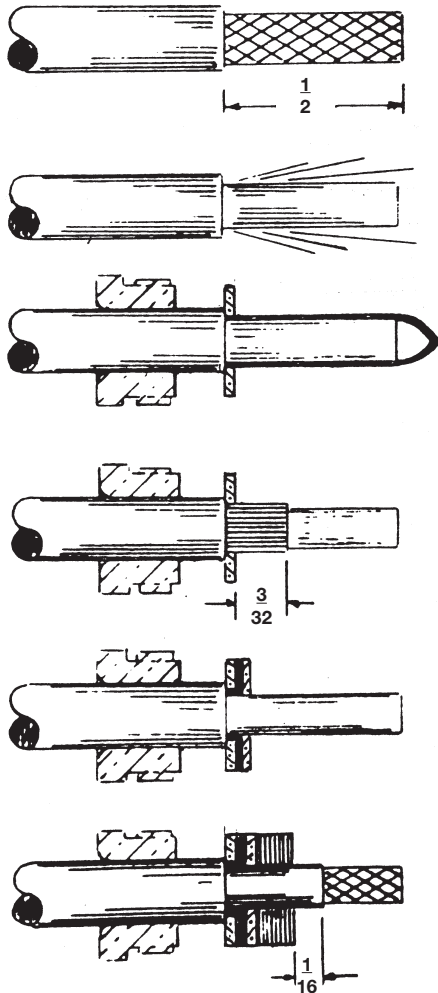

**Step 1** Cut off end of cable square and remove jacket as shown. Do not nick braid.

**Step 2** Comb out braid.

**Step 3** Taper braid, slide nut over jacket. Slide washer 'A' over braid.

**Step 4** Cut braid to dim. Shown. Do not nick inner jacket.

**Step 5** Flare braid. Trim if necessary. Slide washer 'B' over inner jacket. Push firmly against braid and washer 'A'.

**Step 6** Slide gasket over inner jacket. Push firmly into place. Trim inner jacket to dim. Shown. Do not nick braid.

(Continued on next page)

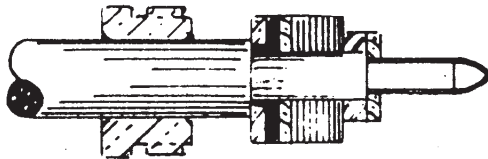

**Step 7** Taper braid, slide Teflon washer over inner jacket. Slide washer 'C' over braid. Push firmly into place.

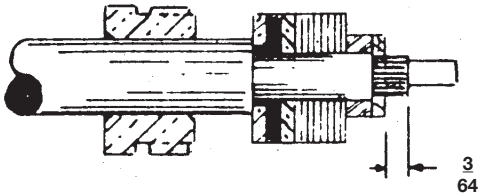

**Step 8** Cut inner braid to dim. Shown. Do not cut into dielectric.

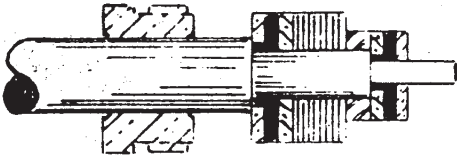

**Step 9** Flare braid. Trim if necessary. Slide washer 'D' over dielectric. Push firmly into place.

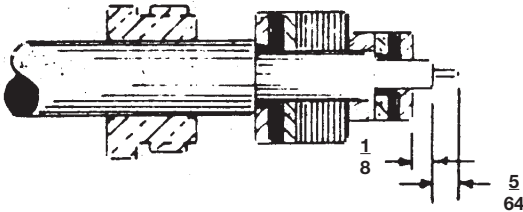

**Step 10** Cut dielectric and center contact to dimensions shown. Do not nick center conductor.

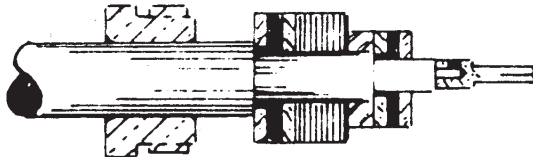

**Step 11** Solder contact to center conductor. Remove excess solder. Do not overheat.

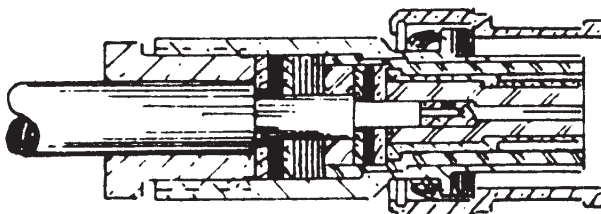

**Step 12** Insert completed cable hardware into inner insulator 'E', inner body 'F', and outer insulator 'G'. Now insert completed assy. into either jack or plug body. Tighten with wrench. Do not rotate body or cable.

NOTE: Tighten with wrench to 20-24 in. lbs.

# Assembly Instructions-C13 Triax BNC, TNC Threaded, 7/16-28

Note: For alternate Assembly instructions see sheet page 288

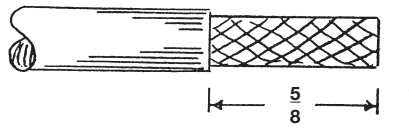
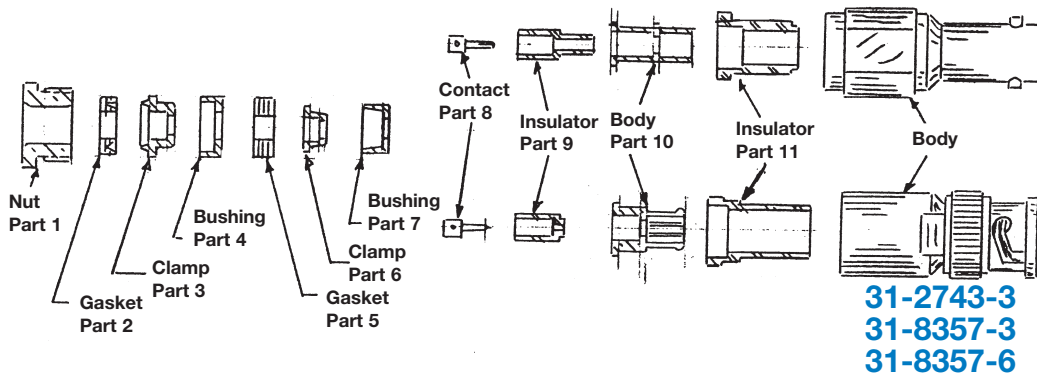

**Step 1** Cut off end of cable square and remove jacket to dim. Shown. Do not nick braid.



**Step 2** Comb out braid.

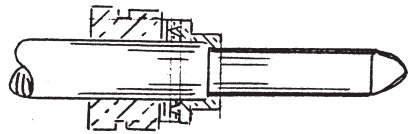

**Step 3** Taper braid, slide nut, gasket, and clamp over tapered braid making sure inner shoulder of clamp is positioned tightly against end of jacket.

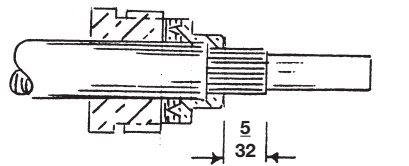

**Step 4** Trim braid to dim. Shown.

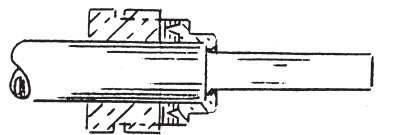

**Step 5** Flare back braid over clamp.

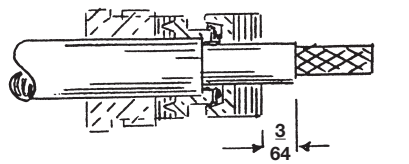

**Step 6** Place part (4) and part (5) in position shown. Remove inner jacket to dim. Shown.

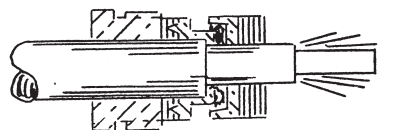

**Step 7** Comb out inner braid.

(Continued on next page)



# Assembly Instructions-C13

## Triax BNC, TNC Threaded, 7/16-28 (continued)

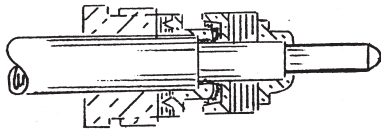

**Step 8** Taper braid, slide clamp part (6) over tapered inner braid making sure inner shoulder of clamp is positioned tightly against end of inner jacket.

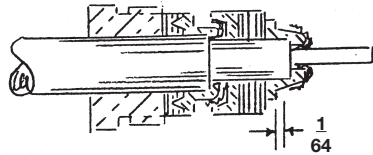

**Step 9** Fold back inner braid over clamp and trim inner braid to dim. Shown.

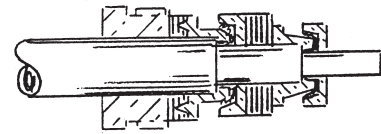

**Step 10** Place small bushing part (7) in position shown. Push firmly against braid.

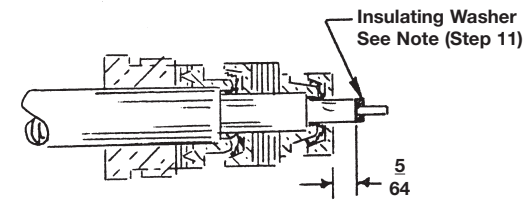

**Step 11** Trim dielectric to dim. Shown. Do not nick inner conductor.

**Note:** For assemblies 00-8354-4, 00-8354-5, 00-8470-2 and 00-8470-3 only, trim to 1/16 in lieu of 5/64, then assemble insulating washer.

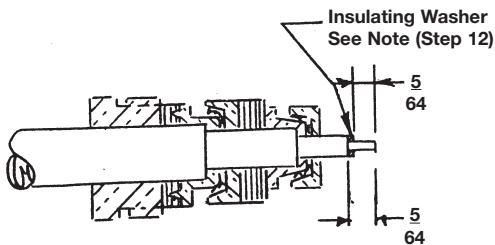

**Step 12** Trim inner conductor to dim. Shown.

**Note:** For assemblies 00-8354-4, 00-8354-5, 00-8470-2 and 00-8470-3 only, trim inner conductor to 5/64 with insulating washer assembled.

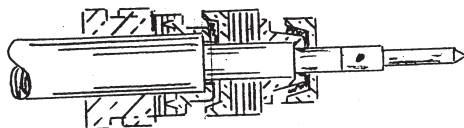

**Step 13** Solder contact on inner conductor. Remove excess solder. Do not overheat dielectric as it will distort and will not enter insulator properly.

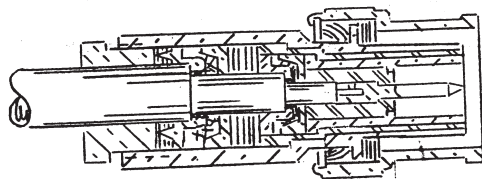

**Step 14** Insert completed cable hardware assy. into either Jack or Plug body. Make sure part (2) is properly seated on sharp edge of part (3). After nut is started, tighten with torque wrench to 13 to 15 in. lbs.

**Note:** Sharp edge of clamp part (3) must split gasket part (2).

## ALTERNATE ASSEMBLY INSTRUCTIONS

Gasket (Part #2), Clamp (Part #3) & Bushing (Part #4) is replaced by washer (Part #12).

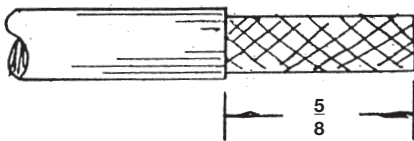
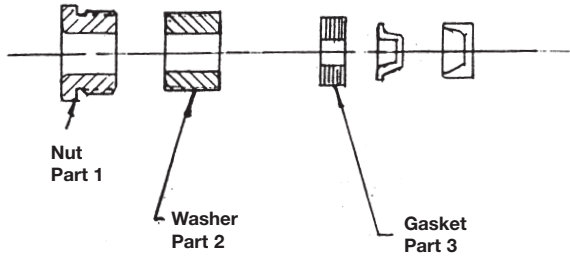

**Step 1A** Cut off end of cable square and remove jacket to dim's shown. Do not nick braid.

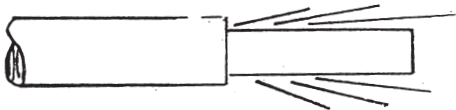

**Step 2A** Comb out braid.

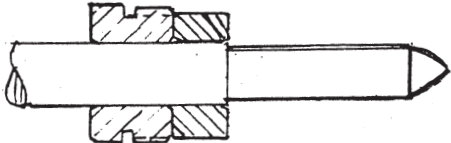

**Step 3A** Taper braid, slide washer over braid and jacket.

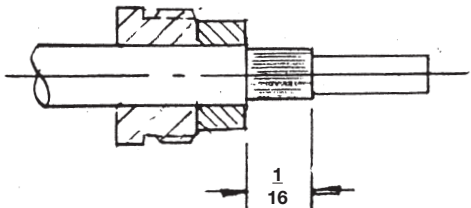

**Step 4A** Trim braid to dim shown.

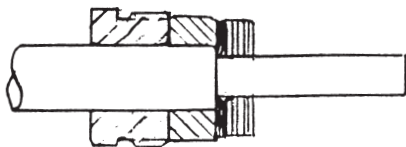

**Step 5A** Flare back braid to face of washer, and place gasket in position shown.

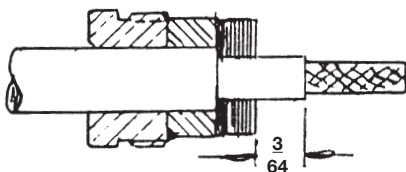

**Step 6A** Remove inner jacket to dim shown.

Continue as per inst. #7 of sheet page 72

# Assembly Instructions-C15

## Triax Threaded, 7/8-20 and 11/16-24

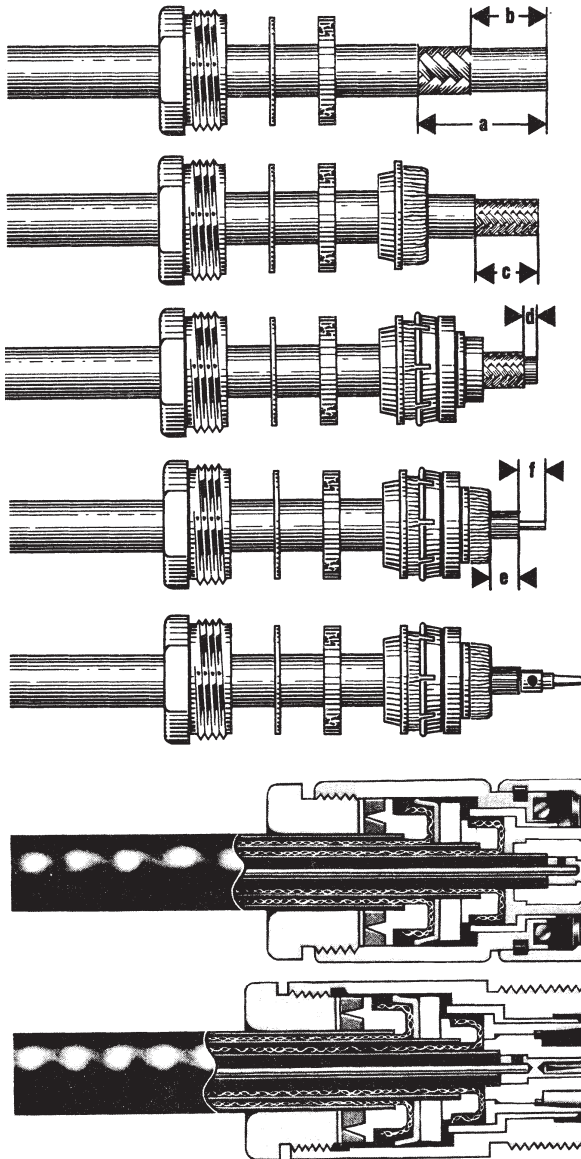
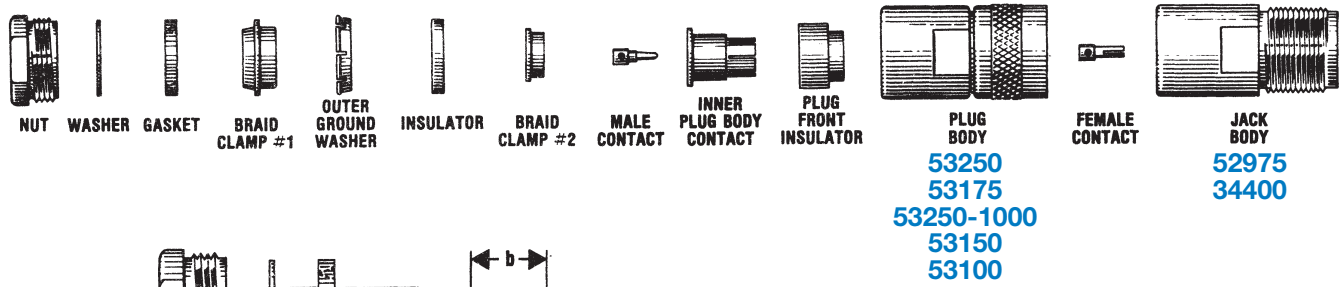

■ for 34400 and 34375 Jacks this dimension is .130 (3.3)

Δ for 53100 and 53150 Plugs this dimension is .187 (4.5)

- Step 1** Slide nut, washer and gasket over cable. Cut off outside jacket (using razor blade or wire strippers) to dimension a. Make a clean cut, being very careful not to nick braid. Cut first braid to dimension b.
- Step 2** Slide first braid clamp over braid up to jacket of cable. Fold first braid back over clamp, making sure braid is evenly distributed over the surface of the clamp. Trim second jacket to dimension c, again being very careful not to nick braid.
- Step 3** Trim second braid to dimension d. Slide on outer ground washer insulator and second braid clamp. Fold second braid back over braid clamp, again making sure that braid is evenly distributed over surface of clamp.
- Step 4** Trim cable dielectric to dimension e.
- Step 5** Tin the inside hole of the contact. Tin wire and insert into contact and solder. Remove any excess solder. Be sure cable dielectric is not heated excessively and swollen so as to prevent dielectric from entering body of fitting.
- Step 6** Plug only: Place front insulator and outer contact assembly into back of connector body and push into proper place. Insert cable-contact assembly into body. Screw nut into body with wrench until moderately tight.

**Stripping dims. ±1/64 inches  
(0.4 millimeters)**

Plugs	58A, 59 Type	8, 11 Type
a	7/8 (22.2)	15/16 (23.8)
b	19/32 (15.1)	19/32 (15.1)
c	9/16 (14.3)	15/32 (11.9)
d	11/32 (8.7)	5/16 (7.9)
e	11/32 (8.7)Δ	5/16 (7.9)
f	9/64 (3.6)	1/8 (3.2)
Jacks	58A, 59 Type	8 Type
a	19/32 (15.1)	29/32 (23.0)
b	21/64 (8.3)	19/32 (15.1)
c	19/64 (7.5)	9/16 (14.5)
d	1/4 (6.4)	5/16 (7.9)
e	1/4 (6.4) ■	5/16 (7.9)
f	3/32 (2.4)	1/8 (3.2)

Assembly

# Assembly Instructions-C16

## C - Two-Stud Bayonet Lock



CLAMP NUT



CLAMP GASKET



BRAID CLAMP



FEMALE CONTACT

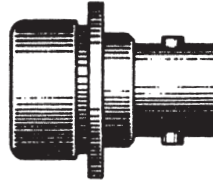

JACK BODY



MALE CONTACT

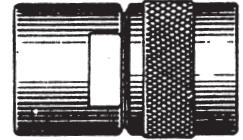

PLUG BODY

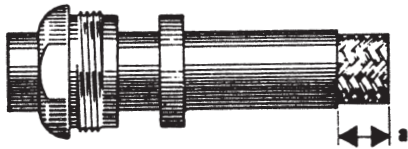

Slide nut and gasket over cable and cut jacket to dimension **a**.

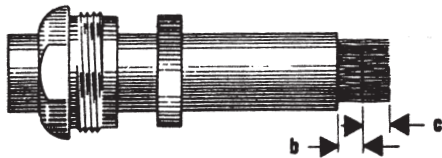

Comb out braid and fold out. Cut cable dielectric to dimension **b**.

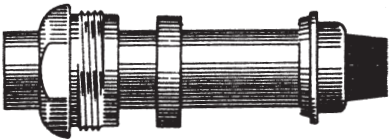

Pull braid wires forward and taper toward center conductor. Place clamp over braid and push back against cable jacket.

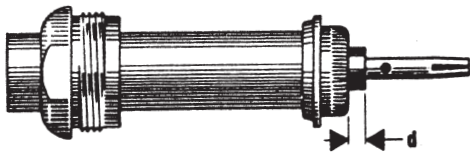

Fold back braid wires as shown, trim to proper length and form over clamp as shown. Solder contact to center conductor. Dimension **d** should be as shown.

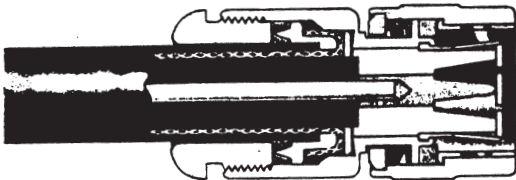

Insert cable and parts into connector body. Make sure sharp edge of clamp seats properly in gasket. Tighten nut. End of contact in plug should be flush with insulator. There should be a clearance of .010" (.25mm) between end of contact and insulator in jack.

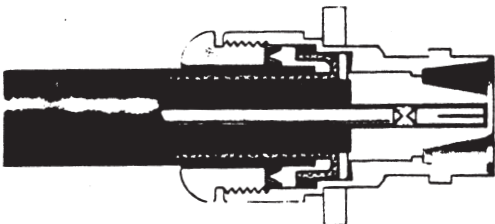

### Stripping dims. ±1/64 (0.4) inches (millimeters)

Amphenol Part #	a	b	c	d (ref)
82-530	9/32 (7.1)	1/8 (3.2)	5/32 (4.0)	3/64 (1.2)
82-532	19/23 (15.1)	7/16 (11.1)	5/32 (4.0)	11/32 (8.7)

- For armored cable slide cap over armor first. Push armor and cap back out of way and proceed with assembly as directed above using armor clamp in place of standard clamp nut. When assembly is complete, straighten bulge in armor and trim so that it can be clamped between nut and cap.

# Assembly Instructions-C17

## HN - Typical Clamp



### Stripping dims. inches (millimeters)

Amphenol Part #	a	b	c
82-804	1.00 (25.4)	.781 (19.8)	.219 (5.6)
82-856	.680 (17.3)	.34 (8.6)	.09 (2.3)
82-324	1.59 (40.4)	.875 (22.2)	.718 (18.2)

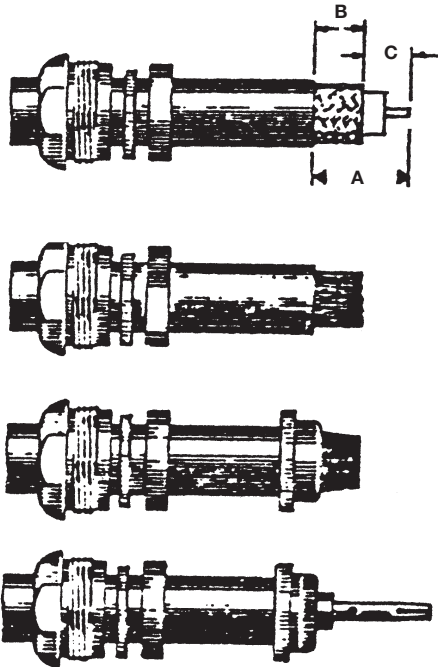

Place nut, gland, and gasket, with "V" groove toward nut, over cable and strip cable to dimensions as shown in table.

Comb out braid and fold out.

Pull braid wires forward and taper toward center conductor. Place clamp over braid and push back against cable jacket.

Fold back braid wires as shown, trim to proper length and form over clamp as shown. Solder contact to center conductor.

Insert cable and parts into connector body, make sure sharp edge of clamp seats properly in gasket. Tighten nut.  
Recommended Torque: 35-40 in lbs.

# Assembly Instructions-C18

## HN - Typical Clamp

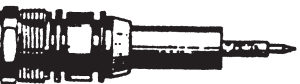
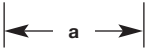
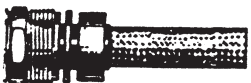
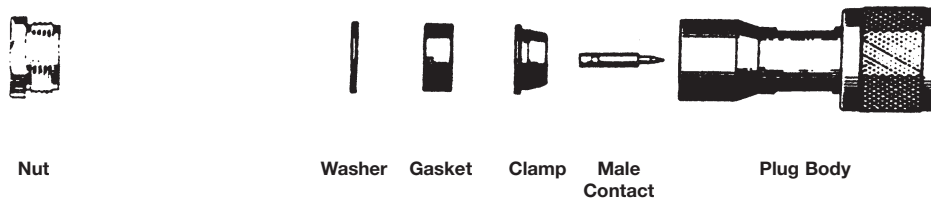

### Stripping dims. inches (millimeters)

Amphenol Part #	a	b	c
16750	.799 (20.2)	.594 (15.1)	.203 (5.8)
82-816-1000	.843 (21.4)	.625 (15.9)	.218 (5.5)

Push nut, washer and gasket over cable jacket.

Cut cable even to dimensions shown in table.

Push clamp over copper braid, flush against cable jacket. Cut exposed copper braid so that approximately 3/16 remains and fan over clamp. Trim braid even with end of taper. Cut cable dielectric (dim c) from end of cable cut. Tin exposed conductor.

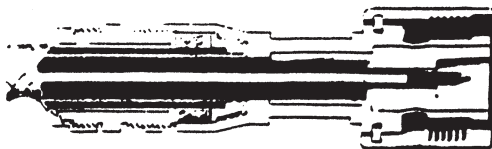

Solder contact pin to conductor. Do not overheat dielectric. Do not use excess solder. Wipe clean; see that dielectric is free from solder, resin and foreign material. Tighten nut to recommended torque 35-40 in lbs securely with wrench.

### CLAMP PLUGS

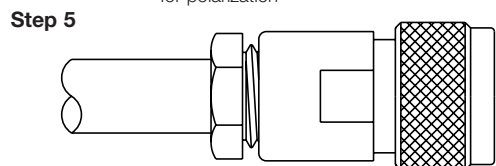
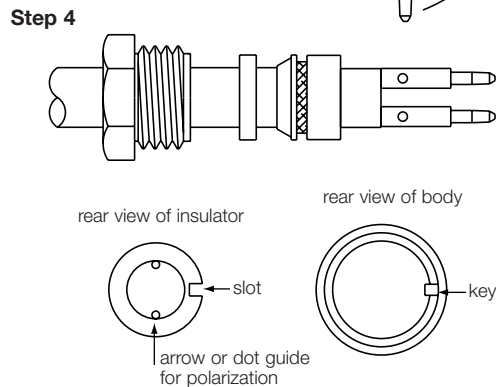
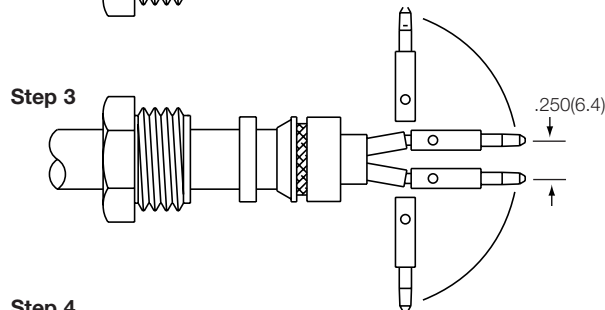
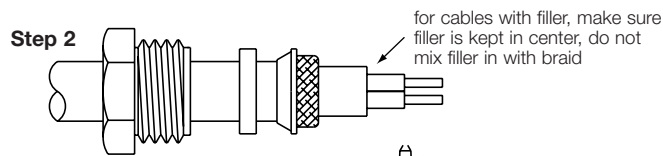
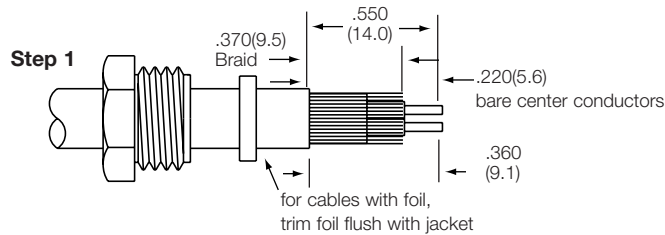
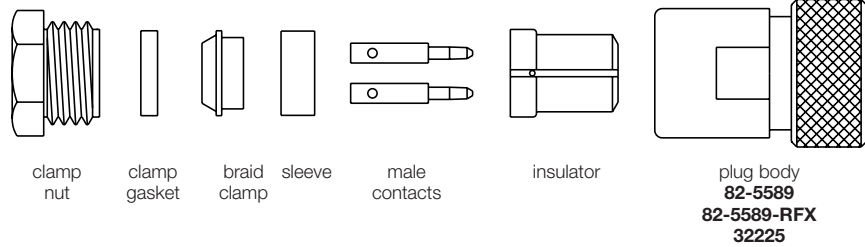

**Step 1** Slide clamp nut and clamp gasket over cable end. V-groove in clamp gasket faces toward connector body. Strip cable to dimensions shown. **Important:** Do not nick insulation around center conductors. For solid core cables, lay braid back out of way while trimming core; then lay braid down again to facilitate Step 2.

**Step 2** Slide braid clamp over braid until inner shoulder butts against jacket. (Note: sharp edge of braid clamp goes toward V-groove in clamp gasket.) Fold braid back evenly over braid clamp as shown.

**Step 3** Slide sleeve over cable so that braid bottoms inside sleeve. Solder contacts to conductors, using minimum heat. Remove any excess solder. Alternative method: Crimp center contacts using CTL Series tool number CTL-4 cavities B & C; or by using Die Set 227-1414 cavities B & C in tool frame 227-944 or in Pneumatic Crimp Tool 227-60. Bend conductors and contacts out and back to obtain .250(6.4) spacing between contacts.

**Step 4** Insert contacts into rear of insulator. (Note: for Belden 9207 and similar solid core cables, contact on bare copper conductor [or for Belden 8227 and similar air dielectric cables, the contact on white insulated conductor] goes into hole with dot next to it.) Slide insulator to butt against sleeve as shown.

**Step 5** Insert assembly into connector body, aligning slot of insulator with polarizing key in body. Tighten clamp nut to 50 lbf-in.(5.7 N·m) torque. Do not twist connector body.

# Assembly Instructions-C20

## HN - Typical Clamp

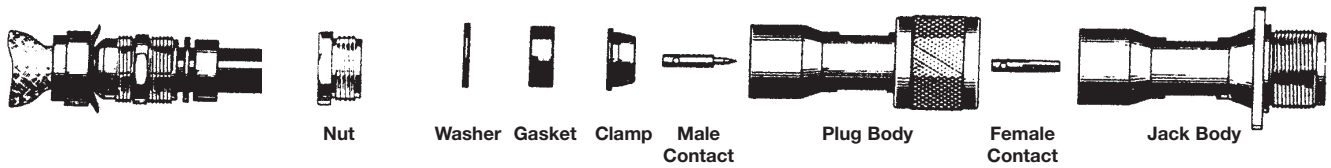

Cut end of cable even. Push nut, washer and gasket over cable jacket.

### Stripping dims. inches (millimeters)

Amphenol Part #	a	b	c
82-38	1.0 (25.4)	.781 (19.8)	.219 (5.6)

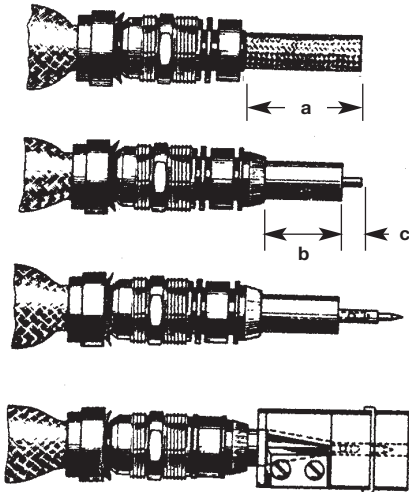

Remove vinyl jacket .798" (20.3) from end of cable. For double shield cables, remove vinyl jacket 1 3/16" (30.2) from end of cable.

Push clamp over copper braid, flush against cable jacket. Cut exposed copper braid so that approximately .219" (5.6) remains and fan over clamp. Trim braid even with end of taper. Cut cable dielectric to Dim c.

Solder contact pin to conductor. Do not overheat dielectric. Do not use excess solder. Wipe clean; see that dielectric is free from solder, resin and foreign material.

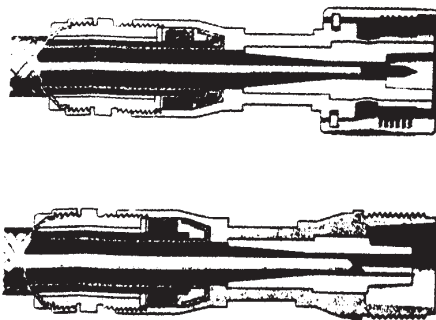

Taper dielectric with AMPHENOL 103-301 (MX-103/U) trimming tool. When tapering dielectric of cable for plug assembly, push contact stop of tool to bottom of slot. Tool will stop cutting when shoulder of contact butts against stop. Cable will be properly tapered when end of center contact is flush with end of trimmer body.

Apply small amount of Dow Corning DC-4 Silicone Compound or equivalent (per MIL-S-8660) on tapered surface of dielectric. Insert assembly into connector body. Tighten nut securely with wrench.



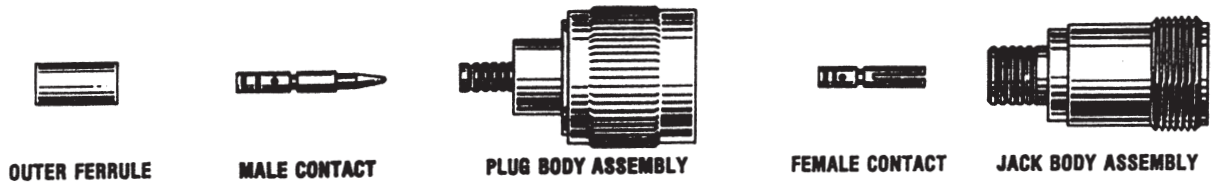

Amphenol Number	Connector Type	Cable RG-/U	Hex Crimp Data			CTL Series Tool Number	Stripping Dimensions, inches (mm)		
			Cavity for Contact	Cavity for Outer Ferrule	Die Set for Tool 227-944		a	b	c
82-4450	Plug	9, 214, 225, 393	.100 (2.5)	.429 (10.9)	227-1221-25	CTL-3	.687 (17.5)	.500 (12.7)	.406 (10.3)
82-4451	Plug	142B, 400	.100 (2.5)	.213 (5.4)	227-1221-57	CTL-3, -5	.687 (17.5)	.500 (12.7)	.406 (10.3)
82-4474	R/A Plug	9, 214, 225, 393	.100 (2.5)	.429 (10.9)	227-1221-25	CTL-3	.687 (17.5)	.500 (12.7)	.406 (10.3)
82-4475	R/A Plug	142B, 400	.100 (2.5)	.213 (5.4)	227-1221-57	CTL-3, -5	.687 (17.5)	.500 (12.7)	.406 (10.3)
82-4460	Panel Jack	9, 214, 225, 393	.100 (2.5)	.429 (10.9)	227-1221-25	CTL-3	.687 (17.5)	.500 (12.7)	.406 (10.3)
82-4454	Bulkhead Jack	214, 225, 393	.100 (2.5)	.213 (5.4)	227-1221-57	CTL-3, -5	.687 (17.5)	.500 (12.7)	.406 (10.3)

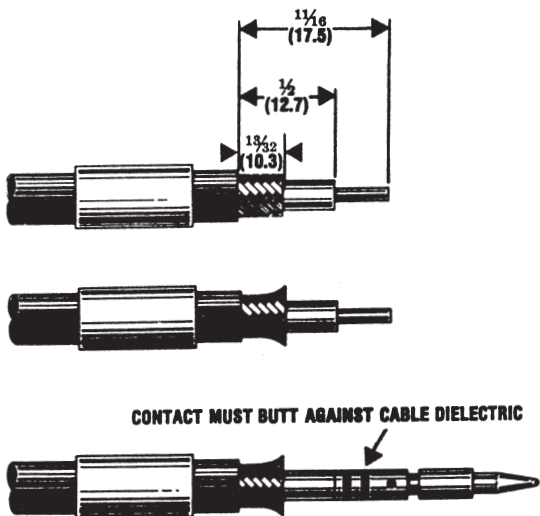

Strip cable jacket, braid, and dielectric to dimensions shown.  $\pm .010$  (.25). All cuts are to be sharp and square. Important: Do not nick braid, dielectric, and center conductor. Tinning of center conductor is not necessary if contact is to be crimped. For solder method, tin center conductor avoiding excessive heat. Slide outer ferrule onto cable as shown.

Flare slightly end of cable braid as shown to facilitate insertion onto inner ferrule. Important: Do not comb out braid.

Place contact on cable center conductor so that it butts against cable dielectric. Center conductor should be visible through inspection hole in contact. Crimp contact in place using tool handle and die cavity shown in table above or soft solder per QQ-5-571 COMP SN60.

Do not get any solder on outside surfaces of contact. Avoid excessive heat to prevent swelling of dielectric.

Install cable assembly into body assembly so that inner ferrule portion slides under braid. Push cable assembly forward until contact snaps into place in insulator. Slide outer ferrule over braid and up against connector body. Crimp outer ferrule using tool handle and die set cavity shown in table above.

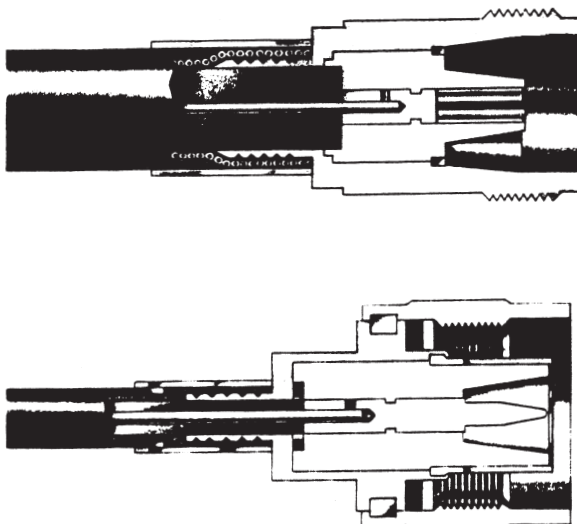

## CONNECTOR TERMINATION INSTRUCTIONS

Amphenol Number	Connector Type	Cable RG-/U	Hex Crimp Data			CTL Series Tool Number	Stripping Dimensions, inches (mm)		
			Cavity for Contact	Cavity for Outer Ferrule	Die Set for Tool 227-944		a	b	c
81-169	Plug	58, 141, 142	.068 (1.7)	.213 (5.3)	227-1221-11	CTL-1	.543 (13.8)	.217 (5.5)	.126 (3.2)
81-185-RFX	Plug	174, 188, 316	.042 or Solder	.128 (3.2)	227-1221-3	CTL-9	.465 (11.8)	.209 (5.3)	.091 (2.3)
81-160	Jack	58, 141, 142	.068 (1.7)	.213 (5.3)	227-1221-11	CTL-1	.559 (14.2)	.232 (5.9)	.157 (4.0)
81-186-RFX	Jack	58, 141, 142	.068 (1.7)	.213 (5.3)	227-1221-11	CTL-1	.559 (14.2)	.232 (5.9)	.157 (4.0)
81-187-RFX	Jack	174, 188, 316	.042 or Solder	.128 (3.2)	227-1221-3	CTL-9	.469 (11.9)	.201 (5.1)	.118 (3.0)

Step 1



**Step 1** Place ferrule on cable as shown. Strip cable to dimensions in table listed above.

**Step 2** Crimp center contact to cable using tools listed in table above.

Step 2



**Step 3** Assemble body to cable. Contact must snap in place. Slide ferrule over braid and crimp using tools listed in table above.

Step 3

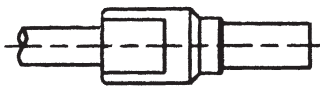

# Assembly Instructions-C23 Triax C Bayonet Lock

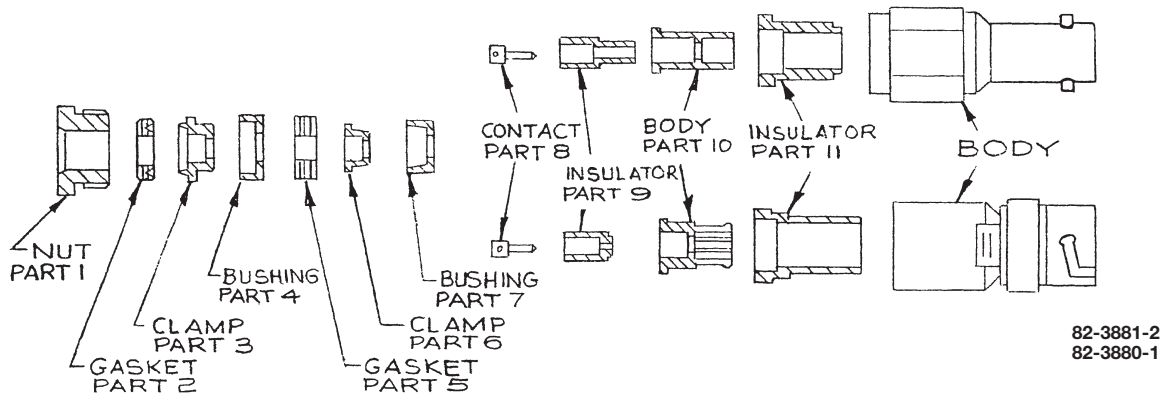

Step 1

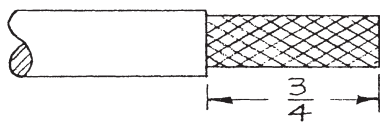

Step 1 Cut off end of cable and remove jacket to dim. shown. Do not nick braid.

Step 2

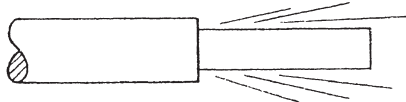

Step 2 Comb out braid.

Step 3

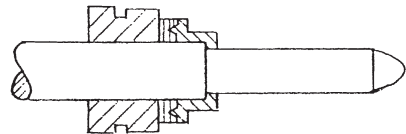

Step 3 Taper braid, slide nut, gasket and clamp over tapered braid making sure inner shoulder of clamp is positioned tightly against end of jacket.

Step 4

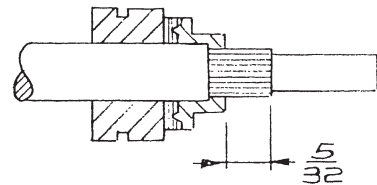

Step 4 Trim braid to dim. shown.

Step 5

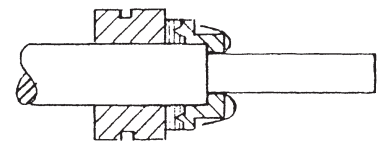

Step 5 Flare back braid over clamp.

Step 6

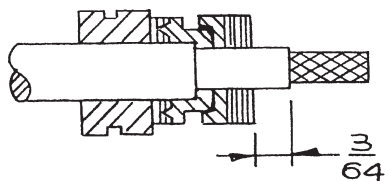

Step 6 Place part (4) and part (5) in position shown. Remove inner jacket to dim. shown.

Step 7

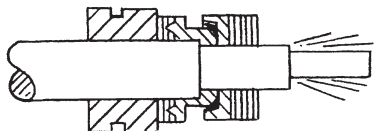

Step 7 Comb out inner braid.

# Assembly Instructions-C23

## Triax C Bayonet Lock (continued)

Step 8

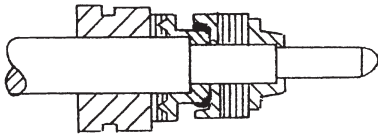

**Step 8** Taper braid, slide clamp part (6) over tapered inner braid making sure inner shoulder of clamp is positioned tightly against end of inner jacket.

Step 9

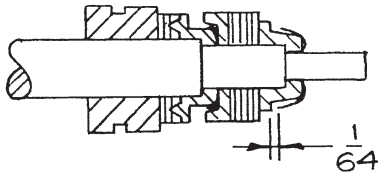

**Step 9** Fold back inner braid over clamp and trim inner braid to dim. shown.

Step 10

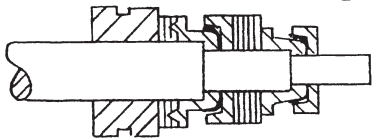

**Step 10** Place small bushing part (7) in position shown. Push firmly against braid.

Step 11

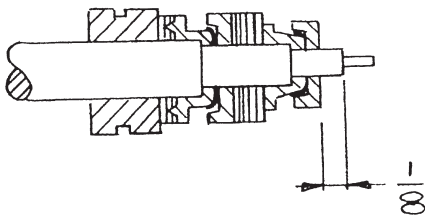

**Step 11** Trim dielectric to dim. shown. Do not nick inner conductor.

Step 12

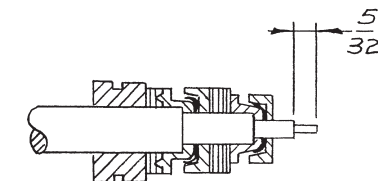

**Step 12** Trim inner conductor to dim. shown.

Step 13

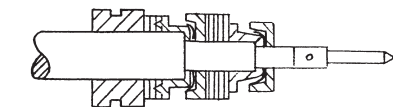

**Step 13** Solder contact on inner conductor. Remove excess solder. Do not overheat dielectric as it will distort and will not enter insulator properly.

Step 14

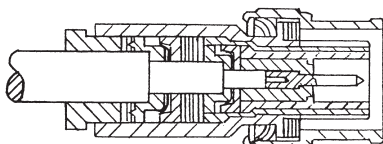

**Step 14** Insert complete cable hardware assembly into either Jack or Plug body. Make sure part (2) is properly seated on sharp edge of part (3). After nut is started, tighten with torque wrench to 25 ± 5 in. lbs.

**Note:** Sharp edge of clamp part (3) must split gasket part (2)

## CLAMP CONNECTORS

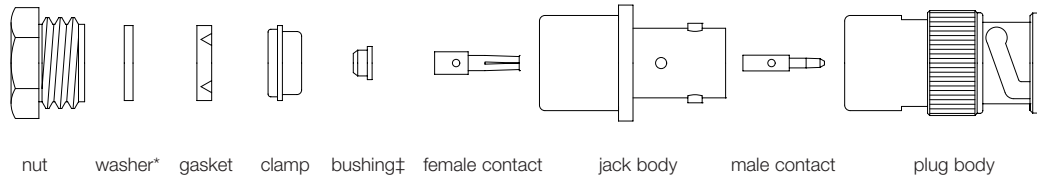

\* Not supplied on all items ‡ For use on RG-62, 71, 122, 178, 180, 196, 210

Amphenol Number	Connector Type	Cable RG-/U	Stripping Dims, Inches (Millimeters)	
			a	c
6775	BNC Plug	8, 9, 11, 213, 214	.490(12.4)	.200(5.1)
6775-75	75Ω BNC Plug	11	.490(12.4)	.200(5.1)
8525	BNC Angle Plug	58, 141, 142, 400	.343(8.7)	.187(4.7)
8575	BNC Angle Plug	59, 62, 140, 210	.297(7.5)	.094(2.4)
9350	BNC Plug	6	.405(10.3)	.094(2.4)
15875	BNC Plug	178, 196	.156(3.96)	.078(1.98)
16300	BNC Plug	180	.250(6.4)	.094(2.4)
33275	BNC Angle Plug	174, 179, 187, 188, 316	.540(13.7)	.156(3.96)
69475	BNC Plug	174, 179, 187, 188, 316	.281(7.1)	.172(4.4)
84975	BNC Plug	122	.281(7.1)	.172(4.4)
86350	BNC Bulkhead Jack	174, 179, 187, 188, 316	.265(6.73)	.156(3.96)
86425	BNC Panel Jack	174, 179, 187, 188, 316	.313(7.95)	.203(5.15)
86850	BNC Bulkhead Jack	178, 196	.266(6.75)	.109(2.76)
31-2	BNC Plug	58, 141, 142, 400	.312(7.9)	.094(2.4)
31-2-RFX	BNC Plug	58, 141, 142A	.315(8.0)	.118(3.0)
31-15	BNC Jack	59, 62, 71, 140, 210	.297(7.54)	.109(2.75)
31-202	BNC Plug	55, 58, 141, 142, 223, 400	.274(6.95)	.094(2.4)
31-204	BNC Angle Plug	55, 58, 141, 142, 223, 400	.297(7.54)	.109(2.8)
31-206	BNC Bulkhead Jack	58, 141, 142, 400	.297(7.5)	.109(2.8)
31-207	BNC Bulkhead Jack	59, 62, 71, 140, 210	.297(7.54)	.109(2.75)
31-212	BNC Plug	59, 62, 71, 140, 210, 302	.250(6.4)	.094(2.4)
31-212-1005	BNC Plug	59 (20GA CC)	.250(6.4)	.094(2.4)
31-850	BNC Angle Plug	59, 62, 71, 140, 210	.375(9.52)	.125(3.17)
31-3202	BNC Plug	55, 58, 141, 142, 223, 400	.250(6.4)	.094(2.4)
31-3301	BNC Plug	58, 141, 142, 223	.250(6.4)	.094(2.4)
31-3302	BNC Plug	59, 62, 71, 140, 210	.250(6.4)	.094(2.4)

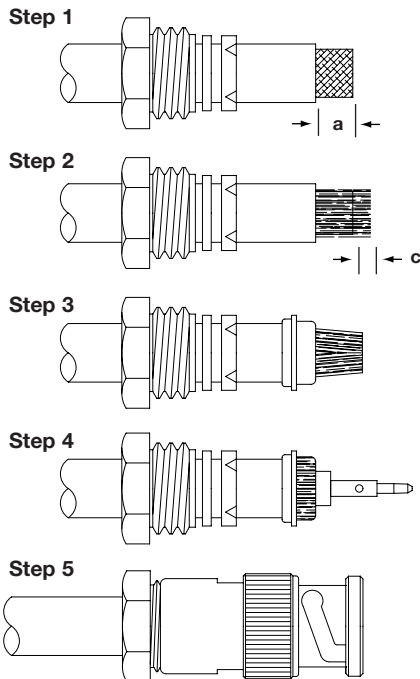

▲ For angle plugs only: (except 31-204) Solder center conductor to preassembled contact. Assemble cap and lightly punch center of cap for retention in body, or solder in place.

- Step 1** Place nut, washer (when supplied) and gasket over cable and strip jacket to dimension **a** shown in table above.
- Step 2** Comb out braid and fold out. Trim insulation off center conductor to dimension **c** shown in table above. [For RG-62, 71 and 210/U cable, trim an additional .032"(0.8mm) of insulation off center conductor and add bushing.] Tin center conductor.
- Step 3** Pull braid wires forward and taper toward center conductor. Place clamp over braid and push back against cable jacket.
- Step 4** Fold back braid wires as shown, trim to proper length [approximately .125" (3.2mm) long] and form over clamp as shown. Braid wire should not extend beyond step of braid clamp. Solder contact to center conductor, sliding bushing first (when supplied) over center conductor. ▲
- Step 5** Insert cable and parts into connector body. Make sure sharp edge of clamp seats properly in gasket. Tighten nut to approximately 15 inch pounds.

Assembly

# Assembly Instructions-C26 BNC

## 3-PIECE CRIMP PLUGS

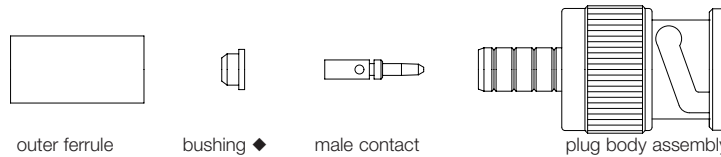

◆ used with RG-62, 71, 210 cable only

Amphenol Number	Connector Type	Cable RG-/U	Hex Crimp Data				Stripping Dimensions, inches (mm)		
			Cavity for Contact	Cavity for Outer Ferrule	Die Set for Tool 227-944*	CTL Series Tool Number	a	b	c
36650-1003	BNC Plug	Belden 82907, 88240 89907, Plenum 58	.068(1.7)	.178(4.5)	227-1221-9	CTL-2	.593(15.1)	.250(6.4)	.156(4.0)
36650-3RFX	BNC Plug	Plenum 58	.068(1.7)	.213(5.4)	227-1221-11	CTL-1	.630(16.0)	.319(8.1)	.157(4.0)
36875	BNC Plug	55, 142, 223, 400	.068(1.7)	.213(5.4)	227-1221-11	CTL-1	.593(15.1)	.250(6.4)	.156(4.0)
68175-1003	BNC Plug	Belden 9259	.068(1.7)	.255(6.5)	227-1221-13	CTL-1	.593(15.1)	.250(6.4)	.156(4.0)
68175-1005	BNC Plug	59 (20AG CC)	.068(1.7)	.255(6.5)	227-1221-13	CTL-1	.593(15.1)	.250(6.4)	.156(4.0)
68175-1011	BNC Plug	Belden 1560A, 82259, 89259, Plenum 59, 62	.068(1.7)	.255(6.5)	227-1221-13	CTL-1	.593(15.1)	.250(6.4)	.156(4.0)
68175-11RFX	BNC Plug	Plenum 59, 62	.068(1.7)	.255(6.5)	227-1221-13	CTL-1	.630(16.0)	.303(7.7)	.157(4.0)
68175-5RFX	BNC Plug	59 (20GA CC)	.068(1.7)	.255(6.5)	227-1221-13	CTL-1	.630(16.0)	.303(7.7)	.157(4.0)
31-242	BNC Plug	179, 187	.068(1.7)	.178(4.5)	227-1221-9	CTL-2	.593(15.1)	.250(6.4)	.156(4.0)
31-242-RFX	BNC Plug	179, 187	.068(1.7)	.178(4.5)	227-1221-9	CTL-2	.590(15.0)	.323(8.2)	.118(3.0)
31-315	BNC Plug	174, 188, 316	.068(1.7)	.178(4.5)	227-1221-9	CTL-2	.593(15.1)	.250(6.4)	.156(4.0)
31-315-RFX	BNC Plug	174, 188, 316	.068(1.7)	.178(4.5)	227-1221-9	CTL-2	.593(15.1)	.250(6.4)	.156(4.0)
31-315-1005	BNC Plug	Dbl. Br. 316	.068(1.7)	.178(4.5)	227-1221-9	CTL-2	.593(15.1)	.250(6.4)	.156(4.0)
31-320	BNC Plug	58, 141	.068(1.7)	.213(5.4)	227-1221-11	CTL-1	.593(15.1)	.250(6.4)	.156(4.0)
31-320-RFX	BNC Plug	58, 141, 142A	.068(1.7)	.213(5.4)	227-1221-11	CTL-1	.630(16.0)	.303(7.7)	.156(4.0)
31-320-1006	BNC Plug	Belden 9907, 89907	.068(1.7)	.213(5.4)	227-1221-11	CTL-1	.593(15.1)	.250(6.4)	.156(4.0)
31-321	BNC Plug	59, 62	.068(1.7)	.255(6.5)	227-1221-13	CTL-1	.593(15.1)	.250(6.4)	.156(4.0)
31-321-RFX	BNC Plug	59, 62	.068(1.7)	.255(6.5)	227-1221-13	CTL-1	.630(16.0)	.303(7.7)	.156(4.0)
31-321-1000	BNC Plug	Belden 8281, 88281	.068(1.7)	.324(8.2)	227-1221-32	CTL-2	.593(15.1)	.250(6.4)	.156(4.0)
31-321-10RFX	BNC Plug	Belden 8281	.068(1.7)	.324(8.2)	227-1221-32	CTL-2	.630(16.0)	.303(7.7)	.156(4.0)
31-325	BNC Plug	Belden 8218	.068(1.7)	.178(4.5)	227-1221-9	CTL-2	.593(15.1)	.250(6.4)	.156(4.0)
31-326	BNC Plug	55, 142, 223	.068(1.7)	.213(5.4)	227-1221-11	CTL-1	.593(15.1)	.250(6.4)	.156(4.0)
31-326-RFX	BNC Plug	55, 142, 223, 400	.068(1.7)	.213(5.4)	227-1221-11	CTL-1	.593(15.1)	.250(6.4)	.156(4.0)
31-4320	BNC Plug	58, 141	.068(1.7)	.213(5.4)	227-1221-11	CTL-1	.593(15.1)	.250(6.4)	.156(4.0)
31-4321	BNC Plug	59, 62	.068(1.7)	.255(6.5)	227-1221-13	CTL-1	.593(15.1)	.250(6.4)	.156(4.0)
31-4411	BNC Plug	Belden 8213	.100(2.5)	.429(10.9)	227-1221-25	CTL-3	.650(16.5)	.250(6.4)	.156(4.0)
31-4427	BNC Plug	142, 400	.068(1.7)	.213(5.4)	227-1221-11	CTL-1	.593(15.1)	.250(6.4)	.156(4.0)
31-5558-RFX	BNC Plug	6 Type (.314OD)	.068(1.7)	.324(8.2)	227-1221-32	CTL-2	.630(16.0)	.303(7.7)	.156(4.0)
31-5800	BNC Plug	58, 141, PL-58	.068(1.7)	.213(5.4)	227-1221-11	CTL-1	.593(15.1)	.250(6.4)	.156(4.0)
31-5900	BNC Plug	59, 62, 59 (20GA CC), Plenum -59, 62	.068(1.7)	.255(6.5)	227-1221-13	CTL-1	.593(15.1)	.250(6.4)	.156(4.0)

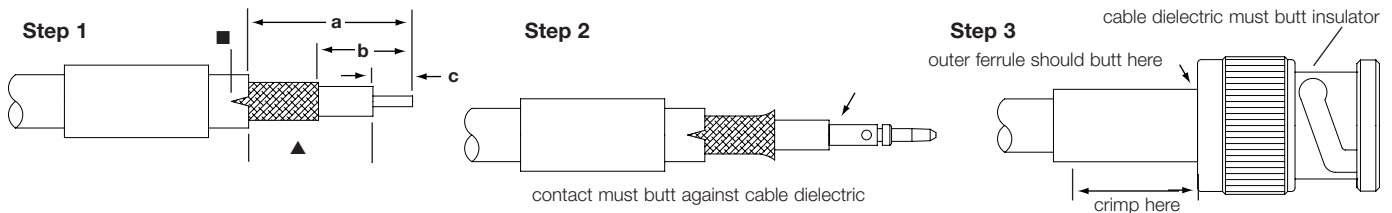

**Step 1** Strip cable jacket, braid, and dielectric to dimensions in table above. [for RG-62,71,210/U cable, trim an additional .039"(1.0mm) of insulation off center conductor and add bushing] All cuts are to be sharp and square. Important: Do not nick braid, dielectric, and center conductor. Slide outer ferrule onto cable as shown.

**Step 2** Flare slightly end of cable braid as shown to facilitate insertion of inner ferrule. Important: Do not comb out braid ▲. Place contact on cable center conductor so that it butts against cable dielectric. Crimp contact in place using Die Set Cavity indicated in table above. When using RG-62, 71, 210 cable, install bushing over center conductor before installing contact.

**Step 3** Install cable assembly into body assembly so that inner ferrule portion slides under braid. Push cable assembly forward until contact snaps into place in insulator. Slide outer ferrule over braid and up against connector body. Crimp outer ferrule using Die Set Cavity specified in table above.

▲ For RG-174, 179, 187, 188, 316/U cables only, slit jacket back .100"(2.5mm) as shown. Before attaching center contact, slide metal spacer/TFE sleeve (not shown) over cable dielectric and under braid. The center contact should butt against the dielectric and TFE sleeve.

\* for pneumatic crimp tool 227-60, use die sets indicated in this column.

### 3-PIECE CRIMP ANGLE PLUGS & BULKHEAD JACKS

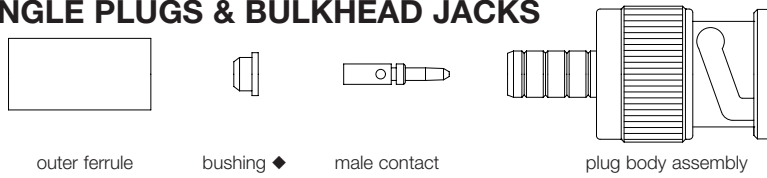

◆ used with RG-62, 71, 210 cable only

Amphenol Number	Connector Type	Cable RG-/U	Hex Crimp Data				Stripping Dimensions, inches (mm)		
			Cavity for Contact	Cavity for Outer Ferrule	Die Set for Tool 227-944*	CTL Series Tool Number	a	b	c
36800	BNC Jack	58, 141	.068(1.7)	.213(5.4)	227-1221-11	CTL-1	.593(15.1)	.250(6.4)	.156(4.0)
36800-RFX	BNC Jack	58, 141	.068(1.7)	.213(5.4)	227-1221-11	CTL-1	.630(16.0)	.303(7.7)	.156(4.0)
68150	BNC Jack	59, 62, 140	.068(1.7)	.255(6.5)	227-1221-13	CTL-1	.593(15.1)	.250(6.4)	.156(4.0)
95700	BNC Bulkhead Jack	55, 142, 223	.068(1.7)	.213(5.4)	227-1221-11	CTL-1	.593(15.1)	.250(6.4)	.156(4.0)
31-245	BNC Bulkhead Jack	179, 187	.068(1.7)	.178(4.5)	227-1221-9	CTL-2	.593(15.1)	.250(6.4)	.156(4.0)
31-316	BNC Angle Plug	174, 188, 316	.068(1.7)	.178(4.5)	227-1221-9	CTL-2	.578(14.6)	.328(8.3)	.125(3.1)
31-317	BNC Jack	174, 188, 316	.068(1.7)	.178(4.5)	227-1221-9	CTL-2	.593(15.1)	.250(6.4)	.156(4.0)
31-318	BNC Bulkhead Jack	174, 188, 316	.068(1.7)	.178(4.5)	227-1221-9	CTL-2	.593(15.1)	.250(6.4)	.156(4.0)
31-318-RFX	BNC Bulkhead Jack	174, 188, 316	.068(1.7)	.178(4.5)	227-1221-9	CTL-2	.630(16.0)	.362(9.2)	.156(4.0)
31-318-1001	BNC Bulkhead Jack	DbL Br. 316	.068(1.7)	.178(4.5)	227-1221-9	CTL-2	.593(15.1)	.250(6.4)	.156(4.0)
31-245-RFX	BNC Bulkhead Jack	179, 187	.068(1.7)	.178(4.5)	227-1221-9	CTL-2	.630(16.0)	.362(9.2)	.156(4.0)
31-334	BNC Angle Plug	55, 142, 223, 400	.068(1.7)	.213(5.4)	227-1221-11	CTL-1	.578(14.6)	.328(8.3)	.125(3.1)
31-335	BNC Angle Plug	58, 141	.068(1.7)	.213(5.4)	227-1221-11	CTL-1	.578(14.7)	.328(8.3)	.125(3.2)
31-335-RFX	BNC Angle Plug	58, 144	.068(1.7)	.213(5.4)	227-1221-11	CTL-1	.677(17.2)	.350(8.9)	.156(4.0)
31-336	BNC Angle Plug	59, 62	.068(1.7)	.255(6.5)	227-1221-13	CTL-1	.578(14.7)	.328(8.3)	.125(3.2)
31-336-RFX	BNC Angle Plug	59, 62	.068(1.7)	.255(6.5)	227-1221-13	CTL-1	.677(17.2)	.350(8.9)	.156(4.0)
31-342	BNC Bulkhead Jack	58, 141	.068(1.7)	.213(5.4)	227-1221-11	CTL-1	.593(15.1)	.250(6.4)	.156(4.0)
31-342-RFX	BNC Bulkhead Jack	58, 141, 142, 223	.068(1.7)	.213(5.4)	227-1221-11	CTL-1	.689(17.5)	.362(9.2)	.157(4.0)
31-343-1002	BNC Bulkhead Jack	Pl. 59 (20 AWG)	.068(1.7)	.255(6.5)	227-1221-13	CTL-1	.593(15.1)	.250(6.4)	.156(4.0)
31-343-RFX	BNC Bulkhead Jack	59, 62, 140, 210	.068(1.7)	.255(6.5)	227-1221-11	CTL-1	.689(17.5)	.362(9.2)	.157(4.0)
31-4327	BNC Jack	58, 141	.068(1.7)	.213(5.4)	227-1221-11	CTL-1	.593(15.1)	.250(6.4)	.156(4.0)
31-5911-RFX	BNC Angle Plug	58, 141	Solder	.213	227-1221-11	CTL-1,3,5	.709(18.0)	.382(9.7)	.161(4.1)
31-5914-RFX	BNC Angle Plug	59	Solder	.255	227-1221-13	CTL-1,5,6,8	.709(18.0)	.382(9.7)	.161(4.1)
31-5991-RFX	BNC Angle Plug	316	Solder	.128	227-1221-3	CTL-9,13	.618(15.7)	.350(8.9)	.157(4.0)
31-316-RFX	BNC Angle Plug	316	Solder	.128	227-1221-3	CTL-9,13	.618(15.7)	.350(8.9)	.157(4.0)
31-70239	BNC Angle Plug	734A	.042	.255	—	CTL-14	.630 (16.0)	.303 (7.7)	.157 (4.0)
31-70240	BNC Angle Plug	735A	.042	.187	—	CTL-15	.630 (16.0)	.303 (7.7)	.157 (4.0)
31-70234	BNC Plug	Beld 1694	.042	.319	—	CTL-14	.630 (16.0)	.303 (7.7)	.157 (4.0)
31-70235	BNC Plug	Beld 8281	.042	.324	—	CTL-14	.630 (16.0)	.303 (7.7)	.157 (4.0)
31-70236	BNC Plug	Beld 8218	.042	.178	—	CTL-15	.630 (16.0)	.303 (7.7)	.157 (4.0)
31-70237	BNC Plug	734A	.042	.255	—	CTL-14	.630 (16.0)	.303 (7.7)	.157 (4.0)
31-70238	BNC Plug	735A	.042	.187	—	CTL-15	.630 (16.0)	.303 (7.7)	.157 (4.0)
31-315-RFX	BNC Plug	174,188,316	.068	.178	227-1221-9	CTL-2	.593 (15.1)	.250 (6.4)	.156 (4.0)
31-317-RFX	BNC Jack	174,188,316	.068	.178	227-1221-9	CTL-2	.634 (16.1)	.303 (7.7)	.156 (4.0)
31-335-RFX	BNC Angle Plug	58,141,142	.068	.213	227-1221-11	CTL-1,5	.677 (17.2)	.350 (8.9)	.157 (4.0)
31-5998-RFX	BNC Plug	B8214,B9913,B9914	.118	.429	227-1221-61	CTL-11	.630 (16)	.303 (7.7)	.157 (4.0)
31-5999-RFX	BNC Plug	8x,LMR240	.068	.255	227-1221-13	CTL-1,5	.630 (16)	.303 (7.7)	.157 (4.0)
31-6004-RFX	BNC Angle Plug	B9913,B9914	Solder	.429	227-1221-25	CTL-4	.728 (18.5)	.401 (10.2)	.244 (6.2)
31-6005-RFX	BNC Angle Plug	8x,LMR240	Solder	.255	227-1221-13	CTL-1,5	.728 (18.5)	.401 (10.2)	.244 (6.2)
31-6006	BNC Plug	8x,LMR240	.068	.255	227-1221-13	CTL-1,5	.593 (15.1)	.250 (6.4)	.156 (4.0)

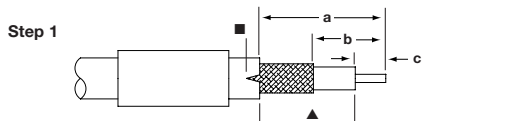

▲ For RG-174, 179, 187, 188, 316/U cables only, slit jacket back .100"(2.5mm) as shown. Before attaching center contact, slide metal spacer/TFE sleeve (not shown) over cable dielectric and under braid. The center contact should butt against the dielectric and TFE sleeve.

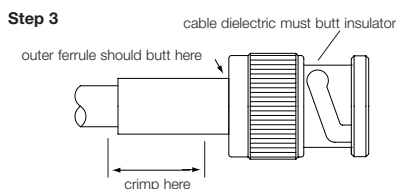
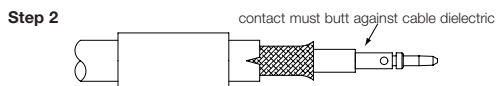

**Step 1** Strip cable jacket, braid, and dielectric to dimensions in table above. [for RG-62,71,210/U cable, trim an additional .039"(1.0mm) of insulation off center conductor and add bushing] All cuts are to be sharp and square. Important: Do not nick braid, dielectric, and center conductor. Slide outer ferrule onto cable as shown.

**Step 2** Flare slightly end of cable braid as shown to facilitate insertion of inner ferrule. Important: Do not comb out braid ▲. Place contact on cable center conductor so that it butts against cable dielectric. Crimp contact in place using Die Set Cavity indicated in table above. When using RG-62, 71, 210 cable, install bushing onto center conductor before installing contact.

**Step 3** Install cable assembly into body assembly so that inner ferrule portion slides under braid. Push cable assembly forward until contact snaps into place in insulator. Slide outer ferrule over braid and up against connector body. Crimp outer ferrule using Die Set Cavity specified in table above.

\* for pneumatic crimp tool 227-60, use die sets indicated in this column

## ORIGINAL CRIMP PLUGS

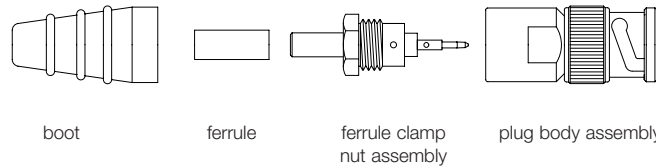

Amphenol Number	Connector Type	Cable RG-/U	Hex Crimp Data			Stripping Dimensions, inches (mm)		
			Cavity for Contact	Cavity for Outer Ferrule	Die Set for Tool 227-944*	a	b	c
31-351	BNC Plug	58, 141	—	.213(5.4)	227-1221-11	.922(23.4)	.516(13.1)	.250(6.3)
31-359	BNC Plug	59, 62, 140	—	.255(6.5)	227-1221-13	.922(23.4)	.516(13.1)	.250(6.3)
31-371	BNC Plug	174, 179, 187, 188, 316	—	.128(3.2)	227-1221-3	.797(20.2)	.516(13.1)	.250(6.3)

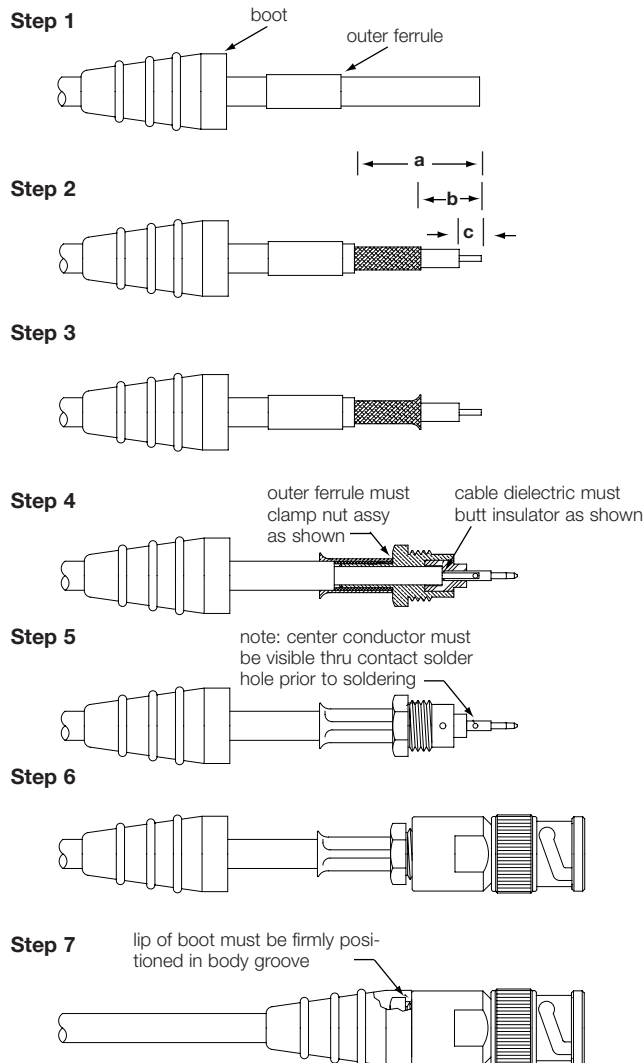

- Step 1** Install boot and slide outer ferrule onto cable as shown prior to stripping cable.
- Step 2** Strip cable jacket, braid and dielectric to dimensions shown. See attached table for dimensions. All cuts are to be sharp and square. Important: DO NOT nick braid, dielectric, and center conductor when cutting. Tin center conductor using soft solder per QQ-S-571 comp Sn 60. Avoid excessive heat while tinning to prevent swelling of cable dielectric.
- Step 3** Slightly flare out end of cable braid as so as to facilitate insertion onto ferrule clamp nut assembly. Important: DO NOT comb out braid.
- Step 4** Install ferrule clamp nut assembly onto cable so that ferrule portion slides under braid and insulator butts flush against cable dielectric. Slide outer ferrule over braid and up against nut. Make sure no slack exists in braid. Crimp outer ferrule with tool specified in table above, keeping cable dielectric bottomed against insulator.
- Step 5** Soft solder center conductor to contact using rosin core per QQ-S-571 comp Sn 60. DO NOT get any solder on outside surfaces of contact.
- Step 6** Screw connector body onto prepared cable termination . Wrench tighten by holding the cable nut assembly STATIONARY while ROTATING the connector body.
- Step 7** Push body forward and into position as shown to complete assembly.

\* for pneumatic crimp tool 227-60, use die sets indicated in this column



## SURETWIST® PLUG

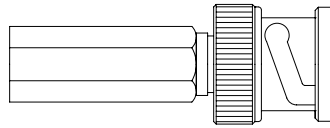

BNC SURETWIST® plug

Amphenol Number	Connector Type	Cable RG-/U
31-5136	BNC Plug	59
31-5136-RFX	BNC Plug	59
31-5137	BNC Plug	58
31-5137-RFX	BNC Plug	58

Step 1

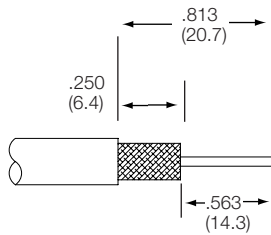

**Step 1** Strip cable as shown. Take care not to nick center conductor or outer braid.

Step 2

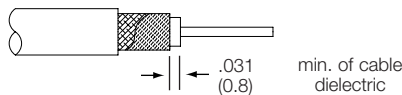

**Step 2** Twist outer braid in a clockwise direction so that at least 1/32" of cable dielectric is bared, and braid is left flat. (Stray or loose braid can cause shorts.)

Step 3

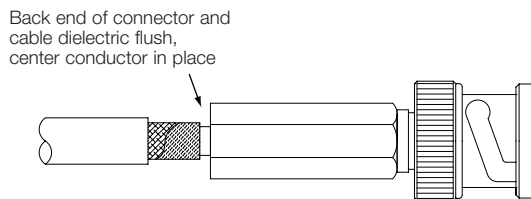

**Step 3** Gently insert center conductor into back end of connector, "feeling" it into the guide hole. (If center conductor is NOT properly in place, about 1/8" of center conductor will show at the back end. Reinsert until cable dielectric reaches position shown in illustration.)

Step 4

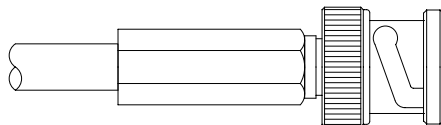

**Step 4** Push the cable firmly home (as far as possible). Then screw the connector onto the cable in a clockwise direction until it stops. Assembly is complete.

## QUICKTRIM® PLUG

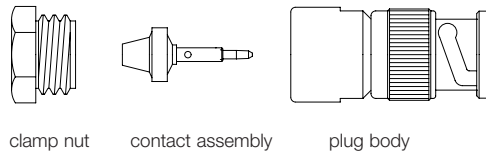

Amphenol Number	Connector Type	Cable RG-/U	Center Contact Affixment		
			Hex Size	Die Set for Tool 227-944*	CTL Series Tool Number
31-4541	BNC Plug	59, 59A, 62, 62A	.068(1.7)	227-1221-13 Cavity B	CTL-1
31-4541-RFX					
31-4542	BNC Plug	Belden 9268 Montrose CBL-5098			
31-30220-1	BNC Plug	58			
31-30220-8	BNC Plug	223			

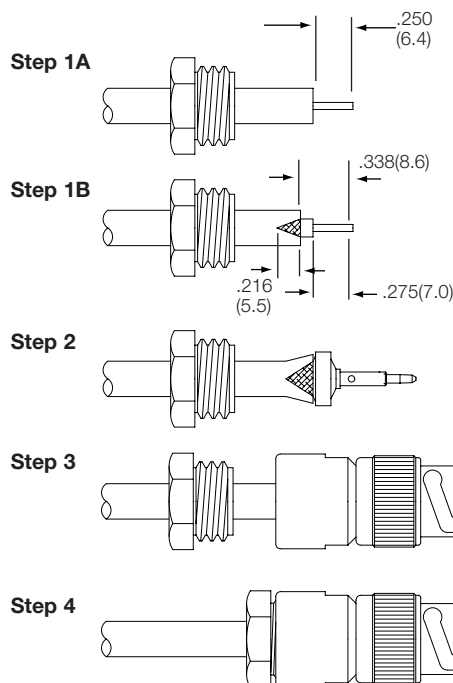

**Step 1A** For all connectors except 31-4541-RFX (see step 1B). Slide clamp nut over cable. Strip cable to dimension shown. Cut braid and dielectric square. Do not nick center conductor.

**Step 1B** For 31-4541-RFX.. Same as step 1A except use Step 1B strip dimensions, and then slit jacket back .125"(3.2 mm) in four places 90° apart as shown in illustration.

**Step 2** Slide contact assembly under braid and jacket until braid butts as shown. Use caution that braid slides over contact assembly and not inside of it. Be sure center conductor is visible through side hole of contact. Solder contact to center conductor. Contact may be crimped on applicable connectors using Amphenol CTL-1 crimp tool; or by using die set 227-1221-13 cavity B in tool frame 227-944 or equivalent tool.

**Step 3** Insert into connector body.

**Step 4** Tighten clamp nut to a torque of 35 lbf-in.

\* for pneumatic crimp tool 227-60, use die sets indicated in this column

## PLUGS FCP TERMINATION

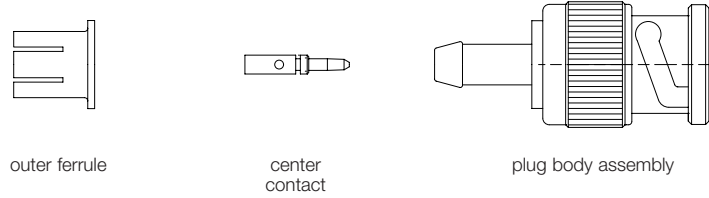

Amphenol Number	Connector Type	Cable RG-/U
31-4700	BNC Plug	58, 141
31-4702	BNC Plug	59

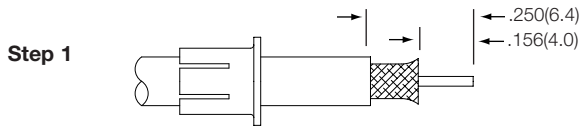

**Step 1** Slide ferrule over cable end, slotted end first. Strip cable to dimensions shown. Do not nick center conductor. Flare braid slightly as shown.

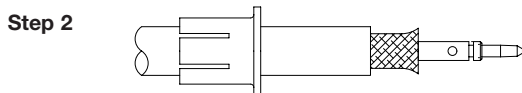

**Step 2** Tin exposed center conductor. Solder center contact on center conductor. Use minimum heat to avoid damaging cable insulation. Remove any excess solder and flux from contact surface. Contact may be crimped using 227-1221-11 die set (cavity B) .068 hex in tool handle 227-944 or equivalent tool.

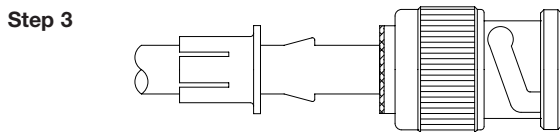

**Step 3** Slide body over contact and cable insulation with barb going UNDER flared braid. Push body until shoulder is against cable jacket. Braid will flare out against body shoulder.

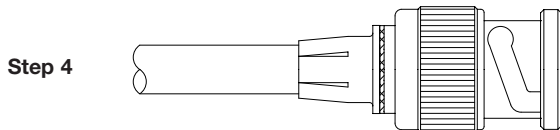

**Step 4** Grasp cable with hand and push ferrule over barb until braid is captured between ferrule and body flange. Assembly is complete.

## CRIMP TERMINATION FOR TYPE 1 – 75Ω CONNECTORS

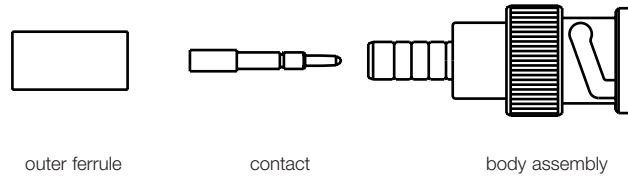

Amphenol Number	Connector Type	Cable RG-/U	Hex Crimp Data			Stripping Dimensions, inches (mm)		
			Cavity for Contact	Cavity for Outer Ferrule	CTL Series Tool No.	a	b	c
31-70000	75Ω BNC Plug	6, Belden 9248, Plenum 6	.052(1.3) sq.	.324(8.2)	CTL-8	.577(14.7)	.234(5.9)	.140(3.6)
31-70000-1000	75Ω BNC Plug	6, Belden 9248	.052(1.3) sq.	.324(8.2)	CTL-8	.577(14.7)	.234(5.9)	.140(3.6)
31-70008	75Ω BNC Plug	59	.052(1.3) sq.	.255(6.5)	CTL-6 or 8	.577(14.7)	.234(5.9)	.140(3.6)
31-70008-1000	75Ω BNC Plug	59 (20GA CC)	.052(1.3) sq.	.255(6.5)	CTL-6 or 8	.577(14.7)	.234(5.9)	.140(3.6)
31-70008-3000	75Ω BNC Plug	59 (.032 CC)	.052(1.3) sq.	.255(6.5)	CTL-6 or 8	.577(14.7)	.234(5.9)	.140(3.6)
31-70009	75Ω BNC Jack	59	.052(1.3) sq.	.255(6.5)	CTL-6 or 8	.557(14.1)	.214(5.4)	.156(4.0)
31-70013	75Ω BNC Plug	179, 187	.052(1.3) sq.	.178(4.5)	CTL-6	.577(14.7)	.234(5.9)	.140(3.6)
31-70013-1000	75Ω BNC Plug	DbI. Br. 179, ATT19224-L2	.052(1.3) sq.	.178(4.5)	CTL-6	.594(15.1)	.250(6.4)	.156(4.0)
31-70015-1000	75Ω BNC Angle Plug	DbI. Br. 179, ATT19224-L2	.052(1.3) sq.	.178(4.5)	CTL-6	.649(16.5)	.435(11.0)	.125(3.2)
31-70016	75Ω BNC Jack	179, 187	.052(1.3) sq.	.178(4.5)	CTL-6	.886(22.5)	.451(11.4)	.140(3.6)
31-70016-1000	75Ω BNC BulkH. Jack	DbI. Br. 179, ATT19224-L2	.052(1.3) sq.	.178(4.5)	CTL-6	.886(22.5)	.451(11.4)	.140(3.6)
31-70022	75Ω BNC Plug	ATT 728B, Belden 9231	.068(1.7)hex	.324(8.2)	CTL-8	.579(15.1)	.125(3.2)	.125(3.2)
31-70082	75Ω BNC Angle Plug	ATT 735A	Solder Only	.160(4.1)	▲	.635(16.1)	.385(9.8)	.200(5.1)
31-70222	75Ω BNC Plug	Belden 8281, 9231	.052(1.3) sq.	.324(8.2)	CTL- 8	.577(14.7)	.234(5.9)	.140(3.6)

### Step 1

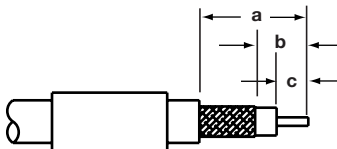

▲ For RG-174, 179, 187, 188, 316/U cables only, slit jacket back .100"(2.5mm) as shown. Before attaching center contact, slide TFE sleeve (not shown) over cable dielectric and under braid. The center contact should butt against the dielectric and TFE sleeve.

**Step 1** Slide outer ferrule over cables shown. Flare slightly end of cable braid as shown to facilitate insertion of inner ferrule. **IMPORTANT:** Do not comb out braid.

### Step 2

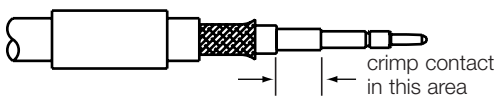

**Step 2** Place contact onto center conductor so it butts against cable dielectric. Crimp contact in place.

### Step 3

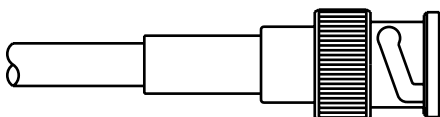

**Step 3** Install cable assembly into body assembly so inner ferrule slides over sleeve and under braid. Push cable assembly forward until contact seats in insulator. Slide outer ferrule over braid and up against connector body. Crimp outer ferrule.

▲ use die set 227-1448 with tool frame 227-944

## CRIMP TERMINATION FOR TYPE 2 – 75Ω CONNECTORS

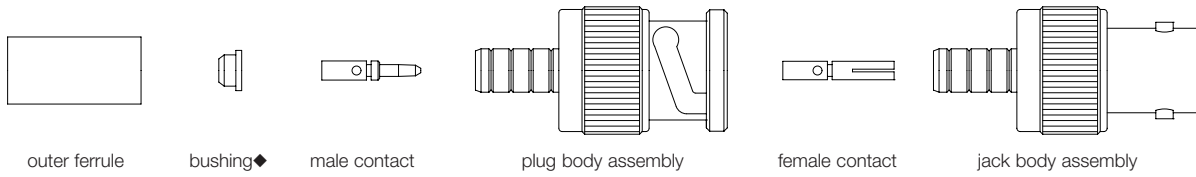

◆ for use on RG-62, 71, 210 cable only

Amphenol Number	Connector Type	Cable RG-/U	Hex Crimp Data				Stripping Dimensions, inches (mm)		
			Cavity for Contact	Cavity for Outer Ferrule	Die Set for Tool 227-944*	CTL Series Tool No.	a	b	c
31-71000-RFX	75Ω BNC Plug	6	.068(1.7)	.324(8.2)	227-1221-32	CTL-2	.593(15.1)	.250(6.4)	.156(4.0)
31-71008	75Ω BNC Plug	59, 62	.068(1.7)	.255(6.5)	227-1221-13	CTL-1	.593(15.1)	.250(6.4)	.156(4.0)
31-71008-RFX	75Ω BNC Plug	59, 62	.068(1.7)	.255(6.5)	227-1221-13	CTL-1	.630(16.0)	.303(7.7)	.156(4.0)
31-71008-1RFX	75Ω BNC Plug	59 (20GA CC)	.068(1.7)	.255(6.5)	227-1221-13	CTL-1	.630(16.0)	.303(7.7)	.156(4.0)
31-71008-1000	75Ω BNC Plug	59, 62 (20GA CC)	.068(1.7)	.255(6.5)	227-1221-13	CTL-1	.593(15.1)	.250(6.4)	.156(4.0)
31-71008-2000	75Ω BNC Plug	Plenum -59, B89269	.068(1.7)	.255(6.5)	227-1221-13	CTL-1	.593(15.1)	.250(6.4)	.156(4.0)
31-71010	75Ω BNC Angle Plug	59, 62	.068(1.7)	.255(6.5)	227-1221-13	CTL-1	.578(14.7)	.328(8.3)	.125(3.2)
31-71010-RFX	75Ω BNC Plug	59	.068(1.7)	.255(6.5)	227-1221-13	CTL-1	.677(17.2)	.350(9.0)	.156(4.0)
	75Ω BNC Plug	62	.068(1.7)	.255(6.5)	227-1221-13	CTL-1	.677(17.2)	.350(9.0)	.197(5.0)
31-71011	75Ω BNC Bulk. Jack	59, 62	.068(1.7)	.255(6.5)	227-1221-13	CTL-1	.593(15.1)	.250(6.4)	.156(4.0)
31-71011-RFX	75Ω BNC Bulk. Jack	59, 62	.068(1.7)	.255(6.5)	227-1221-13	CTL-1	.689(17.5)	.362(9.2)	.157(4.0)
31-71013	75Ω BNC Plug	179, 187	.068(1.7)	.178(4.5)	227-1221-9	CTL-2	.539(15.1)	.250(6.4)	.156(4.0)
31-71013-RFX	75Ω BNC Plug	179, 187	.068(1.7)	.178(4.5)	227-1221-9	CTL-2	.590(15.0)	.323(8.2)	.118(3.0)
31-71013-1000	75Ω BNC Plug	Dbl. Br. RG-179	.068(1.7)	.178(4.5)	227-1221-9	CTL-2	.593(15.1)	.250(6.4)	.156(4.0)
31-71014-RFX	75Ω BNC Jack	179, 187	.068(1.7)	.178(4.5)	227-1221-9	CTL-2	.571(14.5)	.303(7.7)	.157(4.0)
31-71016	75Ω BNC Bulk. Jack	179, 187	.068(1.7)	.178(4.5)	227-1221-9	CTL-2	.593(15.1)	.250(6.4)	.156(4.0)
31-71016-RFX	75Ω BNC Bulk. Jack	179, 187	.068(1.7)	.178(4.5)	227-1221-9	CTL-2	.630(16.0)	.362(9.2)	.157(4.0)
31-71032	75Ω BNC Plug	B8281, 88281	.068(1.7)	.324(8.2)	227-1221-32	CTL-2	.593(15.1)	.250(6.4)	.156(4.0)
31-71033	75Ω BNC Plug	B8218	.068(1.7)	.178(4.5)	227-1221-9	CTL-2	.593(15.1)	.250(6.4)	.156(4.0)
31-71034	75Ω BNC Plug	Belden 89292	.100(2.5)	.429(10.9)	227-1221-25	CTL-3	.593(16.7)	.250(6.4)	.156(4.0)
31-71035	75Ω BNC Plug	PL-59 (20GA CC)	.068(1.7)	.255(6.5)	227-1221-13	CTL-1	.593(15.1)	.250(6.4)	.156(4.0)
31-71064	75Ω BNC Plug	Belden 9248, PI-6	.068(1.7)	.324(8.2)	227-1221-32	CTL-2	.593(15.1)	.250(6.4)	.156(4.0)
31-71065	75Ω BNC Plug	Belden 9290	.068(1.7)	.324(8.2)	227-1221-32	CTL-2	.593(15.1)	.250(6.4)	.156(4.0)
31-71066	75Ω BNC Plug	Quad Shield 59	.068(1.7)	.263(6.7)	227-1221-15	—	.593(15.1)	.250(6.4)	.156(4.0)

### Step 1

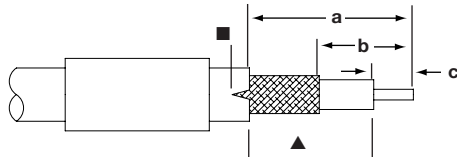

■▲ For RG-174, 179, 187, 188, 316/U cables only, slit jacket back .100" (2.5mm) as shown. Before attaching center contact TFE sleeve (not shown) over cable dielectric and under braid. For 31-71016, before attaching center contact. Slide metal spacer/TFE sleeve (not shown) over cable dielectric and under braid. The center contact should butt against the dielectric and TFE sleeve.

### Step 2

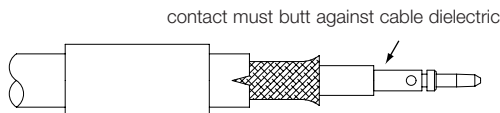

### Step 3

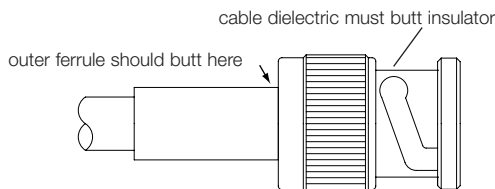

### Step 1

Strip cable jacket, braid, and dielectric to dimensions in table above. [for RG-62,71,210/U cable, trim an additional .039" (1.0mm) of insulation off center conductor and add bushing] All cuts are to be sharp and square. Important: Do not nick braid, dielectric, and center conductor. Slide outer ferrule onto cable as shown.

### Step 2

Flare slightly end of cable braid as shown to facilitate insertion of inner ferrule. Important: Do not comb out braid. Place contact on cable center conductor so that it butts against cable dielectric. Crimp contact in place using Die Set Cavity indicated in table above. When using RG-62, 71, 210, install bushing over center conductor before installing contact.

### Step 3

Install cable assembly into body assembly so that inner ferrule portion slides under braid. Push cable assembly forward until contact snaps into place in insulator. Slide outer ferrule over braid and up against connector body. Crimp outer ferrule using Die Set Cavity specified in table above.

\* for pneumatic crimp tool 227-60, use die sets indicated in this column

### CLAMP PLUGS

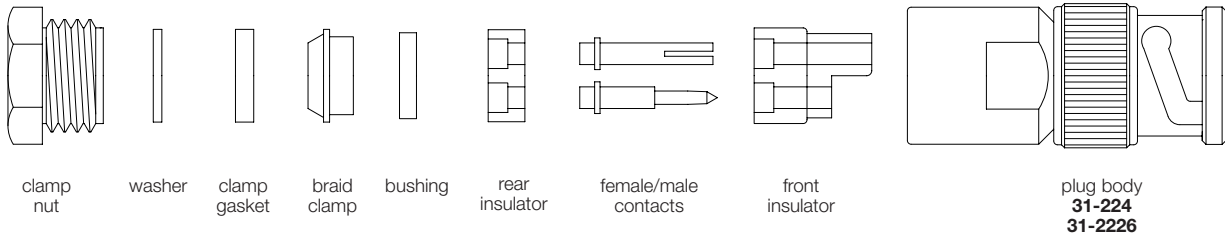

**Step 1**

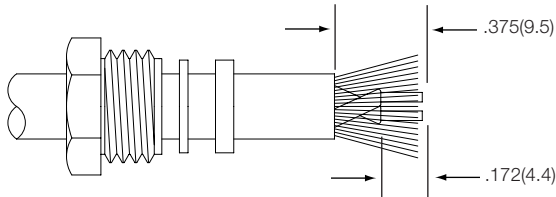

**Step 1** Cut end of cable sharp and square. Slide clamp nut, washer and clamp gasket over jacket. Strip jacket to dimension shown. Comb out braid and fold out. Bare conductors to dimension shown.

**Step 2**

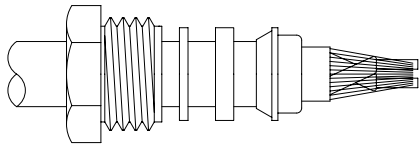

**Step 2** Pull braid forward and taper toward conductors. Slide braid clamp over braid as shown and push against cable jacket.

**Step 3**

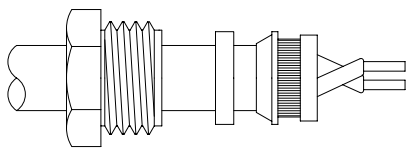

**Step 3** Fold back braid, trim to proper length so no braid strands extend beyond shoulder of braid clamp and evenly form over braid clamp as shown. Slide on bushing. Tin center conductors using minimum amount of heat.

**Step 4**

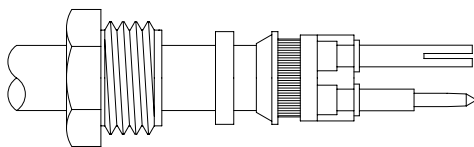

**Step 4** Bend connectors out as necessary for alignment and slide on rear insulator. Solder contacts. Remove any excess solder from contact O.D.

**Step 5**

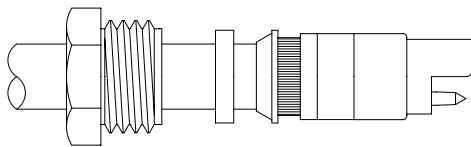

**Step 5** Slide front insulator over contacts and butt against contact shoulders as shown.

**Step 6**

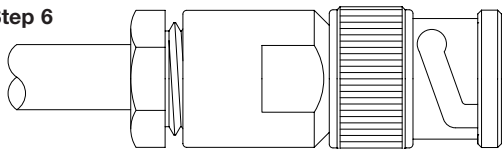

**Step 6** Insert prepared cable termination into connector body. Make sure sharp edge of braid clamp seats properly in V-groove clamp gasket. Tighten securely, turning nut only. Do not twist connector body.

## CLAMP TYPES

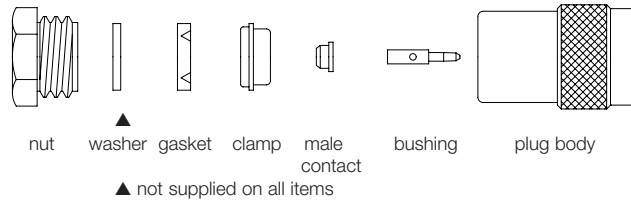

Amphenol Number	Conn. Type	Cable	Stripping Dimensions, In.(mm)	
			a	c
79075	TNC Angle Plug	RG-58	.281(7.1)	.109(2.8)
79875	TNC Plug	RG-58	.281(7.1)	.109(2.8)
79600	TNC Jack	RG-58	.300(7.5)	.110(2.8)

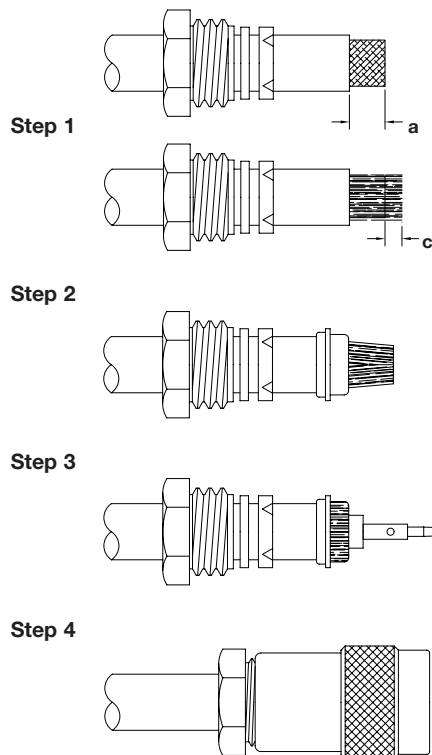

**Step 1** Place nut, washer (when supplied) and gasket over cable and strip jacket to dimension **a** shown in table above.

**Step 2** Comb out braid and fold out. Trim insulation off center conductor to dimension **c** shown in table above. Tin center conductor. Pull braid wires forward and taper toward center conductor. Place clamp over braid and push back against cable jacket.

**Step 3** Fold back braid wires as shown, trim to proper length [.125" (3.2mm)] and form over clamp as shown. Solder contact to center conductor.

**Step 4** Insert cable and parts into connector body. Make sure sharp edge of clamp seats properly in gasket. Tighten nut.

## CRIMP-CRIMP TYPES



outer ferrule    bushing    male contact    plug body assembly  
 ♦ This part is used only with RG-62 cable

Amphenol Number	Connector Type	Cable RG-/U	Hex Crimp Data				Stripping Dimensions, inches (mm)		
			Cavity for Contact	Cavity for Outer Ferrule	Die Set for Tool 227-944	CTL Series Tool No.	a	b	c
36825	TNC Plug	58, 141	.068(1.7)	.213(5.4)	227-1221-11	CTL-1	.593(15.1)	.250(6.4)	.156(4.0)
31-2318	TNC Bulk. Jack	174, 188, 316	.068(1.7)	.178(4.5)	227-1221-09	CTL-2	.593(15.1)	.250(6.4)	.156(4.0)
31-2367	TNC Plug	58, 141	.068(1.7)	.213(5.4)	227-1221-11	CTL-1	.593(15.1)	.250(6.4)	.156(4.0)
31-2367-RFX	TNC Plug	58, 141, 142A	.068(1.7)	.213(5.4)	227-1221-11	CTL-1	.630(16.0)	.303(7.7)	.156(4.0)
31-2368	TNC Plug	59, 62	.068(1.7)	.255(6.5)	227-1221-13	CTL-1	.593(15.1)	.250(6.4)	.156(4.0)
31-2373	TNC Plug	55, 142, 223	.068(1.7)	.213(5.4)	227-1221-11	CTL-1	.593(15.1)	.250(6.4)	.156(4.0)
31-2381	TNC Angle Plug	55, 142, 223, 400	.068(1.7)	.213(5.4)	227-1221-11	CTL-1	.578(14.7)	.328(8.3)	.125(3.2)
31-4452	TNC Plug	142, 400	.068(1.7)	.213(5.4)	227-1221-11	CTL-1	.593(15.1)	.250(6.4)	.156(4.0)
31-2242	TNC Plug	179,187	.068 (1.7)	.178 (4.5)	227-1221-09	CTL-2	.593(15.1)	.250(6.4)	.156(4.0)
31-2242-RFX	TNC Plug	179,187	.068 (1.7)	.178 (4.5)	227-1221-09	CTL-2	.590(15.0)	.323(8.2)	.118(3.0)
31-2264	TNC Blkh Jack	59,62,140,210	.068 (1.7)	.255 (8.5)	227-1221-13	CTL-1	.593(15.1)	.250(6.4)	.156(4.0)
31-2264-RFX	TNC Blkh Jack	59	.068 (1.7)	.255 (8.5)	227-1331-13	CTL-1	.689(17.5)	.362(9.2)	.157(4.0)
31-2264-RFX	TNC Blkh Jack	62	.068 (1.7)	.255 (8.5)	227-1331-13	CTL-1	.689(17.5)	.362(9.2)	.197(5.0)
31-2315	TNC Plug	174,188	.068 (1.7)	.178 (4.5)	227-1221-09	CTL-2	.593(15.1)	.250(6.4)	.156(4.0)
31-2315-RFX	TNC Plug	174,188,316	.068 (1.7)	.178 (4.5)	227-1221-09	CTL-2	.590(15.0)	.323(8.2)	.118(3.0)
31-2317	TNC Jack	174,188	.068 (1.7)	.178 (4.5)	227-1221-09	CTL-2	.590(15.0)	.323(8.2)	.118(3.0)
31-2318	TNC Blkh Jack	174,187,188	.068 (1.7)	.178 (4.5)	227-1221-09	CTL-2	.590(15.0)	.323(8.2)	.118(3.0)
31-2368-RFX	TNC Plug	59	.068 (1.7)	.255 (8.5)	227-1221-13	CTL-1	.630(16.0)	.303(7.7)	.157(4.0)
31-2368-RFX	TNC Plug	62	.068 (1.7)	.255 (8.5)	227-1221-13	CTL-1	.630(16.0)	.303(7.7)	.197(5.0)
31-2381	TNC Angle Plug	55,142	.068 (1.7)	.213 (5.4)	227-1221-11	CTL-1	.578(14.7)	.328(8.3)	.125(3.2)
31-2382	TNC Angle Plug	58,141	.068 (1.7)	.213 (5.4)	227-1221-11	CTL-1	.578(14.7)	.328(8.3)	.125(3.2)
31-2383	TNC Angle Plug	62	.068 (1.7)	.255 (8.5)	227-1221-13	CTL-1	.689(17.5)	.362(9.2)	.156(4.0)
31-2389	TNC Blkh Jack	58,141	.068 (1.7)	.213 (5.4)	227-1221-11	CTL-1	.593(15.1)	.250(6.4)	.156(4.0)
31-2389-RFX	TNC Blkh Jack	141,142	.068 (1.7)	.213 (5.4)	227-1221-11	CTL-1	.689(17.5)	.362(9.2)	.157(4.0)
31-2367-RFX	TNC Plug	58,141	.068	.213	227-1221-11	CTL-1,5	.630 (16.0)	.303 (7.7)	.157 (4.0)
31-5849-RFX	TNC Angle Plug	58,58c	Solder	.213	227-1221-11	CTL-1,3,5	.709(18)	.382(9.7)	.161(4.1)
31-6000-RFX	TNC Plug	8x,LMR240	.068	.255	227-1221-13	CTL-1,5	.630 (16)	.303 (7.7)	.157 (4.0)
31-6001-RFX	TNC Plug	B8214, B9913	Solder	.429	227-1221-25	CTL-4	.630 (16)	.303 (7.7)	.157 (4.0)
31-6002-RFX	TNC Angle Plug	LMR 400, B9913,B9914	Solder	.429	227-1221-25	CTL-4	.728 (18.5)	.401 (0.2)	.244 (6.2)
31-6003-RFX	TNC Angle Plug	8x,LMR240	Solder	.255	227-1221-13	CTL-1,5	.728 (18.5)	.401 (10.2)	.244 (6.2)

### Step 1

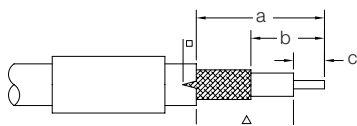

■ ▲ For RG-174, 179, 187, 188, 316/U cables only, slit jacket back .100"(2.5mm) as shown. Before attaching center contact, slide metal spacer/TFE sleeve (not shown) over cable dielectric. The center contact should butt against the dielectric and TFE sleeve.

### Step 1

Strip cable jacket, braid, and dielectric to dimensions in table above. All cuts are to be sharp and square. Important: Do not nick braid, dielectric, and center conductor. Slide outer ferrule onto cable as shown.

### Step 2

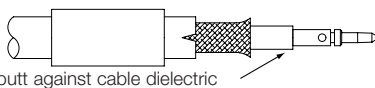

contact must butt against cable dielectric

### Step 2

Flare slightly end of cable braid as shown to facilitate insertion of inner ferrule. Important: Do not comb out braid. Place contact on cable center conductor so that it butts against cable dielectric. Crimp contact in place using Die Set Cavity indicated in table above.

### Step 3

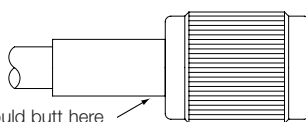

outer ferrule should butt here

cable dielectric must butt insulator

### Step 3

Install cable assembly into body assembly so that inner ferrule portion slides under braid. Push cable assembly forward until contact snaps into place in insulator. Slide outer ferrule over braid and up against connector body. Crimp outer ferrule using Die Set Cavity in table above.



## QUICKTRIM® PLUG

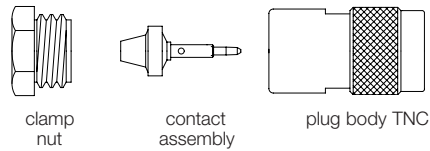

Amphenol Number	Cable RG-/U	Center Contact Affixment		
		Hex Size	Die Set for Tool 227-944	CTL Series Tool Number
31-5061	59, 59A, 62, 62A	.068(1.7)	227-1221-13 Cavity B	CTL-1

### Step 1A

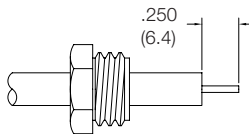

**Step 1A** For all cables listed, except Plenum 62. Slide clamp nut over cable. Strip cable to dimension shown. Cut braid and dielectric square. Do not nick center conductor.

### Step 1B

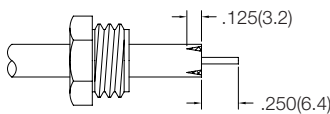

**Step 1B** For Plenum 62 (IBM 4885584). Same as step 1A, and then slit jacket back .125"(3.2 mm) in four places 90° apart as shown in illustration.

### Step 2

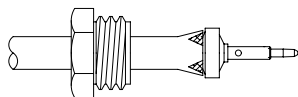

**Step 2** Slide contact assembly under braid and jacket until braid butts as shown. Use caution that braid slides over contact assembly and not inside of it. Be sure center conductor is visible through side hole of contact. Crimp contact to conductor using Amphenol CTL-1 crimp tool; or by using die set 227-1221-13 cavity B in tool frame 227-944.

### Step 3

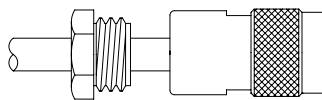

**Step 3** Insert into connector body.

### Step 4

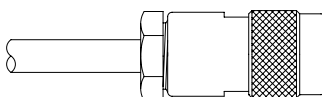

**Step 4** Tighten clamp nut to a torque of 35 lbf-in.

### Crimp Types

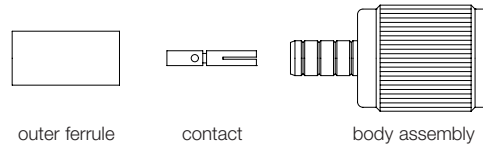

Amphenol Number	Connector Type	Cable RG-/U	Hex Crimp Data				Stripping Dimensions, inches (mm)		
			Cavity for Contact	Cavity for Outer Ferrule	Die Set for Tool 227-944	CTL Series Tool No.	a	b	c
31-5677	RP-TNC Plug w/ socket contact	58	.068(1.7)	.213(5.4)	227-1221-11	CTL-1	.593(15.1)	.250(6.4)	.156(4.0)
31-5677-1000	RP-TNC Plug w/ socket contact	142	.068(1.7)	.213(5.4)	227-1221-11	CTL-1	.593(15.1)	.250(6.4)	.156(4.0)
31-5678	RP-TNC Jack w/ pin contact	58	.068(1.7)	.213(5.4)	227-1221-11	CTL-1	.593(15.1)	.250(6.4)	.156(4.0)
31-5679	RP-TNC Plug w/ socket contact	Belden 9913	.116(2.9)	.429(10.9)	227-1221-61	—	.688(17.5)	cut for b & c	.188(4.8)
31-5680	RP-TNC Ang. Plug w/ socket contact	Belden 9913	.116(2.9)	.429(10.9)	227-1221-61	—	.812(20.6)	.376(9.6)	.188(4.8)
31-5684	RP-TNC Jack w/ pin contact	Belden 9913	.116(2.9)	.429(10.9)	227-1221-61	—	.688(17.5)	cut for b & c	.188(4.8)
31-5685	RP-TNC Panel Jack w/ pin contact	178	.068(1.7)	.151(3.8)	227-1221-62	—	.531(13.5)	cut for b & c	.156(4.0)
31-5686	RP-TNC Blkh. Jack w/ pin contact	178	.068(1.7)	.151(3.8)	227-1221-62	—	.812(20.6)	.437(11.1)	.156(4.0)
31-5687	RP-TNC Blkh. Jack w/ pin contact	58, 141	.068(1.7)	.213(5.4)	227-1221-11	CTL-1	.812(20.6)	.469(11.9)	.156(4.0)
31-5705	RP-BNC Plug w/ socket contact	58, 141	.068(1.7)	.213(5.4)	227-1221-11	CTL-1	.593(15.1)	.250(6.4)	.156(4.0)
31-5787	RP-BNC Blkh. Jack w/ pin contact	174, 188, 316	.068(1.7)	.178(4.5)	227-1221-9	CTL-2	.670(17.0)	.500(12.7)	.220(5.6)
31-6034	BNC RP Plug	B8214,9913	.118 (3.0)	.429 (10.9)	227-1221-61	CTL-11	.639 (16.2)	.312 (7.9)	.158 (4.0)
31-6036	BNC RP Plug	58	.068 (1.7)	.213 (5.4)	227-1221-11	CTL-1,5	.639 (16.2)	.312 (7.9)	.158 (4.0)
31-6031	TNC RP Jack	58	.068 (1.7)	.213 (5.4)	227-1221-11	CTL-1,5	.630 (16.0)	.303 (7.7)	.157 (4.0)
31-6035	BNC RP Jack	58	.068 (1.7)	.213 (5.4)	227-1221-11	CTL-1,5	.630 (16.0)	.303 (7.7)	.157 (4.0)
31-6032	TNC RP Blkh Jack	58	.068 (1.7)	.213 (5.4)	227-1221-11	CTL-1,5	.689 (17.5)	.362 (9.2)	.158 (4.0)
31-6030	TNC RP Plug	58	.068 (1.7)	.213 (5.4)	227-1221-11	CTL-1,5	.639 (16.2)	.312 (7.9)	.158 (4.0)
31-6033	TNC RP Plug	B8214,9913	.118 (3.0)	.429 (10.9)	227-1221-61	CTL-11	.639 (16.2)	.312 (7.9)	.158 (4.0)

#### Step 1

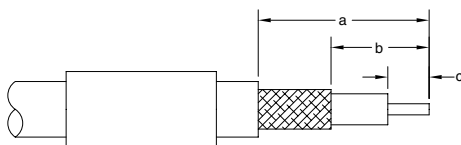

#### Step 1a

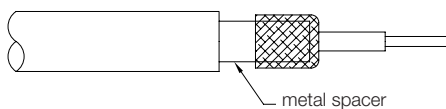

#### Step 2

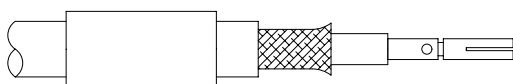

#### Step 3

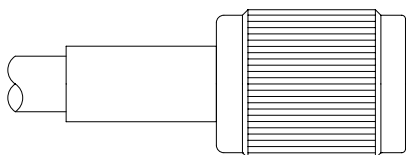

**Step 1** Strip cable jacket, braid, and dielectric to dimensions in table above. All cuts are to be sharp and square. Important: Do not nick braid, dielectric, and center conductor. Slide outer ferrule onto cable as shown.

**Step 1a** For **31-5685** & **31-5686** only, slide metal spacer over exposed braid until it butts against cable jacket. Fold braid back over spacer, making sure to smooth out braid over spacer. Slide TFE sleeve over end of cable dielectric, positioning it flush with end of dielectric.

**Step 2** For all P/Ns place contact on cable center conductor so that it butts against cable dielectric. Crimp contact in place using Die Set Cavity in table above. For all P/Ns except 31-5685 & 31-5686, flare slightly end of cable braid as shown to facilitate insertion of inner ferrule. Important: Do not comb out braid.

**Step 3** For all P/Ns except 31-5685 & 31-5686, install cable assembly into body assembly so that ferrule on body slides under braid. Push cable assembly forward until contact snaps into place in insulator. Slide crimp ferrule over braid and up against connector body. Crimp outer ferrule using Die Set Cavity in table above.

**Step 3a** For **31-5685** & **31-5686**, slide cable assembly into body until it clicks into place. Crimp on the end of the body using Die Set cavity in table above.

### CRIMP-CRIMP TYPE

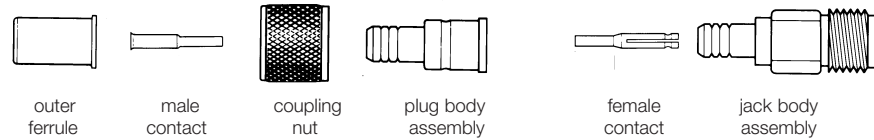

Number	Connector Type	Cable RG-/U	Amphenol inches (mm)			Strip Dimensions, Crimp Data			
			a	b	c	Cavity for Contact	Cavity for Outer Ferrule	Die Set for Tool 227-944	CTL Series Tool Number
<b>81-114-RFX</b>	Mini-UHF Plug	B 9258	.629(16.0)	.302(7.7)	.157(4.0)	.068(1.7)	.255(6.5)	227-1221-13	CTL-1, -5, -6
<b>81-115BK-1000</b>	Mini-UHF Plug	58	.593(15.1)	.218(5.5)	.218(5.5)	.052(1.3) Sq.	.213(5.4)	227-1409	CTL-5
<b>81-115N-1000</b>	Mini-UHF Plug	58	.593(15.1)	.218(5.5)	.218(5.5)	.052(1.3) Sq.	.213(5.4)	227-1409	CTL-5
<b>81-116</b>	Mini-UHF Jack	58	.500(12.7)	.219(5.5)	.219(5.5)	.052(1.3) Sq.	.213(5.4)	227-1409	CTL-5
<b>81-182-RFX</b>	Mini-UHF Jack	59	.625(15.9)	.299(7.6)	.236(6)	.068(1.7) Sq.	.255(6.5)	227-1221-13	CTL-1, -5, -6
<b>81-183-RFX</b>	Mini-UHF Jack	58/u58b/u	.661(16.8)	.334(8.5)	.118(3)	.068(1.7) Sq.	.213(5.4)	227-1221-11	CTL-1, -5, -6
<b>81-181-RFX</b>	Mini-UHF Plug	59	.937(23.8)	.610(15.5)	.492(12.5)	.068(1.7)	.255(6.5)	227-1221-13	CTL-1, -5, -6
<b>81-196-RFX</b>	Mini-UHF Plug	58C, 58	.937(23.8)	.610(15.5)	.492(12.5)	.068(1.7)	.213(5.4)	227-1221-11	CTL-1, -5, -6

**Step 1**

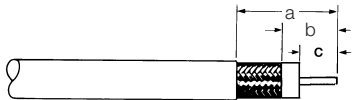

**Step 1** Strip cable to dimensions shown in table. All cuts are to be sharp and square. **Important:** do not nick braid, dielectric, or center conductor.

**Step 2**

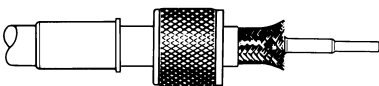

**Step 2** Slide outer ferrule onto cable as shown. (For straight plugs, slide coupling nut onto cable, keeping the open end of the nut toward the stripped end of the cable.) Flare slightly end of cable braid as shown to facilitate insertion of inner ferrule. **Important:** Do not comb out braid. Place contact on cable center conductor so it butts against cable dielectric. Crimp contact in place using Tool Handle and Die Set Cavity shown in table above or soft solder per QQ-S-571 comp. Sn60.

**Step 3**

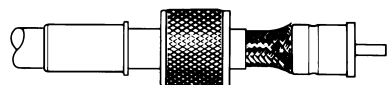

**Step 3** Install cable assembly into body assembly so inner ferrule portion slides under braid. Push cable assembly forward until cable dielectric seats against connector insulator.

**Step 4**

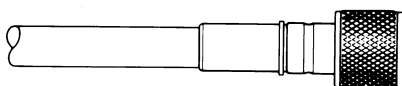

**Step 4** (For straight plugs, slide coupling nut forward over body assembly as shown.) Slide outer ferrule over braid and up against connector body, holding connector body firmly in place. Crimp outer ferrule using Tool Handle and Die Set Cavity shown in table above.

## CLAMP TYPE FOR FLEXIBLE CABLES

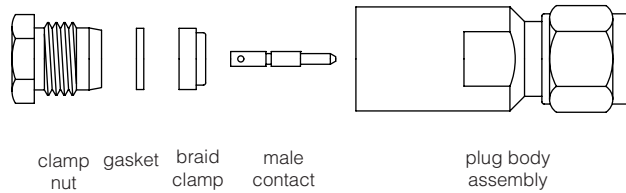

Amphenol Number	Connector Type	Cable RG-/U	Stripping Dimensions, inches (mm)		
			a	b	c
901-103	SMA Plug	55, 58, 141, 142, 223	.265(7)	.140(3.5)	.094(2.5)

### Step 1

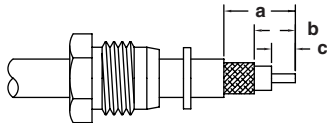

**Step 1** Place nut and gasket over cable. Strip cable to dimensions shown in cable. Comb out braid.

### Step 2

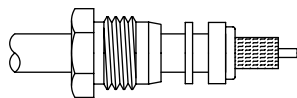

**Step 2** Place braid clamp over braid and push back against cable jacket. Fold back wires, trim as necessary so that wires do not touch shoulder of clamp. Cuts must be square. Do not nick center conductor.

### Step 3

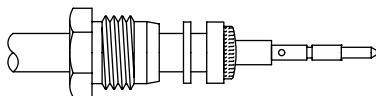

**Step 3** Solder center contact to cable (SN60-40 rosin core solder recommended). Center contact must seat square against dielectric. Avoid excessive heat which may distort dielectric.

### Step 4

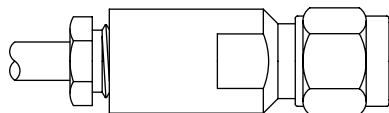

**Step 4** Thread connector assembly onto prepared cable assembly. Tighten to 20-25 in/lbs torque.

## MODIFIED CLAMP TYPE FOR FLEXIBLE CABLES

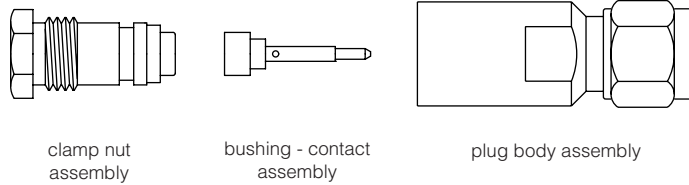

clamp nut assembly

bushing - contact assembly

plug body assembly

Amphenol Number	Connector Type	Cable RG-/U	Stripping Dimensions, inches (mm)		
			a	b	c
901-128-11	SMA Plug	174, 316	.328(14)	—	.125(3.2)

Step 1

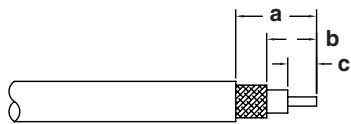

**Step 1** Strip cable to dimensions shown in table. Cut must be square. Do not nick center conductor. Comb out braid.

Step 2

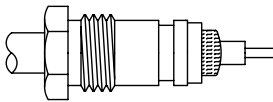

**Step 2** Place clamp assembly over braid and push back against cable jacket. Fold back braid wires, trim as necessary so that wires do not touch shoulder of gasket.

Step 3

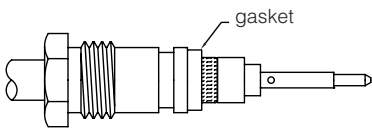

**Step 3** (For angle connectors, skip to next step.) Assemble bushing assembly and solder center contact to cable (SN60-40 rosin core solder recommended.)

Step 4

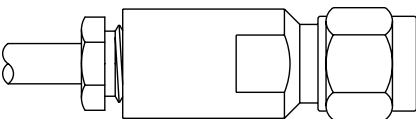

**Step 4** Thread connector assembly onto prepared cable assembly. Tighten to 20-25 in/lbs torque. For angle connectors, solder center conductor and cap in place.

## SOLDER TYPE FOR FLEXIBLE CABLES

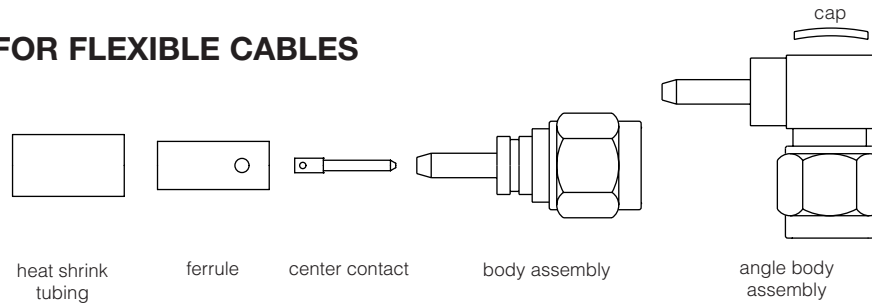

Amphenol Number	Connector Type	Cable RG-/U	Stripping Dimensions, inches (mm)		
			a	b	c
901-9501-3	SMA Plug	174, 179, 187, 188, 316	.440(11.2)	.130(3.3)	.090(2.3)
901-9521-3	SMA Angle Plug	174, 179, 187, 188, 316	.437(11.1)	.197(5.0)	.090(2.3)

### Step 1

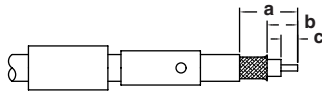

### Straight connectors:

### Step 2

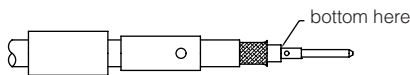

### Step 3

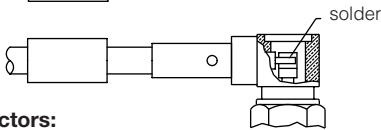

### Angle connectors:

### Step 2

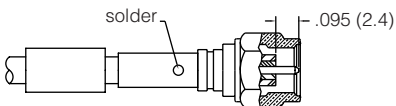

### Step 3

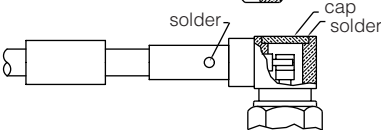

**Step 1** Slide shrink tubing and ferrule up on cable as shown. Strip cable to dimensions shown in table. Flare cable braid.

### Straight connectors:

**Step 2** Solder center contact to cable center conductor as shown. Remove excess solder.

**Note:** Contact must bottom against cable dielectric.

**Step 3** Install coupling nut and body assembly as shown. Press ferrule against body and solder. Place heat shrink tubing over body and apply heat.

### Angle connectors:

**Step 2** Place cable dielectric into body and press ferrule against body as shown. Solder center conductor to contact as shown.

**Step 3** Bottom ferrule against body and solder as shown. Place cap into position and also solder as shown. Place heat shrink tubing over body and apply heat.

## SOLDER TO BODY/PRESSFIT INSULATOR FOR SEMI-RIGID CABLE

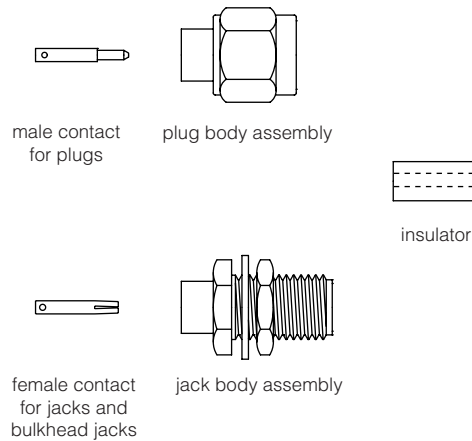

Amphenol Number	Connector Type	Cable S/R	Dim a
<a href="#">901-9201-2A</a>	SMA Plug	.085(2.2)	.125(3.2)
<a href="#">901-9201-2ASF</a>	SMA Plug	.085(2.2)	.125(3.2)
<a href="#">901-9202-1A</a>	SMA Jack	.141(3.6)	.125(3.2)
<a href="#">901-9202-2A</a>	SMA Jack	.085(2.2)	.125(3.2)
<a href="#">901-9210-1</a>	SMA Bulkhead Jack	.141(3.6)	.125(3.2)
<a href="#">901-9210-2</a>	SMA Bulkhead Jack	.085(2.2)	.125(3.2)
<a href="#">901-9867-RFX</a>	SMA Plug	.085(2.2)	.098(2.5)
<a href="#">901-9868-RFX</a>	SMA Plug	.141(3.6)	.098(2.5)

### Step 1

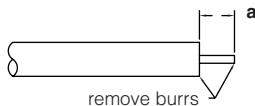

**Step 1** Clean cable end for .625"(16mm) min. length. Trim cable jacket and dielectric to dimension shown. Do not nick center conductor. Remove burrs from jacket and center conductor.

### Step 2

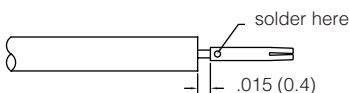

**Step 2** Solder contact to center conductor. Use .015"(4mm) shim to accurately maintain space between jacket, dielectric and contact. Remove all excess solder.

### Step 3a,b

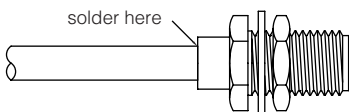

**Step 3a** Assemble cable and contact into connector body. Cable jacket and dielectric to be flush with shoulder of body as shown. Solder cable to connector body. Avoid excessive heat which may distort dielectric.

**Step 3b** Press fit insulator into connector body. Bottom insulator in connector body as shown.

## SOLDER TO BODY/PRE-ASSEMBLED CENTER CONTACT FOR SEMI-RIGID CABLE

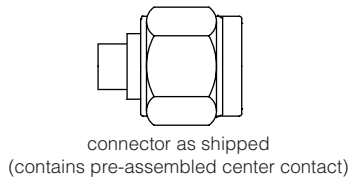

**Step 1**

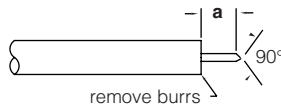

**Step 2**

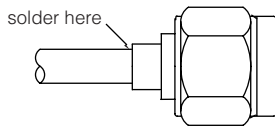

Amphenol Number	Connector Type	Cable S/R	Dim a
901-9723	SMA Plug	.085(2.2)	.125(3.2)
901-9723-10	SMA Plug	.085(2.2)	.125(3.2)
901-9805-HP	SMA Plug	.085(2.2)	.125(3.2)
901-9808	SMA Plug	.141(3.6)	.125(3.2)
901-9808-1	SMA Plug	.141(3.6)	.090(2.3)
901-9808-2	SMA Plug	.141(3.6)	.125(3.2)

**Step 1** Clean cable end for .625"(16mm) min. length. Trim cable jacket and dielectric to dimension shown. Do not nick center conductor. Remove burrs from cable jacket. File blunt end of center conductor to a 90° cone.

**Step 2** Assemble cable into connector body. Make sure center conductor is straight. Use care in pushing center conductor into spring contact. Make sure jacket bottoms in connector. Maintain end pressure while soldering. Avoid excessive heat which may distort dielectric.



## SOLDER TO BODY SMA ANGLE PLUGS

901-9221-1A, -1ASF for .141" S/R; 901-9221-2A, -2ASF for .085" S/R

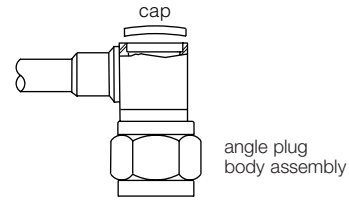

**Step 1**

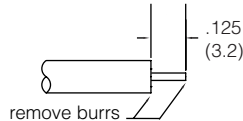

**Step 1**

Clean cable end for .625"(16mm) min. length. Trim cable jacket and dielectric to dimension shown. Do not nick center conductor. Remove burrs from cable jacket and center conductor.

**Step 2**

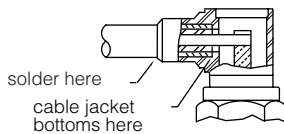

**Step 2**

Assemble cable into connector body. Bottom cable in connector body as shown. Solder cable to connector body as shown.

**Step 3**

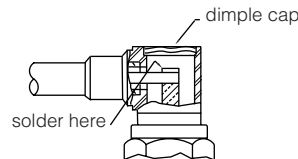

**Step 3**

Solder center conductor to contact as shown. Remove excess solder. Assemble cap and solder or lightly punch center of cap for retention in body.

## C50-SOLDER TO BODY TYPES FOR SEMI-RIGID CABLE WITHOUT CONTACT & INSULATOR

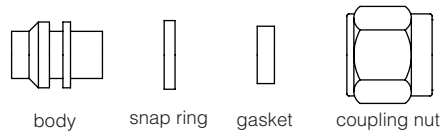

Amphenol Number	Connector Type	Cable RG-/U	Stripping Dims., inches (mm)	
			a	c
901-9201-1A	SMA Plug	.141 RG-402	.091(2.3)	—
901-9201-1ASF	SMA Plug	.141 RG-402	.091(2.3)	—

**Step 1**

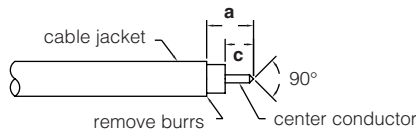

**Step 1**

Clean cable end for .625"(16mm) min. length. Trim cable jacket and dielectric to dimensions shown in table. Do not nick center conductor. Remove burrs from cable jacket. File blunt end of center conductor to a 90° cone.

**Step 2**

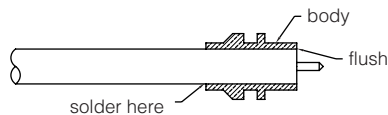

**Step 2**

Assemble cable into connector body. Cable jacket and dielectric to be flush with end of body as shown. Solder cable to connector body. Avoid excessive heat which may distort dielectric.

**Step 3**

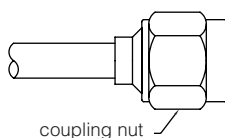

**Step 3**

Assemble snap ring in groove on connector body. Assemble gasket in position as shown. Compress snap ring and assemble coupling nut as shown.

### SOLDER TO COLLET METHOD FOR SEMI-RIGID CABLE

SMA Plug 901-509 for .141S/R

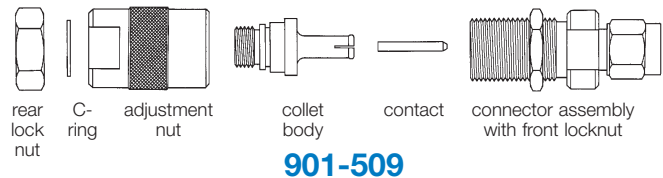
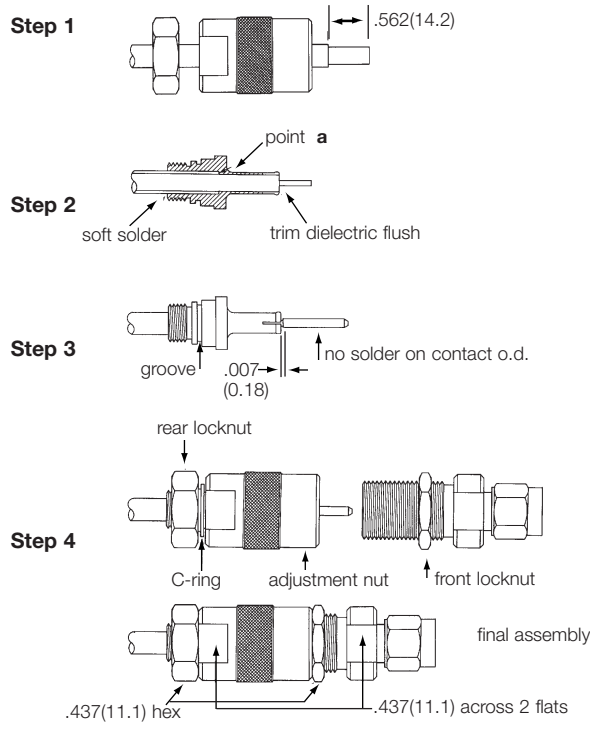

**Step 1** Strip cable jacket to dimensions shown. To avoid cutting into dielectric, score cable jacket and flex slightly to break entirely through jacket. Slide rear locknut and adjustment nut onto cable.

**Step 2** Insert cable into collet body and apply axial pressure to cable to assure good metal contact at Point a. Solder cable jacket to collet body with 60/40 solder. Trim dielectric flush with tines of collet body. Do not nick cable center conductor.

**Step 3** Solder contact to cable center conductor with 60/40 solder and maintain the .007 dimension between contact and tines. Do not permit solder on contact o.d.

**Step 4** Slide adjustment nut over collet body. Install C-ring into groove on collet body. Thread rear locknut loosely into place. Thread this assembly onto connector assembly. Make phase angle adjustment by turning adjustment nut: one revolution of nut =  $[0.636 \times f(\text{GHz})]^\circ$ . When desired phase angle is achieved, hold adjustment nut in place and turn the front locknut down against it. Then tighten rear locknut and assembly is complete.

### CRIMP/SOLDER CENTER CONTACT TYPE FOR FLEXIBLE CABLE

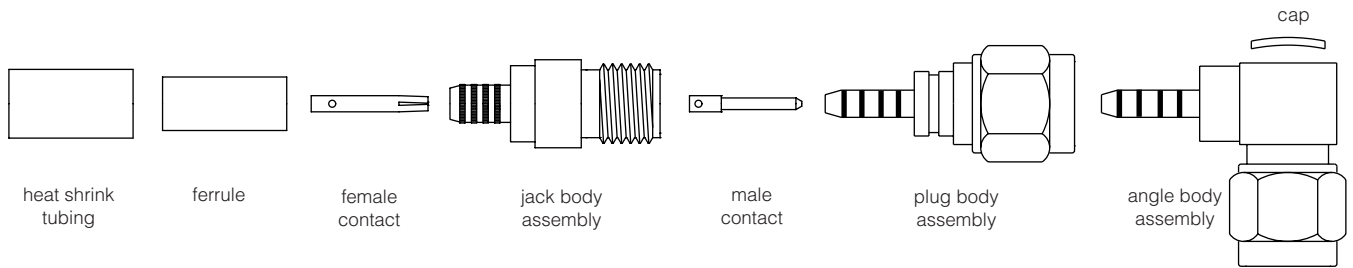

Amphenol Number	Connector Type	Cable RG-U	Stripping Dimensions, inches (mm)			Hex Crimp Data		
			a	b	c	Cavity for Outer Ferrule	Die Set for Tool 227-944	CTL Series Tool
901-9511-1	SMA Plug	55, 142, 223, 400	.300(7.6)	.130(3.3)	.090(2.3)	.213(5.4)	227-1221-11	CTL-1
901-9511-1SF	SMA Plug	55, 142, 223, 400	.300(7.6)	.130(3.3)	.090(2.3)	.213(5.4)	227-1221-11	CTL-1
901-9511-2	SMA Plug	58, 141 B/YR20621	.300(7.6)	.130(3.3)	.090(2.3)	.213(5.4)	227-1221-11	CTL-1
901-9511-2SF	SMA Plug	58, 141 B/YR20621	.300(7.6)	.130(3.3)	.090(2.3)	.213(5.4)	227-1221-11	CTL-1
901-9531-1	SMA Angle Plug	55, 142, 223, 400	.475(12.1)	.235(6.0)	.120(3.0)	.213(5.4)	227-1221-11	CTL-1
901-9531-1SF	SMA Angle Plug	SF 142B	.475(12.1)	.235(6.0)	.120(3.0)	.213(5.4)	227-1221-11	CTL-1
901-9531-2	SMA Angle Plug	58, 141, B/YR20621	.475(12.1)	.235(6.0)	.120(3.0)	.213(5.4)	227-1221-11	CTL-1
901-9531-2SF	SMA Angle Plug	58, 141, B/YR20621	.475(12.1)	.235(6.0)	.120(3.0)	.213(5.4)	227-1221-11	CTL-1
901-9870	SMA Plug	58	.532(13.5)	.205(5.2)	.138(3.5)	.213(5.4)	227-1221-11	CTL-1
901-9871	SMA Plug	223	.532(13.5)	.205(5.2)	.138(3.5)	.213(5.4)	227-1221-11	CTL-1
901-9873	SMA Angle Plug	58	.543(13.8)	.216(5.5)	.102(2.6)	.230(5.9)	227-1221-45	CTL-1
901-9874	SMA Angle Plug	58	.543(13.8)	.216(5.5)	.102(2.6)	.213(5.4)	227-1221-11	CTL-1
901-9875	SMA Bulkhead Jack	174, 179, 187, 188, 316	.394(10.0)	.189(4.8)	.098(2.5)	.128(3.3)	227-1221-03	CTL-13;9
901-9876-RFX	SMA Plug	58	.532(13.5)	.205(5.2)	.138(3.5)	.213(5.4)	227-1221-11	CTL-1
901-9879-RFX	SMA Bulkhead Jack	174, 179, 187, 188, 316	.394(10.0)	.189(4.8)	.098(2.5)	.128(3.3)	227-1221-03	CTL-13;9
901-9880-RFX	SMA Angle Plug	58	.543(13.8)	.216(5.5)	.102(2.6)	.213(5.4)	227-1221-11	CTL-1
901-9902	SMA Angle Plug	223	.475(12.1)	.235(6.0)	.120(3.0)	.213(5.4)	227-1221-11	CTL-1
901-10009-RFX	SMA Plug	LMR 240	.406(10.3)	—	.079(2.0)	.255(6.5)	227-1221-59	CTL-1
901-10010-RFX	SMA Plug	LMR 240	.472(12)	.146(3.7)	.079(2.0)	.213(5.4)	227-1221-11	CTL-1
901-10011	SMA Plug	LMR 240	.618(15.7)	.218(5.54)	.093(2.4)	.255(6.5)	227-1221-59	CTL-1
901-10012	SMA Plug	LMR 200	.293(7.4)	—	.093(2.4)	.213(5.4)	227-1221-11	CTL-1
901-10021-1SF	Jack	55, 142, 223, 400	.415(10.5)	.155(3.9)	.115(2.9)	.213(5.4)	227-1221-11	CTL-1
901-10021-3SF	Jack	174, 188, 316	.415(10.5)	.155(3.9)	.115(2.9)	.128(3.3)	227-1221-03	CTL-13.9
901-10021-12SF	Jack	RD 316	.415(10.5)	.155(3.9)	.115(2.9)	.151(3.8)	227-1221-37	CTL-13.9
901-10024-RFX	Plug	RD 316	.430(10.9)	.170(4.2)	.100(2.5)	.151(3.8)	227-1221-37	CTL-13.9
901-10025-RFX	Plug	RD 316	.430(10.9)	.170(4.2)	.100(2.5)	.151(3.8)	227-1221-37	CTL-13.9
901-10028-RFX	SMA Angle Plug	RD 316	.417(10.6)	.212(5.4)	.106(2.7)	.151(3.8)	227-1221-37	CTL-13.9
901-10029-RFX	SMA Angle Plug	RD 316	.417(10.6)	.212(5.4)	.106(2.7)	.151(3.8)	227-1221-37	CTL-13.9
901-10013-RFX	SMA Angle Plug	174, 188, 316	.382(9.7)	.177(4.5)	.098(2.5)	.128(3.3)	227-1221-03	CTL-13.9
901-9531-3,-3SF	SMA Angle Plug	174, 179, 187, 188, 316	.475(12.1)	.235(6.0)	.090(2.3)	.128(3.3)	227-1221-03 Cavity A	CTL-9
901-9872	SMA Angle Plug	174, 179, 187, 188, 316	.472(12.0)	.216(5.5)	.102(2.6)	.128(3.3)	227-1221-03 Cavity A	CTL-9
901-9877-RFX	SMA Plug	174, 179, 187, 188, 316	.421(10.7)	.165(4.2)	.098(2.5)	.128(3.3)	227-1221-03 Cavity A	CTL-9
901-9916	SMA Plug	174, 179, 187, 188, 316	.421(10.7)	.165(4.2)	.098(2.5)	.128(3.3)	227-1221-03 Cavity A	CTL-9
901-9531-12,-12SF	SMA Angle Plug	Double Braid 316	.475(12.1)	.235(6.0)	.090(2.3)	.151(3.8)	227-1221-37 Cavity B	—
901-9881-RFX	SMA Angle Plug	174, 179, 187, 188, 316	.472(12.0)	.216(5.5)	.102(2.6)	.128(3.3)	227-1221-03 Cavity A	CTL-9
901-10014	SMA Angle Plug	LMR 240	.615(15.6)	.215(5.5)	.075(1.9)	.255(6.5)	227-1221-59 Cavity A	CTL-1

Assembly

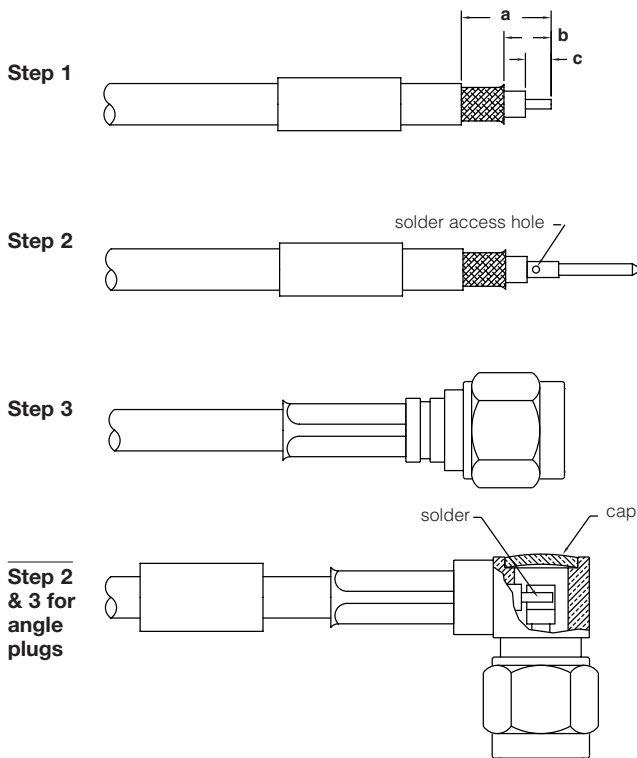

Step 1

Step 2

Step 3

Step 2 & 3 for angle plugs

**Step 1** Slide outer ferrule onto cable as shown. Strip cable jacket, braid and dielectric to dimensions shown in table. All cuts should be sharp and square. Do not nick braid, dielectric or center conductor when cutting.

**Step 2** Flare end of cable braid slightly as shown to facilitate insertion onto inner ferrule. Do not comb out braid. Solder center contact to cable (SN60-40 rosin core solder recommended.) Note: Center conductor should be visible through soft solder access hole in contact, prior to soldering.

**Step 3** Install body onto cable so that female portion slides under braid and insulator butts flush against cable dielectric. Slide outer ferrule over braid and up against body. Make sure no slack exists in braid. Crimp over ferrule with tool specified in table, keeping cable dielectric bottomed against insulator.

**Step 2 & 3** Angle Plugs: Place cable dielectric into body and press ferrule against body as shown. Crimp with die set shown in table above. Solder cable center conductor into contact as shown. Insert cap and solder as shown or dimple and lightly punch center of cap for retention in body, for brass versions. Place heat shrink tubing over crimp ferrule, against body, and apply heat.

### CRIMP-CRIMP TYPES FOR FLEXIBLE CABLE

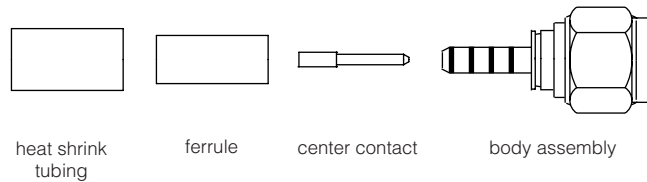

Amphenol Number	Connector Type	Cable RG-/U	Stripping Dimensions, inches (mm)			Contact Data Positioner for Tool 227-1454	Outer Ferrule Data			CTL Series Tool
			a	b	c		Positioner for M22520/1-01	Hex Cav. for Outer ferrule	Die Set for Tool 227-944	
901-101-15*	SMA Plug	142B, 400	.531(13.5)	.250(3.2)	.141(3.6)	—	/1-15	.213(5.4)	227-1221-11 Cav. A	CTL-1
901-9511-1SFC	SMA Plug	55, 58, 141, 142, 223, 400	.300(7.6)	—	.090(2.3)	227-1451-1	—	.213(5.4)	227-1221-11 Cav. A	CTL-1
901-9511-3*	SMA Plug	174, 179B,	.470(11.9)	.170(4.3)	.120(3.0)	227-1451-1	—	.128(3.3)	227-1221-03	CTL-139
901-9511-3SF*	SMA Plug	187A, 316	.470(11.9)	.170(4.3)	.120(3.0)	227-1451-1	—	.128(3.3)	227-1221-03	CTL-139
901-9511-3SFC	SMA Plug	174, 179, 187, 188, 316	.470(11.9)	.170(4.3)	.120(3.0)	227-1451-1	—	.128(3.3)	227-1221-03	CTL-139
901-9511-12SF*	SMA Plug	DbL. Br. 316	.470(11.9)	.170(4.3)	.120(3.0)	227-1451-1	—	.151(3.8)	227-1221-37 Cav. B	CTL-139
901-9511-12SFC	SMA Plug	DbL. Br. 316	.470(11.9)	.170(4.3)	.120(3.0)	227-1451-1	—	.151(3.8)	227-1221-37 Cav. B	CTL-139

#### Step 1

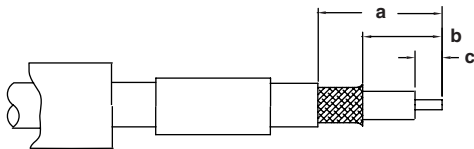

**Step 1** Slide heat shrink tubing and outer ferrule onto cable. Strip cable jacket, braid and dielectric to dimensions shown in table above. All cuts are to be sharp and square. Do not nick braid, dielectric or center conductor when cutting. Flare end of cable braid slightly as shown to facilitate insertion of inner ferrule. Do not comb out braid.

#### Step 2

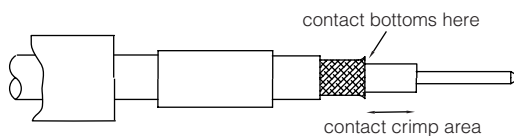

**Step 2 For crimp contact type only:**  
Crimp center contact to cable conductor using 8-indent Tool and Positioner shown in Table above. Note: Contact must bottom against cable dielectric.  
**\*For solder type connectors:**  
Solder contact to center conductor.

#### Step 3

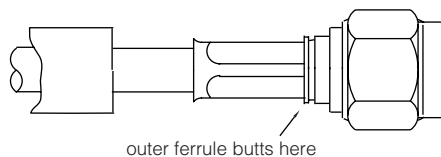

**Step 3** Install inner ferrule of body assembly over cable dielectric and under braid. Place outer ferrule against body and crimp with tool 227-944 (M22520/5-01) and die set shown in table above. Place heat shrink tubing over crimp ferrule, against body, and apply heat.

### BRAID CRIMP-SOLDER CENTER CONTACT TYPES FOR FLEXIBLE CABLE

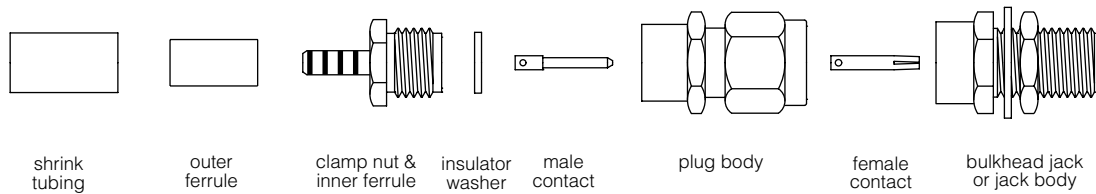

Amphenol Number	Connector Type	Cable RG-/U	Strip Dimensions, inches (mm)			Hex Cavity for Outer Ferrule	Die Set for Tool 227-944
			a	b	c		
901-9601-1SF	SMA Plug	55,58,141,142,223,400	.620(15.7)	.350(8.9)	.120(3.0)	.213(5.4)	227-1221-11 Cavity A
901-9601-3	SMA Plug	174,179,187,188,316	.620(15.7)	.350(8.9)	.120(3.0)	.128(3.3)	227-1221-03 Cavity A
901-9601-3SF	SMA Plug	174,179,187,188,316	.620(15.7)	.350(8.9)	.120(3.0)	.128(3.3)	227-1221-03 Cavity A
901-9602-1, -1SF	SMA Jack	55,58,141,142,223,400	.610(15.5)	.340(8.6)	.110(2.8)	.213(5.4)	227-1221-11 Cavity A
901-9602-3, -3SF	SMA Jack	174,179,187,188,316	.610(15.5)	.340(8.6)	.110(2.8)	.128(3.3)	227-1221-03 Cavity A
901-9602-12SF	SMA Jack	Double Braid 316	.610(15.5)	.340(8.6)	.110(2.8)	.128(3.3)	227-1221-03 Cavity A
901-9610-1SF	SMA Bulkhead Jack	55,58,141,142,223,400	.610(15.5)	.340(8.6)	.110(2.8)	.213(5.4)	227-1221-11 Cavity A
901-9610-3, -3SF	SMA Bulkhead Jack	174,179,187,188,316	.610(15.5)	.340(8.6)	.110(2.8)	.128(3.3)	227-1221-03 Cavity A
901-9610-12SF	SMA Bulkhead Jack	Double Braid 316	.610(15.5)	.340(8.6)	.110(2.8)	.151(3.8)	227-1221-37 Cavity B
901-10015	SMA Bulkhead Jack	LMR 240	4.93(12.5)	—	.043(2.4)	.255(6.5)	227-1221-59 Cavity A

#### Step 1

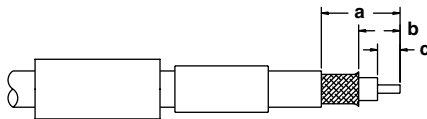

**Step 1** Slide heat shrink tubing and outer ferrule onto cable. Strip cable jacket, braid and dielectric to dimensions shown in table above. All cuts are to be sharp and square. Do not nick braid, dielectric or center conductor when cutting. Tin center conductor. Avoid excessive heat to prevent swelling of cable dielectric. Flare end of cable braid slightly as shown to facilitate insertion of inner ferrule. Do not comb out braid.

#### Step 2

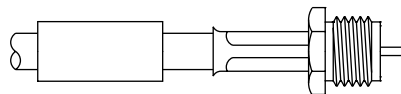

**Step 2** Slide clamp nut over inner ferrule, and slide inner ferrule under braid until cable dielectric is flush with front of inner ferrule. Slide outer ferrule in place and crimp with die set shown in table above.

#### Step 3

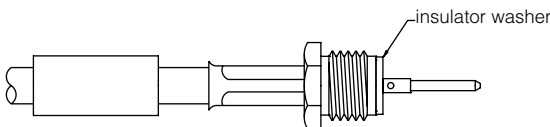

**Step 3** Place insulator washer on cable center conductor and bottom against inner ferrule body as shown. Contact must butt firmly against insulator washer while soldering.

#### Step 4

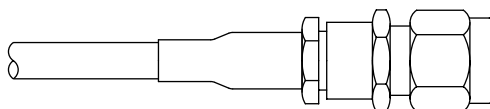

**Step 4** Screw ferrule-contact assembly into body and tighten to 20-25 lbf.-in. torque. Slide heat shrink tubing over ferrule, up against clamp nut and shrink by applying heat.

## BRAID CRIMP-SOLDER CENTER CONTACT TYPES FOR RG-174 & RG-179 CABLE GROUPS

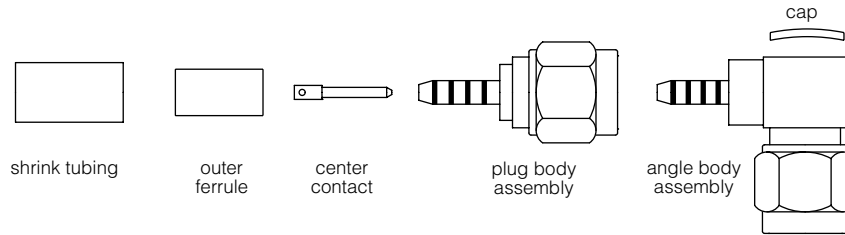

Amphenol Number	Connector Type	Cable RG-/U	Stripping Dimensions, inches (mm)			Hex Cavity for Outer Ferrule	Die Set for Tool 227-944	CTL Series Tool
			a	b	c			
901-9531-3, -3SF	SMA Angle Plug	174, 179, 187, 188, 316	.475(12.1)	.235(6.0)	.090(2.3)	.128(3.3)	227-1221-03 Cavity A	CTL-9
901-9872	SMA Angle Plug	174, 179, 187, 188, 316	.472(12.0)	.216(5.5)	.102(2.6)	.128(3.3)	227-1221-03 Cavity A	CTL-9
901-9877	SMA Plug	174, 179, 187, 188, 316	.421(10.7)	.165(4.2)	.098(2.5)	.128(3.3)	227-1221-03 Cavity A	CTL-9
901-9916	SMA Plug	174, 179, 187, 188, 316	.421(10.7)	.165(4.2)	.098(2.5)	.128(3.3)	227-1221-03 Cavity A	CTL-9
901-9531-12, -12SF	SMA Angle Plug	Double Braid 316	.475(12.1)	.235(6.0)	.090(2.3)	.151(3.8)	227-1221-37 Cavity B	—
901-9881	SMA Angle Plug	174, 179, 187, 188, 316	.472(12.0)	.216(5.5)	.102(2.6)	.128(3.3)	227-1221-03 Cavity A	CTL-9

### Step 1

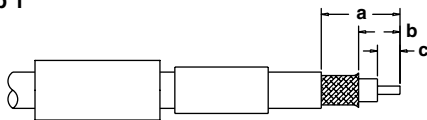

**Step 1** Slide heat shrink tubing and outer ferrule onto cable. Strip cable jacket, braid and dielectric to dimensions shown in table above. All cuts are to be sharp and square. Do not nick braid, dielectric or center conductor when cutting. Tin center conductor. Avoid excessive heat to prevent swelling of cable dielectric. Flare end of cable braid slightly as shown to facilitate insertion of inner ferrule. Do not comb out braid.

### Step 2

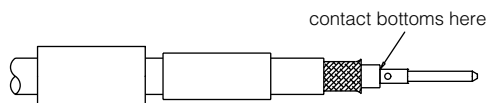

**Step 2** Solder center contact to cable center conductor as shown. Remove excess solder. **Note:** Contact must bottom against cable dielectric. (For angle plugs skip to Step 3B below.)

### Step 3

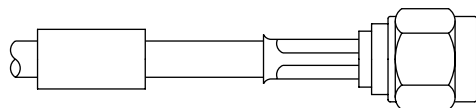

**Step 3** Install coupling nut and body assembly as shown. Place ferrule against body and crimp with die set shown in table above. Place heat shrink tubing over crimp ferrule, against body, and apply heat.

### Step 3B for angle plugs

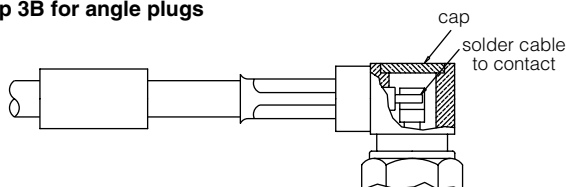

**Step 3B** For angle plugs: Place cable dielectric into body and press ferrule against body as shown. Crimp with die set shown in table above. Solder cable center conductor into contact as shown. Insert cap and solder as shown or dimple and lightly punch center of cap for retention in body, for brass versions. Place heat shrink tubing over crimp ferrule, against body, and apply heat.

## BRAID CRIMP-SOLDER CENTER CONTACT TYPES FOR FLEXIBLE CABLE

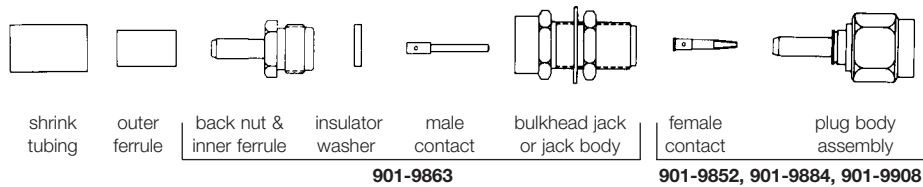

Amphenol Number	Connector Type	Cable RG-/U	Strip Dimensions, inches (mm)			Hex Cavity for Outer Ferrule	Die Set for Tool 227-944
			a	b	c		
901-9884	Plug	55, 142, 223, 400	.480 (12.2)	.250 (6.4)	.140 (3.6)	.213 (5.4)	227-1221-11 Cavity A
901-9852	Plug	174,179,187,188,316	.500 (12.7)	.260 (6.6)	.150 (3.8)	.128 (3.3)	227-1221-3 Cavity A
901-9863	Bulkhead Jack	174,179,187,188,316	.610 (15.5)	.340 (8.6)	.110 (2.8)	.128 (3.3)	227-1221-3 Cavity A
901-9908	Angle Plug	223	.475 (12.1)	.235 (6.0)	.120 (3.0)	.213 (5.4)	227-1221-11 Cavity A
901-9990	Bulkhead Jack	178, 196	.255 (6.5)	.105 (2.67)	.075 (1.8)	.105 (2.67)	227-1221-03 Cavity B

### Step 1

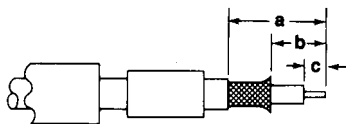

### Step 1

Slide heat shrink tubing and outer ferrule onto cable. Strip cable jacket, braid and dielectric to dimensions shown in table above. All cuts are to be sharp and square. Do not nick braid, dielectric or center conductor when cutting. Tin center conductor. Avoid excessive heat to prevent swelling of cable dielectric. Flare end of cable braid slightly as shown to facilitate insertion of inner ferrule. Do not comb out braid.

### For 901-9863 RP-Bulkhead Jack

#### Step 2

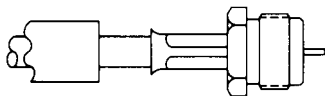

### Step 2

Slide clamp nut over inner ferrule, and slide inner ferrule under braid until cable dielectric is flush with front of inner ferrule. Slide outer ferrule in place and crimp with die set shown in table above.

#### Step 3

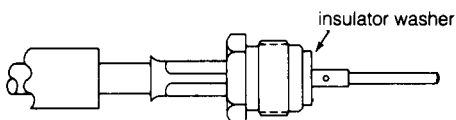

### Step 3

Place insulator washer on cable center conductor and bottom against inner ferrule body as shown. Contact must butt firmly against insulator washer while soldering.

#### Step 4

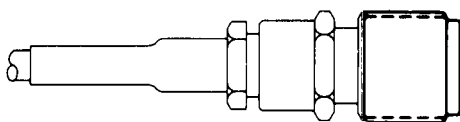

### Step 4

Screw ferrule-contact assembly into body and tighten to 20-25 lbf.-in. torque. Slide heat shrink tubing over ferrule, up against clamp nut and shrink by applying heat.

### For 901-9884, 901-9852, 901-9908 RP Plugs

#### Step 2

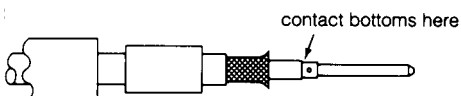

### Step 2

Solder center contact to cable center conductor as shown. Remove excess solder. Note: Contact must bottom against cable dielectric.

#### Step 3

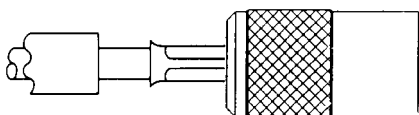

### Step 3

Install coupling nut and body assembly as shown. Place ferrule against body and crimp with die set shown in table above. Place heat shrink tubing over crimp ferrule, against body, and apply heat.



## SOLDER TYPES FOR .141" SEMI-RIGID CABLE

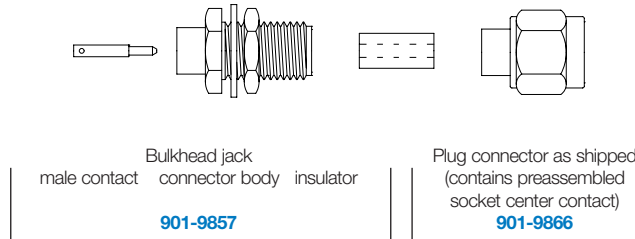

**Step 1**

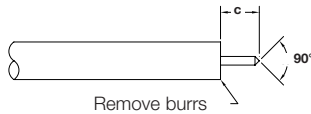

**Step 1**

Clean cable end for .625"(16mm) min. length. Trim cable jacket and dielectric to  $c = .090(2.3)$  for 901-9866 or  $c = .125(3.2)$  for 901-9857. Do not nick center conductor. Remove burrs from cable jacket and center conductor. For 901-9866, file blunt end of center conductor to a 90° cone.

**Step 2  
for 901-9866 RP-Plug  
RP-Plug**

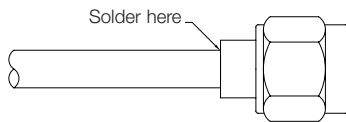

**Step 2**

For 901-9866 assemble cable into connector body. Make sure center conductor is straight. Use care in pushing center conductor into spring contact. Make sure jacket bottoms in connector. Maintain end pressure while soldering. Avoid excessive heat which may distort dielectric.

**Step 2  
for 901-9857  
RP-Bu**

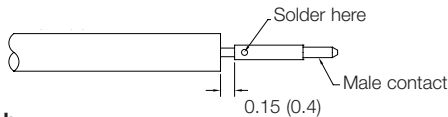

**Step 2**

For 901-9857 solder contact to center conductor. Use .015"(.4mm) shim to accurately maintain space between jacket, dielectric and contact. Remove all excess solder.

**Step 3a, b**

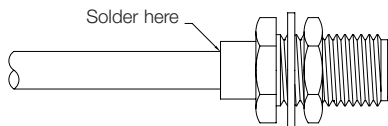

**Step 3a**

Assemble cable and contact into connector body. Cable jacket and dielectric to be flush with shoulder of body as shown. Solder cable to connector body. Avoid excessive heat which may distort dielectric.

**Step 3b**

Press fit insulator into connector body. Bottom insulator in connector body as shown.

## CRIMP TYPE PLUGS & BULKHEAD JACKS

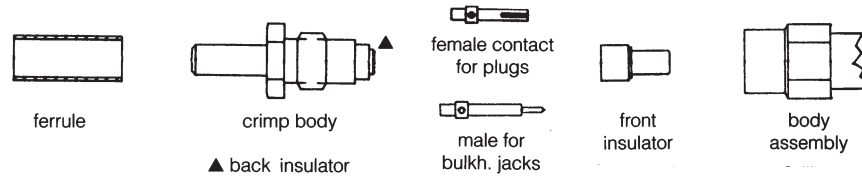

Amphenol Number	Connector Type	Cable RG-/U	Hex Cavity for Outer Ferrule	Die Set for Tool Handle 227-944	Stripping Dimensions, Inches (MM)		
					a	b	c
<a href="#">903-108J-71S</a>	75Ω SMB Bulkhead Jack	179	.128(3.3)	227-1221-03 Cav. A	.673(17.1)	.433(11.0)	.093(2.4)
<a href="#">903-152P-71S</a>	75Ω SMB Plug	180, 195	.178(4.5)	227-1221-09 Cav. A	.673(17.1)	.433(11.0)	.093(2.4)
<a href="#">903-285P-51S</a>	50Ω SMB Plug	174, 179, 187, 188, 316	.128(3.3)	227-1221-03 Cav. A	.642(16.3)	.402(10.2)	.080(2.0)
<a href="#">903-287P-51S</a>	50Ω SMB Plug	178, 196	.105(2.7)	227-1221-03 Cav. B	.642(16.3)	.402(10.2)	.080(2.0)
<a href="#">903-370P-51S</a>	50Ω SMB Plug	174, 179, 187, 188, 316	.128(3.3)	227-1221-03 Cav. A	.642(16.3)	.402(10.2)	.080(2.0)
<a href="#">903-371P-51S</a>	50Ω SMB Plug	178, 196	.105(2.7)	227-1221-03 Cav. B	.642(16.3)	.402(10.2)	.080(2.0)
<a href="#">903-401P-51S</a>	50Ω SMB Plug	Dbl. Shield 316	.151(3.8)	227-1221-37 Cav. B	.642(16.3)	.402(10.2)	.080(2.0)
<a href="#">903-502P-71S</a>	75Ω SMB Plug	174, 179, 187, 188, 316	.128(3.3)	227-1221-03 Cav. A	.460(11.7)	.210(5.3)	.110(2.5)
<a href="#">903-505J-51S</a>	50Ω SMB Jack	174, 188, 316	.128(3.3)	227-1221-03 Cav. A	.405(10.3)	.180(4.6)	.093(2.4)
<a href="#">903-505J-51S1</a>	50Ω SMB Jack	Dbl. Shield 316	.128(3.3)	227-1221-03 Cav. A	.405(10.3)	.180(4.6)	.093(2.4)
<a href="#">903-284P-52S</a>	50Ω SMC Plug	174, 188, 316	.128(3.3)	227-1221-03 Cav. A	.642(16.3)	.402(10.2)	.080(2.0)
<a href="#">903-284P-52S1</a>	50Ω SMC Plug	RD-316	.128(3.3)	227-1221-03 Cav. A	.642(16.3)	.402(10.2)	.080(2.0)

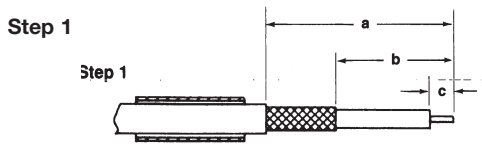

**Step 1** Slide ferrule over cable. Trim cable to dimensions shown in table above. Tin center conductor.

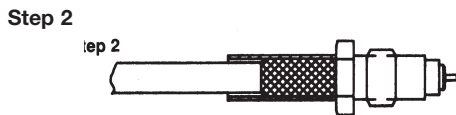

**Step 2** Insert cable into back end of crimp body assembly as shown. Dielectric will bottom in back insulator. Slide ferrule over braid and crimp using hex die shown in table above.

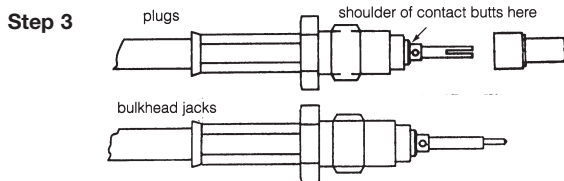

**Step 3** Assemble contact over center conductor so that shoulder of contact butts against back insulator. Heat contact to solder. For SMB plugs: After soldering contact, assemble front insulator over contact.

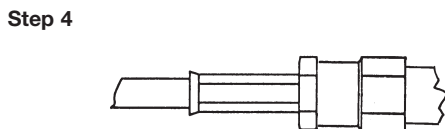

**Step 4** Insert assembly into body assembly and tighten to a torque of 90 to 100 ozf-in.

## CRIMP TYPE ANGLE PLUGS & ANGLE BULKHEAD JACKS

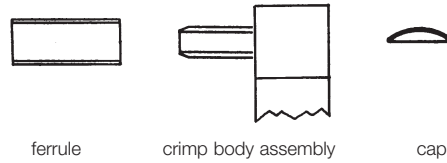

Amphenol Number	Connector Type	Cable RG-/U	Hex Cavity for Outer Ferrule	Die Set for Tool Handle 227-944	Stripping Dimensions, Inches (mm)		
					a	b	c
903-517P-71A	75Ω SMC Angle Plug	Belden 735A	.178(4.5)	227-1221-09 Cav. A	.440(11.2)	.180(4.57)	.090(2.28)
903-289P-51A	50Ω SMB Angle Plug	174, 179, 187, 188, 316	.128(3.3)	227-1221-03 Cav. A	.390(9.9)	.150(3.8)	.050(1.3)
903-289P-51A2	50Ω SMB Angle Plug	174, 179, 187, 188, 316	.128(3.3)	227-1221-03 Cav. A	.390(9.9)	.150(3.8)	.050(1.3)
903-291P-51A	50Ω SMB Angle Plug	178, 196	.105(2.7)	227-1221-03 Cav. B	.390(9.9)	.150(3.8)	.050(1.3)
903-291P-51A1	50Ω SMB Angle Plug	178, 196	.105(2.7)	227-1221-03 Cav. B	.390(9.9)	.150(3.8)	.050(1.3)
903-367P-51A	50Ω SMB Angle Plug	174, 179, 187, 188, 316	.128(3.3)	227-1221-03 Cav. A	.390(9.9)	.150(3.8)	.050(1.3)
903-367P-51A1	50Ω SMB Angle Plug	174, 179, 187, 188, 316	.128(3.3)	227-1221-03 Cav. A	.390(9.9)	.150(3.8)	.050(1.3)
903-367P-51A2	50Ω SMB Angle Plug	174, 179, 187, 188, 316	.128(3.3)	227-1221-03 Cav. A	.390(9.9)	.150(3.8)	.050(1.3)
903-368P-51A	50Ω SMB Angle Plug	178, 196	.105(2.7)	227-1221-03 Cav. B	.390(9.9)	.150(3.8)	.050(1.3)
903-368P-51A1	50Ω SMB Angle Plug	178, 196	.105(2.7)	227-1221-03 Cav. B	.390(9.9)	.150(3.8)	.050(1.3)
903-369P-51A	50Ω SMB Angle Plug	Dbl. Braid RG-316	.151(3.8)	227-1221-37 Cav. B	.390(9.9)	.150(3.8)	.050(1.3)
903-369P-51A2	50Ω SMB Angle Plug	Dbl. Braid RG-316	.151(3.8)	227-1221-37 Cav. B	.390(9.9)	.150(3.8)	.050(1.3)
903-422J-51A	50Ω SMB Ang.BlkH Jack	174, 179, 187, 188, 316	.128(3.3)	227-1221-03 Cav. A	.390(9.9)	.150(3.8)	.050(1.3)
903-429P-51A	50Ω SMB Low Prof. Angl Plg	174, 179, 187, 188, 316	.128(3.3)	227-1221-03 Cav. A	.400(10.2)	.200(5.1)	.050(1.3)
903-495P-71A	75Ω SMB Angle Plug	Belden 9248	.324(8.2)	227-1221-32 Cav. A	.500(12.7)	.250(6.4)	.250(6.4)
903-535P-71A	75Ω SMB Angle Plug	179	.178(4.5)	227-1221-09 Cav. A	.440(11.2)	.180(4.57)	.090(2.28)
903-288P-52A	75Ω SMB Angle Plug	174, 188, 316	.128(3.3)	227-1221-03 Cav. A	.390(9.9)	.150(3.2)	.050(1.3)
903-362P-52A1	75Ω SMB Angle Plug	RD-316	.151(3.8)	227-1221-37 Cav. B	.390(9.9)	.150(3.2)	.050(1.3)

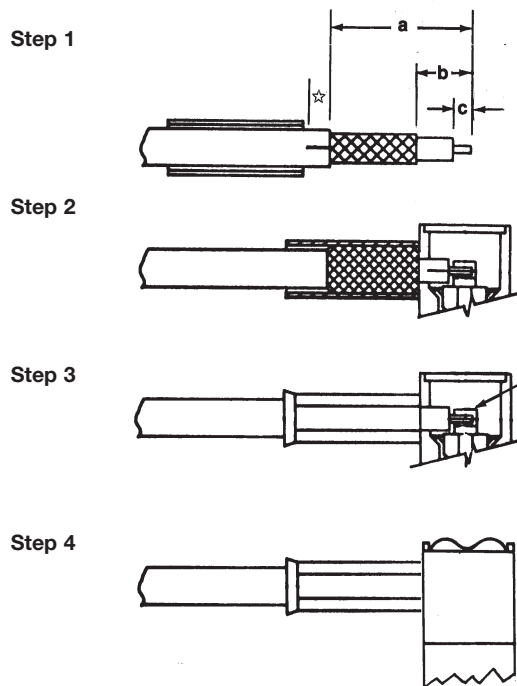

**Step 1** Slide ferrule over cable. Trim cable to dimensions shown in table above. Tin center conductor.  
 ☆ for P/N 903-429P-51A only, make 2 slits in jacket .062"(1.6mm) long, 180° apart.

**Step 2** Insert cable into back end of crimp body assembly as shown. Center conductor will enter slot in contact. Slide ferrule over braid and crimp using hex die shown in table above.

**Step 3** Solder center conductor into contact.

**Step 4** Insert cap into body and dimple or lightly punch center of cap for retention in body.

## CRIMP TYPE PLUGS

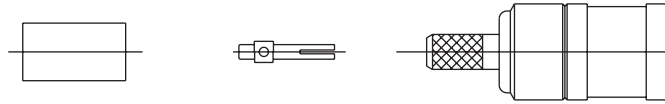

Amphenol Number	Connector Type	Cable RG-/U	Hex Cavity for Outer Ferrule	Die Set for Tool Handle 227-944	Stripping Dimensions, Inches (MM)		
					a	b	c
903-508P-51S	50Ω SMB Plug	174, 188, 316	.128 (3.3)	227-1221-03 Cav. A	.390 (9.9)	.185 (6.7)	.079 (2.0)
903-509P-51S	50Ω SMB Plug	178, 196	.105 (2.7)	227-1221-03 Cav. B	.390 (9.9)	.185 (6.7)	.079 (2.0)
903-516P-71S	75Ω SMB Plug	Belden 735A	.178 (4.5)	227-1221-09 Cav. A	.480 (12.2)	.190 (4.83)	.110 (2.79)
903-536P-71S	75Ω SMB Plug	179	.128 (3.3)	227-1221-03 Cav. A	.480 (12.2)	.190 (4.83)	.110 (2.79)
903-577P-51S1	50Ω SMB Plug	174, 188, 316	.128 (3.3)	227-1221-03 Cav. A	.450(11.4)	.190 (4.83)	.110 (2.79)
903-577P-51S	50Ω SMB Plug	174, 188, 316	.128 (3.3)	227-1221-03 Cav. A	.450(11.4)	.190 (4.83)	.110 (2.79)
903-578P-51S1	50Ω SMB Plug	178, 196	.105 (2.67)	227-1221-03 Cav. B	.450(11.4)	.190 (4.83)	.110 (2.79)
903-578P-51S	50Ω SMB Plug	178, 196	.105 (2.67)	227-1221-03 Cav. A	.450(11.4)	.190 (4.83)	.110 (2.79)
903-579P-51S1	50Ω SMB Plug	RD-316	.151 (3.84)	227-1221-37 Cav. B	.450(11.4)	.190 (4.83)	.110 (2.79)
903-579P-51S	50Ω SMB Plug	RD-316	.151 (3.84)	227-1221-37 Cav. B	.450(11.4)	.190 (4.83)	.110 (2.79)
903-574P-71S	75Ω SMB Plug	179	.128 (3.3)	227-1221-03 Cav. A	.625(15.8)	.365(9.3)	.100(2.5)
903-575P-71S	75Ω SMB Plug	RD-179	.151(3.84)	227-1221-37 Cav. B	.625(15.8)	.365(9.3)	.100(2.5)

**Step 1**

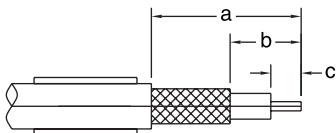

**Step 1** Slide ferrule over cable. Trim cable to dimensions shown in table above.

**Step 2**

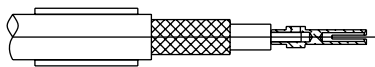

**Step 2** Tin center conductor  
Assemble contact over center conductor so that shoulder of contact butts against cable dielectric. Heat contact to solder.

**Step 3**

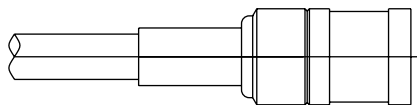

**Step 3** Insert cable and contact into back end of crimp body. Contact shoulder will bottom in insulator. Slide ferrule over braid and crimp using hex die shown in table above.

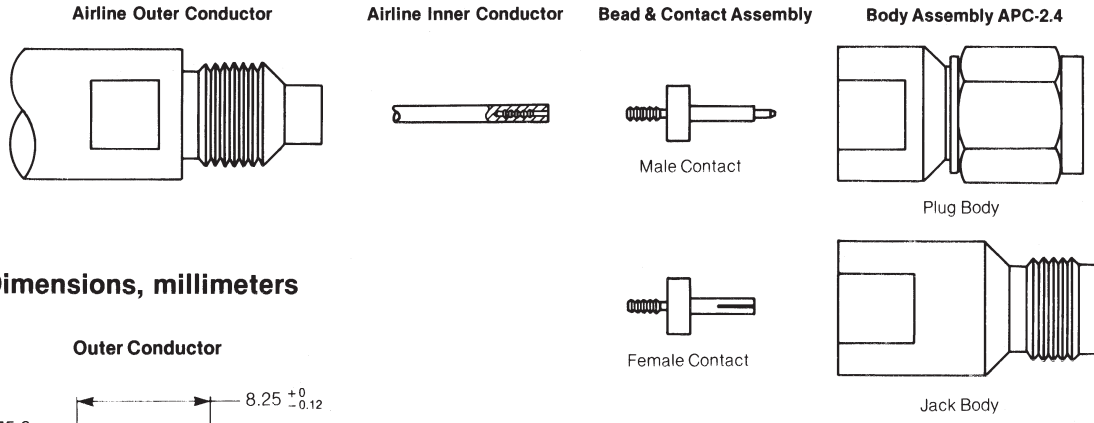

### Dimensions, millimeters

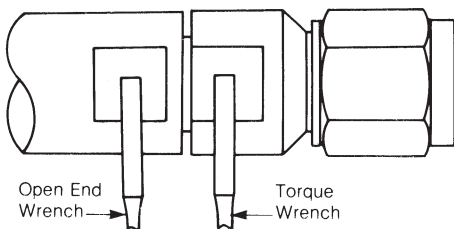
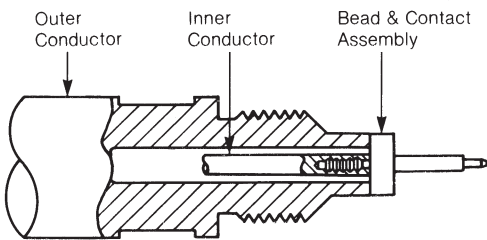
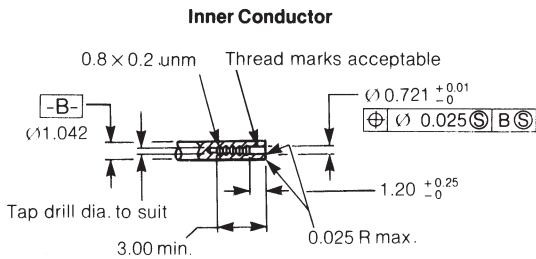
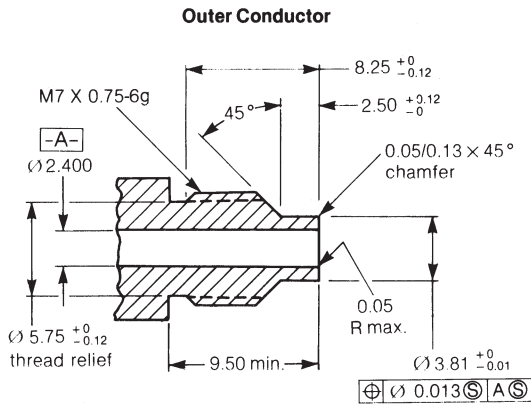

### Step 1

**AIRLINE PREPARATION.** Prepare outer and inner conductors to dimensions shown. Strict adherence to dimensional tolerances is required for precision performance.

### Step 2

**CONNECTOR ASSEMBLY.** Thread bead and contact assembly into airline inner conductor until finger tight and place into outer conductor as shown.

### Step 3

Carefully guide the body assembly over the bead and contact assembly and onto the airline outer conductor. Seat the airline outer conductor in the assembly. Thread the body assembly until it is finger tight.

Secure the assembly by wrench tightening the body assembly to the airline outer conductor with a torque of 2.03 inch to 2.49 N-m (18 to 22 inch pounds).

# Assembly Instructions - C66 APC 3.5 Airline

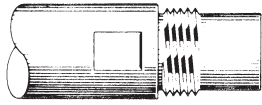

**OUTER CONDUCTOR**  
Factory prepared P/N 131-7502



**INNER CONDUCTOR**  
Factory prepared P/N 131-7501

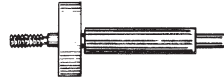

**BEAD & CONTACT ASSEMBLY**

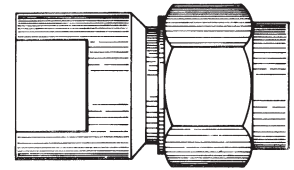

**BODY ASSEMBLY APC-3.5**

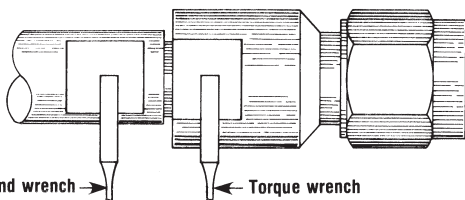
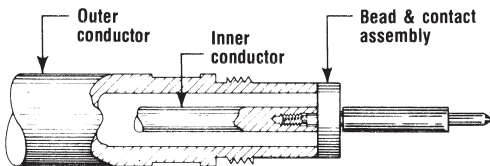
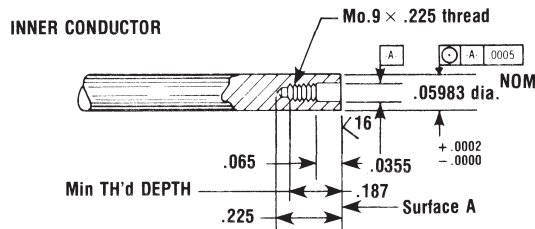
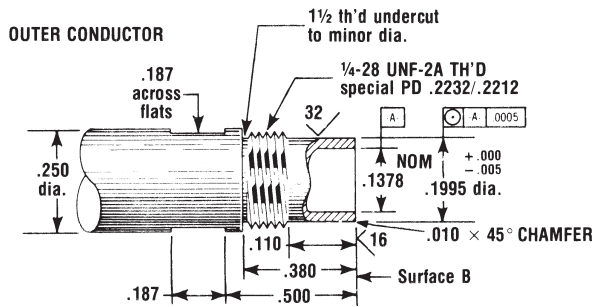

**Step 1**

**AIRLINE PREPARATION.** Prepare outer and inner conductors to dimensions shown. Strict adherence to dimensional tolerances is required for precision performance.

Surface A of inner conductor must be flush to .0005 below Surface B of outer conductor.

**Step 2**

**CONNECTOR ASSEMBLY.** Thread bead and contact assembly into airline inner conductor until finger tight and place into outer conductor as shown.

**Step 3**

Carefully guide the body assembly over the bead and contact assembly and onto the airline outer conductor. Seat the airline outer conductor in the assembly. Thread the body assembly until it is finger tight.

Secure the assembly by wrench tightening the body assembly to the airline outer conductor with a torque of 30 inch pounds.

# Assembly Instructions - C67 APC-7, APC-7S, APC-N Airline

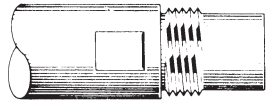

**OUTER CONDUCTOR**  
Factory prepared P/N 131-2094-4  
or precision tubing P/N 131-2027

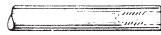

**INNER CONDUCTOR**  
Factory prepared P/N 131-2028-4  
or precision rod P/N 131-2026

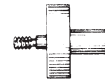

**BEAD & CONTACT  
ASSEMBLY**

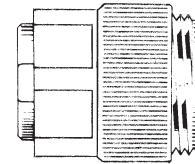

**BODY ASSEMBLY APC-7 ILLUSTRATED**

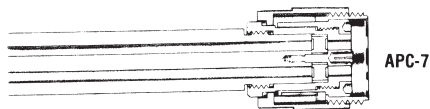
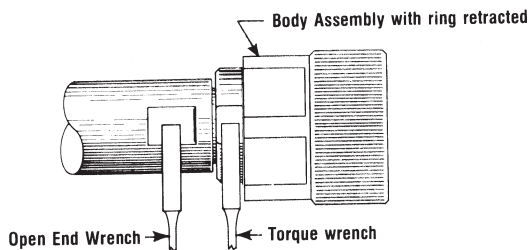
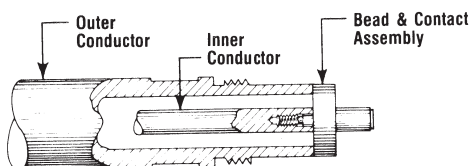
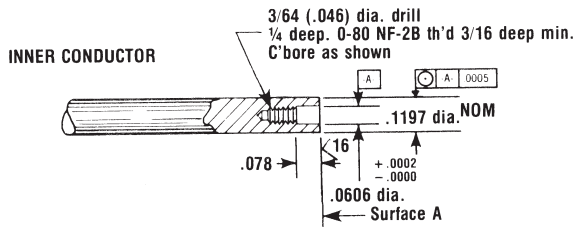
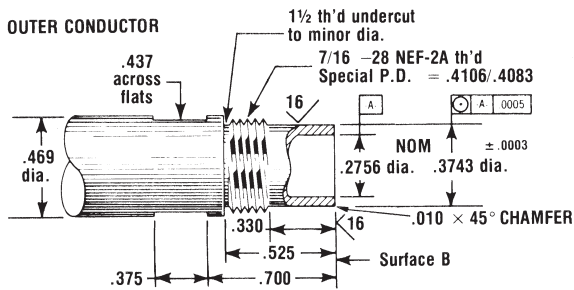

NOTE: The APC-7 is used here for illustration only. These instructions also apply to APC-N to APC-7S plug and jack designs for 7mm air line.

**Step 1**  
AIRLINE PREPARATION. Prepare outer and inner conductors to dimensions shown. Strict adherence to dimensional tolerances is required for precision performance.

Surface A of inner conductor must be flush to .0005 below Surface B of outer conductor.

**Step 2**  
CONNECTOR ASSEMBLY. Thread bead and contact assembly into airline inner conductor until finger tight and place into outer conductor as shown.

**Step 3**  
(APC-7 connector only — Retract the threaded retainer ring by threading it back into the coupling nut. The coupling nut should now float freely on the body assembly making the wrench flats accessible.)

Carefully guide the body assembly over the bead and contact assembly and onto the airline outer conductor. Seat the airline outer conductor in the assembly. Thread the body assembly until it is finger tight.

Secure the assembly by wrench tightening the body assembly to the airline outer conductor with a torque of 30 inch pounds.

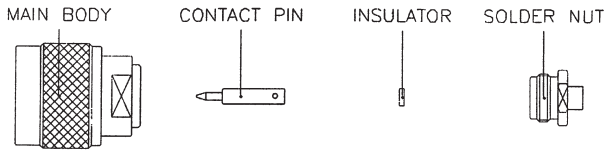

**Step 1** All parts of the connector are shown.

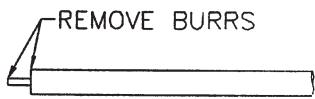

**Step 2** Strip the inner conductor, dielectric, and jacket as per "RECOMMENDED CABLE STRIPPING DIM'S" in catalog.

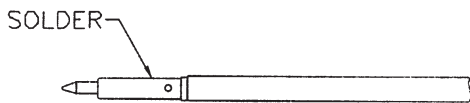

**Step 3** Slide the INSULATOR onto inner conductor against the jacket. Then insert conductor into the CONTACT PIN and solder it as shown.

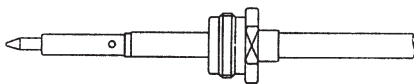

**Step 4** Slide the SOLDER NUT onto cable.

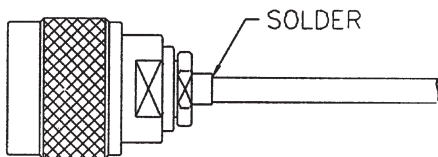

**Step 5** Insert cable and parts into the MAIN BODY, then screw the SOLDER NUT until it is tight and solder it as shown.



### STRAIGHT CONNECTORS FOR FLEXIBLE CABLE

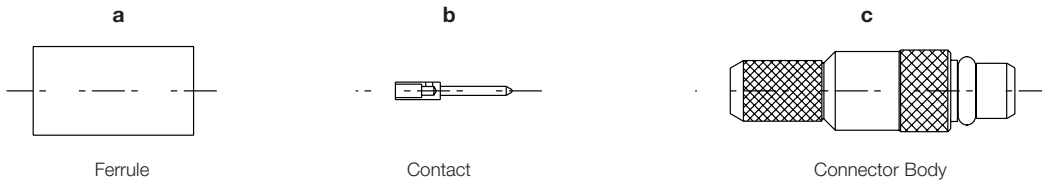

Amphenol Number	Connector Type	Cable RG-/U	Hex Crimp Data		Stripping Dimensions, inches (mm)		
			Cavity for Outer Ferrule	CTL Series Tool No.	d	e	f
908-41200	Straight Plug	RG-178, 196	.105 (2.67)	CTL-13	.170 (4.32)	.300 (7.62)	.360 (9.14)
908-41300	Straight Plug	RG-174, 188, 316	.128 (3.25)	CTL-13	.170 (4.32)	.300 (7.62)	.340 (8.64)
908-41500	Straight Plug	RD-316	.151 (3.84)	CTL-13	.170 (4.32)	.300 (7.62)	.340 (8.64)
908-42300	Straight Jack	RG-174, 188, 316	.128 (3.25)	CTL-13	.170 (4.32)	.300 (7.62)	.340 (8.64)
908-42500	Straight Jack	RD-316	.151 (3.84)	CTL-13	.170 (4.32)	.300 (7.62)	.340 (8.64)

**Step 1** Prepare cable according to diagram. Do not damage braid and inner conductor of cable. Slide crimp ferrule "a" over the braid.

**Step 2** Solder contact "b" to the center conductor of the cable. Contact must butt on the dielectric of the cable as shown.

**Step 3** Flare braid and insert contact into body assembly "c". Contact must bottom in insulator resulting in a dimension of .006 ±.007 from the tip of the contact to the end of the body. Crimp ferrule using the appropriate hex dies.

Assembly

## STRAIGHT CONNECTORS FOR SEMI-RIGID CABLE

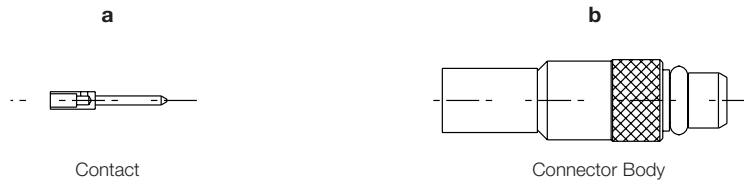

Amphenol Number	Connector Type	Cable RG-/U	Stripping Dimensions, inches (mm)	
			c	d
908-41400	Straight Plug	.086 Semi-Rigid	.180 (4.57)	.140 (3.56)
908-41600	Straight Plug	.047 Semi-Rigid	.200 (5.08)	.140 (3.56)

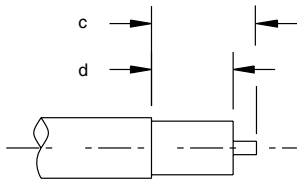

**Step 1** Prepare cable according to diagram. Remove burrs from outer/inner conductors of cable.

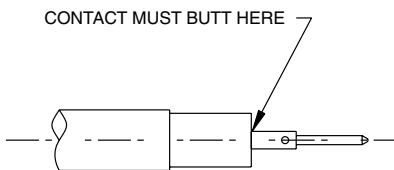

**Step 2** Solder center contact "a" to inner conductor of cable using Sn60 solder. Contact must butt on dielectric of cable as shown.

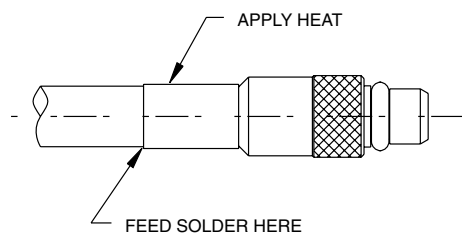

**Step 3** Insert contact into body assembly "b" as shown. Holding body and cable firmly, apply heat as shown and feed solder (Sn-60) as indicated. Allow to cool. The dimension from the contact tip to the end of the body should be  $.006 \pm .007$ .

## RIGHT ANGLE CONNECTORS FOR FLEXIBLE CABLE

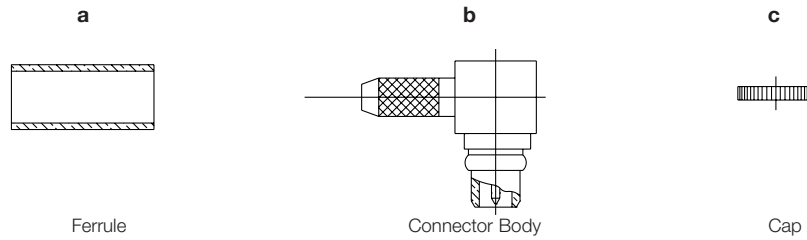

Amphenol Number	Connector Type	Cable RG-/U	Hex Crimp Data		Stripping Dimensions, inches (mm)		
			Cavity for Outer Ferrule	CTL Series Tool No.	d	e	f
908-43200	Right Angle Plug	RG-178, 196	.105 (2.67)	CTL-13	.170 (4.32)	.235 (5.97)	.285 (7.24)
908-43300	Right Angle Plug	RG-174, 188, 316	.128 (3.25)	CTL-13	.170 (4.32)	.235 (5.97)	.285 (7.24)
908-43500	Right Angle Plug	RD-316	.151 (3.84)	CTL-13	.170 (4.32)	.235 (5.97)	.285 (7.24)

**Step 1** Prepare cable according to diagram. Do not damage braid and inner conductor of cable. Slide crimp ferrule "a" over the braid.

BRAID AND DIELECTRIC

**Step 2** Flare braid and insert into body. Slide crimp ferrule over body and crimp the ferrule using appropriate crimp tool and die cavity.

CRIMP ZONE

**Step 3** Solder inner conductor to contact (Sn 60 recommended). Place cap "c" on rear opening of body "b". Press cap "c" into housing "b" with a flat punch or tool #908-50100.

SOLDER

Assembly

## RIGHT ANGLE CONNECTORS FOR SEMI-RIGID CABLE

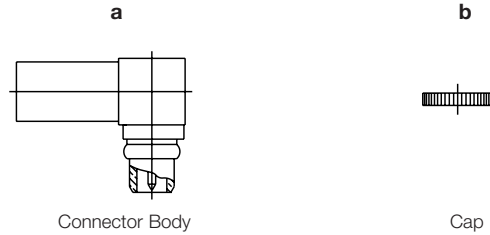

Amphenol Number	Connector Type	Cable RG-/U	Stripping Dimensions, inches (mm)	
			c	d
908-43400	Right Angle Plug	.086 Semi-Rigid	.090 (2.29)	.050 (1.27)
908-43600	Right Angle Plug	.047 Semi-Rigid	.090 (2.29)	.050 (1.27)

**Step 1** Prepare cable as shown. Remove burrs from outer/inner conductor of cable.

---

**Step 2** Insert cable into connector until it bottoms on shoulder of body. Solder outer conductor (Sn-60) recommended.

---

**Step 3** Solder inner conductor to contact (Sn-60 recommended). Place cover "b" on rear opening of body "A". Press cap "b" into housing "a" with a flat punch or tool #908-50100.

## STRAIGHT CONNECTORS FOR FLEXIBLE CABLE

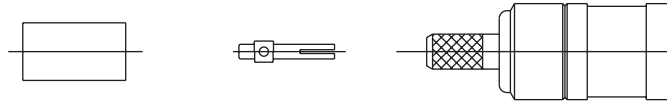

Amphenol Number	Connector Type	Cable RG-/U	Hex Cavity for Outer Ferrule	Die Set for Tool Handle 227-944	Stripping Dimensions, Inches (MM)		
					a	b	c
919-101P-51SX	50Ω MCX Plug	174, 188, 316	1.28 (3.25)	CTL-13	.385	.181	.098
919-101P-51S1X	50Ω MCX Plug	174, 188, 316	1.28 (3.25)	CTL-13	.385	.181	.098
919-107J-51SX	50Ω MCX Jack	174, 188, 316	1.28 (3.25)	CTL-13	.385	.181	.098
919-107J-51S1X	50Ω MCX Jack	174, 188, 316	1.28 (3.25)	CTL-13	.385	.181	.098
919-121P-51SX	50Ω MCX Plug	178, 196	1.05 (2.67)	CTL-13	.385	.181	.098
919-131J-51SX	50Ω MCX Jack	178, 196	1.05 (2.67)	CTL-13	.385	.181	.098
919-130P-51SX	50Ω MCX Plug	RD-316	.151 (3.84)	CTL-13	.385	.181	.098
919-128J-51SX	50Ω MCX Jack	174, 188, 316	.128 (3.25)	CTL-13	.385	.181	.098
919-129J-51SX	50Ω MCX Jack	RD-316	.151 (3.84)	CTL-13	.385	.181	.098
919-137P-51SX	50Ω MCX Plug	179	.128 (3.25)	CTL-13	.385	.181	.098
919-137P-51S2X	50Ω MCX Plug	RD-179	.151 (3.84)	CTL-13	.385	.181	.098

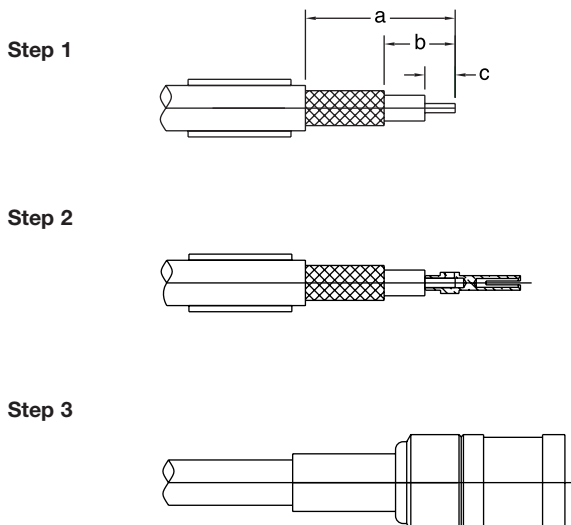

**Step 1** Slide ferrule over cable. Trim cable to dimensions shown in table above.

**Step 2** Tin center conductor  
Assemble contact over center conductor so that shoulder of contact butts against cable dielectric. Heat contact to solder.

**Step 3** Insert cable and contact into back end of crimp body. Contact shoulder will bottom in insulator. Slide ferrule over braid and crimp using hex die shown in table above.

## STRAIGHT CONNECTORS FOR SEMI-RIGID CABLE



Amphenol Number	Connector Type	Cable RG-/U	Stripping Dimensions, inches (mm)	
			c	d
919-114J-51SX	Straight Jack	.086 Semi-Rigid	.118	.039
919-120P-51SX	Straight Plug	.086 Semi-Rigid	.100	-

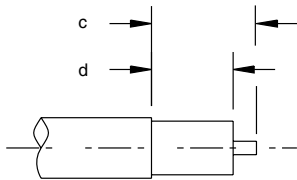

**Step 1** Prepare cable according to diagram. Remove burrs from outer/inner conductors of cable.

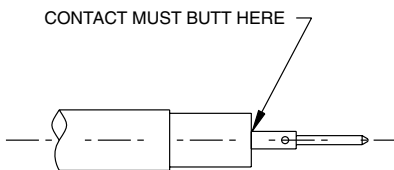

**Step 2** Solder center contact "a" to inner conductor of cable using Sn60 solder. Contact must butt on dielectric of cable as shown.

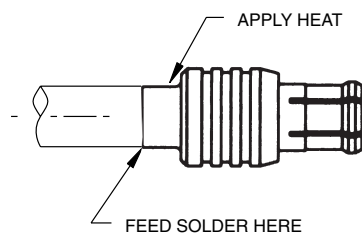

**Step 3** Insert contact into body assembly "b" as shown. Holding body and cable firmly, apply heat as shown and feed solder (Sn-60) as indicated. Allow to cool. The dimension from the contact tip to the end of the body should be  $.006 \pm .007$ .

## RIGHT ANGLE PLUGS FOR SEMI-RIGID CABLE

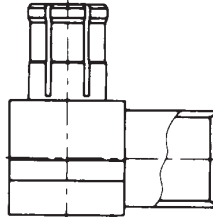

Amphenol Number	Connector Type	Cable RG/U	Dim c	Dim d
<a href="#">919-102P-51AX</a>	MCX Angle Plug	.086 Semi Rigid	.157	.051
<a href="#">919-103P-51AX</a>	MCX Angle Plug	.141 Semi Rigid	.157	.051

### Step 1

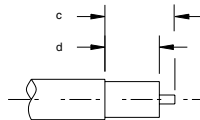

**Step 1** Clean cable end for .625"(16mm) min. length. Trim cable jacket and dielectric to dimension shown. Do not nick center conductor. Remove burrs from cable jacket and center conductor.

### Step 2

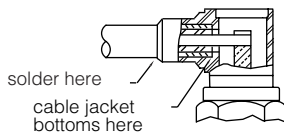

**Step 2** Assemble cable into connector body. Bottom cable in connector body as shown. Solder cable to connector body as shown.

### Step 3

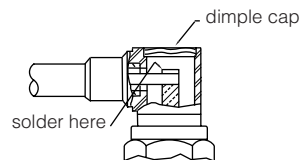

**Step 3** Solder center conductor to contact as shown. Remove excess solder. Assemble cap and solder or lightly punch center of cap for retention in body.

### RIGHT ANGLE PLUGS & CRIMP TYPE

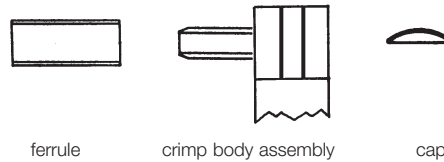

Amphenol Number	Connector Type	Cable RG-/U	Hex Cavity for Outer Ferrule	Die Set for Tool Handle 227-944	Stripping Dimensions, Inches (mm)		
					a	b	c
919-104P-51AX	50μ MCX Angle Plug	174, 188, 316	.128 (3.25)	CTL -13	.337	.133	.106
919-104P-51A1X	50μ MCX Angle Plug	174, 188, 316	.128 (3.25)	CTL -13	.337	.133	.106
919-122P-51AX	50μ MCX Angle Plug	174, 188, 316	.105 (2.67)	CTL -13	.337	.133	.106
919-136P-51AX	75μ MCX Angle Plug	174, 188, 316	.128 (3.25)	CTL -13	.337	.133	.106
919-136P-51A2X	75μ MCX Angle Plug	174, 188, 316	.151 (3.84)	CTL -13	.337	.133	.106

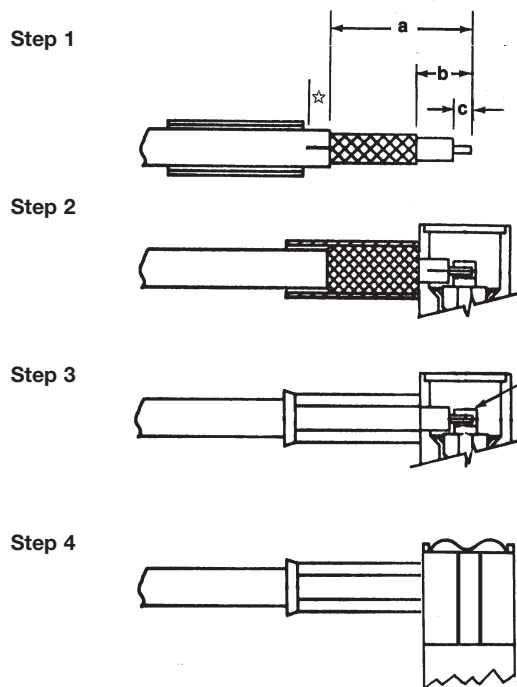

**Step 1** Slide ferrule over cable. Trim cable to dimensions shown in table above. Tin center conductor. Make 2 slits in jacket .062"(1.6mm) long, 180° apart.

**Step 2** Insert cable into back end of crimp body assembly as shown. Center conductor will enter slot in contact. Slide ferrule over braid and crimp using hex die shown in table above.

**Step 3** Solder center conductor into contact.

**Step 4** Insert cap into body and dimple or lightly punch center of cap for retention in body.



### STRAIGHT CONNECTOR FOR SEMI-RIGID CABLE

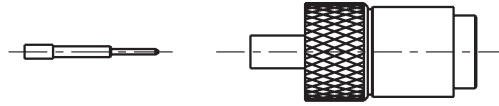

Amphenol Number	Connector Type	Cable RG-/U	Stripping Dims., inches (mm)	
			a	c
102-799-41	1.0/2.3	S/R .141	.079 (2.00)	.118 (3.0)
102-799-85	1.0/2.3	S/R .085	.079 (2.00)	.118 (3.0)
102-243-41	1.0/2.3	S/R .141	.085 (2.16)	-----
102-246-41	1.0/2.3	S/R .141	.080 (2.03)	.120 (3.05)
102-246-85	1.0/2.3	S/R .085	.080 (2.03)	.120 (3.05)

Step 1

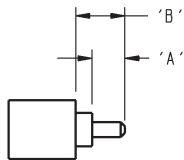

**Step 1** Prepare cable according to diagram. Remove burs from outer/inner conductors of cable.

Step 2

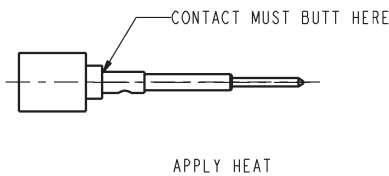

**Step 2** Solder center contact to inner conductor of cable using Sn60 solder. Contact must butt on dielectric of cable as shown.

Step 3

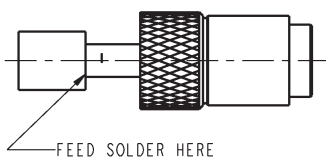

**Step 3** Insert contact into body assembly as shown. Holding body and cable firmly, apply heat as shown and feed solder (Sn60) as indicated. Allow to cool.

### STRAIGHT CONNECTOR FOR FLEXIBLE CABLE

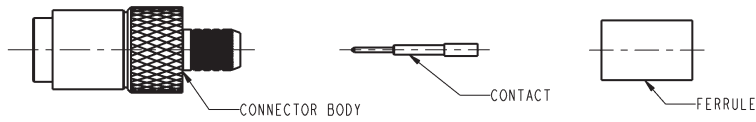

Amphenol Number	Connector Type	Cable RG-/U	Strip Dimensions, inches (mm)			Hex Crimp Data	
			a	b	c	Cavity for Outer Ferrule	CTL Series Tool No.
102-799-04	1.0/2.3 PLUG	58	.098 (2.49)	.198 (5.03)	.413 (10.5)	.213 (5.4)	CTL-1
102-799-04DB	1.0/2.3 PLUG	55, 142, 223	.098 (2.49)	.198 (5.03)	.413 (10.5)	.213 (5.4)	CTL-1
102-799-16	1.0/2.3 PLUG	174, 188, 316	.118 (3.0)	.243 (6.17)	.459 (11.65)	.128 (3.3)	CTL-13
102-799-16DB	1.0/2.3 PLUG	RD 316	.118 (3.0)	.243 (6.17)	.459 (11.65)	.151 (3.83)	CTL-13
102-799-20	1.0/2.3 PLUG	LMR 200	.098 (2.49)	.198 (5.03)	.413 (10.5)	.213 9(5.4)	CTL-1
102-799-48	1.0/2.3 PLUG	LMR 240	.098 (2.49)	.198 (5.03)	.413 (10.5)	.255 (6.5)	CTL-6
102-920-06	1.0/2.3 PLUG	174, 188, 316	.078 (2.0)	.216 (5.5)	.432 (LL.0)	.128 (3.3)	CTL-13

Step 1

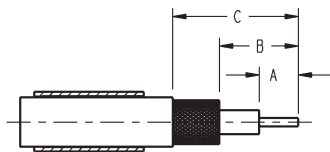

**Step 1** prepare cable according to diagram. Do not damage braid and inner conductor of cable. Slide crimp ferrule over the braid.

Step 2

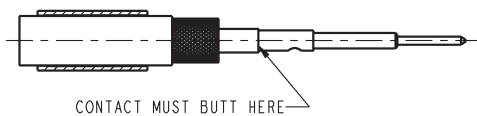

**Step 2** Solder contact to the center conductor of the cable. Contact must butt on the dielectric of cable as shown.

Step 3

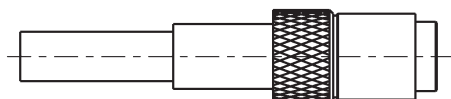

**Step 3** Flare braid and insert contact into body assembly. Contact must bottom in insulator. Crimp ferrule using the appropriate hex dies.

### RIGHT ANGLE CONNECTOR FOR FLEXIBLE CABLE

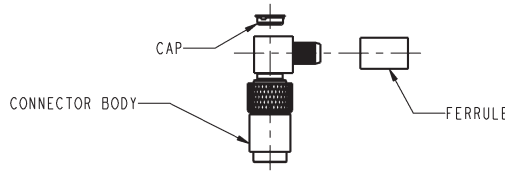

Amphenol Number	Connector Type	Cable RG-/U	Strip Dimensions, inches (mm)			Hex Crimp Data	
			a	b	c	Cavity for Outer Ferrule	CTL Series Tool No.
<b>102-799-104</b>	1.0/2.3 ANGLE PLUG	58	.098 (2.48)	.198 (5.02)	.414 (10.5)	.213 (5.4)	CTL-1
<b>102-799-104DB</b>	1.0/2.3 ANGLE PLUG	55, 142, 223	.098 (2.48)	.198 (5.02)	.414 (10.5)	.213 (5.4)	CTL-1
<b>102-799-116DB</b>	1.0/2.3 ANGLE PLUG	RD 316	.098 (2.48)	.198 (5.02)	.414 (10.5)	.151 (3.83)	CTL-13
<b>102-799-118</b>	1.0/2.3 ANGLE PLUG	MINI-COAX.	.078 (2.0)	.216 (5.5)	.432 (11.0)	.105 (2.67)	SX 660 0060
<b>102-799-120</b>	1.0/2.3 ANGLE PLUG	LMR200	.098 (2.48)	.198 (5.02)	.414 (10.5)	.213 (5.4)	CTL-1
<b>102-799-116</b>	1.0/2.3 ANGLE PLUG	174, 188, 316	.098 (2.48)	.198 (5.02)	.414 (10.5)	.128 (3.3)	CTL-13
<b>102-907-06</b>	1.0/2.3 ANGLE JACK	174, 188, 316	.078 (2.0)	.216 (5.5)	.432 (11.0)	.128 (3.3)	CTL-13
<b>102-907-34</b>	1.0/2.3 ANGLE JACK	L910/34, RG180	.078 (2.0)	.216 (5.5)	.432 (11.0)	.213 (5.4)	CTL-1

Assembly

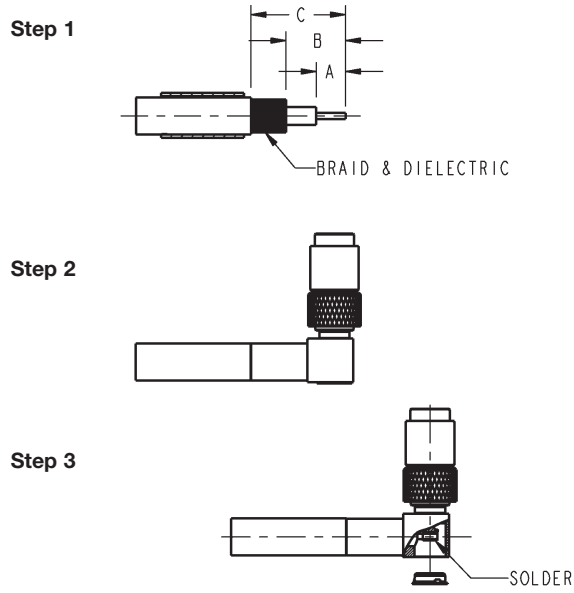

- Step 1** Prepare cable according to diagram. Do not damage braid and inner conductor of cable. Slide crimp ferrule over the braid
- Step 2** Flare braid and insert into body. Slide crimp ferrule over body and crimp the ferrule using appropriate crimp tool and die set.
- Step 3** solder inner conductor to contact (Sn60 recommended). Place cap on rear opening of body. Press cap into housing.

## STRAIGHT JACKS FOR FLEXIBLE CABLE

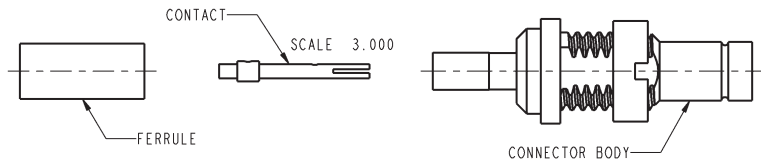

Amphenol Number	Connector Type	Cable RG-/U	Strip Dimensions, inches (mm)			Hex Crimp Data	
			a	b	c	Cavity for Outer Ferrule	CTL Series Tool No.
102-913-06	1.0/2.3 JACK	174, 188, 316	.078 (2.0)	.216 (5.5)	.432 (11.0)	.128 (3.3)	CTL-13
102-913-18	1.0/2.3 JACK	MINI-COAX	.078 (2.0)	.216 (5.5)	.432 (11.0)	.105 (2.67)	SX 660 0060
102-913-06DB	1.0/2.3 JACK	RD 316	.078 (2.0)	.216 (5.5)	.432 (11.0)	.151 (3.83)	CTL-13

Step 1

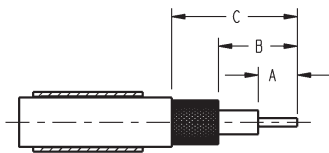

**Step 1** Prepare cable according to diagram. Do not damage braid and inner conductor of cable. Slide crimp ferrule over the braid.

Step 2

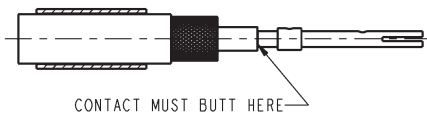

**Step 2** Solder contact to the center conductor of the cable. Contact must butt on the dielectric of cable as shown.

Step 3

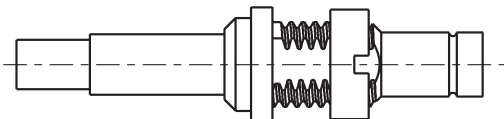

**Step 3** Flare braid and insert contact into body assembly. Contact must bottom in insulator. Crimp ferrule using the appropriate hex dies.

### RIGHT ANGLE JACKS FOR SEMI-RIGID CABLE

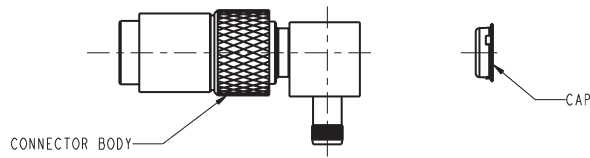

Amphenol Number	Connector Type	Cable RG-/U	Stripping Dims., inches (mm)	
			a	c
102-799-85	1.0/2.3 JACK	S/R .085	.098 (2.48)	.198 (5.02)
102-799-141	1.0/2.3 JACK	S/R .141	.098 (2.48)	.198 (5.02)

Step 1

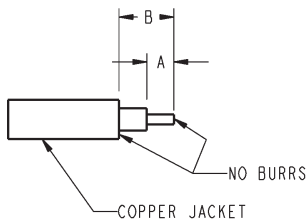

**Step 1** Prepare cable as shown. Remove burrs from outer/inner conductors of cable.

Step 2

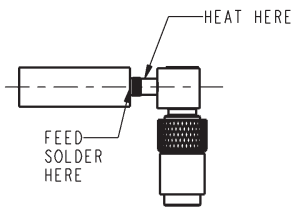

**Step 2** Insert cable into connector until it bottoms on shoulder of body. Solder outer conductor (Sn60) recommended.

Step 3

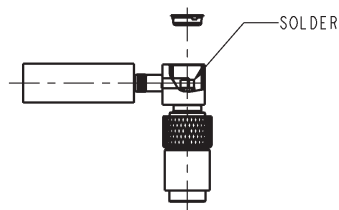

**Step 3** Solder inner conductor to contact (Sn-60 recommended). Place cover on rear opening of body. Press cap into housing.





**A****AMPS**

Advanced Mobile Phone System, an analog standard for wireless service.

**Accessories**

Mechanical devices, such as cable clamps, added to connector shells and other such hardware which is attachable to connectors to make up the total connector configuration.

**A/D**

Analog-to-digital.

**Alloy**

A mixture of two or more metals combined to achieve properties, such as a lower melting point or greater strength, that the individual metals do not possess.

**Ambient**

The atmospheric conditions surrounding a given item. Normally in terms of factors which influence or modify, such as temperature, humidity, etc.

**Amplitude**

The magnitude of variation in a changing quantity from its zero value. The word required modification - as with adjectives such as peak, maximum, rms, etc. - to designate the specific amplitude in question.

**Analog**

The representation of information by means of continuously variable signal.

**Attenuation (a)**

The decrease of a signal with the distance in the direction of propagation. Attenuation may be expressed as the scalar ratio of the input power to the output power, or as the ratio of the input signal voltage to the output signal voltage.

**B****Back Mounted (rear mounting)**

When a connector is mounted from the inside of a panel or box with its mounting flange inside the equipment.

**Backplane Panels**

An interconnection panel into which PCB cards or other panels can be plugged. These panels come in a variety of designs ranging from a PC motherboard to individual connectors mounted in a metal frame. Panels lend themselves to automated wiring.

**Bandwidth**

The range of frequencies for which performance falls within specific limits.

**Barrier Seal**

A barrier seal is a seal preventing the passage of moisture or gases through the insulator and the gap between insulator and center conductor or outer conductor of a connector or adapter.

**Base Material**

Metal from which the connector, contact or other piece part accessory is made and on which one or more metals or coatings may be deposited.

**Bayonet Coupling**

A quick coupling device for plug and receptacle connectors, accomplished by rotation of a cam operating device designed to bring the connector halves together.

**B-CDMA**

Broadband - Code Division Multiple Access (CDMA)

**Bending Radius**

The minimum permissible radius for fixed installation of the cable. This

radius is mainly used in climatic tests.

Minimum dynamic: The minimum permissible radius for flexible applications of the cable.

**BNC (Bayonet Neill Concelman)**

Coaxial connector with bayonet coupling mechanism. Available in 50 Ohm and 75 Ohm versions. Frequency range DC - 4 GHz (50 Ohm) and DC-1 GHz (75 Ohm), respectively. Named after Amphenol Engineer Carl Concelman, and Bell Labs Engineer Paul Neill.

**Body**

Main, or largest, portion of a connector to which other portions are attached.

**Bonded Assembly**

A connector assembly in which the components are bonded together using an electrically appropriate adhesive in a sandwich structure to provide sealing against moisture.

**Braid**

Woven wire used as shielding for insulated wires and coaxial cables. Also, a woven fibrous protective outer covering over a conductor or cable.

**Braid Coverage**

A calculated percentage which defines the completeness with which a braid or shield covers the surface of the underlying component.

**Bulkhead**

A term used to define a mounting style of connectors. Bulkhead connectors are designed to be inserted into a panel cutout from the rear (component side) or front side of the panel.



**Butted Contact**

When two conductors come together end-to-end, but do not overlap, with their axis in line.

**C****CATV**

Cable television (previously community antenna television) technology, commonly employed by broadband LANs for signal distribution.

**Cable Assembly**

A completed cable and its associated hardware (e.g. connector).

**Capacitance**

The property of an electrical conductor (dielectric in a capacitor) that permits the storage of energy as a result of electrical displacement. The basic unit of capacitance is the Farad, however measurement is more commonly in microfarads or picofarads.

**Capillary Actions**

The effect of surface tension that draws a liquid into a small opening.

**CDMA (IS-95)**

Code Division Multiple Access, a digital standard for wireless service.

**Closed Entry Contact**

A specially designed connector interface which controls the entry of the male pin from damaging the female contact.

**Coaxial Cable**

A transmission line consisting of two concentric conductors insulated from each other. In its flexible form it consists of either a solid or stranded center conductor surrounded by a dielectric. A braid is then woven

over the dielectric to form an outer conductor. A protective plastic covering is placed on top of the braid.

**Concelman**

Amphenol Engineer after which many coaxial connectors are named: C, BNC, TNC, etc.

**Connector Assembly**

Includes housing and contact plus additional components such as hardware used to hold the assembly together and/or make the assembly a functional connector.

**Contact**

The conducting part of an interconnect at the interface between the connector and the lead on the device being connected.

**Contact Alignment**

Defines the overall radial play which contacts shall have within the insert cavity so as to permit self-alignment of mated contacts. Sometimes referred to as amount of contact float.

**Contact Cavity**

A defined hole in the connector insert or housing into which the contact must fit.

**Contact Durability**

The number of insertion and withdrawal cycles that a connector must be capable of withstanding while remaining within the performance levels of the applicable specification.

**Contact Engaging & Separating Force**

Force needed to either engage or separate pins and socket contacts

when they are in and out of connector inserts. Values are generally established for maximum and minimum forces. Performance acceptance levels vary by specification and/or customer requirements.

**Contact Plating**

Deposited metal applied to the basic contact metal to provide the required contact-resistance and/or wear-resistance.

**Contact Pressure**

Force which mating surfaces exert against one another.

**Contact Resistance**

Measurement of electrical resistance of mated contacts when assembled in a connector under typical service use. Electrical resistance is determined by measuring from the rear of the electrical area of one contact to the rear of the mating contact (excluding both crimps) while carrying a specified test current.

**Contact Retention**

Defines minimum axial load in either direction which a contact must withstand while remaining firmly fixed in its normal position within an insert.

**Convection**

The transfer of heat by movement of hot air. Often used in conjunction with infrared radiation to reduce the effect of IR shadowing.

**Coplanarity**

The distance between the lowest and highest lead when the connector is laying in its seating plane.

**Corona**

A luminous discharge due to ionization of the air surrounding a conductor caused by a voltage gradient exceeding a certain critical value.

**Crimp**

Act of compressing (deforming) a connector ferrule around a cable in order to make an electrical connection.

**Crimping Dies**

A term used to identify the shaping tools that, when moved toward each other, produce a certain desirable shape to the barrel of the terminal or contact that has been placed between them. Crimping dies are often referred to as die sets or as die inserts.

**Crimping Termination**

Connection in which a metal sleeve is secured to a conductor by mechanically crimping the sleeve with pliers, presses or crimp dies.

**Crimping Tool**

A term commonly used to identify a hand held mechanical device or table press that is used to crimp a contact, terminal or splice.

**Cross Talk**

A magnetic or electrostatic coupling which causes the unwanted transfer of energy from one circuit (disturbing circuit) to another circuit (disturbed circuit).

**CTIA**

Cellular Telecommunications Industry Association.

**Cut-off Frequency (fc)**

The frequency, above which other than the TEM mode may occur. The transmission characteristics of cables

above their cutoff frequency may be unstable.

**Cycle**

One complete sequence of values of an alternating quantity, including a rise to maximum in one direction and of return to zero. The number of cycles occurring in one second is called the frequency.

**D****D/A**

Digital-to-analog

**dBm**

Relative measure of signal power where the reference 0 dBm is equal to one milliwatt. See also decibel.

**Decibel (dB)**

A relative unit without dimensions calculated as ten times the logarithm to the base 10 of a power ratio or as twenty times the logarithm to the base 10 of a voltage ratio.

Note: What is commonly measured as VSWR in the RF world is referred to as return loss and measured in dB in the CATV industry.

**Delay Line**

A cable that delays electrical signals by a specified amount of time.

**Dewetting**

A situation where a lead or pad was at one point in the soldering process wetted by the solder, but due to extended time or temperature, the presence of intermetallics, volatiles or other causes, has become withdrawn from the wetted surface.

**Dielectric**

In a coaxial cable, the insulation between inner and outer conductor.

It significantly influences electrical characteristics such as impedance, capacitance, and velocity of propagation.

**Dielectric Constant**

Electrical property of a material that describes its behavior in an electric field. The dielectric constant of the dielectric is the most important design parameter for coaxial cables and determines dimensions, losses and propagation characteristics.

**Dielectric Loss**

In a coaxial cable, the losses caused by transformation of electromagnetic energy into heat within the dielectric material.

**Dielectric Strength**

The voltage which an insulating material can withstand before breakdown occurs.

**Dielectric Withstanding Voltage**

The maximum potential gradient that a dielectric material can withstand without failure.

**Digital**

(1) Pertaining to the utilization of discreet integral numbers in a given base to represent all the quantities that occur in a problem or a calculation. It is possible to express in digital form all information stores, transferred or processed by a dual-state condition; e.g., on-off, open-closed and true-false. (2) Compare with analog.

**DIN 7/16**

50  $\Omega$  coaxial connector with screw type coupling mechanism providing excellent intermodulation characteristics. Suitable for medium to high power applications. Frequency

range DC - 7.5 GHz.

### Dip Solder Terminal

The terminals on a connector which are inserted into holes in the PC board and then soldered in place.

### Direct Current (DC)

An electric current which flows in only one direction.

### Dissipation

Unusable or lost energy, such as the production of unused heat in a circuit.

### Distortion

An unwanted change or addition to a signal or waveform when it is amplified. This definition excludes noise which is an extraneous signal super-imposed on the desired signal.

### Dummy Load

A dissipative device used at the end of a transmission line or waveguide to convert transmitted energy into heat, so essentially no energy is radiated outward or reflected back to its source.

### Dust Cap

A device attached to a connector to provide protection against dust and foreign debris.

## E

### Eccentricity

A measure of a conductor's location with respect to the circular cross section of the insulation. Expressed as a percentage of center displacement of one circle within the other.

### EIA

Electronic Industries Association.

### Electromagnetic Compatibility (EMC)

EMC describes the ability of an electrical system to avoid electromagnetic interference with the environment.

### Electromagnetic Interference (EMI)

Unwanted electrical or electromagnetic energy that causes undesirable responses, degrading performance or complete malfunctions in electronic equipment. See also: Noise.

### Electronic Industries Association (EIA)

A U.S. manufacturer's group which, as one of its functions, sets some interface standards.

### Electroplating

A method of electrically depositing metals of very precise compositions and thickness onto a base metal.

### Ethernet

(1) In a local computer network, a branching broadcast communications system for carrying digital data packets among locally distributed computing stations. (2) A two-level, baseband, local-area data communications network developed by Xerox and supported by DEC and Intel, among others.

### Eutectic Solder

The most common solder alloy because of its low melting point (183°C/361°F), composed of 63% tin and 37% lead.

## F

### FCC

Federal Communications Commission.

### Feed-through

A connector or terminal block, usually having double-ended terminals which permits simple distribution and bussing of electrical circuits. Also used to describe a bushing in a wall or bulkhead separating compartments at different pressure levels, with terminations on both sides.

### Ferrule

A short tube to make solderless connections to shielded or coaxial cable (e.g. as in crimping).

### Fiber Optics

The technology for guidance of light waves through optical fibers; specifically when the optical energy is guided to another location in order to transmit information.

### Flange

A projection extending from, or around the periphery of, a connector and provided with holes to permit mounting the connector to a panel, or to another mating connector half.

### Footprint

The pattern on the printed circuit board to which the leads on a surface mount component are mated. Also called a land or a pad.

### Frequency Modulation (fm)

A scheme for modulating a carrier frequency in which the amplitude remains constant but the carrier frequency is displaced in frequency proportionally to the amplitude of the modulating signal. An fm broadcast is practically immune to atmospheric and man-made interference.

### Fretting Corrosion

A form of accelerated oxidation that

appears at the interface of contacting materials undergoing slight cyclic relative motion. All non-noble metals (tin) are susceptible to some degree of fretting corrosion and will suffer contact resistance increases.

**Front Mounted (front mounting)**

A connector is front mounted when it is attached to the outside or mating side of a panel. A front mounted connector can only be installed or removed from the outside of the equipment.

**G****GHz**

See Gigahertz.

**Gigahertz (GHz)**

One billion cycles per second ( $1 \times 10^9$ ).

**GPS**

Global Positioning System

**GSM**

Global System for Mobile communication, a digital standard for wireless service for high-performance cell phones; European and de facto world standard.

**H****HDTV**

High-definition television.

**Heat Shock**

Test to determine the stability of a material when exposed to a sudden high temperature change for a short period of time.

**Heat Treating**

A process that uses precise heating and tooling of metals in order to optimize internal stresses and spring properties.

**Hermetic Seal**

Hermetically sealed connectors provide contacts bonded to the connector by glass. They permit maximum leakage rate of gas through the connector of 1.0 micron ft/hr at one atmosphere pressure for special applications.

**Hermaphroditic Connector**

A connector where both mating members are exactly alike at their mating face. There are no male or female members, but provisions have been made to maintain correct polarity, hot lead protection, sealing and coupling.

**Hermaphroditic Contacts**

Contacts in which both mating elements are precisely alike at their mating face.

**Hertz (Hz)**

International standard term for cycles per second. Named after the German physicist Heinrich R. Hertz (e.g. 60 cycles per second is equal to 60 hertz or 60 Hz).

**I****IEEE**

Institute of Electrical and Electronics Engineers.

**IM/PIM (Passive Intermodulation)**

The generation of new (and in the case of cable assemblies undesirable) signals (intermodulation products) at the non-linear characteristics of transmission elements.

**Impedance (characteristic, Z<sub>0</sub>)**

Characteristic property of a transmission line describing the ratio between electric and magnetic fields.

**Impedance Match**

A condition in which the impedance of a component or circuit is equal to the internal impedance of a transmission line. This gives maximum transfer of energy from the source to the load, as well as minimum reflection and distortion.

**Inductance**

The property of a circuit or circuit element that opposes a change in current flow, thus causing current changes to lag behind voltage changes. It is measured in Henrys.

**Insert**

The part which holds the contacts in their proper arrangement and electrically insulates them from each other and from the shell.

**Insertion Loss**

The loss in load power due to the insertion of a component, connector or device at some point in a RF transmission system. Generally expressed in decibels as the ratio of the power received at the load before insertion of the apparatus, to the power received at the load after insertion (for more information please refer to Appendix).

**Insulation**

A material having high resistance to the flow of electric current. Often called a dielectric in RF cable.

**Insulation Resistance**

The electrical resistance of the insulating material (determined under specified conditions) between any pair of contacts, conductors, or grounding device in various combinations.

**Interconnection**

Mechanically joining assemblies together to complete electrical circuits.

**Interface**

The two surfaces on the contact side of both halves of a multiple-contact connector which face each other when the connector is assembled.

**Interference**

An electrical or electromagnetic disturbance that causes undesirable response in electronic equipment.

**Intermetallic**

Chemical compounds formed between the metals present in the solder, base metal and protective plating. Intermetallic formation is necessary for good solder joints, but excessive intermetallics can cause brittleness.

**Intermodulation (IMD)**

A phenomenon that occurs when two or more fundamental frequencies are present in an electronic circuit.

**IR Shadowing**

When connector bodies or other components prevent the infrared energy from directly striking some solder joints, causing non-uniform heating.

**ISO**

International Standards Organization.

**J****Jack**

A connecting device into which a plug can be inserted to make circuit connections. The jack may also have contacts which open or close to perform switching functions when

the plug is inserted or removed. See also: receptacle.

**Jacket**

An outer non-metallic protective cover applied over an insulated wire or cable.

**J-Lead**

A surface mount lead configuration where leads are bent into curves. Infrequently used on interconnects.

**L****LAN**

Local Area Network. A data communication network confined to a limited geographic area (up to 6 miles or about 10 kilometers).

**Land**

The metal portion of a printed circuit board where the pads on a surface mount component are mated. Also called a footprint or a pad.

**Levels of Interconnection**

Device to board or chassis. The connection point between components (tubes, transistors, IC packages) and the PC board or chassis.

Board to motherboard or backplane. The connection point between PC boards or sub-circuit modules and the motherboard or a backplane Board.

Backplane wiring. Connections between levels to each other and to other sub-circuits.

Input/output. Connections for power and signals into and out of a system. Connections may be between subassemblies within the same enclosure or between individual units.

**Line Impedance**

Impedance as measured across the terminals of a transmission line; frequently the characteristic impedance of the line.

**Low Noise Cable**

Cable specially constructed to avoid spurious electrical disturbances caused by mechanical movements.

**M****Mating Face Seal**

A mating face seal is a seal preventing the passage of moisture or gases into or out of the connecting interface of two connectors in mated condition.

**MCX (Micro coaxial)**

Micro coaxial connector with snap on coupling mechanism. Available in 50 ohm and 75 ohm versions. Frequency range DC - 6 GHz.

**MHV (Miniature High Voltage)**

Coaxial connector with bayonet coupling mechanism. Working voltage 2.2 kV DC.

**Microstrip**

A type of transmission line configuration which consists of a conductor over a parallel ground plane, and separately by a dielectric.

**Microwave**

That portion of the electromagnetic spectrum lying between the far infrared and conventional radio frequency range. The microwave frequency range extends from 1 GHz to 300 GHz. Microwaves are usually used in point-to-point communications because they are easily concentrated into a beam.

**MIL**

Military (e.g. as in Military Standards).

**Mismatch (Connector Impedance or Line Impedance)**

The condition in which the impedance of a source does not match or equal the impedance of the connected load. This reduces power transfer by causing reflection.

**MMCX**

Miniature Microcoax connector with snap on coupling mechanism. Available in 50 ohm and 75 ohm versions. Frequency range DC - 6 GHz.

**Moisture Resistance**

The ability of a material to resist absorbing moisture from the air or when immersed in water.

**Motherboard**

A printed board used for interconnecting arrays of plug-in electronic modules.

**N****N (Neill)**

Coaxial connector with screw type coupling mechanism. Available in 50 ohm and 75 ohm version. Frequency range DC - 18 GHz (50 ohm) and DC-1 GHz (75 ohm), respectively.

**NAB**

National Association of Broadcasters

**Noise**

Random electrical signals, generated by circuit components or by natural disturbances.

**O****OEM**

Original Equipment Manufacturer.

**Ohm**

The unit of measurement for electrical

resistance. A circuit is said to have a resistance of one ohm when an applied emf of one volt causes a current of one ampere to flow.

**P****Pad**

The metal portion of a printed circuit board where the leads on a surface mount component are mated. Also called a footprint or a land.

**Panel Seal**

A panel seal is a seal preventing the passage of moisture or gases through the gap between the mounting hole of the panel and the connector body of the fixed connector.

**PC**

Personal Computer.

**Permeability (magnetic)**

The measure of how much better a material is than air as a path for magnetic lines of force. Air is assumed to have a permeability of 1.

**Permittivity Relative**

Synonym term for relative dielectric constant  $\epsilon_r$ .

**Phase Shift**

Change in phase of a voltage or current after passing through a circuit or cable.

**Phase Stability**

Variation of the electrical length of a cable that can result from temperature or mechanical stress due to bending or torsion.

**Pin Contact**

A male type contact, usually designed to mate with a socket or female contact. It is normally connected to

the "dead" side of a circuit.

**Plated Through-Hole**

A hole through a printed circuit board that has been electroplated and into which a lead is placed and soldered for electrical and mechanical connection.

**Plug**

In coaxial RF connectors the plug is usually the movable portion, and is usually attached to a cable or removable assembly. Plugs mate with receptacles, jacks, outlets, etc.

**Press-Fit Contact**

An electrical contact which can be pressed into a hole in an insulator, printed board (with or without plated-through holes), or a metal plate.

**Printed Circuit Board (PCB)**

An epoxy glass and metal composite on which circuits are etched and to which active, passive and hardware components are attached. Also called PCB or PC Board.

**Propagation Delay**

Time required for an electronic digital device, or transmission network to transfer information from its input to its output.

**Prototype**

A model suitable for use in the complete evaluation of form, design and performance.

**PTFE (polytetrafluoroethylene)**

The thermally most stable and chemically most resistant carbonaceous compound. It is unaffected by sunlight, moisture, and virtually all chemicals. Temperature range is -200°C to +260°C / -392°F to +500°F. Electrical properties are very constant over

temperature and wide range of frequencies.

### **Pulse**

A change in the level, over a relatively short period of time, of a signal whose value is normally constant.

### **Pulse Width**

The length of time that the pulse voltage is at the transient level. Electronic pulse widths are usually in the millisecond (10<sup>-3</sup>), microsecond (10<sup>-6</sup>) or nanosecond (10<sup>-9</sup>) range.

## **R**

### **Range**

Number of sizes of connectors or cables of a particular type.

### **Receptacle**

Usually the fixed or stationary half of a two-piece multiple contact connector. Also the connector half usually mounted on a panel and containing socket (female) contacts.

### **Reflection**

See VSWR.

### **Reflection Loss**

The part of a signal which is lost due to reflection of power at a line discontinuity.

### **Reflow Soldering**

The process of screen printing solder paste and then heating it to cause it to melt, or "reflow", to wet the leads and pads around it.

## **RF**

Radio frequency.

## **RG/U**

Symbol used to designate coaxial cables that are made to government

specification (e.g., RG-58U; in this designation the "R" means radio frequency, the "G" means government, the "58" is the number assigned to the government approval, and the "U" means it is an universal specification).

### **Rise Time**

The time required for a component or logic circuit to change from the quiescent to the transient state when an output is applied, (e.g. elapsed time between application of input and attainment of full output level).

## **RMS**

Root mean square.

### **Root Mean Square**

The effective value of an alternating current, corresponding to the direct current value that will produce the same heating effect.

## **S**

### **SC (Concelman, Amphenol Engineer)**

Threaded connector 0 to 11 GHz.

### **Screening Effectiveness**

Ratio of the power fed into a coaxial cable to the power transmitted by the cable through the outer conductor.

### **Screw Machine Contact**

A contact which is machined from solid bar stock.

### **Self-Align**

Design of two mating parts so that they will engage in the proper relative position.

### **Self Alignment**

The tendency of leads to center themselves on solder pads due to the surface tension of the liquid solder.

## **Semi-Rigid**

A cable containing a flexible inner core and a relatively inflexible sheathing.

## **Shield**

(1) A conducting housing or screen that substantially reduces the effect of electric or magnetic fields on one side thereof, upon devices or circuits on the other side. Cable shields may be solid, braided, or taped (longitudinally or spirally). (2) In cables, a metallic layer placed around a conductor or group of conductors to prevent electrostatic or electromagnetic interference between the enclosed wires and external fields.

## **Shielding**

The metal sleeve surrounding one or more of the conductors, in a wire circuit to prevent interference, interaction or current leakage.

## **Shock (mechanical)**

(1) An abrupt impact applied to a stationary object. (2) An abrupt or non-periodic change in position, characterized by suddenness, and by the development of substantial internal forces.

## **SHV (Safe High Voltage)**

Coaxial connector with bayonet coupling mechanism. Working voltage 5 kV DC.

## **Skin Effect**

The phenomenon wherein the depth of penetration of electric currents into a conductor decreases as the frequency of the current increases.

## **SMA (Subminiature A)**

50 ohm - subminiature coaxial connector with screw type coupling mechanism. Frequency range DC-18 GHz.

**SMB (Subminiature B)**

Subminiature coaxial connector with snap-on coupling mechanism. Frequency range DC - 4 GHz.

**SMC (Subminiature C)**

Subminiature coaxial connector with screw type coupling mechanism. Frequency range DC - 10 GHz.

**SMS**

Subminiature coaxial connector with slide-on coupling mechanism. Frequency range DC - 4 GHz.

**Snap on**

Used to describe the easy removal or assembly of one part to another. A connector containing socket (female) contacts into which a plug connector having male contacts is inserted.

**Solder Contact**

A contact or terminal with a cup, hollow cylinder, eyelet or hood to accept a wire for a conventional soldered termination.

**Spring-Finger Action**

Design of a contact, as used in a printed circuit connector or a socket contact, permitting easy, stress-free spring action to provide contact pressure and/or retention.

**Standing-Wave**

Distribution of current and voltage on a transmission line, resulting from two sets of waves traveling in opposite directions.

**Standing Wave Ratio**

A measure of the mismatch between the load the line. It is equal to 1 when the line impedance is perfectly matched to the load. (In which case the maximum and minimum are the

same, as current and voltage do not vary along the line). The perfect match would be a 1 to 1 ratio.

**Stripline**

A type of transmission line configuration which consists of a single narrow conductor parallel and equidistant to two parallel ground planes.

**Surface Mount Device (SMD)**

An active or passive device designed to be soldered to the surface of the printed circuit board.

**Surface Mount Technology(SMT)**

The process of assembling printed circuit boards with components soldered to the surface rather than fastened to printed circuit board through-holes.

**SWR**

Standing Wave Ratio.

**T****TDMA**

Time Division Multiple Access, a digital standard primarily used in Asia and Europe.

**Thermal Shock**

The effect of heat or cold applied at such a range that non-uniform thermal expansion or contraction occurs within a given material or combination materials. The effect can cause inserts and other insulation materials to pull away from metal parts.

**Third Generation (3G)**

The next generation in wireless producing a convergence of standards and services.

**TNC (Threaded Neill Concelman)**

Coaxial connector with screw type

coupling mechanism. Available in 50 ohm and 75 ohm versions. Frequency range DC - 11 GHz (50 ohm) and DC - 1 GHz (75 ohm), respectively.

**Transmission Line**

A signal-carrying circuit composed of conductors and dielectric material with controlled electrical characteristics used for the transmission of high-frequency, narrow-pulse type signals.

**Transmission Loss**

The decrease of loss in power during transmission of energy from one point or another. Usually expressed in decibels.

**Triaxial Cable**

A cable consisting of one center conductor and two outer concentric conductors (with an insulating layer separating them). Notable for increased shielding efficiency.

**Twinaxial Cable**

Two conductors that are insulated from one another, twisted together and surrounded by a common shield.

**U****UG**

Symbol used to describe coaxial connectors that were made to a government specification. This specification is now obsolete.

**UHF**

Coaxial connector with screw type coupling mechanism invented in the 1930's by Amphenol engineer E. Clark Quackenbush for use in the radio industry. Non-defined impedance. Frequency range DC.

**Ultra High Frequency (UHF)**

A Federal Communications



Commission designation for the band from 300 MHz to 3,000 MHz (3GHz) on the radio spectrum.

**UMTS**

Universal Mobile Telecommunications Systems.

**V****Very High Frequency (VHF)**

A Federal Communications Commission designation for the band from 30 to 300 MHz on the radio spectrum.

**Velocity of Propagation**

The speed of an electrical signal down a length of cable compared to speed in free space expressed as a percentage.

**Voltage**

The term most often used to designate electrical pressure that exists between two points and is capable of producing a flow of current when a closed circuit is connected between the two points. Voltage is measured in volts, millivolts, microvolts and kilovolts. The terms electromotive force (emf), potential, potential difference and voltage drop are often referred to as voltage.

**Voltage Standing Wave Ratio (VSWR)**

A measure of the reflection, resulting from a ratio of the input signal to the reflected signal.

$$\text{VSWR} = (1+L) / (1-L)$$

**VSWR**

See Voltage Standing Wave Ratio and Standing Wave Ratio.

**W****Wavelength**

The distance, measured in the direction of propagation, of a repetitive electrical pulse or waveform between two successive points that are characterized by the same phase of vibration.

**Wave Soldering**

The most widely used mass soldering process, primarily for through-hole boards, where the board is passed over a wave of solder which laps against the bottom of the board to wet the metal surfaces to be joined.

**W-CDMA**

Wideband-Code Division Multiple Access (CDMA).

**Wetting**

The ability of liquid solder to attach itself to the surfaces being joined through the formation of intermetallic bonds.

**Wiping Action**

The action which occurs when contacts are mated with a sliding action. Wiping has the effect of removing small amounts of contamination from the contact surfaces, thus establishing better conductivity.

**WLAN**

Wireless Local Area Network.

**WLL**

Wireless Local Loop.





---

## Index

Plating Codes	362
Insulator/Dielectric Codes	362
VSWR vs Return Loss	363
Part Number Index	364-372
Cable Assembly Index	373-377
Other Division Catalogs	378-379

---

# Index

## Plating and Insulator/Dielectric Codes

### Plating Codes

Plating Code	Body	Contact
P1	Nickel	Silver
P2	Nickel	Nickel
P3	Nickel	—
P4	Silver	Silver
P5	Nickel	Tin-Lead
P6	Tin-Lead	Gold
P7	Nickel	Contacts: Gold Terminals: Silver Legs: Tin-Lead
P8	—	Tin Dip
P9	Gold over Copper	Gold over Copper
P10	Gold over Copper	Gold over Nickel
P11	Gold over Nickel	Gold over Nickel
P12	Passivated	Gold over Copper
P13	Passivated	Gold over Nickel
P14	Gold over Copper	—
P15	Nickel	Gold over Nickel
P16	Body: Gold over Nickel Cube & Legs: Tin-Lead	Gold over Nickel
P17	Nickel	Gold over Copper
P22	Nickel over Copper	Center Contact: Gold over Nickel Outer Contact: Nickel over Copper
P26	Nickel over Copper (Black Epoxy) Legs: Tin over Nickel	Gold over Copper (Tin-Plated Terminals)
P27	—	Silver
P28	Nickel	Contact: Gold over Copper Ground Tab: Silver
P29	B: Gold over Nickel over Copper N: Passivated	Gold over Nickel over Copper
P33	Silver	Gold over Nickel
P34	Silver	Gold over Copper
P35	Conductive Black UV Coat over Zinc	Gold over Nickel
P36	Tin-Lead	Tin-Lead
PCF	Consult Factory	
P37	Nickel	Inner: Gold Outer: Gold

### Insulator/Dielectric Codes

Ins. Code	Dielectric Material
D1	TFE or equiv. per MIL-P-19468A
D2	PBT Polyester, 30% glass reinforced MIL-P-46161 Grade A Class 3
D3	Diallyl Phthalate, MIL-M-14F, Type SDG
D4	Durez 16274 Phenolic
D5	Polystyrene
D6	Copolymer of Styrene, Type E-2 per MIL-P-77C
D9	PTFE per ASTM-D-1457
D11	Glass Pressure Seal
D12	Noryl GFN2 20% Glass filled
D14	Polypropylene
D15	20% Glass filled Polycarbonate/Polypropylene
D17	Valox Housing, Noryl Insulator
D19	Noryl GFN2 SE 1/Noryl HS2000
D20	Black Valox Housing, White Noryl Insulator
D22	Noryl SE-100-80283
D23	Delrin
D24	Phenolic
D25	PBT Polyester
D26	TPX
D30	LCP
D31	Valox
D32	Red TFE or equiv. per ASTM D1457
L1	Molded, Liquid Crystal Polymer

## VSWR vs. Return Loss (R)

VSWR	R dB	VSWR	R dB	VSWR	R dB	VSWR	R dB	VSWR	R dB
1.001	66.025	1.060	30.714	1.138	23.803	1.480	14.264	5.400	3.255
1.002	60.009	1.061	30.575	1.140	23.686	1.490	14.120	5.600	3.136
1.003	56.491	1.062	30.438	1.142	23.571	1.500	13.979	5.800	3.025
1.004	53.997	1.063	30.303	1.144	23.457	1.520	13.708	6.000	2.923
1.005	50.484	1.064	30.171	1.146	23.346	1.540	13.449	6.200	2.827
1.006	50.484	1.065	30.040	1.148	23.235	1.560	13.201	6.400	2.737
1.007	49.149	1.066	29.912	1.150	23.127	1.580	12.964	6.600	2.653
1.008	47.993	1.067	29.785	1.152	23.020	1.600	12.736	6.800	2.573
1.009	46.975	1.068	29.661	1.154	22.914	1.620	12.518	7.000	2.499
1.010	46.064	1.069	29.538	1.156	22.810	1.640	12.308	7.200	2.428
1.011	45.240	1.070	29.417	1.158	22.708	1.660	12.107	7.400	2.362
1.012	44.489	1.071	29.298	1.160	22.607	1.680	11.913	7.600	2.299
1.013	43.798	1.072	29.181	1.162	22.507	1.700	11.725	7.800	2.239
1.014	43.159	1.073	29.066	1.164	22.408	1.720	11.545	8.000	2.183
1.015	42.564	1.074	28.952	1.166	22.311	1.740	11.370	8.200	2.129
1.016	42.007	1.075	28.839	1.168	22.215	1.760	11.202	8.400	2.078
1.017	41.485	1.076	28.728	1.170	22.120	1.780	11.039	8.600	2.029
1.018	40.993	1.077	28.619	1.172	22.027	1.800	10.881	8.800	1.983
1.019	40.528	1.078	28.511	1.174	21.934	1.820	10.729	9.000	1.938
1.020	40.086	1.079	28.405	1.176	21.843	1.840	10.581	9.200	1.896
1.021	39.667	1.080	28.299	1.178	21.753	1.860	10.437	9.400	1.855
1.022	39.867	1.081	28.196	1.180	21.664	1.880	10.298	9.600	1.816
1.023	38.885	1.082	28.093	1.182	21.576	1.900	10.163	9.800	1.779
1.024	38.520	1.083	27.992	1.184	21.489	1.920	10.032	10.000	1.743
1.025	38.170	1.084	27.892	1.186	21.403	1.940	9.904	11.000	1.584
1.026	37.833	1.085	27.794	1.188	21.318	1.960	9.780	12.000	1.451
1.027	37.510	1.086	27.696	1.190	21.234	1.980	9.660	13.000	1.339
1.028	37.198	1.087	27.600	1.192	21.151	2.000	9.542	14.000	1.243
1.029	36.895	1.088	27.505	1.194	21.069	2.100	8.999	15.000	1.160
1.030	36.607	1.089	27.411	1.196	20.988	2.200	8.519	16.000	1.087
1.031	36.327	1.090	27.318	1.198	20.907	2.300	8.091	17.000	1.023
1.032	36.055	1.091	27.266	1.200	20.828	2.400	7.707	18.000	0.966
1.033	35.792	1.092	27.135	1.210	20.443	2.500	7.360	19.000	0.915
1.034	35.537	1.093	27.046	1.220	20.079	2.600	7.044	20.000	0.869
1.035	35.290	1.094	26.957	1.230	19.732	2.700	6.755	22.000	0.790
1.036	35.049	1.095	26.869	1.240	19.401	2.800	6.490	24.000	0.724
1.037	34.816	1.096	26.782	1.250	19.085	2.900	6.246	26.000	0.668
1.038	34.588	1.097	26.697	1.260	18.783	3.000	6.021	28.000	0.621
1.039	34.367	1.098	26.612	1.270	18.493	3.100	5.811	30.000	0.579
1.040	34.151	1.099	26.528	1.280	18.216	3.200	5.617	32.000	0.543
1.041	33.941	1.100	26.444	1.290	17.949	3.300	5.435	34.000	0.511
1.042	33.763	1.102	26.281	1.300	27.692	3.400	5.265	36.000	0.483
1.043	33.536	1.104	26.120	1.310	17.445	3.500	5.105	38.000	0.457
1.044	33.341	1.106	25.963	1.320	17.207	3.600	4.956	40.000	0.434
1.045	33.150	1.108	25.809	1.330	16.977	3.700	4.815	42.000	0.414
1.046	32.963	1.110	25.658	1.340	16.755	3.800	3.682	44.000	0.395
1.047	32.780	1.112	25.510	1.350	16.540	3.900	4.556	46.000	0.378
1.048	32.602	1.114	25.364	1.360	16.322	4.000	4.437	48.000	0.362
1.049	32.427	1.116	25.221	1.370	16.131	4.100	4.324	50.000	0.347
1.050	32.256	1.118	25.081	1.380	15.936	4.200	4.217	55.000	0.316
1.051	32.088	1.120	24.943	1.390	15.747	4.300	4.115	60.000	0.290
1.052	31.923	1.122	24.808	1.400	15.563	4.400	4.018	65.000	0.267
1.053	31.762	1.124	24.675	1.410	15.385	4.500	3.926	70.000	0.248
1.054	31.604	1.126	24.544	1.420	15.211	4.600	3.838	75.000	0.232
1.055	31.449	1.128	24.415	1.430	15.043	4.700	3.753	80.000	0.217
1.056	31.297	1.130	24.289	1.440	14.879	4.800	3.673	85.000	0.204
1.057	31.147	1.132	24.164	1.450	14.719	4.900	3.596	90.000	0.193
1.058	31.000	1.134	24.042	1.460	14.564	5.000	3.522	95.000	0.183
1.059	30.856	1.136	23.921	1.470	14.412	5.200	3.383	100.000	0.174

Amphenol Number	Military Number	Type	Description	Page No.	Amphenol Number	Military Number	Type	Description	Page No.
095-680-58000	-	MMCX	Cable Assembly	15	131-7015-4	-	Precision	Offset Short Circuit Plug	91
095-680-68000	-	MMCX	Cable Assembly	15	131-7016-1	-	Precision	Offset Short Circuit Jack	91
095-680-98000	-	MMCX	Cable Assembly	15	131-7016-2	-	Precision	Offset Short Circuit Jack	91
095-680-98001	-	MMCX	Cable Assembly	15	131-7016-3	-	Precision	Offset Short Circuit Jack	91
095-680-XXXX	-	MMCX	Cable Assembly	15	131-7016-4	-	Precision	Offset Short Circuit Jack	91
102-233-01	-	1.0/2.3	Straight 4-Hole Flange	32	131-7021	-	Precision	APC 3.5 Adapter P/P	90
102-233-10	-	1.0/2.3	Straight 4-Hole Flange	32	131-7022	-	Precision	APC 3.5 Adapter P/J	90
102-233-20	-	1.0/2.3	Straight 4-Hole Flange	32	131-7023	-	Precision	APC 3.5 Adapter J/J	90
102-233-30	-	1.0/2.3	Straight 4-Hole Flange	32	131-7024	-	Precision	APC 3.5 Plug	90
102-243-41	-	1.0/2.3	.141 Cable Plug	28	131-7025	-	Precision	APC 3.5 Jack	90
102-245-01	-	1.0/2.3	Right Angle 4-Hole Flange	32	131-7028	-	Precision	Open Circuit Jack	91
102-245-10	-	1.0/2.3	Right Angle 4-Hole Flange	32	131-7029	-	Precision	Open Circuit Plug	91
102-245-20	-	1.0/2.3	Right Angle 4-Hole Flange	32	131-7033	-	Precision	2.0 CM J/J	91
102-246-41	-	1.0/2.3	.141 Cable Plug	28	131-7034	-	Precision	2.0 CM P/P	91
102-246-85	-	1.0/2.3	.085 Cable Plug	28	131-8001	-	Precision	APC-2.4 Plug	87
102-692-01	-	1.0/2.3	PCB Straight Jack	30	131-8002	-	Precision	APC-2.4 Jack	87
102-692-10	-	1.0/2.3	PCB Bulkhead Jack	30	131-8003	-	Precision	APC-3.5 Jack	88
102-779-20	-	1.0/2.3	LMR200 Cable Plug	27	131-8004	-	Precision	APC-3.5 Plug	88
102-779-48	-	1.0/2.3	LMR240 Cable Plug	27	131-8005	-	Precision	APC-3.5 Plug	88
102-799-04	-	1.0/2.3	RG 58 Cable Plug	27	131-8006	-	Precision	APC-3.5 Jack	88
102-799-04DB	-	1.0/2.3	RG 142B	27	131-8017	-	Precision	K-Female Plug	88
102-799-050	-	1.0/2.3	50Ω Terminator	33	131-8018	-	Precision	K-Male Jack	88
102-799-06	-	1.0/2.3	Cable Plug	27	131-8019	-	Precision	K-Male Plug	88
102-799-104	-	1.0/2.3	RG 58 Angle Plug	29	131-8020	-	Precision	K-Female Jack	88
102-799-104DB	-	1.0/2.3	RG-55, 142 Angle Plug	29	131-8022	-	Precision	SSMA Plug	88
102-799-116	-	1.0/2.3	RG-316 Angle Plug	29	131-91032	-	Precision	APC-7 Coaxial for RG-214/U	94
102-799-116DB	-	1.0/2.3	RD 316 Angle Plug	29	131-91038	-	Adapters	Adapter P/APC-7	217
102-799-118	-	1.0/2.3	Mini-Coax Angle Plug	29	131-91045	-	Precision	APC-7-APC 3.5 Plug	90
102-799-141	-	1.0/2.3	RG-402 Angle Plug	29	131-91046	-	Precision	APC-7-APC 3.5 Jack	90
102-799-16DB	-	1.0/2.3	RG 316 Double Braid	27	131-91050	-	Precision	APC-7 Coaxial for 7mm Airline	94
102-799-185	-	1.0/2.3	RG-405 Angle Plug	29	131-91051	-	Precision	APC-7 Coaxial for 7mm Airline	94
102-799-41	-	1.0/2.3	.141 RG 402 Cable Plug	27	131-91057	-	Precision	Coupling Nut	95
102-799-85	-	1.0/2.3	.085 RG 405	27	14000	UG-83/U	Adapters	Adapter J/P	213
102-811-03	-	1.0/2.3	PCB Press Fit Bulkhead	31	156-112-RG59	-	1.6/5.6	Straight Plug	103
102-811-06	-	1.0/2.3	PCB Press Fit	31	156-335-01	-	1.6/5.6	PCB	103
102-907-06	-	1.0/2.3	Angle Plug	29	156-343-03	-	1.6/5.6	Receptacle	103
102-907-34	-	1.0/2.3	L 910/34 RG 180 Angle Jack	29	156-642-RG59	-	1.6/5.6	Bulkhead Jack	103
102-909-02	-	1.0/2.3	PCB Bulkhead Angle Jack	30	156-929-02	-	1.6/5.6	Straight Plug	103
102-909-D100	-	1.0/2.3	PCB Press Fit Jack	31	156-929-34	-	1.6/5.6	Straight Plug	103
102-913-06	-	1.0/2.3	RG 174, 179, 316 Cable Plug	28	156-931-02	-	1.6/5.6	Bulkhead Jack	103
102-913-06DB	-	1.0/2.3	RG 316 Double Braid Cable Plug	28	156-931-34	-	1.6/5.6	Bulkhead Jack	103
102-913-18	-	1.0/2.3	Mini Coax Cable Plug	28	15875	-	BNC 50Ω	178, 196 Clamp Plug	109
102-920-06	-	1.0/2.3	RG 174, 188, 316 Cable Plug	27	16050	-	Adapters	Adapter J/P	213
103-301	MX-103/U	HN	Trim Tool	202	16075	-	Adapters	Adapter J/P	212
11050	UG-1019	HN	Bulkhead Adapter J/J	202	16300	-	BNC 50Ω	180 Clamp Plug	109
11850	PL-258	UHF	Straight Adapter J/J	190	16750	-	HN	Straight Plug	201
131-10003	-	Precision	Plug for 7mm Airline	97	18225	-	BNC 50Ω	PCB Jack	118
131-10004	-	Precision	Jack for 7mm Airline	97	18750	-	Type N	58, 141, 142 Angle Plug	228
131-1052	-	Precision	Bead-Contact Sub-Assembly	95	191-926	-	Precision	Standard Hex Coupling Nut	95
131-1053	-	Precision	Bead	95	21900	-	BNC 50Ω	Tee Adapter - P/J/J	120
131-1054	-	Precision	Contact Sub-Assembly	95	22-1221-32	-	Tools	Die Set	162
131-122	-	Precision	Body for 7mm Airline	95	227-1221-11	M22520/5-11	Tools	Die Set	162
131-126	-	Precision	Fluted Coupling Nut	95	227-1221-13	M22520/5-13	Tools	Die Set	162
131-129	-	Precision	Collet	95	227-1221-15	M22520/5-15	Tools	Die Set	162
131-131	-	Precision	Retainer Sub-Assembly	95	227-1221-23	M22520/5-23	Tools	Die Set	162
131-7001	-	Precision	3.5mm Airline Plug	92	227-1221-25	-	Tools	Die Set	162
131-7002	-	Precision	3.5mm Airline Jack	92	227-1221-29	M22520/5-29	Tools	Die Set	162
131-7004	-	Precision	RG-405 Plug	92	227-1221-3	M22520/5-03	Tools	Die Set	162
131-7005	-	Precision	RG-405 Jack	92	227-1221-37	-	Tools	Die Set	162
131-7006	-	Precision	RG-402 Plug	92	227-1221-57	M22520/5-57	Tools	Die Set	162
131-7007	-	Precision	RG-402 Plug	92	227-1221-59	M22520/5-59	Tools	Die Set	162
131-7008	-	Precision	RG-405 Panel Jack	92	227-1221-61	-	Tools	Die Set	162
131-7015-1	-	Precision	Offset Short Circuit Plug	91	227-1221-9	M22520/5-09	Tools	Die Set	162
131-7015-2	-	Precision	Offset Short Circuit Plug	91	227-1409	-	Tools	Die Set	162
131-7015-3	-	Precision	Offset Short Circuit Plug	91	227-1414	-	Tools	Die Set	162

Amphenol Number	Military Number	Type	Description	Page No.	Amphenol Number	Military Number	Type	Description	Page No.
227-1417	-	Tools	Die Set	163	31-224	-	Twin BNC	108A Plug	172
227-1418	-	Tools	Die Set	163	31-2242	-	TNC	179, 187 Plug	141
227-1419	-	Tools	Die Set	163	31-2242-RFX	-	TNC	179, 187 Plug	141
227-1420	-	Tools	Die Set	163	31-2264-RFX	-	TNC	58, 141, 142 Jack	144
227-1448	-	Tools	Die Set	162	31-2265	-	TNC	Bulkhead Jack	144
227-60	-	Tools	Pneumatic Crimp Tool/Swivel Base	162	31-2300	-	TNC	Jack	146
227-944	M22520/5-01	Tools	Hand Tool Frame	162	31-2300-RFX	-	TNC	Jack	146
227-962	-	Tools	Die Set	163	31-2301	-	TNC	Front Mount Bulkhead Jack	146
227-967	-	Tools	Die Set	163	31-2301-RFX	-	TNC	Front Mount Bulkhead Jack	146
227-980-1	-	Tools	Die Set	162	31-2315	-	TNC	174, 188 Plug	141
227-980-2	-	Tools	Die Set	162	31-2315-RFX	-	TNC	174, 188, 316 Plug	141
227-980-3	-	Tools	Die Set	162	31-2317	-	TNC	174, 188, 316 Straight Plug	144
227-980-7	-	Tools	Die Set	162	31-2318	-	TNC	174, 188, 316 Bulkhead Jack	144
227-987	-	Tools	Die Set	163	31-236	UG-625B/U	BNC 50Ω	Bulkhead Jack	115
26850-RFX	4178269	Twinaxial	Tee Adapter J/P/J	170	31-2367	M23329/4-01,4-03	TNC	58, 141 Plug	141
2900	UG-255/U	Adapters	Adapter P/J	216	31-2367-RFX	-	BNC/TNC	Straight Plug	138
31-10	-	BNC 50Ω	Bulkhead Jack	115	31-2367-RFX	-	TNC	58, 141 Plug	141
31-10-75	-	BNC 75Ω	Bulkhead Jack	127	31-2368	M23329/4-05	TNC	59, 62 Plug	141
31-10-75-RFXG2	-	BNC 75Ω	Bulkhead Jack	127	31-2368-RFX	-	TNC	59, 62 Plug	141
31-10-RFX	-	BNC 50Ω	Bulkhead Jack	115	31-2373	M23329/4-02,4-05	TNC	142, 223 Plug	141
31-10-RFXG1	-	BNC 50Ω	Bulkhead Jack	115	31-238	UG-912/U	BNC 50Ω	Bulkhead Jack	115
31-10152-RFX	-	BNC 50Ω	Grounding Lug	122	31-2381	-	TNC	Angle Plug	143
31-102	UG-657/U	BNC 50Ω	Bulkhead Jack	115	31-2382	-	TNC	58, 141 Angle Plug	143
31-105	-	BNC 50Ω	Panel Bulkhead Jack	114	31-2383	-	TNC	62 Angle Plug	143
31-15	UG-89/U	BNC 50Ω	59, 62, 71, 140, 210 Clamp Jack	112	31-2389	-	TNC	58, 141A Bulkhead Jack	144
31-17	CW-159/U	BNC 50Ω	Male Shorting Cap & Chain	122	31-2389-RFX	-	TNC	59, 62 Bulkhead Jack	144
31-2	UG-88/U	BNC 50Ω	Clamp Plugs	109	31-239	UG-657A/U	BNC 50Ω	Bulkhead Jack	115
31-2-RFX	-	BNC 50Ω	Clamp Plugs	109	31-242	-	BNC 50Ω	179, 187 Crimp Plug	108
31-202	UG-88C/U	BNC 50Ω	Clamp Plugs	109	31-242-RFX	-	BNC 50Ω	179, 187 Crimp Plug	108
31-203	UG-290A/U	BNC 50Ω	Panel Bulkhead Jack	114	31-245	-	BNC 50Ω	179, 187 Bulkhead Jack	113
31-203-RFX	-	BNC 50Ω	Panel Bulkhead Jack	114	31-245-RFX	-	BNC 50Ω	179, 187 Bulkhead Jack	113
31-204	UG-913/U	BNC 50Ω	Crimp Angle Plugs	111	31-2676-1	-	Triax	Panel Receptacle	179
31-206	UG-909/U	BNC 50Ω	Bulkhead Jack	113	31-2743-3	-	Triax	Plug	179
31-207	UG-910/U	BNC 50Ω	Bulkhead Jack	113	31-28	UG-273/U	Adapters	Adapter J/P	212
31-208	UG-274A/U	BNC 50Ω	Tee Adapter - J/P/J	120	31-28-RFX	UG-273/U	Adapters	Adapter J/P	212
31-208-1051	-	BNC 50Ω	Tee Adapter - J/P/J	120	31-30220-1	-	BNC 50Ω	58 Plug	110
31-208-RFX	-	BNC 50Ω	Tee Adapter - J/P/J	120	31-30220-8	-	BNC 50Ω	23 Plug	110
31-212	UG260B/U	BNC 50Ω	Clamp Plugs	109	31-315	-	BNC 50Ω	174, 188, 316 Crimp Plug	108
31-212-1005	-	BNC 50Ω	59 Clamp Plug	109	31-315-1005	-	BNC 50Ω	Dbl. Br. RG-316 Crimp Plug	108
31-212-RFX	-	BNC 50Ω	Clamp Plugs	109	31-315-RFX	-	BNC 50Ω	174, 188, 316 Crimp Plug	108
31-216	UG-201A/U	Adapters	Adapter J/P	212	31-315-RFX	-	BNC 50Ω	174, 188, 316 Clamp Jack	112
31-216-RFX	UG-201A	Adapters	Adapter J/P	212	31-316	-	BNC 50Ω	Crimp Angle Plugs	111
31-217	UG-349A/U	Adapters	Adapter P/J	216	31-316-RFX	Cubic Body	BNC 50Ω	Crimp-Crimp Cube	111
31-217-RFX	-	Adapters	Adapter P/J	216	31-317	-	BNC 50Ω	174, 188, 316 Crimp Jack	112
31-218	UG-491A/U	BNC 50Ω	Straight P/P	119	31-317-RFX	-	BNC 50Ω	174, 188, 316 Crimp Jack	112
31-218-75RFX	-	BNC 75Ω	Adapter P/P	133	31-318	-	BNC 50Ω	Bulkhead Jack	113
31-218-RFX	-	BNC 50Ω	Straight P/P	119	31-318-1001	-	BNC 50Ω	Dbl. Br. 316 Bulkhead Jack	113
31-219	UG-914/U	BNC 50Ω	Straight J/J	119	31-318-RFX	-	BNC 50Ω	Bulkhead Jack	113
31-219-75	-	BNC 75Ω	Adapter J/J	133	31-320	M23329/3-01,3-03	BNC 50Ω	58, 141 Crimp Plug	108
31-219-RFX	-	BNC 50Ω	Straight J/J	119	31-320-1006	-	BNC 50Ω	Crimp Plug	108
31-2208	UG-274B/U	BNC 50Ω	Tee Adapter - J/P/J	120	31-320-RFX	-	BNC 50Ω	58, 141 Crimp Plug	108
31-220G-RFX	-	BNC 50Ω	Bulkhead Adapter - J/J	121	31-3202	UG88E/U	BNC 50Ω	Clamp Plugs	109
31-220H	UG-492A/U	BNC 50Ω	Bulkhead Adapter - J/J	121	31-321	M23329/3-05	BNC 50Ω	59 Crimp Plug	108
31-220N	-	BNC 50Ω	Bulkhead Adapter - J/J	121	31-321-1000	-	BNC 50Ω	Crimp Plug	108
31-220N-75	-	BNC 75Ω	Bulkhead Adapter J/J	134	31-321-10RFX	-	BNC 50Ω	Crimp Plug	108
31-220N-75RFX	-	BNC 75Ω	Bulkhead Adapter J/J	134	31-321-RFX	-	BNC 50Ω	59 Crimp Plug	108
31-220N-RFX	-	BNC 50Ω	Bulkhead Adapter - J/J	121	31-3220	UG-492D/U	BNC 50Ω	Bulkhead Adapter - J/J	121
31-221	UG-1094/U	BNC 50Ω	Bulkhead Jack	115	31-325	-	BNC 50Ω	Belden 8218 Crimp Plug	108
31-221-75RFX	-	BNC 75Ω	Bulkhead Jack	127	31-326	M23329/3-02,3-05	BNC 50Ω	55, 142, 223, 400 Crimp Plug	108
31-221-RFX	-	BNC 50Ω	Bulkhead Jack	115	31-326-RFX	-	BNC 50Ω	55, 142, 223, 400 Crimp Plug	108
31-222	UG-1098/U	BNC 50Ω	Angle Bulkhead Jack	114	31-3301	M39012/16-0101	BNC 50Ω	Clamp Plugs	109
31-2221	UG-1094A/U	BNC 50Ω	Bulkhead Jack	115	31-3302	M39012/16-0102	BNC 50Ω	Clamp Plugs	109
31-2225	-	Twin BNC	Bulkhead Jack	172	31-334	-	BNC 50Ω	Crimp Angle Plugs	111
31-2226	-	Twin BNC	108A Plug	172	31-335	-	BNC 50Ω	58, 141 Crimp Angle Plug	111
31-223	-	Twin BNC	Bulkhead Jack	172	31-335-RFX	-	BNC 50Ω	58, 141 Crimp Angle Plug	111

Amphenol Number	Military Number	Type	Description	Page No.	Amphenol Number	Military Number	Type	Description	Page No.
31-335-RFX	-	BNC/TNC	Right Angle Plug	137	31-5560-RFX	-	BNC 50Ω	Crimp Plug	108
31-336	-	BNC 50Ω	Crimp Angle Plugs	111	31-5607	-	TNC	PCB Right Angle Jack	145
31-336-RFX	-	BNC 50Ω	Crimp Angle Plugs	111	31-5633	-	BNC 50Ω	PCB Bulkhead Jack	117
31-3376	M39012/21-0002	BNC 50Ω	Bulkhead Jack	115	31-5633-1010	-	BNC 50Ω	PCB Bulkhead Jack	117
31-342	-	BNC 50Ω	58, 141 Bulkhead Jack	113	31-5637	-	BNC 50Ω	PCB Angle Bulkhead Jack	117
31-342-RFX	-	BNC 50Ω	Bulkhead Jack	113	31-5640	-	BNC 50Ω	PCB Bulkhead Jack	117
31-343-1002	-	BNC 50Ω	Plenum 59 Bulkhead Jack	113	31-5640-1010	-	BNC 50Ω	PCB Bulkhead Jack	117
31-343-RFX	-	BNC 50Ω	Bulkhead Jack	113	31-5652	-	BNC 50Ω	Hex Nut	117
31-351	-	BNC 50Ω	58, 141 Crimp Plug	108	31-5652	-	BNC 75Ω	Hex Nut	129
31-359	-	BNC 50Ω	59 Crimp Plug	108	31-5653	-	BNC 50Ω	Lockwasher	117
31-371	-	BNC 50Ω	Crimp Plug	108	31-5653	-	BNC 75Ω	Lockwasher	129
31-4237	M39012/24-0001	BNC 50Ω	Bulkhead Jack	115	31-56559-1RFX	-	BNC 50Ω	Plenum 58 Crimp Plug	108
31-4238	M39012/24-0002	BNC 50Ω	Bulkhead Jack	115	31-5660	-	TNC	PCB Right Angle Jack	145
31-4320	M39012/16-0013	BNC 50Ω	58, 141 Crimp Plug	108	31-5677	-	Reverse Polarity	58 Plug	155
31-4321	M39012/16-0015	BNC 50Ω	59 Crimp Plug	108	31-5677-1000	-	Reverse Polarity	142 Plug	155
31-4327	M39012/17-0013	BNC 50Ω	58, 141 Crimp Jack	112	31-5678	-	Reverse Polarity	58 Jack	155
31-4411	-	BNC 50Ω	Belden 8213 Crimp Plug	108	31-5679	-	Reverse Polarity	B9913 Plug	155
31-4427	M39012/16-0503	BNC 50Ω	142, 400 Crimp Plug	108	31-5680	-	Reverse Polarity	B9913 Angle Plug	155
31-4452	M39012/26-0503	TNC	142, 400 Plug	141	31-5684	-	Reverse Polarity	B9913 Jack	155
31-4541	IBM 1836444	BNC 50Ω	59 Plug	110	31-5685	-	Reverse Polarity	178 Panel Jack	155
31-4541-RFX	-	BNC 50Ω	59 Plug	110	31-5686	-	Reverse Polarity	178 Bulkhead Jack	155
31-4542	IBM 1836447	BNC 50Ω	Belden 9268 Plug	110	31-5687	-	Reverse Polarity	58 Bulkhead Jack	155
31-4561	M55339/14-00306	BNC 50Ω	Angle J/P	119	31-5688	-	Reverse Polarity	PCB Right Angle Jack	155
31-4700	-	BNC 50Ω	58 Plug	110	31-5693	-	BNC 50Ω	Tee, Overmolded J/P/J	120
31-4702	-	BNC 50Ω	59 Plug	110	31-5694	-	Reverse Polarity	Panel Jack	155
31-4758	-	BNC 50Ω	PCB Jack	118	31-5705	-	Reverse Polarity	58, 141 Plug	157
31-4774-3	-	Triax	Plug	179	31-5716-4050	-	BNC 75Ω	PCB Vertical Mount	131
31-4791	-	TNC	Straight Adapter J/J	147	31-5787-T	-	Reverse Polarity	174, 188, 316 Bulkhead Jack	157
31-4803	-	BNC 50Ω	Bulkhead Adapter - J/J	121	31-5800	-	BNC 50Ω	58,141 Crimp Plug	108
31-4803-1101	-	BNC 50Ω	Bulkhead Adapter - J/J	121	31-5800	-	BNC 50Ω	???	109
31-4803-75	-	BNC 75Ω	Bulkhead Adapter J/J	134	31-5849-RFX	-	BNC/TNC	Right Angle Plug	138
31-4803-RFX	-	BNC 50Ω	Bulkhead Adapter - J/J	121	31-5900	-	BNC 50Ω	Crimp Plug	108
31-4803-RFX	-	TNC	Front Mount Isolator	146	31-5900	-	BNC 50Ω	???	109
31-4890-1	-	BNC 50Ω	Bulkhead Jack	115	31-5911-RFX	Cubic Body	BNC 50Ω	58, 141 Crimp-Crimp Cube	111
31-5	UG-89/U	BNC 50Ω	223 Clamp Jack	112	31-5914-RFX	Cubic Body	BNC 50Ω	59 Crimp-Crimp Cube	111
31-5-RFX	-	BNC 50Ω	223 Clamp Jack	112	31-5991-RFX	Cubic Body	BNC 50Ω	316 Crimp-Crimp Cube	111
31-5061	-	TNC	59, 62 Plug	142	31-5998-RFX	-	BNC/TNC	Straight Plug	137
31-5136	-	BNC 50Ω	59 Plug	110	31-5999-RFX	-	BNC/TNC	Straight Plug	137
31-5136-RFX	-	BNC 50Ω	59 Plug	110	31-6	CW-123/U	BNC 50Ω	Male Cap & Chain	122
31-5137	-	BNC 50Ω	58 B/U Plug	110	31-6000-RFX	-	BNC/TNC	Straight Plug	138
31-5137-RFX	-	BNC 50Ω	58 B/U Plug	110	31-6001-RFX	-	BNC/TNC	Straight Plug	138
31-5329	-	BNC 50Ω	PCB Jack	118	31-6002-RFX	-	BNC/TNC	Right Angle Plug	138
31-5329-51RFX	-	BNC 50Ω	PCB Jack	118	31-6003-RFX	-	BNC/TNC	Right Angle Plug	138
31-5329-52RFX	-	BNC 50Ω	PCB Jack	118	31-6004-RFX	-	BNC/TNC	Right Angle Plug	137
31-5329-72RFX	-	BNC 75Ω	PCB Jack	130	31-6005-RFX	-	BNC/TNC	Right Angle Plug	137
31-5431	-	BNC 50Ω	PCB Bulkhead Jack	117	31-6006	-	BNC/TNC	Straight Plug	137
31-5431-1010	-	BNC 50Ω	PCB Bulkhead Jack	117	31-6030	-	Reverse Polarity	58, 141 Plug	157
31-5431-10RFX	-	BNC 50Ω	PCB Bulkhead Jack	117	31-6031	-	Reverse Polarity	58, 141 Plug	157
31-5486	-	BNC 50Ω	PCB Angle Bulkhead Jack	117	31-6032	-	Reverse Polarity	58, 141 Plug	157
31-5486-1010	-	BNC 50Ω	PCB Angle Bulkhead Jack	117	31-6033	-	Reverse Polarity	58, 141 Plug	157
31-5486-10RFX	-	BNC 50Ω	PCB Bulkhead Jack	117	31-70000	-	BNC 75Ω	RG-6 Type Crimp Plug	125
31-5493	-	BNC 50Ω	PCB Angle Bulkhead Jack	117	31-70000	-	BNC 75Ω	Belden 89248, Plenum Plug	125
31-5493-1010	-	BNC 50Ω	PCB Bulkhead Jack	117	31-70000-1000	-	BNC 75Ω	RG-6 Type Crimp Plug	125
31-5538	-	BNC 50Ω	PCB Bulkhead Jack	117	31-70008	-	BNC 75Ω	59, 62 Crimp Plug	125
31-5538-1010	-	BNC 50Ω	PCB Bulkhead Jack	117	31-70008-1000	-	BNC 75Ω	ATT 734A Crimp Plug	125
31-5538-10RFX	-	BNC 50Ω	PCB Bulkhead Jack	117	31-70008-3000	-	BNC 75Ω	Crimp Plug	125
31-5539	-	BNC 50Ω	PCB Bulkhead Jack	117	31-70009	-	BNC 75Ω	59, Belden 8241, 8263 Jack	127
31-5539-1010	-	BNC 50Ω	PCB Bulkhead Jack	117	31-70013	-	BNC 75Ω	179, 187 Crimp Plug	125
31-5540	-	BNC 50Ω	PCB Angle Bulkhead Jack	117	31-70013-1000	-	BNC 75Ω	DbI. Br. 179 Crimp Plug	125
31-5540-1010	-	BNC 50Ω	PCB Angle Bulkhead Jack	117	31-70015-1000	-	BNC 75Ω	ATT 19224-L2 Angle Plug	126
31-5540-10RFX	-	BNC 50Ω	PCB Bulkhead Jack	117	31-70016	-	BNC 75Ω	179, 187 Jack	127
31-5556-1RFX	-	BNC 50Ω	Plenum 58 Crimp Plug	108	31-70016-1000	-	BNC 75Ω	Bulkhead Jack	127
31-5556-RFX	-	BNC 50Ω	59 Crimp Plug	108	31-70018	-	BNC 75Ω	Bulkhead Jack	127
31-5557-RFX	-	BNC 50Ω	58 Crimp Plug	108	31-70019	-	BNC 75Ω	Adapter J/J	133
31-5558-RFX	-	BNC 50Ω	6 Type Crimp Plugs	108	31-70020	-	BNC 75Ω	Bulkhead Adapter J/J	134



Amphenol Number	Military Number	Type	Description	Page No.	Amphenol Number	Military Number	Type	Description	Page No.
31-70022	-	BNC 75Ω	Crimp Plug	125	31-8357-6	-	Triax	Times TBF-58 Plug	183
31-70036	-	BNC 75Ω	Tee Adapter J/P/J	133	31-8359-1	-	Triax	Bulkhead Jack	183
31-70040-100T	-	BNC 75Ω	Receptacle	131	31-850	-	BNC 50Ω	Clamp Angle Plug	111
31-70082	-	BNC 75Ω	ATT 735A Angle Plug	126	31-9	UG-306/U	BNC 50Ω	Angle J/P	119
31-70102-T	-	BNC 75Ω	Bulkhead Jack	132	31-9-75	-	BNC 75Ω	Angle Adapter J/P	133
31-70221	-	BNC 75Ω	PCB Angle Bulkhead Jack	131	31-9-RFX	-	BNC 50Ω	Angle J/P	119
31-70222	-	BNC 75Ω	Dbl. Shield 59 Crimp Plug	125	32225	5052750	Twinaxial	RG-22 Plug	169
31-70227-1001	-	BNC 75Ω	Plug	132	33275	Cubic Body	BNC 50Ω	Clamp Angle Plug	111
31-70228-1001	-	BNC 75Ω	Plug	132	34025	UG-536B/U	Type N	Plug	227
31-70229-1001	-	BNC 75Ω	Plug	132	34025-RFX	-	Type N	Plug	227
31-70234	-	BNC 75Ω	Belden 1694 Plug	125	34275	-	Triax	7/8-20 Male Caps	182
31-70235	-	BNC 75Ω	Belden 8281 Plug	125	34300	-	Triax	11/16-24 Male Caps	182
31-70236	-	BNC 75Ω	Belden 8218 Plug	125	34400	-	Triax	59 Jack	181
31-70237	-	BNC 75Ω	Belden 734A Plug	125	34450	-	Triax	Bulkhead Receptacle	181
31-70238	-	BNC 75Ω	Belden 735A Plug	125	34475	-	Triax	Bulkhead Receptacle	181
31-70239	-	BNC 75Ω	ATT 734A Angle Plug	126	35025-RFX	-	Type N	58, 141 Straight Jack	229
31-70240	-	BNC 75Ω	ATT 735A Angle Plug	126	35275	UG-556B/U	Type N	Bulkhead Jack	231
31-71000-RFX	-	BNC 75Ω	RG-6 Type Crimp Plug	125	35650-51	-	BNC 50Ω	Cap & Chain	122
31-71000-RFX	-	BNC 75Ω	Belden 9290, 1152A Plug	125	35650-75	-	BNC 50Ω	Cap & Chain	122
31-71004	-	BNC 75Ω	Bulkhead Jack	127	36250	UG-1095A/U	Type N	Panel Jack	230
31-71008	-	BNC 75Ω	Crimp Plug	125	36500-RFX	-	Type N	59, 62 Straight Jack	229
31-71008-1000	-	BNC 75Ω	Crimp Plug	125	36650-1003	-	BNC 50Ω	Crimp Plug	108
31-71008-1RFX	-	BNC 75Ω	Crimp Plug	125	36650-3RFX	-	BNC 50Ω	Plenum 58 Crimp Plug	108
31-71008-2000	-	BNC 75Ω	Crimp Plug	125	36800	-	BNC 50Ω	58, 141 Crimp Jack	112
31-71008-RFX	-	BNC 75Ω	Crimp Plug	125	36800-RFX	-	BNC 50Ω	58, 141 Crimp Jack	112
31-71010	-	BNC 75Ω	Angle Plug	126	36825	-	TNC	58, 141 Plug	141
31-71010-RFX	-	BNC 75Ω	Angle Plug	126	36875	-	BNC 50Ω	55, 142, 223, 400 Crimp Plug	108
31-71011	-	BNC 75Ω	Bulkhead Jack	127	4400	UG-146/U	Adapters	Adapter P/J	217
31-71011-RFX	-	BNC 75Ω	Bulkhead Jack	127	4500	UG-185/U	BNC 50Ω	Panel Bulkhead Jack	114
31-71013	-	BNC 75Ω	179, 187 Crimp Plug	125	4525	-	BNC 50Ω	Bulkhead Adapter - J/J	121
31-71013-1000	-	BNC 75Ω	Dbl. Br. 179 Crimp Plug	125	46650-51	-	BNC 50Ω	Male Cap	122
31-71013-RFX	-	BNC 75Ω	179, 187 Crimp Plug	125	46650-51RFX	-	BNC 50Ω	Male Cap	122
31-71014-RFX	-	BNC 75Ω	179, 187 Jack	127	46650-75RFX	-	BNC 50Ω	Male Cap	122
31-71016	-	BNC 75Ω	179, 187 Bulkhead Jack	127	46650-93RFX	-	BNC 50Ω	Male Cap	122
31-71016-RFX	-	BNC 75Ω	179, 187 Bulkhead Jack	127	4700-51	MX-554	BNC 50Ω	Cap & Chain	122
31-71032	-	BNC 75Ω	Crimp Plug	125	47000	-	BNC 50Ω	Panel Adapter J/J	119
31-71033	-	BNC 75Ω	Belden 8218 Crimp Plug	125	49000-RFX	-	Type N	Panel Plug	233
31-71034	-	BNC 75Ω	Belden 89292 Plug	125	49000-SRFX	-	Type N	Panel Plug	233
31-71035	-	BNC 75Ω	Crimp Plug	125	5225	UG-1034/U	Adapters	Adapter P/P	216
31-71042	-	BNC 75Ω	PCB Angle Bulkhead Jack	129	5275	-	BNC 50Ω	Male Shorting Cap	122
31-71043	-	BNC 75Ω	PCB Bulkhead Jack	129	52975	-	Triax	11 Type Jack	181
31-71043-1010	-	BNC 75Ω	PCB Bulkhead Jack	129	531-1503-001	-	Type F	Adapter	251
31-71045	-	BNC 75Ω	PCB Angle Bulkhead Jack	129	531-1504-001	-	Type F	Adapter	251
31-71045-1010	-	BNC 75Ω	PCB Angle Bulkhead Jack	129	531-40001	-	Type F	Jack	247
31-71046	-	BNC 75Ω	PCB Bulkhead Jack	129	531-40008	-	Type F	Adapter	251
31-71046-1010	-	BNC 75Ω	PCB Bulkhead Jack	129	531-40009	-	Adapters	Adapter J/J	215
31-71047	-	BNC 75Ω	PCB Bulkhead Jack	129	531-40009	-	Type G	Adapter	257
31-71047-1010	-	BNC 75Ω	PCB Bulkhead Jack	129	531-40010	-	Adapters	Adapter J/P	215
31-71052	-	BNC 75Ω	PCB Angle Bulkhead Jack	129	531-40010	-	Type G	Adapter J/P	257
31-71052-1010	-	BNC 75Ω	PCB Angle Bulkhead Jack	129	531-40017	-	Type G	Receptacle	255
31-71052-10RFX	-	BNC 75Ω	PCB Angle Bulkhead Jack	129	531-40033	-	Type F	Adapter	251
31-71053	-	BNC 75Ω	PCB Angle Bulkhead Jack	129	531-40035-1006	-	Type F	PCB Mount Jack	247
31-71053-1010	-	BNC 75Ω	PCB Angle Bulkhead Jack	129	531-40039	-	Type F	PCB Edge Mount Jack	247
31-71058	-	BNC 75Ω	PCB Angle Bulkhead Jack	129	531-40046	-	Type F	PCB Mount Jack	247
31-71058-1010	-	BNC 75Ω	PCB Angle Bulkhead Jack	129	531-40047-3	-	Type F	PCB Angle Jack	247
31-71059	-	BNC 75Ω	PCB Angle Bulkhead Jack	129	531-40047-4	-	Type F	PCB Angle Jack	247
31-71059-1010	-	BNC 75Ω	PCB Angle Bulkhead Jack	129	531-40051	-	Type G	PCB Mount Receptacle	255
31-71062	-	BNC 75Ω	PCB Bulkhead Jack	131	531-40065	-	Type G	Receptacle	255
31-71063	-	TNC	PCB Vertical Jack	145	531-40070	-	Type G	PCB Mount Receptacle	255
31-71064	-	BNC 75Ω	RG-6 Type Crimp Plug	125	531-40072	-	Type F	Adapter	251
31-71065	-	BNC 75Ω	Dbl. Shield Plug	125	531-40078	-	Type F	Bulkhead Jack	249
31-71066	-	BNC 75Ω	Quad 59 Headend Cable Plug	125	531-40078-1	-	Type F	Bulkhead Jack	249
31-759	IBM 2245373	BNC 50Ω	Grounding Lug	122	531-40084	-	Type F	Bulkhead Jack	249
31-8356-2	-	Triax	Bulkhead Adapter J/J	183	531-40084-1	-	Type F	Bulkhead Jack	249
31-8357-3	-	Triax	Raychem 9530-D-5117 Plug	183	531-40087	-	Type G	Straight Bulkhead Receptacle	256

# Index Part Numbers

Amphenol Number	Military Number	Type	Description	Page No.	Amphenol Number	Military Number	Type	Description	Page No.
531-40088	-	Type G	Straight Bulkhead Receptacle	256	81-183-RFX	-	UHF	58 Jack	195
531-40089	-	Type G	Receptacle	255	81-185-RFX	-	FME	Straight Crimp Plug	207
531-PF67	-	Type F	Adapter	251	81-186-RFX	-	FME	Straight Crimp Jack	207
53100	-	Triax	59 Plug	181	81-187-RFX	-	FME	Straight Crimp Jack	207
53150	-	Triax	58A Type	181	81-188-RFX	-	FME	Adapter P/P	207
53175	-	Triax	11 Type Plug	181	81-189-RFX	-	Adapters	Adapter P/J	218
53200	-	Triax	7/8-20 Bulkhead Adapter	182	81-190-RFX	-	Adapters	Adapter P/P	218
53225	-	Triax	11/16-24 Bulkhead Adapter	182	81-191-RFX	-	Adapters	Adapter P/P	218
53250	-	Triax	8 Type Plug	181	81-192-RFX	-	Adapters	Adapter P/P	218
53250-1000	-	Triax	Coax RG-12 A/U Plug	181	81-193-RFX	-	Adapters	Adapter P/P	218
5575	UG-625/U	BNC 50Ω	Bulkhead Jack	115	81-196-RFX	-	UHF	58/U,58B/U Plug	195
5675	UG-535/U	BNC 50Ω	Angle Bulkhead Jack	114	81-530	UG-573A	C	Straight Plug	199
6225	-	Twinaxial	Panel Receptacle	169	82-100	UG-57B/U	Type N	Adapter P/P	234
6775	UG-959/U	BNC 50Ω	Clamp Plugs	109	82-100-RFX	UG-57B/U	Type N	Adapter P/P	234
6775-75	-	BNC 75Ω	11 Plug	126	82-101	UG-29B/U	Type N	Adapter J/J	234
68150	-	BNC 50Ω	59, 62, 140, 210 Crimp Jack	112	82-101-RFX	UG-29B/U	Type N	Adapter J/J	234
68175-1003	-	BNC 50Ω	Belden 9259 Crimp Plug	108	82-102	UG-107B/U	Type N	Tee Adapter J/P/J	235
68175-1005	-	BNC 50Ω	59 Crimp Plug	108	82-202	UG-21D/U	Type N	Plug	227
68175-1011	-	BNC 50Ω	Crimp Plug	108	82-202-1006	-	Type N	Plug	227
68175-11RFX	-	BNC 50Ω	Plenum 59, 62 Crimp Plug	108	82-202-RFX	-	Type N	Plug	227
68175-5RFX	-	BNC 50Ω	59 Crimp Plug	108	82-209-1006	-	Type N	Straight Jack	229
69475	-	BNC 50Ω	Clamp Plugs	109	82-213	UG-27C/U	Type N	Angle Adapter P/J	235
716-100	-	7/16	.250 Edge Board Mount	268	82-312	UG-1185/U	Type N	Plug	227
716-101	-	7/16	.141 Edge Board Mount	268	82-3202	UG-21E/U	Type N	Plug	227
716-105	-	7/16	.250 Panel Jack	266	82-324	UG-1215	HN	Panel Jack	201
716-106	-	7/16	.141 Panel Jack	266	82-332	M39012/01B0008	Type N	9, 214 Plug	227
716-16	-	7/16	.115 Straight Jack	270	82-340	M39012/01B0007	Type N	8, 213 Plug	227
716-17G	-	7/16	.104 Straight Jack	270	82-340-1052	-	Type N	Plug	227
716-2	-	7/16	RG393 Panel Jack	266	82-346-RFX	-	Type N	8, 213 Bulkhead Jack	232
716-22	-	7/16	.250 Bulkhead Jack	266	82-368	M39012/04-0002	Type N	Panel Jack	233
716-24	-	7/16	.115 Straight Jack	270	82-369	-	Type N	Bulkhead Jack	232
716-27	-	7/16	.141 Bulkhead Jack	266	82-38	UG-59A	HN	Straight Plug	201
716-3	-	7/16	RG393 Angle Plug Interface	267	82-3880-1	-	Triax	59 Type Plug	180
716-47	-	7/16	.094 Straight Jack	270	82-3881-2	-	Triax	11 Type Plug	180
716-49	-	7/16	M3 Receptacle Jack	269	82-3907-1	-	Triax	Panel Receptacle	180
716-69	-	7/16	.250 Panel Jack	266	82-4425	M39012/01-0501	Type N	214, 225, 393 Plug	227
716-7	-	7/16	M3 Receptacle Jack	270	82-4425-1003	-	Type N	Plug	227
716-75	-	7/16	Straight Jack	270	82-4426	M39012/01-0502	Type N	213 Plug	227
716-77	-	7/16	.250 Panel Jack	266	82-4426-11RFX	-	Type N	Plug	227
78800	-	Adapters	Adapter P/J	217	82-4427	M39012/01-0503	Type N	142, 400 Plug	227
78825	-	Adapters	Adapter J/J	213	82-4427-1006	-	Type N	Plug	227
79025	-	Adapters	Adapter P/J	216	82-4429-RFX	-	Type N	Straight Jack	229
79075	-	TNC	Angle Plug	143	82-4440	M39012/05-0501	Type N	214, 225, 393 Angle Plug	228
79100	-	TNC	Bulkhead Adapter J/J	147	82-4440-1001	-	Type N	9, 214, 225, 393 Angle Plug	228
79125	-	TNC	Right Angle Adapter J/P	147	82-4450	M39012/35-0501	SC	Straight Plug	204
7925-RFX	-	Twinaxial	Bulkhead Adapter J/J	170	82-4451	M39012/35-0503	SC	Straight Plug	204
79600	-	TNC	58 Straight Plug	144	82-4454	M39012/40-0501	SC	Bulkhead Jack	204
79675	-	Adapters	Adapter J/P	212	82-4460	M39012/38-0501	SC	Panel Jack	204
79700	-	TNC	Tee Adapter J/P/J	147	82-4474	M39012/39-0501	SC	Angle Plug	204
79825	-	Adapters	Adapter J/P	213	82-4475	M39012/39-0503	SC	Angle Plug	204
79875	-	TNC	Plug	141	82-504	UG-568	C	Panel Receptacle	199
79875-RFX	-	TNC	58, 142A Plug	141	82-515	UG-634	C	Panel Receptacle	199
81-114-RFX	-	UHF	Plug	195	82-532	UG-628A	C	Straight Plug	199
81-115BK-1000	-	UHF	58 Plug	195	82-535	UG-567A	C	Angle Adapter J/P	199
81-115N-1000	-	UHF	58 Plug	195	82-5370	-	Type N	55, 142, 223	227
81-116	-	UHF	58 Jack	195	82-5372	-	Type N	Panel Jack	230
81-118-1001	-	UHF	Panel Receptacle	195	82-5373	-	Type N	55, 142, 223 Bulkhead Jack	231
81-119-1007	-	UHF	PCB Angle Bulkhead Jack	195	82-5374	-	Type N	55, 142, 223 Angle Plug	228
81-120	-	UHF	Bulkhead Receptacle	195	82-5375	-	Type N	58, 141 Plug	227
81-160	-	FME	Straight Crimp Jack	207	82-5375-RFX	-	Type N	58, 141 Plug	227
81-161	-	Adapters	Adapter P/P	218	82-5376-RFX	-	Type N	59, 62 Straight Jack	229
81-162	-	Adapters	Adapter P/P	218	82-5378	-	Type N	58, 141 Bulkhead Jack	231
81-169	-	FME	Straight Crimp Plug	207	82-5378-RFX	-	Type N	58, 141 Bulkhead Jack	232
81-181-RFX	-	UHF	59 Plug	195	82-5380-RFX	-	Type N	59, 62 Plug	227
81-182-RFX	-	UHF	59 Jack	195	82-5550	M55339/01-0001	Adapters	Adapter J/J	215

# Index Part Numbers

Amphenol Number	Military Number	Type	Description	Page No.	Amphenol Number	Military Number	Type	Description	Page No.
82-5558	M55339/20-00	Adapters	Adapter J/P	212	83-185	UG-175/U	UHF	Reducing Adapter	187
82-5561	-	Adapters	Adapter J/J	219	83-185-RFX	-	UHF	Reducing Adapter	187
82-5588	-	Twinaxial	Barrel Adapter J/J	170	83-1AC	-	UHF	Cap & Chain	191
82-5588-RFX	-	Twinaxial	Barrel Adapter J/J	170	83-1AC-RFX	-	UHF	Cap & Chain	191
82-5589-RFX	7362229	Twinaxial	Plug	169	83-1AP	UG-646/U	UHF	Angle Adapter J/P	190
82-5590-2RFX	-	Twinaxial	Front Mount Receptacle	169	83-1F	UG-363/U	UHF	Bulkhead Adapter J/J	190
82-5590-RFX	-	Twinaxial	Front Mount Receptacle	169	83-1H	UG-106/U	UHF	Hood	190
82-5677-RFX	-	Twinaxial	Tee Adapter J/J/J/	170	83-1J	PL-258	UHF	Straight Adapter J/J	190
82-5721-1000	-	Type N	Cap	236	83-1R	SO-239	UHF	Panel Receptacle	189
82-5721-10RFX	-	Type N	Terminator Jack	236	83-1R-RFX	-	UHF	Panel Receptacle	189
82-5722-RFX	-	Type N	Cap	236	83-1SP	PL-259	UHF	Plug	187
82-5933	-	Type N	188, 316 Bulkhead Jack	231	83-1SP-1050	PL-259	UHF	Plug	187
82-5955-RFX	-	Type N	Plug	227	83-1SP-15RFX	-	UHF	Plug	187
82-5956-RFX	-	Type N	Plug	227	83-1T	M-358	UHF	Tee Adapter J/P/J	190
82-5988-1000	-	Type N	214, 393 Angle Plug	228	83-58DCP-2	-	UHF	Plug	187
82-5988-1004	-	Type N	214, 393 Angle Plug	228	83-58DCP-2RFX	-	UHF	Plug	187
82-5993	-	Type N	Plug	227	83-58FCP	-	UHF	Plug	187
82-5994	-	Type N	LMR 600 Bulkhead Jack	231	83-58FCP-RFX	-	UHF	Plug	187
82-5995	-	Type N	Angle Plug	228	83-58SCP-RFX	-	UHF	58 Plug	188
82-6010	-	Type N	Plug	227	83-58SP	-	UHF	58, 142 Plug	188
82-6034	-	Type N	174, 188, 316 Plug	227	83-58SP-1002	-	UHF	400 Plug	188
82-6048-1000	-	Type N	Angle Plug	228	83-59	-	UHF	Angle Plug	188
82-6092-RFX	-	Type N	58, 141 Straight Jack	229	83-59DCP-RFX	-	UHF	59 Plug	188
82-6093-RFX	-	Type N	174, 188, 316 Bulkhead Jack	232	83-59SP	-	UHF	59 Plug	188
82-6095-RFX	-	Type N	Panel Jack	233	83-67	-	UHF	Angle Plug	188
82-6096-RFX	-	Type N	405 Bulkhead Jack	232	83-750	UG-111/U	UHF	Plug	187
82-6097-RFX	-	Type N	402 Bulkhead Jack	232	83-765	UG-177/U	UHF	Hood	190
82-6098-RFX	-	Type N	Panel Jack	230	83-798	SO-239A	UHF	Panel Receptacle	189
82-6099-RFX	-	Type N	Panel Jack	230	83-822	PL-259	UHF	Plug	187
82-6100-RFX	-	Type N	Panel Plug	233	83-875	-	UHF	Bulkhead Receptacle	189
82-6101-RFX	-	Type N	Panel Jack	233	83-875-1002	-	UHF	Bulkhead Receptacle	189
82-6106	-	Type N	Plug	227	83-876	-	UHF	Panel Receptacle	189
82-6124	-	Type N	Plug	227	83-877	PL-258	UHF	Straight Adapter P/P	190
82-6142-1000	-	Type N	Plug	227	83-878	-	UHF	Bulkhead Receptacle	189
82-6143-1000	-	Type N	LMR 400 Bulkhead Jack	231	83-878-1003	-	UHF	Bulkhead Receptacle	189
82-6151	-	Type N	LMR 240, 8X Bulkhead Jack	231	83-878-RFX	-	UHF	Bulkhead Receptacle	189
82-6152	-	Type N	Plug	227	83-8SP-RFX	-	UHF	8 Plug	188
82-6156	-	Type N	174, 188, 316 Bulkhead Jack	231	83-910-RFX	-	Adapters	Adapter P/P	218
82-6157	-	Type N	Angle Plug	228	84975	UG1033/U	BNC 50Ω	122 Clamp Plug	109
82-6158	-	Type N	Straight Jack	229	8525	Cubic Body	BNC 50Ω	Clamp Angle Plug	111
82-6162	-	Type N	401 Bulkhead Jack	232	8575	-	BNC 50Ω	Clamp Angle Plug	111
82-6163-RFX	-	Type N	Panel Jack	230	86350	-	BNC 50Ω	Bulkhead Jack	113
82-6165	-	Type N	Angle Plug	228	86425	-	BNC 50Ω	Panel Jack	112
82-6166	-	Type N	Angle Plug	228	86850	-	BNC 50Ω	178, 196 Bulkhead Jack	113
82-62	UG-23B/U	Type N	Panel Jack	230	901-10003	-	SMA	PCB Receptacle	64
82-63	UG-23B/U	Type N	Straight Jack	229	901-10005	-	Adapters	Adapter P/J	211
82-63-RFX	-	Type N	8,213,214 Straight Jack	229	901-10006	-	Adapters	Adapter J/P	211
82-64	UG-27A/U	Type N	Angle Adapter P/J	235	901-10007	-	Adapters	Adapter P/P	211
82-64-RFX	-	Type N	Angle Adapter J/P	235	901-10008	-	Adapters	Adapter J/J	211
82-66	UG-30/U	Type N	Bulkhead Adapter J/J	235	901-10009-RFX	-	SMA	LMR 240 Plug	77
82-66-RFX	UG-30/U	Type N	Bulkhead Adapter J/J	235	901-10010-RFX	-	SMA	LMR 200 Plug	77
82-804	UG-59B	HN	Straight Plug	201	901-10011	-	SMA	LMR 240 Plug	60
82-805	UG-560	HN	Panel Receptacle	202	901-10012	-	SMA	LMR 200 Plug	60
82-816-1000	-	HN	Straight Plug	201	901-10013-RFX	-	SMA	Bulkhead Jack	78
82-843	-	HN	Bulkhead Receptacle	202	901-10014	-	SMA	LMR 240 Right Angle Plug	61
82-856	-	HN	Angle Plug	201	901-10015	-	SMA	LMR 240 Bulkhead Jack	63
82-91	UG-212A	HN	Angle Adapter J/P	202	901-10019	-	SMA	PCB Receptacle	64
82-92	UG-496	HN	Panel Receptacle	202	901-10021-12SF	-	SMA	Dbl. Braid 316 Bulkhead Jack	63
82-97	UG-58A/U	Type N	Panel Jack	233	901-10021-1SF	-	SMA	Bulkhead Jack	63
82-97-RFX	-	Type N	Panel Jack	233	901-10021-3SF	-	SMA	Bulkhead Jack	63
82-99	UG-28A/U	Type N	Tee Adapter J/J/J	235	901-10024-RFX	-	SMA	RD 174, 188, 316 Plug	77
82-GB635-CR	-	Twinaxial	Plug	169	901-10025-RFX	-	SMA	174, 188, 316 Plug	77
83-10	-	Adapters	Adapter J/P	214	901-10028-RFX	-	SMA	Angle Plug	78
83-168	UG-176/U	UHF	Reducing Adapter	187	901-10029-RFX	-	SMA	Angle Plug	78
83-168-RFX	-	UHF	Reducing Adapter	187	901-10032	-	SMA	Bulkhead Receptacle	71

# Index Part Numbers

Amphenol Number	Military Number	Type	Description	Page No.	Amphenol Number	Military Number	Type	Description	Page No.
901-10032-SF	-	SMA	Bulkhead Receptacle	71	901-9216	-	SMA	In-Series Adapters	74
901-101-15	M39012/55-4502	SMA	142B, 400 Plug	60	901-9216-SF	-	SMA	In-Series Adapters	74
901-103	-	SMA	55, 58, 141, 142,223 Plug	59	901-9217	-	SMA	In-Series Adapters	74
901-125-11	-	SMA	In-Series Adapters	74	901-9217-SF	-	SMA	In-Series Adapters	74
901-125-11SF	M553399/02-30001	SMA	In-Series Adapters	74	901-9218-SF	-	SMA	In-Series Adapters	74
901-128-11	M39012/55-4007	SMA	174, 316 Plug	59	901-9220	-	SMA	Bulkhead Receptacle	71
901-143	-	SMA	PCB Receptacle	64	901-9220-SF	-	SMA	Bulkhead Receptacle	71
901-143-3	-	SMA	PCB Receptacle	64	901-9221-1A	-	SMA	.141 RG-402 Right Angle Plug	61
901-143-4	-	SMA	PCB Receptacle	64	901-9221-2A	-	SMA	.085 RG-405 Right Angle Plug	61
901-143-6RFX	-	SMA	Brass PCB Angle	82	901-9221-2ASF	-	SMA	.085 RG-405 Right Angle Plug	61
901-144	-	SMA	PCB Receptacle	64	901-9244-1	-	SMA	Panel Jack	70
901-144-2	-	SMA	PCB Receptacle	64	901-9244-1SF	-	SMA	Panel Jack	70
901-144-3	-	SMA	PCB Receptacle	64	901-9244-2	-	SMA	Panel Jack	69
901-144-4	-	SMA	PCB Receptacle	64	901-9501-3	-	SMA	Plug	59
901-144-8RFX	-	SMA	Brass PCB Jack	82	901-9511-1	-	SMA	55B, 142B, 223, 400 Plug	60
901-144-PFD	-	SMA	PCB Jack	65	901-9511-12SF	-	SMA	Dbl. Braid RG-188, 316 Plug	60
901-164	-	Adapters	Adapter P/P	216	901-9511-12SFC	-	SMA	Dbl. Braid RG-188, 316 Plug	60
901-165	-	Adapters	Adapter P/J	216	901-9511-1SF	-	SMA	55B, 142B, 223, 400 Plug	60
901-166	-	Adapters	Adapter J/P	212	901-9511-1SFC	-	SMA	55B, 142B, 223, 400 Plug	60
901-167	-	Adapters	Adapter J/J	212	901-9511-2	-	SMA	58 Plug	60
901-168	-	Adapters	Adapter P/P	217	901-9511-2SF	-	SMA	58 Plug	60
901-171	-	Adapters	Adapter J/J	214	901-9511-3	-	SMA	174, 187, 188, 316 Plug	60
901-178	-	SMA	In-Series Adapters	75	901-9511-3SFC	-	SMA	Plug	60
901-280	-	Adapters	Adapter J/J	219	901-9521-3	-	SMA	right Angle Plug	61
901-292	-	Adapters	Adapter P/P	217	901-9531-1	-	SMA	Right Angle Plug	61
901-293	-	Adapters	Adapter J/P	213	901-9531-12	-	SMA	Right Angle Plug	61
901-294	-	Adapters	Adapter P/J	217	901-9531-12SF	-	SMA	Right Angle Plug	61
901-295	-	Adapters	Adapter J/J	213	901-9531-1SF	-	SMA	Right Angle Plug	61
901-3143-1000	-	Adapters	Adapter J/J	219	901-9531-2	-	SMA	58, 141 Right Angle Plug	61
901-382-1	-	SMA	In-Series Adapters	75	901-9531-2SF	-	SMA	58, 141 Right Angle Plug	61
901-44-PF8	-	SMA	PCB Jack	65	901-9531-3	-	SMA	Right Angle Plug	61
901-508	-	SMA	Phase Adjustable Adapter	84	901-9531-3SF	-	SMA	Right Angle Plug	61
901-509	-	SMA	Phase Adjustable Plug	84	901-9601-1SF	-	SMA	55B, 142B, 223, 400 Plug	59
901-8741	-	SMA	Bulkhead Receptacle	71	901-9601-3	-	SMA	Plug	59
901-9000-CC	-	SMA	Panel Jack	69	901-9601-3SF	-	SMA	Plug	59
901-9023	-	SMA	Bulkhead Receptacle	72	901-9602-1	-	SMA	55, 142, 223, 400 Jack	62
901-9033	-	Adapters	Adapter J/J	214	901-9602-12SF	-	SMA	Dbl. Braid RG-316 Jack	62
901-9034	-	Adapters	Adapter J/P	214	901-9602-1SF	-	SMA	55, 142, 223, 400 Jack	62
901-9038	-	Adapters	Adapter P/P	217	901-9602-3	-	SMA	55, 142, 223, 400 Jack	62
901-9102-A	-	SMA	.141 RG-402	58	901-9602-3SF	-	SMA	Jack	62
901-911-3SF	-	SMA	174, 187, 188, 316 Plug	60	901-9610-12SF	-	SMA	Dbl. Braid 316 Bulkhead Jack	63
901-9173	-	Adapters	Adapter J/J	219	901-9610-1SF	-	SMA	Bulkhead Jack	63
901-9184-CCSF	-	SMA	Panel Jack	67	901-9610-3	-	SMA	Bulkhead Jack	63
901-9185-CCSF	-	SMA	Panel Jack	69	901-9610-3SF	-	SMA	Bulkhead Jack	63
901-9201-1ASF	-	SMA	.141 RG-402	58	901-9704	-	SMA	.141 RG-402 Jack	62
901-9201-2A	-	SMA	.085 RG-405	58	901-9718	-	Adapters	Adapter J/J	219
901-9201-2ASF	-	SMA	.085 RG-405	58	901-9720	-	Adapters	Adapter J/J	219
901-9202-1A	-	SMA	.141 RG-402 Jack	62	901-9723	-	SMA	.085 RG-405	58
901-9202-2A	-	SMA	.085 RG-405 Jacks	62	901-9723-10	-	SMA	.085 RG-405	58
901-9204-3CCSF	-	SMA	PCB Jack	66	901-9757	-	SMA	Panel Jack	67
901-9204-4CC	-	SMA	PCB Jack	66	901-9758	-	SMA	PCB Jack	66
901-9204-4CCSF	-	SMA	PCB Jack	66	901-9760	-	SMA	Panel Plug	68
901-9204-CC	-	SMA	Panel Jack	67	901-9767	-	SMA	Panel Plug	68
901-9204-CCSF	-	SMA	Panel Jack	67	901-9770	-	SMA	Panel Jack	70
901-9209-A	-	SMA	In-Series Adapters	75	901-9788	-	SMA	Panel Plug	68
901-9209-ASF	-	SMA	In-Series Adapters	75	901-9789	-	SMA	Panel Jack	67
901-9210-1	-	SMA	.141 RG-402 Bulkhead Jack	63	901-9801-1	-	SMA	.141 RG-402	58
901-9210-2	-	SMA	.085 RG-405 Bulkhead Jacks	63	901-9801-2	-	SMA	.141 RG-402	58
901-9211	-	SMA	Bulkhead Receptacle	71	901-9804-1	-	SMA	Panel Jack	67
901-9211-SF	-	SMA	Bulkhead Receptacle	71	901-9808	-	SMA	.141 RG-402	58
901-9214-CC	-	SMA	Panel Plug	68	901-9814	-	SMA	Panel Jack	70
901-9214-CCSF	-	SMA	Panel Plug	68	901-9835	-	SMA	Bulkhead Receptacle	71
901-9215	-	SMA	PCB Jack	66	901-9839	-	SMA	Panel Jack	67
901-9215-3CCSF	-	SMA	Panel Jack	67	901-9842	-	SMA	Bulkhead Receptacle	73
901-9215-SF	-	SMA	PCB Jack	66					

Amphenol Number	Military Number	Type	Description	Page No.	Amphenol Number	Military Number	Type	Description	Page No.
901-9847	-	SMA	Bulkhead Receptacle	72	903-369P-51A2	-	SMB	Dbl. Braid 316 Angle Plug	37
901-9850	-	SMA	PCB Receptacle	64	903-370P-51S	-	SMB	Plug	37
901-9852	-	Reverse Polarity	174 Plug	151	903-371P-51S	-	SMB	RG-178, 196 Plug	37
901-9856	-	SMA	Bulkhead Receptacle	72	903-373J-51A	-	SMB	PCB Angle Jack	42
901-9857	-	Reverse Polarity	.141 Bulkhead Jack	152	903-375J-53P	-	SMB	PCB Bulkhead Jack	41
901-9863	-	Reverse Polarity	174 Bulkhead Jack	152	903-376J-51A	-	SMB	PCB Angle Bulkhead Jack	42
901-9864	-	Reverse Polarity	PCB Edge Mount Jack	152	903-377A-52B1	-	Adapters	Adapter J/J	219
901-9865	-	Reverse Polarity	PCB Right Angle Jack	152	903-378J-52A	-	SMC	PCB Jack	54
901-9866	-	Reverse Polarity	.141 Plug	151	903-382J-71R	-	SMB	Bulkhead Jack, Rear Mount	46
901-9867-RFX	-	SMA	.085 Plug	77	903-401P-51S	-	SMB	Dbl. Braid 316 Plug	37
901-9868-RFX	-	SMA	.141 Plug	77	903-402J-51R	-	SMB	Bulkhead Jack, Front Mount	39
901-9870	-	SMA	58 Plug	77	903-406J-51R	-	SMB	Bulkhead Jack, Front Mount	39
901-9871	-	SMA	141, 223 Plug	77	903-407J-51R	-	SMB	bulkhead jack	40
901-9872	-	SMA	Angle Plug	78	903-408J-52R	-	SMC	Bulkhead Jack	53
901-9873	-	SMA	58 Brass Angle Plug	78	903-409J-53P	-	SMB	PCB Interconnect	41
901-9874	-	SMA	141, 223 Brass Angle Plug	78	903-410P-53P	-	SMB	PCB Interconnect	41
901-9875	-	SMA	Bulkhead Jack	78	903-413J-51A	-	SMB	PCB Angle Bulkhead Jack	42
901-9876-RFX	-	SMA	58 Plug	77	903-415J-51P	-	SMB	PCB Jack	43
901-9877-RFX	-	SMA	174, 188, 316 Plug	77	903-416J-51R	-	SMB	Angle Bulkhead Jack	40
901-9879-RFX	-	SMA	Bulkhead Jack	78	903-419J-52	-	SMC	PCB Bulkhead Jack	54
901-9880-RFX	-	SMA	58 Brass Angle Plug	78	903-420J-52P	-	SMC	PCB Jack Receptacle	54
901-9881-RFX	-	SMA	Angle Plug	78	903-421J-52P	-	SMC	PCB Bulkhead Jack	54
901-9884	-	Reverse Polarity	55, 142, 223, 400 Plug	151	903-422J-51A	-	SMB	Bulkhead Jack	38
901-9887-RFX	-	SMA	Brass Panel Jack	79	903-422J-51A2	-	SMB	Dbl. Shield 316 Bulkhead Jack	38
901-9888	-	SMA	Brass Panel Jack	80	903-429P-51A	-	SMB	Plug	37
901-9889-RFX	-	SMA	Brass Bulkhead Jack	80	903-495P-71A	-	SMB	621-4460-75 Angle Plug	45
901-9890-RFX	-	SMA	Brass Bulkhead Jack	80	903-499J-51P	-	SMB	PCB Bulkhead Jack	43
901-9891-RFX	-	SMA	Brass Panel Jack	79	903-499J-51P1	-	SMB	PCB Bulkhead Jack	43
901-9892-RFX	-	SMA	Brass Panel Jack	79	903-499J-51P2	-	SMB	PCB Jack	43
901-9893-RFX	-	SMA	Brass Panel Jack	79	903-499J-51P3	-	SMB	PCB Jack	43
901-9894-RFX	-	SMA	Brass PCB Angle	81	903-502P-71S	-	SMB	Plug	45
901-9895-RFX	-	SMA	Brass PCB Plug	81	903-505J-51S	-	SMB	Bulkhead Jack	38
901-9902	-	SMA	Angle Plug	78	903-505J-51S1	-	SMB	Dbl. Shield 316 Bulkhead Jack	38
901-9908	-	Reverse Polarity	223 Plug	151	903-508P-51S	-	SMB	Plug	37
901-9909	-	SMA	Bulkhead Receptacle	73	903-509P-51S	-	SMB	RG-178, 196 Plug	37
901-9911	-	SMA	Bulkhead Receptacle	73	903-512J-71P	-	SMB	PCB Jack	49
901-9916	-	SMA	RD 174, 188, 316 Plug	77	903-515J-51P	-	SMB	PCB Bulkhead Jack	43
901-9990	-	Reverse Polarity	178 Bulkhead Jack	152	903-516P-71S	-	SMB	735A Type Plug	48
903-10408-1	-	SMC	Jam Nut	53	903-517P-71A	-	SMB	735A Type Plug	48
903-10408-1,-2	-	SMB	Jam Nut	39	903-518J-51P	-	SMB	PCB Bulkhead Jack	43
903-10408-2	-	SMC	Jam Nut	53	903-518J-71P	-	SMB	PCB Jack	49
903-10409-1	-	SMC	Lockwasher	53	903-519J-71P	-	SMB	PCB Jack	49
903-10409-1,-2	-	SMB	Lockwasher	39	903-522P-71P	-	SMB	PCB Plug	46
903-10409-2	-	SMC	Lockwasher	53	903-523J-71P	-	SMB	PCB Jack	46
903-108J-71S	-	SMB	RG-179 Bulkhead Jack	45	903-524P-71P	-	SMB	PCB Plug	49
903-152P-71S	-	SMB	RG-180, 195 Plug	45	903-535P-71A	-	SMB	179 Angle Plug	48
903-152P-71S3	-	SMB	RG-179 Plug	45	903-536P-71S	-	SMB	179 Plug	48
903-152P-71S7	-	SMB	735A Plug	45	903-574P-71S	-	SMB	RG-179 Plug	45
903-284P-52S	-	SMC	Plug	53	903-575P-71S	-	SMB	RD-179 Plug	45
903-284P-52S1	-	SMC	Plug	53	903-577P-51S	-	SMB	Plug	37
903-285P-51S	-	SMB	Plug	37	903-577P-51S1	-	SMB	Plug	37
903-287P-51S	-	SMB	RG-178, 196 Plug	37	903-578P-51S	-	SMB	RG-178, 196 Plug	37
903-288P-52A	-	SMC	Plug	53	903-578P-51S1	-	SMB	RG-178, 196 Plug	37
903-289P-51A	-	SMB	Plug	37	903-579P-51S	-	SMB	Dbl. Braid 316 Plug	37
903-289P-51A2	-	SMB	Plug	37	903-579P-51S1	-	SMB	Dbl. Braid 316 Plug	37
903-291P-51A	-	SMB	RG-178, 196 Angle Plug	37	903-585J-71A	-	SMB	PCB Jack	46
903-291P-51A1	-	SMB	RG-178, 196 Angle Plug	37	904-9805-HP	-	SMA	.085 RG-405	58
903-305J-51R	-	SMB	Bulkhead Jack, Rear Mount	39	908-21100	-	MMCX	Edgecard Plug	9
903-362P-52A1	-	SMC	Dbl. Br. 316 Angle Plug	53	908-21100T	-	MMCX	Edgecard Plug, Tape & Reel	9
903-367P-51A	-	SMB	Plug	37	908-21102	-	MMCX	Edgecard Plug, Offset	9
903-367P-51A1	-	SMB	Plug	37	908-21103	-	MMCX	Straight PCB Plug	11
903-367P-51A2	-	SMB	Plug	37	908-21106	-	MMCX	Straight Jack PCB	11
903-368P-51A	-	SMB	RG-178, 196 Angle Plug	37	908-22100	-	MMCX	Edgecard Jack	9
903-368P-51A1	-	SMB	RG-178, 196 Angle Plug	37	908-22100T	-	MMCX	Edgecard Jack, Tape & Reel	9
903-369P-51A	-	SMB	Dbl. Braid 316 Angle Plug	37	908-22101	-	MMCX	MicroMate™ Surface Mounts	7

Amphenol Number	Military Number	Type	Description	Page No.	Amphenol Number	Military Number	Type	Description	Page No.
908-22101-TC	-	MMCX	MicroMate™ Surface Mounts	7	A6NF	-	Type N-Corg.	Straight Jack	242
908-22101B	-	MMCX	MicroMate™ Surface Mounts	7	A6NF-H	-	Type N-Corg.	Straight Jack	242
908-22101T	-	MMCX	MicroMate™ Surface Mounts	7	A6PDF	-	7/16	Straight Jack Interface	264
908-22102T	-	MMCX	Edgecard Plug	9	A6PDF-H	-	7/16	Straight Jack Interface	264
908-22103	-	MMCX	Edgecard Jack, Offset	9	A6PNF-H	-	Type N-Corg.	Straight Jack	242
908-24100	-	MMCX	R/A Jack, PCB	11	A6WDF	-	7/16	Straight Jack Interface	264
908-31100	-	Adapters	Adapter P/J	218	A6WNF	-	Type N-Corg.	Straight Jack	242
908-32101	-	Adapters	Adapter J/P	215	A7NF-1	-	Type N-Corg.	Straight Jack	242
908-41200	-	MMCX	RG-178, 196 Cable Connector	12	A7PDF	-	7/16	Straight Jack Interface	264
908-41300	-	MMCX	Cable Connector	12	A7PDM	-	Miniature RF	Straight Plug Interface	263
908-41400	-	MMCX	.086 Cable Connector	12	A7WDF	-	7/16	Straight Jack Interface	264
908-41500	-	MMCX	RD-316 Cable Connector	12	A7WDM	-	Miniature RF	Straight Plug Interface	263
908-41600	-	MMCX	.047 Cable Connector	13	A7WNF	-	Type N-Corg.	Straight Jack	242
908-42300	-	MMCX	Cable Connector	13	APH-716F-F	-	7/16	Adapter	271
908-42500	-	MMCX	RD-316 Cable Connector	13	APH-716F-NF	-	Adapters	Adapter J/J	220
908-43200	-	MMCX	Cable Connector	13	APH-716F-NM	-	Adapters	Adapter J/P	220
908-43300	-	MMCX	Cable Connector	14	APH-716M-M	-	7/16	Adapter	271
908-43400	-	MMCX	.086 Cable Connector	14	APH-716M-NF	-	Adapters	Adapter P/J	220
908-43500	-	MMCX	RD-316 Cable Connector	14	APH-716M-NM	-	Adapters	Adapter P/P	220
908-43600	-	MMCX	.047 Cable Connector	14	CTL-1	-	Tools	Crimp Tool	160
919-101P-51S1X	-	MCX	Cable Connector	19	CTL-13	-	Tools	Crimp Tool	164
919-101P-51SX	-	MCX	Cable Connector	19	CTL-14	-	Tools	Crimp Tool	164
919-102P-51AX	-	MCX	.085 Cable Connector	20	CTL-2	-	Tools	Crimp Tool	160
919-103P-51AX	-	MCX	.141 Cable Connector	20	CTL-3	-	Tools	Crimp Tool	160
919-104P-51A1X	-	MCX	Cable Connector	19	CTL-4	-	Tools	Crimp Tool	160
919-104P-51AX	-	MCX	Cable Connector	19	CTL-5	-	Tools	Crimp Tool	160
919-107J-51SX	-	MCX	Cable Connector	19	CTL-6	-	Tools	Crimp Tool	160
919-109J-51PX	-	MCX	PCB Panel Jack	21	CTL-8	-	Tools	Crimp Tool	160
919-114J-51SX	-	MCX	.085 Cable Connector	20	PCTL-100	-	Tools	For BNC & TNC 3-Pc Connector	160
919-118J-51P	-	MCX	PCB Panel Jack D17	21	PCTL-1100	-	Tools	Die Set	161
919-119J-51AX	-	MCX	PCB Panel Jack	21	PCTL-1300	-	Tools	Die Set	164
919-120P-51SX	-	MCX	.085 Cable Connector	20	PCTL-1400	-	Tools	Die Set	164
919-121P-51SX	-	MCX	Cable Connector	19	PCTL-200	-	Tools	Die Set	161
919-122P-51AX	-	MCX	RG-178, 196 Cable Connector	19	PCTL-400	-	Tools	Die Set	161
919-128J-51SX	-	MCX	Cable Connector	19	PCTL-500	-	Tools	Die Set	161
919-129J-51SX	-	MCX	RD-316 Cable Connector	19	PCTL-600	-	Tools	Die Set	161
919-130P-51SX	-	MCX	RD-316 Cable Connector	19	PCTL-800	-	Tools	Die Set	161
919-131J-51SX	-	MCX	Cable Connector	19	S12WNF	-	Type N-Corg.	Straight Jack	242
919-132J-71P	-	MCX	RG-316 Cable Connector	23	S1PNM-S	-	Type N-Corg.	Straight Plug	240
919-136P-71A2X	-	MCX	RD-179 Cable Connector	23	S1PNR	-	Type N-Corg.	Angle Plug	241
919-136P-71AX	-	MCX	RG-179 Cable Connector	23	S1WNM	-	Type N-Corg.	Straight Plug	240
919-137P-71S2X	-	MCX	RD-179 Cable Connector	23	S2PDF-PM	-	7/16	Panel Mount Jack Interface	264
919-137P-71SX	-	MCX	RG-179 Cable Connector	23	S2PDM	-	Miniature RF	Straight Plug Interface	263
9350	-	BNC 50Ω	6 Crimp Plug	109	S2PDR	-	Miniature RF	Angle Plug Interface	263
95700	-	BNC 50Ω	55, 142, 223 Bulkhead Jack	113	S2PNF-BH	-	Type N-Corg.	Bulkhead Jack	243
A4NF	-	Type N-Corg.	Straight Jack	242	S2PNM-S	-	Type N-Corg.	Straight Plug	240
A4NF-S	-	Type N-Corg.	Straight Jack	242	S2PNR-SO	-	Type N-Corg.	Angle Plug	241
A4NM	-	Type N-Corg.	Straight Plug	240	S2WNM	-	Type N-Corg.	Straight Plug	240
A4NM-S	-	Type N-Corg.	Straight Plug	240	S2WNM-SO	-	Type N-Corg.	Straight Plug	240
A4PDF	-	7/16	Straight Jack Interface	264	S4NF-S	-	Type N-Corg.	Straight Jack	242
A4PDM	-	Miniature RF	Straight Plug Interface	263	S4NM-S	-	Type N-Corg.	Straight Plug	240
A4PDR	-	Miniature RF	Angle Plug Interface	263	S4PDF	-	7/16	Straight Jack Interface	264
A4PNF-S	-	Type N-Corg.	Straight Jack	242	S4PDF-PM	-	7/16	Panel Mount Jack Interface	264
A4PNM	-	Type N-Corg.	Straight Plug	240	S4PDF-PM-SO	-	7/16	Panel Mount Jack Interface	264
A4PNM-S	-	Type N-Corg.	Straight Plug	240	S4PDM	-	Miniature RF	Straight Plug Interface	263
A4PNR	-	Type N-Corg.	Angle Plug	241	S4PDR	-	Miniature RF	Angle Plug Interface	263
A4WDM	-	Miniature RF	Straight Plug Interface	263	S4PNF-S	-	Type N-Corg.	Straight Jack	242
A4WNF	-	Type N-Corg.	Straight Jack	242	S4PNR	-	Type N-Corg.	Angle Plug	241
A5NF	-	Type N-Corg.	Straight Jack	242	S4PNR-S	-	Type N-Corg.	Angle Plug	241
A5NM	-	Type N-Corg.	Straight Plug	240	S4WDM-U	-	Miniature RF	Straight Plug Interface	263
A5PDF	-	7/16	Straight Jack Interface	264	S4WNF-U	-	Type N-Corg.	Straight Jack	242
A5PDM	-	Miniature RF	Straight Plug Interface	263	S4WNM-SU	-	Type N-Corg.	Straight Plug	240
A5PNM	-	Type N-Corg.	Straight Plug	240	S4WNM-U	-	Type N-Corg.	Straight Plug	240
A5WDF	-	7/16	Straight Jack Interface	264					
A5WNF	-	Type N-Corg.	Straight Jack	242					

Amphenol Number	Series	Assembly Instruction	Description	Page No.	Amphenol Number	Series	Assembly Instruction	Description	Page No.
102-799-41	1.0/2.3	C78	Straight connector for SR Cable	343	18750	Type N	C8	Clamp Types	280
102-799-85	1.0/2.3	C78	Straight connector for SR Cable	343	31-15	BNC	C25	Clamp Connectors	299
102-243-41	1.0/2.3	C78	Straight connector for SR Cable	343	31-2	BNC	C25	Clamp Connectors	299
102-246-41	1.0/2.3	C78	Straight connector for SR Cable	343	31-2-RFX	BNC	C25	Clamp Connectors	299
102-246-85	1.0/2.3	C78	Straight connector for SR Cable	343	31-202	BNC	C25	Clamp Connectors	299
102-799-04	1.0/2.3	C79	Straight Connector for Flex.	344	31-204	BNC	C25	Clamp Connectors	299
102-799-04DB	1.0/2.3	C79	Straight Connector for Flex.	344	31-206	BNC	C25	Clamp Connectors	299
102-799-16	1.0/2.3	C79	Straight Connector for Flex.	344	31-207	BNC	C25	Clamp Connectors	299
102-799-16DB	1.0/2.3	C79	Straight Connector for Flex.	344	31-212	BNC	C25	Clamp Connectors	299
102-799-20	1.0/2.3	C79	Straight Connector for Flex.	344	31-212-1005	BNC	C25	Clamp Connectors	299
102-799-48	1.0/2.3	C79	Straight Connector for Flex.	344	31-2226	Twin BNC	C33	Clamp Plugs	308
102-920-06	1.0/2.3	C79	Straight Connector for Flex.	344	31-224	Twin BNC	C33	Clamp Plugs	308
102-799-104	1.0/2.3	C80	Right Angle Connector for Flex.	345	31-2242	TNC	C36	Crimp-Crimp Type	310
102-799-104DB	1.0/2.3	C80	Right Angle Connector for Flex.	345	31-2242-RFX	TNC	C36	Crimp-Crimp Type	310
102-799-116DB	1.0/2.3	C80	Right Angle Connector for Flex.	345	31-2264	TNC	C36	Crimp-Crimp Type	310
102-799-118	1.0/2.3	C80	Right Angle Connector for Flex.	345	31-2264-RFX	TNC	C36	Crimp-Crimp Type	310
102-799-120	1.0/2.3	C80	Right Angle Connector for Flex.	345	31-2315	TNC	C36	Crimp-Crimp Type	310
102-799-116	1.0/2.3	C80	Right Angle Connector for Flex.	345	31-2315-RFX	TNC	C36	Crimp-Crimp Type	310
102-907-06	1.0/2.3	C80	Right Angle Connector for Flex.	345	31-2317	TNC	C36	Crimp-Crimp Type	310
102-907-34	1.0/2.3	C80	Right Angle Connector for Flex.	345	31-2318	TNC	C36	Crimp-Crimp Type	310
102-913-06	1.0/2.3	C81	Straight Jacks for Flexible Cable	346	31-2318	TNC	C36	Crimp-Crimp Type	310
102-913-18	1.0/2.3	C81	Straight Jacks for Flexible Cable	346	31-2367	TNC	C36	Crimp-Crimp Type	310
102-913-06DB	1.0/2.3	C81	Straight Jacks for Flexible Cable	346	31-2367-RFX	TNC	C36	Crimp-Crimp Type	310
102-799-85	1.0/2.3	C82	Right Angle Jacks for SR Cable	347	31-2367-RFX	TNC	C36	Crimp-Crimp Type	310
102-799-141	1.0/2.3	C82	Right Angle Jacks for SR Cable	347	31-2368	TNC	C36	Crimp-Crimp Type	310
131-7001	Precision	C66	3.5mm Airline Plug	92	31-2368-RFX	TNC	C36	Crimp-Crimp Type	310
131-7002	Precision	C66	3.5mm Airline Jack	92	31-2373	TNC	C36	Crimp-Crimp Type	310
131-7004	Precision	C66	RG-405 Plug	92	31-2381	TNC	C36	Crimp-Crimp Type	310
131-7005	Precision	C66	RG-405 Jack	92	31-2381	TNC	C36	Crimp-Crimp Type	310
131-7006	Precision	C66	RG-402 Plug	92	31-2382	TNC	C36	Crimp-Crimp Type	310
131-7007	Precision	C66	RG-402 Jack	92	31-2383	TNC	C36	Crimp-Crimp Type	310
131-7008	Precision	C66	RG-405 Panel Jack	92	31-2389	TNC	C36	Crimp-Crimp Type	310
131-7015-1	Precision	C66	2-4 GHz Plug	91	31-2389-RFX	TNC	C36	Crimp-Crimp Type	310
131-7015-2	Precision	C66	4-8 GHz Plug	91	31-242	BNC	C26	3-Piece Crimp Plugs	300
131-7015-3	Precision	C66	8-12.4 GHz Plug	91	31-242-RFX	BNC	C26	3-Piece Crimp Plugs	300
131-7015-4	Precision	C66	12.4-18 GHz Plug	91	31-245	BNC	C26a	3-Piece Crimp Angle P & Bulkhead J	301
131-7016-1	Precision	C66	2-4 GHz Jack	91	31-245-RFX	BNC	C26a	3-Piece Crimp Angle P & Bulkhead J	301
131-7016-2	Precision	C66	4-8 GHz Jack	91	31-2743-3	Triax BNC	C13	Plug 2-Braid Clamp	286
131-7016-3	Precision	C66	8-12.4 GHz Jack	91	31-30220-1	BNC	C29	QuickTrim Plug	304
131-7016-4	Precision	C66	12.4-18 GHz Jack	91	31-30220-8	BNC	C29	QuickTrim Plug	304
131-7024	Precision	C66	APC 3.5 Plug	90	31-315	BNC	C26	3-Piece Crimp Plugs	300
131-7025	Precision	C66	APC 3.5 Jack	90	31-315-RFX	BNC	C26	3-Piece Crimp Plugs	300
131-7028	Precision	C66	APC 3.5 Jack	91	31-315-RFX	BNC	C26a	3-Piece Crimp Angle P & Bulkhead J	301
131-7029	Precision	C66	APC 3.5 Plug	91	31-316	BNC	C26a	3-Piece Crimp Angle P & Bulkhead J	301
131-8001	Precision	C65	APC 2.4 Plug	87	31-316-RFX	BNC	C26a	3-Piece Crimp Angle P & Bulkhead J	301
131-8002	Precision	C65	APC 2.4 Jack	87	31-317	BNC	C26a	3-Piece Crimp Angle P & Bulkhead J	301
131-10003	Precision	C67	7mm Airline	97	31-317-RFX	BNC	C26a	3-Piece Crimp Angle P & Bulkhead J	301
131-10004	Precision	C67	7mm Airline	97	31-318	BNC	C26a	3-Piece Crimp Angle P & Bulkhead J	301
131-91032	Precision	C67	RG-214	94	31-318-1001	BNC	C26a	3-Piece Crimp Angle P & Bulkhead J	301
131-91050	Precision	C67	7mm Airline	94	31-318-RFX	BNC	C26a	3-Piece Crimp Angle P & Bulkhead J	301
131-91051	Precision	C67	7mm Airline	94	31-320	BNC	C26	3-Piece Crimp Plugs	300
15875	BNC	C25	Clamp Connectors	299	31-320-1006	BNC	C26	3-Piece Crimp Plugs	300
16300	BNC	C25	Clamp Connectors	299	31-320-RFX	BNC	C26	3-Piece Crimp Plugs	300
16750	HN	C18	Typical Clamp	292	31-3202	BNC	C25	Clamp Connectors	299

Amphenol Number	Series	Assembly Instruction	Description	Page No.	Amphenol Number	Series	Assembly Instruction	Description	Page No.
31-321	BNC	C26	3-Piece Crimp Plugs	300	31-5800	BNC	C26	3-Piece Crimp Plugs	300
31-321-1000	BNC	C26	3-Piece Crimp Plugs	300	31-5849-RFX	TNC	C36	Crimp-Crimp Type	310
31-321-10RFX	BNC	C26	3-Piece Crimp Plugs	300	31-5900	BNC	C26	3-Piece Crimp Plugs	300
31-321-RFX	BNC	C26	3-Piece Crimp Plugs	300	31-5911-RFX	BNC	C26a	3-Piece Crimp Angle P & Bulkhead J	301
31-325	BNC	C26	3-Piece Crimp Plugs	300	31-5914-RFX	BNC	C26a	3-Piece Crimp Angle P & Bulkhead J	301
31-326	BNC	C26	3-Piece Crimp Plugs	300	31-5991-RFX	BNC	C26a	3-Piece Crimp Angle P & Bulkhead J	301
31-326-RFX	BNC	C26	3-Piece Crimp Plugs	300	31-5998-RFX	BNC	C26a	3-Piece Crimp Angle P & Bulkhead J	301
31-3301	BNC	C25	Clamp Connectors	299	31-5999-RFX	BNC	C26a	3-Piece Crimp Angle P & Bulkhead J	301
31-3302	BNC	C25	Clamp Connectors	299	31-6000-RFX	TNC	C36	Crimp-Crimp Type	310
31-334	BNC	C26a	3-Piece Crimp Angle P & Bulkhead J	301	31-6001-RFX	TNC	C36	Crimp-Crimp Type	310
31-335	BNC	C26a	3-Piece Crimp Angle P & Bulkhead J	301	31-6002-RFX	TNC	C36	Crimp-Crimp Type	310
31-335-RFX	BNC	C26a	3-Piece Crimp Angle P & Bulkhead J	301	31-6003-RFX	TNC	C36	Crimp-Crimp Type	310
31-335-RFX	BNC	C26a	3-Piece Crimp Angle P & Bulkhead J	301	31-6004-RFX	BNC	C26a	3-Piece Crimp Angle P & Bulkhead J	301
31-336	BNC	C26a	3-Piece Crimp Angle P & Bulkhead J	301	31-6005-RFX	BNC	C26a	3-Piece Crimp Angle P & Bulkhead J	301
31-336-RFX	BNC	C26a	3-Piece Crimp Angle P & Bulkhead J	301	31-6006	BNC	C26a	3-Piece Crimp Angle P & Bulkhead J	301
31-342	BNC	C26a	3-Piece Crimp Angle P & Bulkhead J	301	31-6030	RP-BNC, RP-TNC	C38	Crimp Types	312
31-342-RFX	BNC	C26a	3-Piece Crimp Angle P & Bulkhead J	301	31-6031	RP-BNC, RP-TNC	C38	Crimp Types	312
31-343-1002	BNC	C26a	3-Piece Crimp Angle P & Bulkhead J	301	31-6032	RP-BNC, RP-TNC	C38	Crimp Types	312
31-343-RFX	BNC	C26a	3-Piece Crimp Angle P & Bulkhead J	301	31-6033	RP-BNC, RP-TNC	C38	Crimp Types	312
31-351	BNC	C26b	Original Crimp Plugs	302	31-6034	RP-BNC, RP-TNC	C38	Crimp Types	312
31-359	BNC	C26b	Original Crimp Plugs	302	31-6035	RP-BNC, RP-TNC	C38	Crimp Types	312
31-371	BNC	C26b	Original Crimp Plugs	302	31-6036	RP-BNC, RP-TNC	C38	Crimp Types	312
31-4320	BNC	C26	3-Piece Crimp Plugs	300	31-70000	BNC	C31	Crimp Term. for Type 1-75Ω Con.	306
31-4321	BNC	C26	3-Piece Crimp Plugs	300	31-70000-1000	BNC	C31	Crimp Term. for Type 1-75Ω Con.	306
31-4327	BNC	C26a	3-Piece Crimp Angle P & Bulkhead J	301	31-70008	BNC	C31	Crimp Term. for Type 1-75Ω Con.	306
31-4411	BNC	C26	3-Piece Crimp Plugs	300	31-70008-1000	BNC	C31	Crimp Term. for Type 1-75Ω Con.	306
31-4427	BNC	C26	3-Piece Crimp Plugs	300	31-70008-3000	BNC	C31	Crimp Term. for Type 1-75Ω Con.	306
31-4452	TNC	C36	Crimp-Crimp Type	310	31-70009	BNC	C31	Crimp Term. for Type 1-75Ω Con.	306
31-4541	BNC	C29	QuickTrim Plug	304	31-70013	BNC	C31	Crimp Term. for Type 1-75Ω Con.	306
31-4541-RFX	BNC	C29	QuickTrim Plug	304	31-70013-1000	BNC	C31	Crimp Term. for Type 1-75Ω Con.	306
31-4542	BNC	C29	QuickTrim Plug	304	31-70015-1000	BNC	C31	Crimp Term. for Type 1-75Ω Con.	306
31-4700	BNC	C30	Plugs FCP Termination	305	31-70016	BNC	C31	Crimp Term. for Type 1-75Ω Con.	306
31-4702	BNC	C30	Plugs FCP Termination	305	31-70016-1000	BNC	C31	Crimp Term. for Type 1-75Ω Con.	306
31-4774-3	Triax BNC	C12	Plug 2-Braid Clamp	284	31-70022	BNC	C31	Crimp Term. for Type 1-75Ω Con.	306
31-5061	TNC	C37	QuickTrim Plug	311	31-70082	BNC	C31	Crimp Term. for Type 1-75Ω Con.	306
31-5136	BNC	C28	SureTwist Plug	303	31-70222	BNC	C31	Crimp Term. for Type 1-75Ω Con.	306
31-5136-RFX	BNC	C28	SureTwist Plug	303	31-70235	BNC	C26a	3-Piece Crimp Angle P & Bulkhead J	301
31-5137	BNC	C28	SureTwist Plug	303	31-70236	BNC	C26a	3-Piece Crimp Angle P & Bulkhead J	301
31-5137-RFX	BNC	C28	SureTwist Plug	303	31-70237	BNC	C26a	3-Piece Crimp Angle P & Bulkhead J	301
31-5556-RFX	UHF	C7R	2-Piece Crimp Plugs	279	31-70238	BNC	C26a	3-Piece Crimp Angle P & Bulkhead J	301
31-5557-RFX	UHF	C7R	2-Piece Crimp Plugs	279	31-70239	BNC	C26a	3-Piece Crimp Angle P & Bulkhead J	301
31-5558-RFX	BNC	C26	3-Piece Crimp Plugs	300	31-70240	BNC	C26a	3-Piece Crimp Angle P & Bulkhead J	301
31-5560-RFX	UHF	C7R	2-Piece Crimp Plugs	279	31-71000-RFX	BNC	C32	Crimp Term. for Type 2-75Ω Con.	307
31-5677	RP-BNC, RP-TNC	C38	Crimp Types	312	31-71008	BNC	C32	Crimp Term. for Type 2-75Ω Con.	307
31-5677-1000	RP-BNC, RP-TNC	C38	Crimp Types	312	31-71008-1000	BNC	C32	Crimp Term. for Type 2-75Ω Con.	307
31-5678	RP-BNC, RP-TNC	C38	Crimp Types	312	31-71008-1RFX	BNC	C32	Crimp Term. for Type 2-75Ω Con.	307
31-5679	RP-BNC, RP-TNC	C38	Crimp Types	312	31-71008-RFX	BNC	C32	Crimp Term. for Type 2-75Ω Con.	307
31-5680	RP-BNC, RP-TNC	C38	Crimp Types	312	31-71010	BNC	C32	Crimp Term. for Type 2-75Ω Con.	307
31-5684	RP-BNC, RP-TNC	C38	Crimp Types	312	31-71010-RFX	BNC	C32	Crimp Term. for Type 2-75Ω Con.	307
31-5685	RP-BNC, RP-TNC	C38	Crimp Types	312	31-71011	BNC	C32	Crimp Term. for Type 2-75Ω Con.	307
31-5686	RP-BNC, RP-TNC	C38	Crimp Types	312	31-71011-RFX	BNC	C32	Crimp Term. for Type 2-75Ω Con.	307
31-5687	RP-BNC, RP-TNC	C38	Crimp Types	312	31-71013	BNC	C32	Crimp Term. for Type 2-75Ω Con.	307
31-5705	RP-BNC, RP-TNC	C38	Crimp Types	312	31-71013-1000	BNC	C32	Crimp Term. for Type 2-75Ω Con.	307
31-5787	RP-BNC, RP-TNC	C38	Crimp Types	312	31-71013-RFX	BNC	C32	Crimp Term. for Type 2-75Ω Con.	307



Amphenol Number	Series	Assembly Instruction	Description	Page No.	Amphenol Number	Series	Assembly Instruction	Description	Page No.
31-71014-RFX	BNC	C32	Crimp Term. for Type 2-75Ω Con.	307	81-185-RFX	FME	C22	Connector Term. Instructions	296
31-71016	BNC	C32	Crimp Term. for Type 2-75Ω Con.	307	81-186-RFX	FME	C22	Connector Term. Instructions	296
31-71016-RFX	BNC	C32	Crimp Term. for Type 2-75Ω Con.	307	81-187-RFX	FME	C22	Connector Term. Instructions	296
31-71032	BNC	C32	Crimp Term. for Type 2-75Ω Con.	307	81-196-RFX	Mini-UHF	C39	Crimp-Crimp Type	313
31-71033	BNC	C32	Crimp Term. for Type 2-75Ω Con.	307	82-202	Type N	C8	Clamp Types	280
31-71034	BNC	C32	Crimp Term. for Type 2-75Ω Con.	307	82-202-1006	Type N	C8	Clamp Types	280
31-71035	BNC	C32	Crimp Term. for Type 2-75Ω Con.	307	82-202-RFX	Type N	C8	Clamp Types	280
31-71064	BNC	C32	Crimp Term. for Type 2-75Ω Con.	307	82-209-1006	Type N	C8	Clamp Types	280
31-71065	BNC	C32	Crimp Term. for Type 2-75Ω Con.	307	82-312	Type N	C8	Clamp Types	280
31-71066	BNC	C32	Crimp Term. for Type 2-75Ω Con.	307	82-3202	Type N	C8	Clamp Types	280
31-71234	BNC	C26a	3-Piece Crimp Angle P & Bulkhead J	301	82-324	HN	C17	Typical Clamp	291
31-8357-3	Triax TNC	C13	Plug, Male Contacts	286	82-332	Type N	C11	Crimp-Crimp Type	283
31-8357-6	Triax TNC	C13	Plug, Male Contacts	286	82-340	Type N	C11	Crimp-Crimp Type	283
31-850	BNC	C25	Clamp Connectors	299	82-340-1052	Type N	C11	Crimp-Crimp Type	283
32225	Twinaxial	C19	Clamp Plugs	293	82-340-1054	Type N	C11	Crimp-Crimp Type	283
33275	BNC	C25	Clamp Connectors	299	82-38	HN	C20	Typical Clamp	294
34025	Type N	C8	Clamp Types	280	82-3880-1	Triax C	C23	Bayonet Lock	297
34025-RFX	Type N	C8	Clamp Types	280	82-3881-2	Triax C	C23	Bayonet Lock	297
34400	Triax Threaded	C15	11/16-24 Straight Jack	289	82-4425	Type N	C11	Crimp-Crimp Type	283
35275	Type N	C8	Clamp Types	280	82-4425-1003	Type N	C11	Crimp-Crimp Type	283
36250	Type N	C8	Clamp Types	280	82-4426	Type N	C11	Crimp-Crimp Type	283
36650-1003	BNC	C26	3-Piece Crimp Plugs	300	82-4426-1001	Type N	C11	Crimp-Crimp Type	283
36650-3RFX	BNC	C26	3-Piece Crimp Plugs	300	82-4426-1002	Type N	C11	Crimp-Crimp Type	283
36800	BNC	C26a	3-Piece Crimp Angle P & Bulkhead J	301	82-4426-11RFX	Type N	C11	Crimp-Crimp Type	283
36800-RFX	BNC	C26a	3-Piece Crimp Angle P & Bulkhead J	301	82-4427	Type N	C11	Crimp-Crimp Type	283
36825	TNC	C36	Crimp-Crimp Type	310	82-4427-1006	Type N	C11	Crimp-Crimp Type	283
36875	BNC	C26	3-Piece Crimp Plugs	300	82-4440	Type N	C11	Crimp-Crimp Type	283
52975	Triax Threaded	C15	7/8-20 Straight Jack	289	82-4440-1001	Type N	C11	Crimp-Crimp Type	283
53100	Triax Threaded	C15	11/16-24 Straight Plug	289	82-4450	SC	C21	Crimp-Crimp Type	295
53150	Triax Threaded	C15	11/16-24 Straight Plug	289	82-4451	SC	C21	Crimp-Crimp Type	295
53175	Triax Threaded	C15	7/8-20 Straight Plug	289	82-4454	SC	C21	Mil-Crimp Type	295
53250	Triax Threaded	C15	7/8-20 Straight Plug	289	82-4460	SC	C21	Crimp-Crimp Type	295
53250-1000	Triax Threaded	C15	7/8-20 Straight Plug	289	82-4474	SC	C21	Crimp-Crimp Type	295
6775	BNC	C25	Clamp Connectors	299	82-4475	SC	C21	Crimp-Crimp Type	295
6775-75	BNC	C25	Clamp Connectors	299	82-530	C	C16	Two-Stud Bayonet Lock	290
68150	BNC	C26a	3-Piece Crimp Angle P & Bulkhead J	301	82-532	C	C16	Two-Stud Bayonet Lock	290
68175-1003	BNC	C26	3-Piece Crimp Plugs	300	82-5370	Type N	C11	Crimp-Crimp Type	283
68175-1005	BNC	C26	3-Piece Crimp Plugs	300	82-5372	Type N	C11	Crimp-Crimp Type	283
68175-1011	BNC	C26	3-Piece Crimp Plugs	300	82-5373	Type N	C11	Crimp-Crimp Type	283
68175-11RFX	BNC	C26	3-Piece Crimp Plugs	300	82-5374	Type N	C11	Crimp-Crimp Type	283
68175-5RFX	BNC	C26	3-Piece Crimp Plugs	300	82-5375	Type N	C11	Crimp-Crimp Type	283
69475	BNC	C25	Clamp Connectors	299	82-5375-RFX	Type N	C11	Crimp-Crimp Type	283
79075	TNC	C34	Clamp Types	309	82-5378	Type N	C11	Crimp-Crimp Type	283
79600	TNC	C34	Clamp Types	309	82-5589	Twinaxial	C19	Clamp Plugs	293
79875	TNC	C34	Clamp Types	309	82-5589-RFX	Twinaxial	C19	Clamp Plugs	293
81-114-RFX	Mini-UHF	C39	Crimp-Crimp Type	313	82-5933	Type N	C11	Crimp-Crimp Type	283
81-115BK-1000	Mini-UHF	C39	Crimp-Crimp Type	313	82-5955-RFX	Type N	C9	Right Angle J for SR Cable	281
81-115N-1000	Mini-UHF	C39	Crimp-Crimp Type	313	82-5956-RFX	Type N	C9	Right Angle J for SR Cable	281
81-116	Mini-UHF	C39	Crimp-Crimp Type	313	82-5988-1000	Type N	C11	Crimp-Crimp Type	283
81-160	FME	C22	Connector Term. Instructions	296	82-5988-1000	Type N	C11	Crimp-Crimp Type	283
81-169	FME	C22	Connector Term. Instructions	296	82-5988-1004	Type N	C11	Crimp-Crimp Type	283
81-181-RFX	Mini-UHF	C39	Crimp-Crimp Type	313	82-5988-1004	Type N	C11	Crimp-Crimp Type	283
81-182-RFX	Mini-UHF	C39	Crimp-Crimp Type	313	82-5993	Type N	C11	Crimp-Crimp Type	283
81-183-RFX	Mini-UHF	C39	Crimp-Crimp Type	313	82-5994	Type N	C11	Crimp-Crimp Type	283

Amphenol Number	Series	Assembly Instruction	Description	Page No.	Amphenol Number	Series	Assembly Instruction	Description	Page No.
82-5995	Type N	C11	Crimp-Crimp Type	283	901-10021-3SF	SMA	C53	Crimp/Solder CC Type for Flex. Cable	321
82-6010	Type N	C11	Crimp-Crimp Type	283	901-10024-RFX	SMA	C53	Crimp/Solder CC Type for Flex. Cable	321
82-6096-RFX	Type N	C9	Right Angle J for SR CableCable	281	901-10025-RFX	SMA	C53	Crimp/Solder CC Type for Flex. Cable	321
82-6097-RFX	Type N	C9	Right Angle J for SR CableCable	281	901-10028-RFX	SMA	C53	Crimp/Solder CC Type for Flex. Cable	321
82-6098-RFX	Type N	C9	Right Angle J for SR CableCable	281	901-10029-RFX	SMA	C53	Crimp/Solder CC Type for Flex. Cable	321
82-6099-RFX	Type N	C9	Right Angle J for SR CableCable	281	901-101-15	SMA	C55	Crimp-Crimp Types for Flexible Cable	323
82-6106	Type N	C11	Crimp-Crimp Type	283	901-103	SMA	C43	Clamp Type for Flexible Cable	314
82-6124	Type N	C9	Right Angle J for SR CableCable	281	901-128-11	SMA	C44	Modified Clamp Type for Flex. Cables	315
82-6162	Type N	C9	Right Angle J for SR CableCable	281	901-370P-51S	SMB	C60	Crimp Type P & Bulkhead J	328
82-6163-RFX	Type N	C9	Right Angle J for SR CableCable	281	901-509	SMA	C51	Phase Adjustable	320
82-63	Type N	C8	Clamp Types	280	901-9201-1A	SMA	C49,C50	Solder to Body SMA Angle Plugs	319
82-67	Type N	C8	Clamp Types	280	901-9201-1ASF	SMA	C49,C50	Solder to Body SMA Angle Plugs	319
82-804	HN	C17	Typical Clamp	291	901-9201-2A	SMA	C47	Solder Body/Pressfit Ins. for SR	317
82-804	HN	C17	Typical Clamp	291	901-9201-2ASF	SMA	C47	Solder Body/Pressfit Ins. for SR	317
82-816-1000	HN	C18	Typical Clamp	292	901-9202-1A	SMA	C47	Solder Body/Pressfit Ins. for SR	317
82-GB635-CR	Twinaxial	C10	Insulated Twinax Plug	282	901-9202-2A	SMA	C47	Solder Body/Pressfit Ins. for SR	317
83-1H	UHF	C7	Hoods for Adapting PR to CC	278	901-9210-1	SMA	C47	Solder Body/Pressfit Ins. for SR	317
83-1SP	UHF	C2	UG Standard Solder Type	275	901-9210-2	SMA	C47	Solder Body/Pressfit Ins. for SR	317
83-1SP	UHF	C1	UG Standard Solder Type	274	901-9501-3	SMA	C46	Solder Type for Flexible Cables	316
83-1SP-1050	UHF	C1	UG Standard Solder Type	274	901-9511-1	SMA	C53	Crimp-Crimp Types for Flexible Cable	321
83-1SP-1050	UHF	C2	UG Standard Solder Type	275	901-9511-12SF	SMA	C55	Crimp-Crimp Types for Flexible Cable	323
83-1SP-15RFX	UHF	C1	UG Standard Solder Type	274	901-9511-12SFC	SMA	C55	Crimp-Crimp Types for Flexible Cable	323
83-1SP-15RFX	UHF	C2	UG Standard Solder Type	275	901-9511-1SF	SMA	C53	Crimp/Solder CC Type for Flex. Cable	321
83-58DCP-2	UHF	C5	Crimp-Crimp Type	276	901-9511-1SFC	SMA	C55	Crimp-Crimp Types for Flexible Cable	323
83-58DCP-2RFX	UHF	C5	Crimp-Crimp Type	276	901-9511-1SF	SMA	C53	Crimp/Solder CC Type for Flex. Cable	321
83-58FCP	UHF	C6	FCP Term. for Plugs on RG-58	277	901-9511-2	SMA	C53	Crimp/Solder CC Type for Flex. Cable	321
83-58FCP-RFX	UHF	C6	FCP Term. for Plugs on RG-58	277	901-9511-2SF	SMA	C53	Crimp/Solder CC Type for Flex. Cable	321
83-58SCP-RFX	UHF	C4	Braid Crimp-Solder Center Contact	276	901-9511-3	SMA	C55	Crimp-Crimp Types for Flexible Cable	323
83-58SP	UHF	C4	Braid Crimp-Solder Center Contact	276	901-9511-3SF	SMA	C55	Crimp-Crimp Types for Flexible Cable	323
83-58SP-1002	UHF	C4	Braid Crimp-Solder Center Contact	276	901-9511-3SFC	SMA	C55	Crimp-Crimp Types for Flexible Cable	323
83-59	UHF	C1	UG Standard Solder Type	274	901-9521-3	SMA	C46	Solder Type for Flexible Cables	316
83-59DCP-RFX	UHF	C4	Braid Crimp-Solder Center Contact	276	901-9531-1	SMA	C53	Crimp/Solder CC Type for Flex. Cable	321
83-59SP	UHF	C4	Braid Crimp-Solder Center Contact	276	901-9531-12,-12SF	SMA	C53	Crimp/Solder CC Type for Flex. Cable	321
83-67	UHF	C1	UG Standard Solder Type	274	901-9531-12,-12SF	SMA	C57	Braid Crimp-Solder CC Types for Flex.	325
83-750	UHF	C2	UG Standard Solder Type	275	901-9531-1SF	SMA	C53	Crimp/Solder CC Type for Flex. Cable	321
83-765	UHF	C7	Hoods for Adapting PR to CC	278	901-9531-2	SMA	C53	Crimp/Solder CC Type for Flex. Cable	321
83-822	UHF	C1	UG Standard Solder Type	274	901-9531-2SF	SMA	C53	Crimp/Solder CC Type for Flex. Cable	321
83-822	UHF	C2	UG Standard Solder Type	275	901-9531-3,-3SF	SMA	C53	Crimp/Solder CC Type for Flex. Cable	321
83-8SP-RFX	UHF	C4	Braid Crimp-Solder Center Contact	276	901-9531-3,-3SF	SMA	C57	Braid Crimp-Solder CC Types for Flex.	325
84975	BNC	C25	Clamp Connectors	299	901-9601-1SF	SMA	C56	Braid Crimp-Solder CC Types for Flex.	324
8525	BNC	C25	Clamp Connectors	299	901-9601-3	SMA	C56	Braid Crimp-Solder CC Types for Flex.	324
8575	BNC	C25	Clamp Connectors	299	901-9601-3SF	SMA	C56	Braid Crimp-Solder CC Types for Flex.	324
86350	BNC	C25	Clamp Connectors	299	901-9602-1,-1SF	SMA	C56	Braid Crimp-Solder CC Types for Flex.	324
86425	BNC	C25	Clamp Connectors	299	901-9602-12SF	SMA	C56	Braid Crimp-Solder CC Types for Flex.	324
86850	BNC	C25	Clamp Connectors	299	901-9602-3,-3SF	SMA	C56	Braid Crimp-Solder CC Types for Flex.	324
901-10009-RFX	SMA	C53	Crimp/Solder CC Type for Flex. Cable	321	901-9610-12SF	SMA	C56	Braid Crimp-Solder CC Types for Flex.	324
901-10010-RFX	SMA	C53	Crimp/Solder CC Type for Flex. Cable	321	901-9610-1SF	SMA	C56	Braid Crimp-Solder CC Types for Flex.	324
901-10011	SMA	C53	Crimp/Solder CC Type for Flex. Cable	321	901-9610-3,-3SF	SMA	C56	Braid Crimp-Solder CC Types for Flex.	324
901-10012	SMA	C53	Crimp/Solder CC Type for Flex. Cable	321	901-9610-3SF	SMA	C56	Braid Crimp-Solder CC Types for Flex.	324
901-10013-RFX	SMA	C53	Crimp/Solder CC Type for Flex. Cable	321	901-9723	SMA	C48	Solder to Body/Pre-Asmbl. CC for SR	318
901-10014	SMA	C53	Crimp/Solder CC Type for Flex. Cable	321	901-9723-10	SMA	C48	Solder to Body/Pre-Asmbl. CC for SR	318
901-10015	SMA	C56	Braid Crimp-Solder CC Types for Flex.	324	901-9805-HP	SMA	C48	Solder to Body/Pre-Asmbl. CC for SR	318
901-10021-12SF	SMA	C53	Crimp/Solder CC Type for Flex. Cable	321	901-9808	SMA	C48	Solder to Body/Pre-Asmbl. CC for SR	318
901-10021-1SF	SMA	C53	Crimp/Solder CC Type for Flex. Cable	321	901-9808-1	SMA	C48	Solder to Body/Pre-Asmbl. CC for SR	318
					901-9808-2	SMA	C48	Solder to Body/Pre-Asmbl. CC for SR	318
					901-9852	SMA-Reverse Polarity	C58	Braid Crimp-Solder CC Types for Flex.	326

Amphenol Number	Series	Assembly Instruction	Description	Page No.	Amphenol Number	Series	Assembly Instruction	Description	Page No.
901-9857	SMA-Reverse Polarity	C59	Solder Types for .141 SR Cable	327	903-516P-71S	SMB	C62	Crimp Type Plug	330
901-9863	SMA-Reverse Polarity	C58	Braid Crimp-Solder CC Types for Flex.	326	903-517P-71A	SMB	C61	Crimp Type AP & A Bulkhead J	329
901-9866	SMA-Reverse Polarity	C59	Solder Types for .141 SR Cable	327	903-535P-71A	SMB	C61	Crimp Type AP & A Bulkhead J	329
901-9867-RFX	SMA	C47	Solder to Body/Pressfit Ins. for SR	317	903-536P-71S	SMB	C62	Crimp Type Plug	330
901-9868-RFX	SMA	C47	Solder to Body/Pressfit Ins. for SR	317	903-574P-71S	SMB	C62	Crimp Type Plug	330
901-9870	SMA	C53	Crimp/Solder CC Type for Flex.	321	903-575P-71S	SMB	C62	Crimp Type Plug	330
901-9871	SMA	C53	Crimp/Solder CC Type for Flex.	321	903-577P-51S	SMB	C62	Crimp Type Plug	330
901-9872	SMA	C53	Crimp/Solder CC Type for Flex.	321	903-577P-51S1	SMB	C62	Crimp Type Plug	330
901-9872	SMA	C57	Braid Crimp-Solder CC Types for Flex.	325	903-578P-51S	SMB	C62	Crimp Type Plug	330
901-9873	SMA	C53	Crimp/Solder CC Type for Flex.	321	903-578P-51S1	SMB	C62	Crimp Type Plug	330
901-9874	SMA	C53	Crimp/Solder CC Type for Flex.	321	903-579P-51S	SMB	C62	Crimp Type Plug	330
901-9875	SMA	C53	Crimp/Solder CC Type for Flex.	321	903-579P-51S1	SMB	C62	Crimp Type Plug	330
901-9876-RFX	SMA	C53	Crimp/Solder CC Type for Flex.	321	9350	BNC	C25	Clamp Connectors	299
901-9877	SMA	C57	Braid Crimp-Solder CC Types for Flex.	325	95700	BNC	C26a	3-Piece Crimp Angle P & Bulkhead J	301
901-9877-RFX	SMA	C53	Crimp/Solder CC Type for Flex.	321	908-41200	MMCX	C70	Straight Connector for Flex Cable	335
901-9879-RFX	SMA	C53	Crimp/Solder CC Type for Flex.	321	908-41300	MMCX	C70	Straight Connector for Flex Cable	335
901-9880-RFX	SMA	C53	Crimp/Solder CC Type for Flex.	321	908-41500	MMCX	C70	Straight Connector for Flex Cable	335
901-9881	SMA	C57	Braid Crimp-Solder CC Types for Flex.	325	908-42300	MMCX	C70	Straight Connector for Flex Cable	335
901-9881-RFX	SMA	C53	Crimp/Solder CC Type for Flex.	321	908-42500	MMCX	C70	Straight Connector for Flex Cable	335
901-9884	SMA-Reverse Polarity	C58	Braid Crimp-Solder CC Types for Flex.	326	908-41400	MMCX	C71	Straight Connector for SR Cable	336
901-9902	SMA	C53	Crimp/Solder CC Type for Flex.	321	908-41600	MMCX	C71	Straight Connector for SR Cable	336
901-9908	SMA-Reverse Polarity	C58	Braid Crimp-Solder CC Types for Flex.	326	908-43200	MMCX	C72	Right Angle Connectors for Flex.	337
901-9916	SMA	C53	Crimp/Solder CC Type for Flex.	321	908-43300	MMCX	C72	Right Angle Connectors for Flex.	337
901-9916	SMA	C57	Braid Crimp-Solder CC Types for Flex.	325	908-43500	MMCX	C72	Right Angle Connectors for Flex.	337
901-9990	SMA-Reverse Polarity	C58	Braid Crimp-Solder CC Types for Flex.	326	908-43400	MMCX	C73	Right Angle Connectors for Flex.	338
903-108J-71S	SMB	C60	Crimp Type P & Bulkhead J	328	908-43600	MMCX	C73	Right Angle Connectors for Flex.	338
903-152P-71S	SMB	C60	Crimp Type P & Bulkhead J	328	919-101P-51SX	MCX	C74	Straight Connector for Flex.	339
903-284P-52S	SMB	C60	Crimp Type P & Bulkhead J	328	919-101P-51S1X	MCX	C74	Straight Connector for Flex.	339
903-284P-52S1	SMB	C60	Crimp Type P & Bulkhead J	328	919-107J-51S1X	MCX	C74	Straight Connector for Flex.	339
903-285P-51S	SMB	C60	Crimp Type P & Bulkhead J	328	919-121P-51SX	MCX	C74	Straight Connector for Flex.	339
903-287P-51S	SMB	C60	Crimp Type P & Bulkhead J	328	919-131J-51SX	MCX	C74	Straight Connector for Flex.	339
903-288P-52A	SMB	C61	Crimp Type AP & A Bulkhead J	329	919-130P-51SX	MCX	C74	Straight Connector for Flex.	339
903-289P-51A	SMB	C61	Crimp Type AP & A Bulkhead J	329	919-128J-51SX	MCX	C74	Straight Connector for Flex.	339
903-289P-51A2	SMB	C61	Crimp Type AP & A Bulkhead J	329	919-129J-51SX	MCX	C74	Straight Connector for Flex.	339
903-291P-51A	SMB	C61	Crimp Type AP & A Bulkhead J	329	919-137P-51SX	MCX	C74	Straight Connector for Flex.	339
903-291P-51A1	SMB	C61	Crimp Type AP & A Bulkhead J	329	919-114J-51SX	MCX	C75	Straight connector for SR Cable	340
903-362P-52A1	SMB	C61	Crimp Type AP & A Bulkhead J	329	919-120P-51SX	MCX	C75	Straight connector for SR Cable	340
903-367P-51A	SMB	C61	Crimp Type AP & A Bulkhead J	329	919-102P-51AX	MCX	C76	Right Angle Plugs for SR Cable	341
903-367P-51A1	SMB	C61	Crimp Type AP & A Bulkhead J	329	919-103P-51AX	MCX	C76	Right Angle Plugs for SR Cable	341
903-367P-51A2	SMB	C61	Crimp Type AP & A Bulkhead J	329	919-104P-51AX	MCX	C77	Right Angle Plugs & Crimp Type	342
903-368P-51A	SMB	C61	Crimp Type AP & A Bulkhead J	329	919-104P-51A1X	MCX	C77	Right Angle Plugs & Crimp Type	342
903-368P-51A1	SMB	C61	Crimp Type AP & A Bulkhead J	329	919-122P-51AX	MCX	C77	Right Angle Plugs & Crimp Type	342
903-369P-51A	SMB	C61	Crimp Type AP & A Bulkhead J	329	919-136P-51AX	MCX	C77	Right Angle Plugs & Crimp Type	342
903-369P-51A2	SMB	C61	Crimp Type AP & A Bulkhead J	329	919-136P-51A2X	MCX	C77	Right Angle Plugs & Crimp Type	342
903-371P-51S	SMB	C60	Crimp Type P & Bulkhead Jacks	328					
903-401P-51S	SMB	C60	Crimp Type Plugs & Bulkhead J	328					
903-422J-51A	SMB	C61	Crimp Type AP & A Bulkhead J	329					
903-429P-51A	SMB	C61	Crimp Type AP & A Bulkhead J	329					
903-495P-71A	SMB	C61	Crimp Type AP & A Bulkhead J	329					
903-502P-71S	SMB	C60	Crimp Type P & Bulkhead J	328					
903-505J-51S	SMB	C60	Crimp Type P & Bulkhead J	328					
903-505J-51S1	SMB	C60	Crimp Type P & Bulkhead J	328					
903-508P-51S	SMB	C62	Crimp Type Plug	330					
903-509P-51S	SMB	C62	Crimp Type Plug	330					



**Aerospace Products**

This publication is intended to illustrate and briefly describe the Amphenol/Pyle-National Interconnection Product Lines. The sections of this brochure are by family types. Each type of connector is available in a variety of sizes and configurations. These detailed catalogs include dimensional drawings, insert patterns and how to order information. For a product catalog, call **(800) 678-0141**



**Chip Connectors**

Also call IC card, Integrated Circuit card, Smart card, as well as a number of application specific titles... a chip card is basically a standard plastic "credit card" with an integrated circuit silicon chip embedded in a die that is milled out of the plastic. Eight gold-plated pads are connected to the IC. These pads are the card's interface with the outside world. For a product catalog, call **(734) 451-6400** in the US or **(49-7) 13.19.29.322** in Europe.

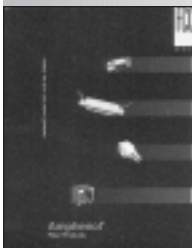

**Filtered Connectors**

Amphenol Canada Corp., a subsidiary of Amphenol Corporation, is an international leader in the manufacture of Filtered Connectors and Specialty Interconnect Devices, and has been pioneering EMI and EMP technologies for more than 30 years. EMI/EMP filter connector products which are used in Commercial, Industrial, Communications, Military and Aerospace applications worldwide. For a product catalog, call **(416) 291-4401**



**Fiber Optic Products**

Amphenol is a premier manufacturer of optical interconnect products. Headquartered in Lisle, Illinois. Amphenol offers the industry's most complete line of passive interconnect products from our universal termination system to the latest wave length division multi-plexers. For a product catalog, call **(800) 944-6446**



### D-Subminiature

Amphenol's line of D-Subminiature rack and panel connectors is part of an industry standard for applications requiring reliable, rugged, high density connectors. These connectors are designed to accommodate rack and panel, cable to panel and cable to cable applications. Amphenol D-Subminiature connectors can be used in commercial, industrial or military markets. Applications include Business equipment, Electronic office systems, Data communication, Medical equipment and SCSI interfacing. For a product catalog, call **(416) 291-4401**



### Hardline/SemiFlex

Amphenol's Broadband Connector Division is setting the standard for hardline connectors in the CATV industry. Our unique three-piece hardline design provides exceptional electrical performance, long term reliability and installation-friendly features. For a product catalog, call **(800) 881-9913**



### Spectra•Strip

In applications ranging from large scale massively parallel processors (MPP) and symmetric multiple processors (SMP) servers to telephone digital cross-connects to high speed automatic test equipment. Amphenol Spectra•Strip offers a wide variety of products and accessories for all types of applications like: Ribbon and Micro-ribbon connectors, Sockets, Headers and Board mount connectors. For a product catalog, call **(800) 846-6400**

