

ATLANTIC VERSION TERMINATOR INTERFACE ADAPTER	PART NUMBER	REVISION	DESCRIPTION	FEED TYPE	APPLICATOR STYLE CONVERSION CHART					
					CONVERT TO	PART NUMBERS REQUIRED				
	2150005-2	G	FINE CRIMP HEIGHT ADJUST	PNEUMATIC	-	-	-	-	-	-
					SERVO LATCH PLATE	2119951-1	1901697-1	8-2150005-5	-	2168400-7 (QUANTITY 2)
					SMART APPLICATOR	2161326-1	-	8-2150005-4	-	-
	2150005-5	G	FINE CRIMP HEIGHT ADJUST	SERVO LATCH PLATE ⁴	-	-	-	-	-	-
						PNEUMATIC FEED	2119950-1	2119792-2	-	2119641-1
2150005-6	G	NON-CRIMP HEIGHT ADJUST	SERVO LATCH PLATE ¹¹	-	-	-	-	-	-	
2150005-7	G	FINE CRIMP HEIGHT ADJUST	NONE	-	-	-	-	-	-	
7-2150005-7	E	CRIMP TOOLING KIT	-	-	-	-	-	-	-	

APPLICATOR DATA		
CRIMP	SIZE	TYPE
WIRE	4.06 mm [.160]	F
INSUL	5.33 mm [.210]	OV
APPL INSTRUCTIONS 408-10390		

TERMINAL DATA: TE TERMINAL		TE CRIMP SPECIFICATION	
TERMINAL NAME: RINGTONGUE			
WIRE STRIP LENGTH		INSULATION DIAMETER RANGE	
5.00-5.50 mm [.197-.217 IN]		Ø3.40-4.70 mm [.134-.185 IN]	
TERMINAL APPLICATION SPECIFICATION	114-18022	-	-
TERMINALS APPLIED ¹⁰			
TE TERMINAL	TE TERMINAL	TE TERMINAL	TE TERMINAL
928927-2	928927-4		

WIRE SIZE	CRIMP HEIGHT mm [INCH]	CRIMP HEIGHT REFERENCE SETTING
4.00mm2	2.86 +/- 0.05 [.113 +/- .002]	7.0
3.50mm2	2.78 +/- 0.05 [.109 +/- .002]	8.0
3.00mm2	2.70 +/- 0.05 [.106 +/- .002]	8.9

- ¹ RECOMMENDED SPARE PARTS
- ² GREASE BEARING SURFACES LIGHTLY
- 3. LUBRICATE DAILY PER THE APPLICATOR INSTRUCTION SHEET SUPPLIED WITH THE APPLICATOR.
- ⁴ APPLICATOR SPECIFIC DATA TO BE ENTERED INTO BLANK MEMORY CHIP AT ASSEMBLY. SEE BELOW FOR PART NUMBER:
 PNEUMATIC FEED WITH "SMART APPLICATOR" CONVERSION: 8-2150005-4
 SERVO FEED WITH "FINE CRIMP HEIGHT ADJUST": 8-2150005-5
 SERVO FEED WITH "NON-CRIMP HEIGHT ADJUST": 8-2150005-6
- 5. ADJUSTMENT OF THE STRIPPER MAY BE REQUIRED WHEN MOVING THE APPLICATOR BETWEEN BENCH AND LEADMAKER APPLICATIONS.
- ⁶ APPLY PART NUMBER 1-23419-5 LOCTITE TO THREADS OF ITEMS 62. APPLY PART NUMBER 2-23419-6 LOCTITE TO THREADS OF ITEMS 242. FOR -6 ONLY APPLY PART NUMBER 1-23419-5 LOCTITE TO THREADS OF ITEMS 37.
- ⁷ GREASE THREADS, GROOVE AND O-RING ON ITEMS 35 & 252.
- ⁸ MAGNET, ITEM 166 MUST BE ORIENTED CORRECTLY IN ORDER TO PROPERLY ACTUATE THE COUNTER.
- ⁹ CRIMP HEIGHT REFERENCE SETTING WAS THE SETTING USED WHEN THE APPLICATOR WAS QUALIFIED AT THE FACTORY. ADJUSTMENT MAY BE NECESSARY WHEN RUNNING APPLICATOR IN THE FIELD.
- ¹⁰ TERMINAL PITCH NOT COMPATIBLE WITH MECHANICAL FEED.
- ¹¹ WHEN ASSEMBLING -6 NON-CRIMP HEIGHT ADJUST APPLICATOR USE SHIM PACK 2119957-2 TO ALIGN APPLICATOR'S MAXIMUM WIRE CRIMP HEIGHT AT NORMAL TERMINATOR SHUT HEIGHT
- ¹² CUT TO LENGTH AT ASSEMBLY.

***WARNING**
 ON INSTALLATION, SET WIRE DISC, ITEM 40 TO LARGEST WIRE SIZE SETTING. USE OF SETTINGS BELOW MINIMUM REQUIRED CRIMP HEIGHT SETTING WILL CAUSE DAMAGE TO CRIMP TOOLING.

ATLANTIC VERSION
 Shown on sheets 1 of 4 & 2 of 4
 (Pacific version shown on sheets 3 of 4 & 4 of 4)

SET UP GAUGE	LOC	DIST	REVISIONS					
2119599-2	A	66	#	LTN	DESCRIPTION	DATE	DWN	APVD
			E		ECR-14-014791	03OCT2014	LG	GB
			F		ECR-16-006299	29APR2016	KH	LZ
			G		ECR-16-016168	15NOV2016	TB	TE

-	-	1	-	-	2119957-2	APPLICATOR SHIM PACK	260
-	1	-	1	1	8-21084-0	O-RING, .676 ID, .070 DIA. MAT.	252
-	-	-	-	1	1803259-1	BUSHING, FLANGED	250
-	-	-	-	1	2119640-1	PUSH ROD, AIR FEED	249
-	-	-	-	1	2119641-1	FEED CAM, AIR FEED	248
-	1	-	1	1	2119798-1	DETENT PIN	247
-	1	-	1	1	1-22279-3	SPRING, COMPRESSION	246
-	-	1	-	-	2119759-1	RAM, AMP STYLE, END FEED, NON-ADJUST	245
-	1	1	1	1	2119082-9	CAM, SNAIL, INSULATION ADJUSTMENT	244
-	1	1	1	1	2079764-1	WASHER, WAVE SPRING, CREST-TO-CREST	243
-	1	1	1	1	2119083-1	RETAINER, INSULATION DIAL	242
-	-	2	2	-	2168400-7	SHCS, LOW HEAD, RoHS, M5 X 10	240
-	-	-	-	1	2063440-2	AIR FEED MODULE	238
-	-	1	1	-	2119740-2	TAG, IDENTIFICATION	213
-	-	REFREF	-	-	1901697-1	FEED FINGER ASSEMBLY, EF	183
-	-	-	-	2	21045-3	RING, RETAIN, EXTERN, 3/16 CRESCENT	172
-	1	1	1	1	994969-1	MAGNET, RARE EARTH HIGH ENERGY	166
-	REFREFREFREF	-	-	-	994970-2	COUNTER, MAGNETIC	164
-	-	-	-	1	240638-1	SPRING, FEED FINGER	163
-	-	-	-	1	3-23627-7	PIN, RETAIN, GRVD, 3/16 X .854	137
-	-	REFREF	-	-	SEE NOTE 4	MEMORY CHIP, PROGRAMMED	135
-	-	1	1	-	1633743-1	SERVO FEED LATCH ASM	133
-	1	1	1	1	455888-5	SPACER, CRIMPER	82
-	1	1	1	1	2119956-2	DOCUMENTATION PACKAGE	71
-	2	2	2	2	2-18032-2	SCR, SET, FLT POINT M3 X 10.0	70
-	1	-	-	1	2119740-1	TAG, IDENTIFICATION	67
-	2	2	2	2	2168078-1	SCREW, DRIVE, RH, RoHS, 2 x .188	66
-	1	-	1	1	2119793-1	LIMITER, ADJUSTMENT BOLT	63
-	3	-	3	3	992763-5	SCR, SET, SOC, CONE POINT, M3 x 4.0	62
-	1	1	1	1	2079383-4	SCR, BHSC, RoHS (M4 X 8)	60
-	4	4	4	4	2168400-4	SHCS, LOW HEAD, RoHS, M4 X 8	57
-	2	2	2	2	2168083-9	SCR, SKT HD CAP, RoHS, M4 X 20	56
-	2	2	2	2	5018030-2	NUT, HEX, REG, RoHS, M4	55
-	2	2	2	2	5018030-1	NUT, HEX, REG, RoHS, M3	54
-	2	2	2	2	986965-8	NUT, LOCK, HEX, TORQUE (M4)	53
-	-	-	-	1	2119792-2	PAWL, EF, AIR	51
-	-	-	-	1	18023-9	SCR, SKT HD CAP M4 X 6.0	49
-	1	1	1	1	2119655-5	APPLICATOR BASIC ASSEMBLY, EF	46
-	1	-	1	1	2119369-1	RAM, AMP STYLE, END FEED	44
-	1	1	1	1	2079383-7	SCR, BHSC, RoHS (M8 X 25)	41
-	1	-	1	1	2119645-1	DISC, NUMBERED FA WIRE ADJUSTMENT	40
-	1	-	1	1	2119957-1	APPLICATOR SHIM PACK	39
-	1	1	1	1	2119644-2	RAM WASHER, PRECISION	38
-	1	1	1	1	2119085-1	FA HEAD, ATLANTIC STYLE	37
-	1	-	1	1	2119092-1	BOLT, ADJUSTMENT	35
-	8	8	8	8	1-18028-2	WASHER, FLAT, REG M4	33
-	2	2	2	2	2168083-9	SCR, SKT HD CAP, RoHS, M4 X 20	31
-	2	2	2	2	1-2168083-0	SCR, SKT HD CAP, RoHS, M4 X 10	29
-	1	1	1	1	240639-1	STRIPPER (MACHINING)	27
-	2	2	2	2	1320906-1	STUD, THREADED	25
-	1	1	1	1	1752371-5	PLATE, STRIP GUIDE	24
-	2	2	2	2	2-22281-3	SPRING, COMPRESSION	22
-	1	1	1	1	1752373-4	DRAG	20
-	1	1	1	1	1-1901696-0	STRIP GUIDE, REAR	19
-	1	1	1	1	1-1901695-0	STRIP GUIDE, FRONT	18
-	4	4	4	4	1-2079383-1	SCR, BHSC, RoHS (M6 X 12)	17
-	1	1	1	1	4-240641-6	SPACER	16
-	1	1	1	1	240644-1	PLATE, REAR SHEAR	11
-	-	-	-	-	-	-	10
-	1	1	1	1	7-690482-0	PLATE, FRONT SHEAR	9
-	1	1	1	1	1333223-5	ANVIL, COMBINATION	8
-	1	1	1	1	1-2217206-4	BLADE, SLUG	7
-	1	1	1	1	6-240641-0	SPACER	5
-	1	1	1	1	3-238009-0	BLOCK, FL CRIMPER SPACER	4
-	1	1	1	1	1-1633963-3	CRIMPER, INSULATION OVERLAP PREMIUM	3
-	1	1	1	1	1-455888-6	SPACER, CRIMPER	2
-	1	1	1	1	456414-9	CRIMPER, WIRE	1

DIMENSIONS:		TOLERANCES UNLESS OTHERWISE SPECIFIED:		DRAWING NO		NAME	
mm	0 PLC ±	1 PLC ±	2 PLC ±	3 PLC ±	4 PLC ±	5 PLC ±	6 PLC ±
	ANGLES	FINISH					
MATERIAL				WEIGHT			

CHK	T. YIN	01FEB2012	TE Connectivity Harrisburg, PA 17105-3608			
CHK	G. BAILEY	01FEB2012				
APVD	S. XI	01FEB2012				
PRODUCT SPEC						
APPLICATION SPEC			SIZE	CAGE CODE	DRAWING NO	RESTRICTED TO
			A1	00779	©=2150005	
Customer Accessible Production Drawing			SCALE	1:1	SHEET	1 of 4
			REV	G		

LOC	DIST	REV	DATE	BY	APPV
A	66				
REVISIONS			DESCRIPTION	DATE	BY
			SEE SHEET 1		

FEED TYPE

PNEUMATIC

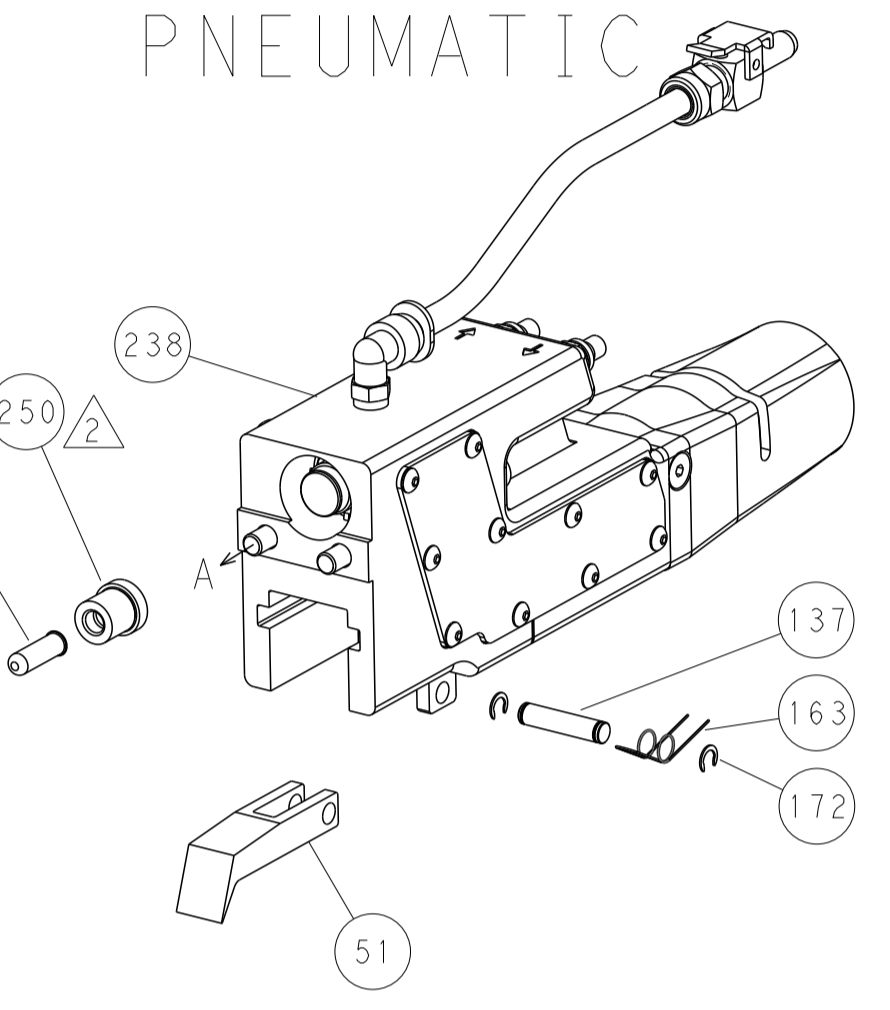

SERVO LATCH PLATE

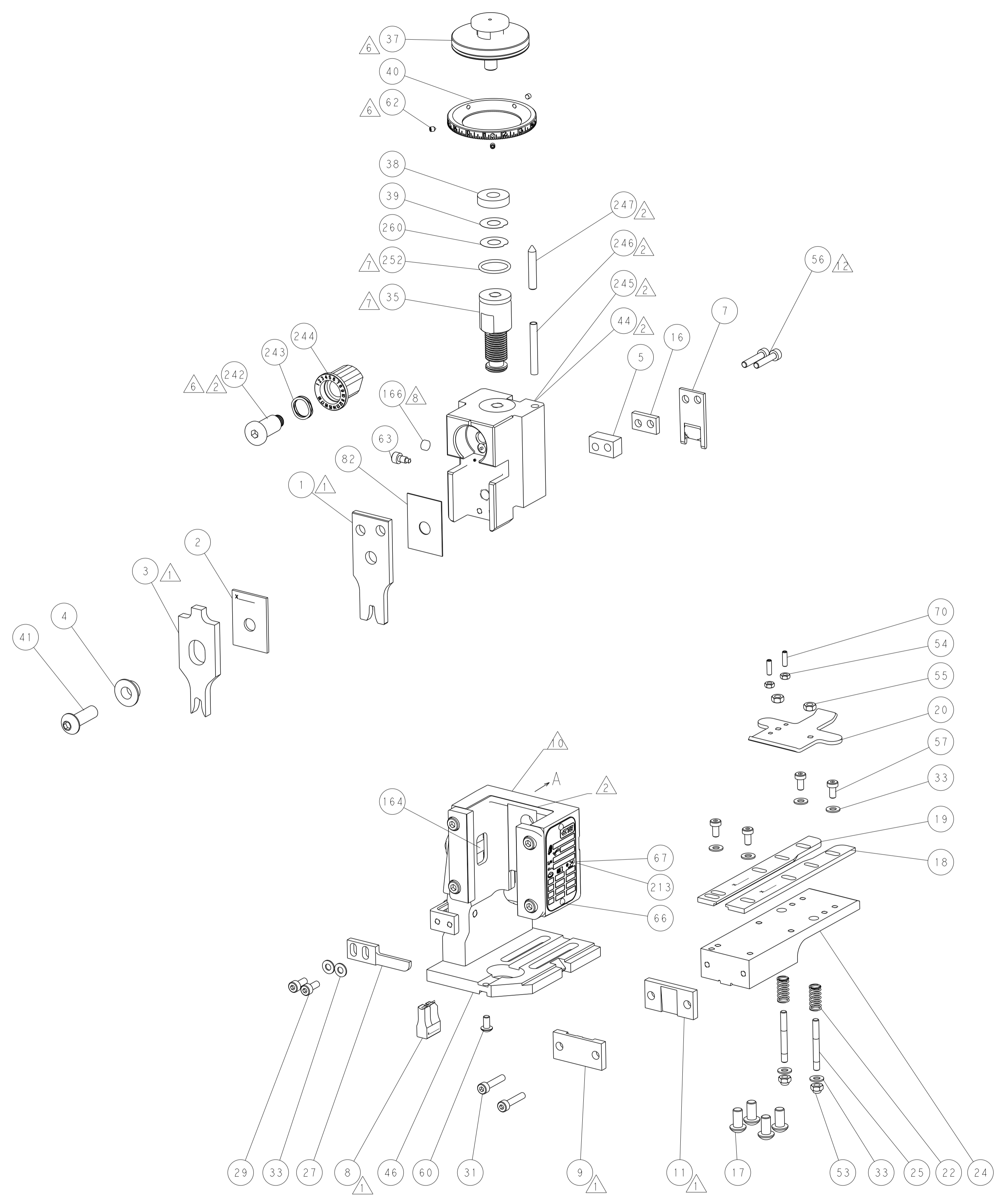
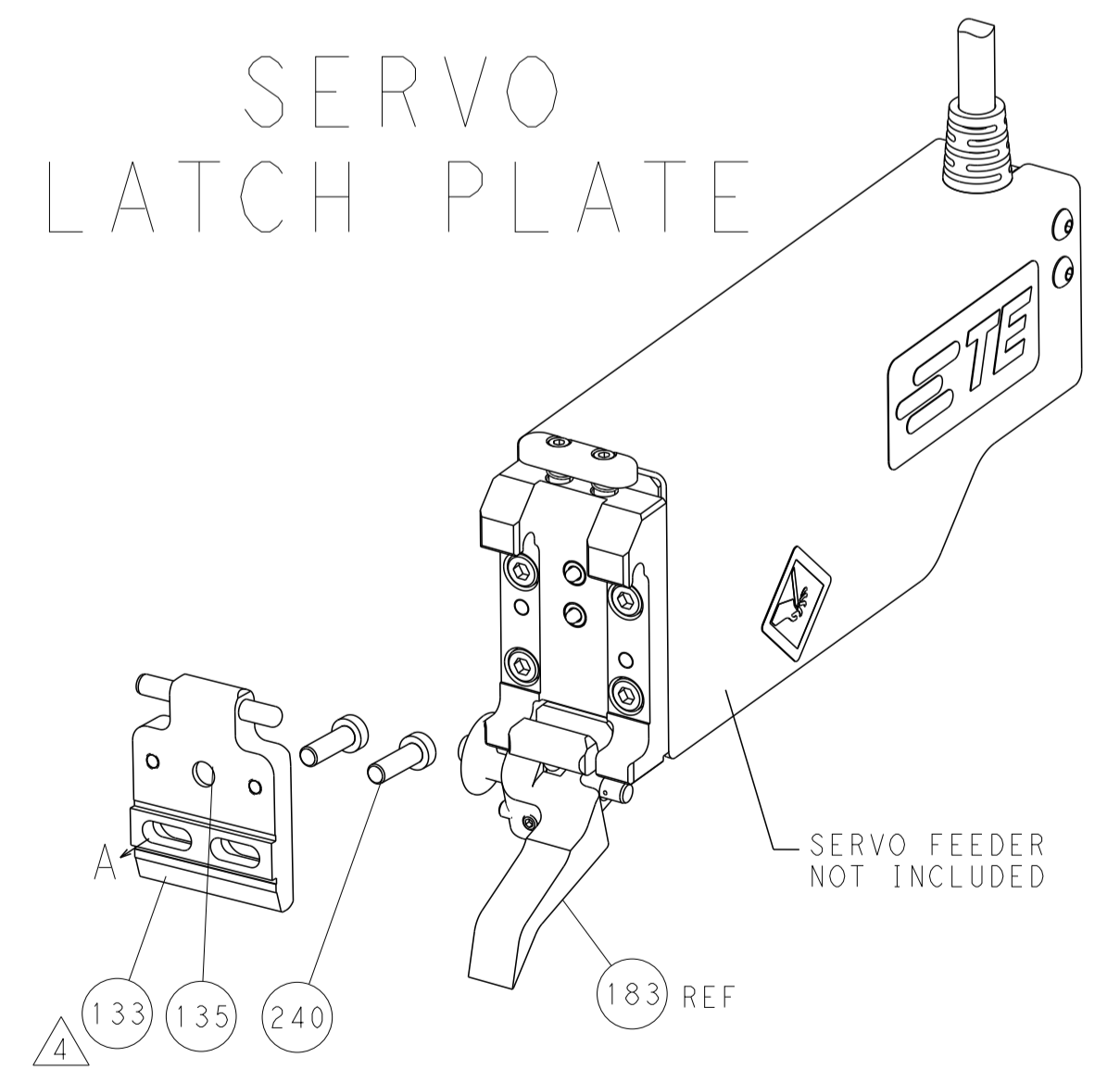

CAM POSITION

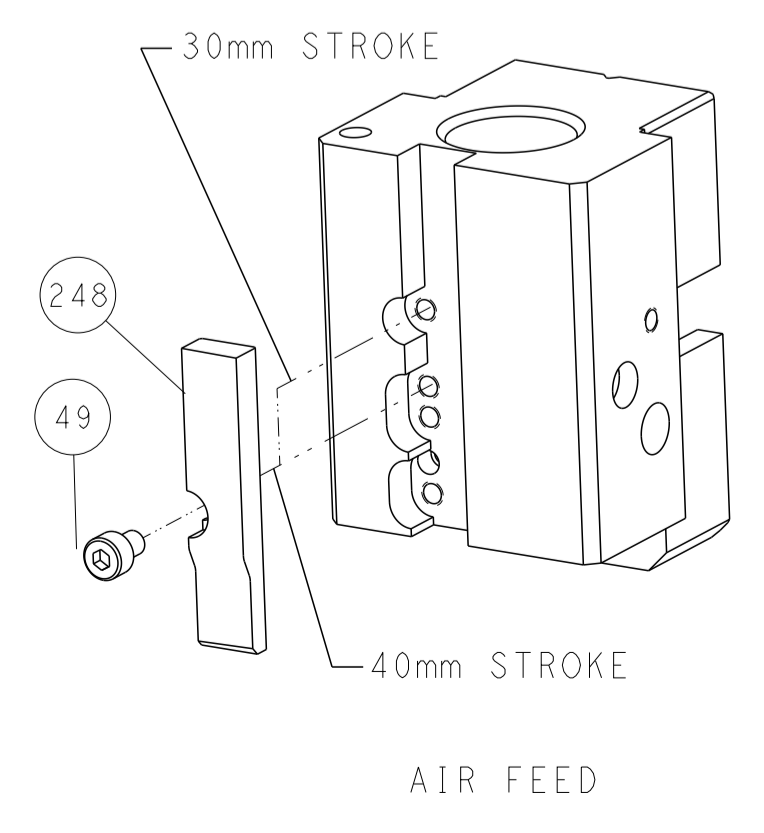

AIR FEED

ATLANTIC VERSION
 Shown on sheets 1 of 4 & 2 of 4
 (Pacific version shown on sheets 3 of 4 & 4 of 4)

DIMENSIONS:		TOLERANCES UNLESS OTHERWISE SPECIFIED:		DWG: Y. YIN 01FEB2012		TE Connectivity	
mm		0 PLC ±		CHK: G. BAILEY 01FEB2012		Harrisburg, PA 17105-3608	
Ø		1 PLC ±		APPV: S. XI 01FEB2012		NAME: OCEAN END FEED APPLICATOR	
H		2 PLC ±		PRODUCT SPEC		SIZE: CAGE CODE: DRAWING NO:	
D		3 PLC ±		APPLICATION SPEC		RESTRICTED TO:	
R		4 PLC ±		WEIGHT		A1 00779 ©=2150005	
ANGLES		FINISH		Customer Accessible Production Drawing		SCALE: 1:1 SHEET 2 OF 4 REV G	

PACIFIC VERSION TERMINATOR INTERFACE ADAPTER	PART NUMBER	REVISION	DESCRIPTION	FEED TYPE	APPLICATOR STYLE CONVERSION CHART					
					CONVERT TO	PART NUMBERS REQUIRED				
	2-2150005-2	G	FINE CRIMP HEIGHT ADJUST	PNEUMATIC	-	-	-	-	-	-
					SERVO LATCH PLATE	2119951-1	1901697-1	8-2150005-5	-	2168400-7 (QUANTITY 2)
					SMART APPLICATOR	2161326-1	-	8-2150005-4	-	-
	2-2150005-5	G	FINE CRIMP HEIGHT ADJUST	SERVO LATCH PLATE ⁴	-	-	-	-	-	-
					PNEUMATIC FEED	2119950-1	2119792-2	-	2119641-2	2063440-2
2-2150005-7	G	FINE CRIMP HEIGHT ADJUST	NONE	-	-	-	-	-	-	-
7-2150005-7	E	CRIMP TOOLING KIT	-	-	-	-	-	-	-	-

APPLICATOR DATA		
CRIMP	SIZE	TYPE
WIRE	4.06 mm [1.60]	F
INSUL	5.33 mm [2.10]	OV
APPL INSTRUCTIONS 408-10390		

TERMINAL DATA: TE TERMINAL		TE CRIMP SPECIFICATION
TERMINAL NAME: RINGTONGUE		
WIRE STRIP LENGTH		INSULATION DIAMETER RANGE
5.00-5.50 mm [1.97-.217 IN]		∅3.40-4.70 mm [1.34-.185 IN]
TERMINAL APPLICATION SPECIFICATION	114-18022	-
TERMINALS APPLIED ¹⁰		
TE TERMINAL	TE TERMINAL	TE TERMINAL
928927-2	928927-4	

WIRE SIZE	CRIMP HEIGHT mm [INCH]	CRIMP HEIGHT REFERENCE SETTING ⁹
4.00mm2	2.86 +/- 0.05 [1.113 +/- .002]	7.0
3.50mm2	2.78 +/- 0.05 [1.109 +/- .002]	8.0
3.00mm2	2.70 +/- 0.05 [1.106 +/- .002]	8.9

- RECOMMENDED SPARE PARTS
- GREASE BEARING SURFACES LIGHTLY
- 3. LUBRICATE DAILY PER THE APPLICATOR INSTRUCTION SHEET SUPPLIED WITH THE APPLICATOR.
- ⁴ APPLICATOR SPECIFIC DATA TO BE ENTERED INTO BLANK MEMORY CHIP AT ASSEMBLY. SEE BELOW FOR PART NUMBER:
 PNEUMATIC FEED WITH "SMART APPLICATOR" CONVERSION: 8-2150005-4
 SERVO FEED WITH "FINE CRIMP HEIGHT ADJUST": 8-2150005-5
- 5. ADJUSTMENT OF THE STRIPPER MAY BE REQUIRED WHEN MOVING THE APPLICATOR BETWEEN BENCH AND LEADMAKER APPLICATIONS.
- ⁶ APPLY PART NUMBER 1-23419-5 LOCTITE TO THREADS OF ITEMS 62.
 APPLY PART NUMBER 2-23419-6 LOCTITE TO THREADS OF ITEMS 242.
- ⁷ GREASE THREADS, GROOVE AND O-RING ON ITEMS 139 & 153.
- ⁸ MAGNET, ITEM 166 MUST BE ORIENTED CORRECTLY IN ORDER TO PROPERLY ACTUATE THE COUNTER.
- ⁹ CRIMP HEIGHT REFERENCE SETTING WAS THE SETTING USED WHEN THE APPLICATOR WAS QUALIFIED AT THE FACTORY. ADJUSTMENT MAY BE NECESSARY WHEN RUNNING APPLICATOR IN THE FIELD.
- ¹⁰ TERMINAL PITCH NOT COMPATIBLE WITH MECHANICAL FEED.
- ¹¹ CUT TO LENGTH AT ASSEMBLY.

***WARNING**
 ON INSTALLATION, SET WIRE DISC, ITEM 40 TO LARGEST WIRE SIZE SETTING. USE OF SETTINGS BELOW MINIMUM REQUIRED CRIMP HEIGHT SETTING WILL CAUSE DAMAGE TO CRIMP TOOLING.

PACIFIC VERSION
 Shown on sheets 3 of 4 & 4 of 4
 (Atlantic version shown on sheets 1 of 4 & 2 of 4)

SET UP GAUGE	LOC	DIST	REVISIONS					
2119599-2	A	66	P	LTN	DESCRIPTION	DATE	OWN	APVD
			-	-	SEE SHEET 1	-	-	-

-	1	1	1	2119782-1	FINE ADJUST HEAD ASM, PACIFIC STYLE	251
-	-	-	1	1803259-1	BUSHING, FLANGED	250
-	-	-	1	2119640-1	PUSH ROD, AIR FEED	249
-	1	1	1	1-22279-3	SPRING, COMPRESSION	246
-	1	1	1	2119082-9	CAM, SNAIL, INSULATION ADJUSTMENT	244
-	1	1	1	2079764-1	WASHER, WAVE SPRING, CREST-TO-CREST	243
-	1	1	1	2119083-1	RETAINER, INSULATION DIAL	242
-	-	2	-	2168400-7	SHCS, LOW HEAD, RoHS, M5 X 10	240
-	-	-	1	2063440-2	AIR FEED MODULE	238
-	-	1	-	2119740-2	TAG, IDENTIFICATION	213
-	4	4	4	2079383-9	SCR, BHSC, RoHS (M6 X 20)	186
-	-	REF	-	1901697-1	FEED FINGER ASSEMBLY, EF	183
-	-	-	2	21045-3	RING, RETAIN, EXTERN, 3/16 CRESCENT	172
-	1	1	1	994969-1	MAGNET, RARE EARTH HIGH ENERGY	166
-	REF	REF	REF	994970-2	COUNTER, MAGNETIC	164
-	-	-	1	240638-1	SPRING, FEED FINGER	163
-	1	1	1	8-21084-1	O-RING, .801 ID, .070 DIA. MAT.	153
-	-	-	1	2119641-2	FEED CAM, AIR FEED	152
-	1	1	1	2119798-2	DETENT PIN	145
-	1	1	1	2079383-8	SCR, BHSC, RoHS (M4 X 16)	144
-	1	1	1	2119655-6	APPLICATOR BASIC ASSEMBLY, EF	141
-	1	1	1	2119651-1	RAM, ASIAN STYLE, END FEED	140
-	1	1	1	2119092-2	BOLT, ADJUSTMENT	139
-	-	-	1	3-23627-7	PIN, RETAIN, GRVD, 3/16 X .854	137
-	-	REF	-	SEE NOTE 4	MEMORY CHIP, PROGRAMMED	135
-	-	1	-	1633743-1	SERVO FEED LATCH ASM	133
-	1	1	1	455888-5	SPACER, CRIMPER	82
-	1	1	1	2119956-2	DOCUMENTATION PACKAGE	71
-	2	2	2	2-18032-2	SCR, SET, FLT POINT M3 X 10.0	70
-	1	-	1	2119740-1	TAG, IDENTIFICATION	67
-	2	2	2	2168078-1	SCREW, DRIVE, RH, RoHS, 2 x .188	66
-	1	1	1	2119793-1	LIMITER, ADJUSTMENT BOLT	63
-	3	3	3	992763-5	SCR, SET, SOC, CONE POINT, M3 X 4.0	62
-	4	4	4	2168400-4	SHCS, LOW HEAD, RoHS, M4 X 8	57
-	2	2	2	2168083-9	SCR, SKT HD CAP, RoHS, M4 X 20	56
-	2	2	2	5018030-2	NUT, HEX, REG, RoHS, M4	55
-	2	2	2	5018030-1	NUT, HEX, REG, RoHS, M3	54
-	2	2	2	986965-8	NUT, LOCK, HEX, TORQUE (M4)	53
-	-	-	1	2119792-2	PAWL, EF, AIR	51
-	-	-	1	18023-9	SCR, SKT HD CAP M4 X 6.0	49
-	1	1	1	2079383-7	SCR, BHSC, RoHS (M8 X 25)	41
-	1	1	1	2119645-1	DISC, NUMBERED FA WIRE ADJUSTMENT	40
-	1	1	1	2119957-1	APPLICATOR SHIM PACK	39
-	1	1	1	2119644-2	RAM WASHER, PRECISION	38
-	8	8	8	1-18028-2	WASHER, FLAT, REG M4	33
-	2	2	2	2168083-9	SCR, SKT HD CAP, RoHS, M4 X 20	31
-	2	2	2	1-2168083-0	SCR, SKT HD CAP, RoHS, M4 X 10	29
-	1	1	1	240639-1	STRIPPER (MACHINING)	27
-	2	2	2	1320906-1	STUD, THREADED	25
-	1	1	1	1752371-5	PLATE, STRIP GUIDE	24
-	2	2	2	2-22281-3	SPRING, COMPRESSION	22
-	1	1	1	1752373-4	DRAG	20
-	1	1	1	1-1901696-0	STRIP GUIDE, REAR	19
-	1	1	1	1-1901695-0	STRIP GUIDE, FRONT	18
-	1	1	1	4-240641-6	SPACER	16
-	1	1	1	240644-1	PLATE, REAR SHEAR	11
-	-	-	-	-	-	10
-	1	1	1	7-690482-0	PLATE, FRONT SHEAR	9
-	1	1	1	1333223-5	ANVIL, COMBINATION	8
-	1	1	1	1-2217206-4	BLADE, SLUG	7
-	1	1	1	6-240641-0	SPACER	5
-	1	1	1	3-238009-0	BLOCK, FL CRIMPER SPACER	4
-	1	1	1	1-1633963-3	CRIMPER, INSULATION OVERLAP PREMIUM	3
-	1	1	1	1-455888-6	SPACER, CRIMPER	2
-	1	1	1	456414-9	CRIMPER, WIRE	1

DIMENSIONS:		TOLERANCES UNLESS OTHERWISE SPECIFIED:		DRAWN		DATE	
mm	0 PLC	±	01FEB2012	Y. YIN	01FEB2012	TE Connectivity	
	1 PLC	±	01FEB2012	G. BAILEY	01FEB2012	Harrisburg, PA 17105-3608	
	2 PLC	±		NAME		OCEAN END FEED APPLICATOR	
	3 PLC	±		PRODUCT SPEC			
	4 PLC	±		APPLICATION SPEC			
	5 PLC	±		SIZE		A1 00779 C=2150005	
	ANGLES	±		WEIGHT		Customer Accessible Production Drawing	
	FINISH	±		SCALE		1:1 SHEET 3 OF 4 REV G	

LOC	DIST	REVISIONS			
P	LTN	DESCRIPTION	DATE	OWN	APVD
A	66	SEE SHEET 1	-	-	-

FEED TYPE

PNEUMATIC

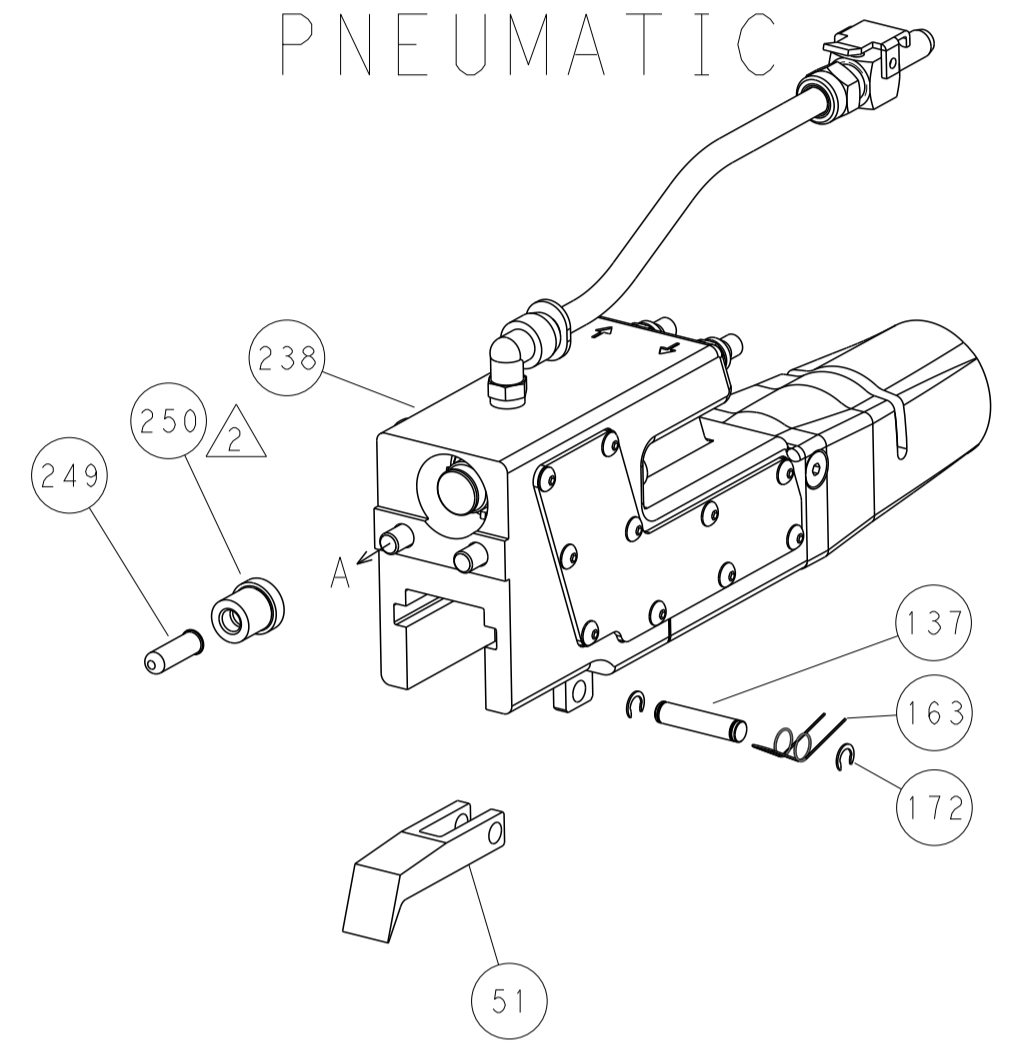

SERVO LATCH PLATE

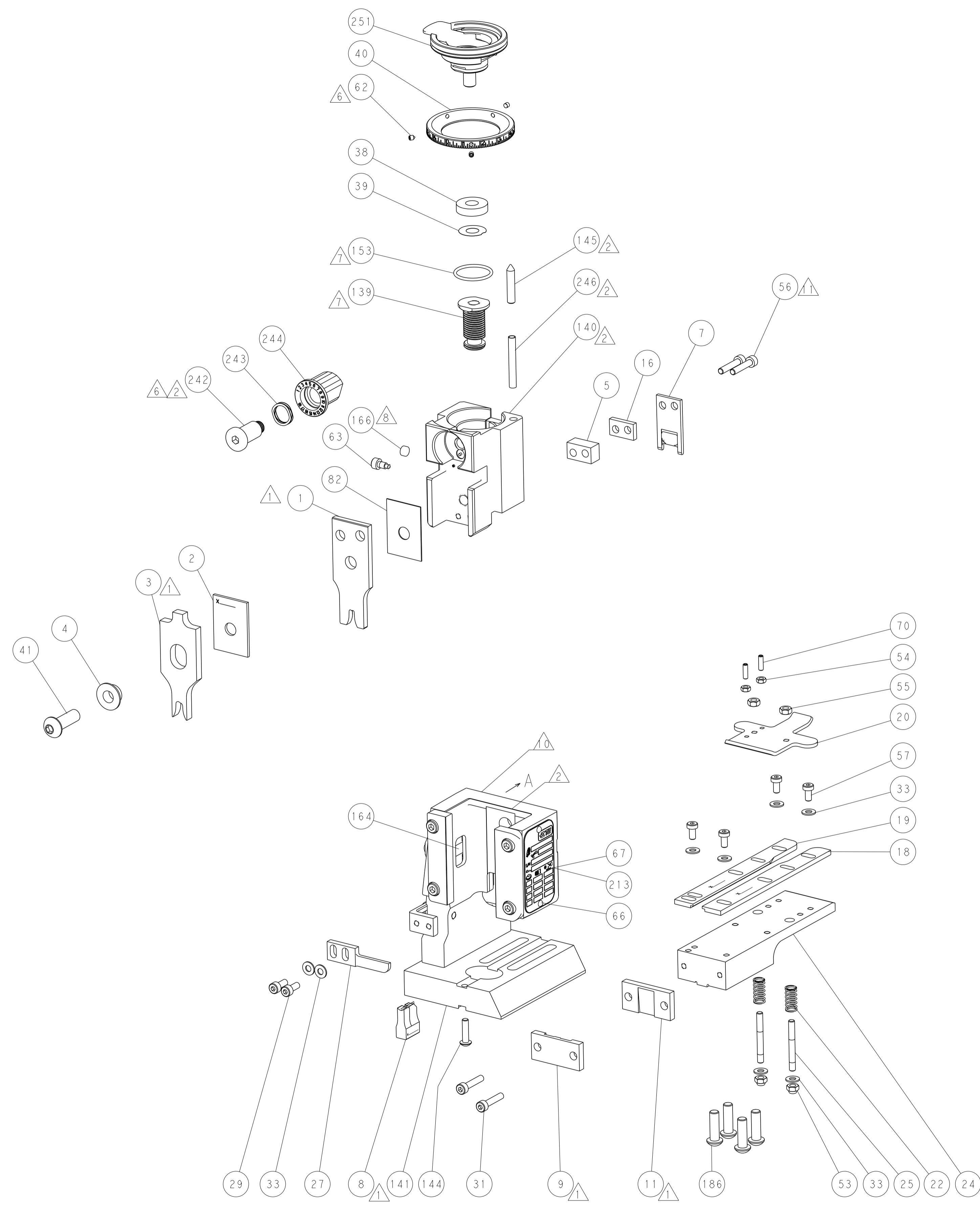
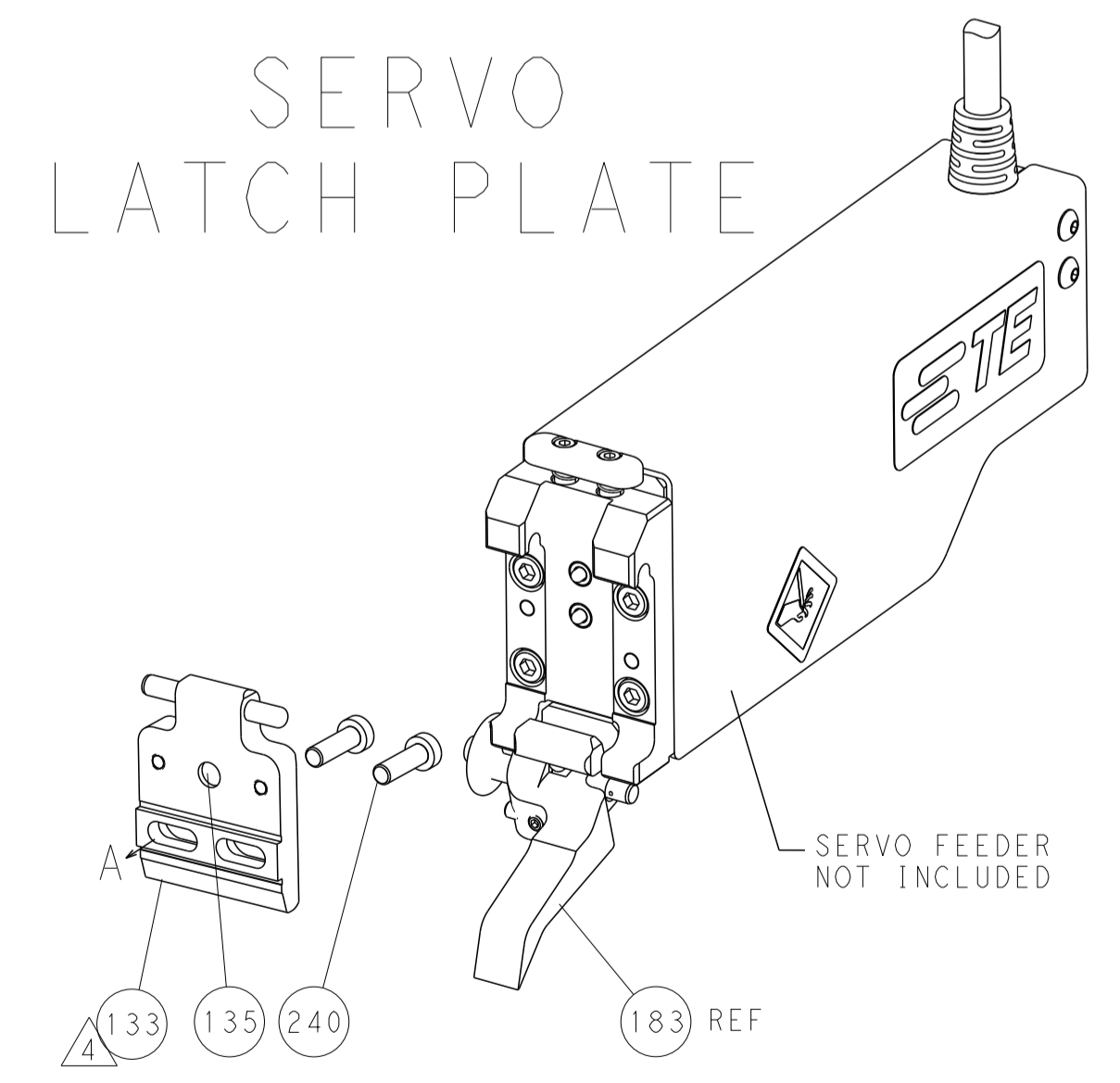

CAM POSITION

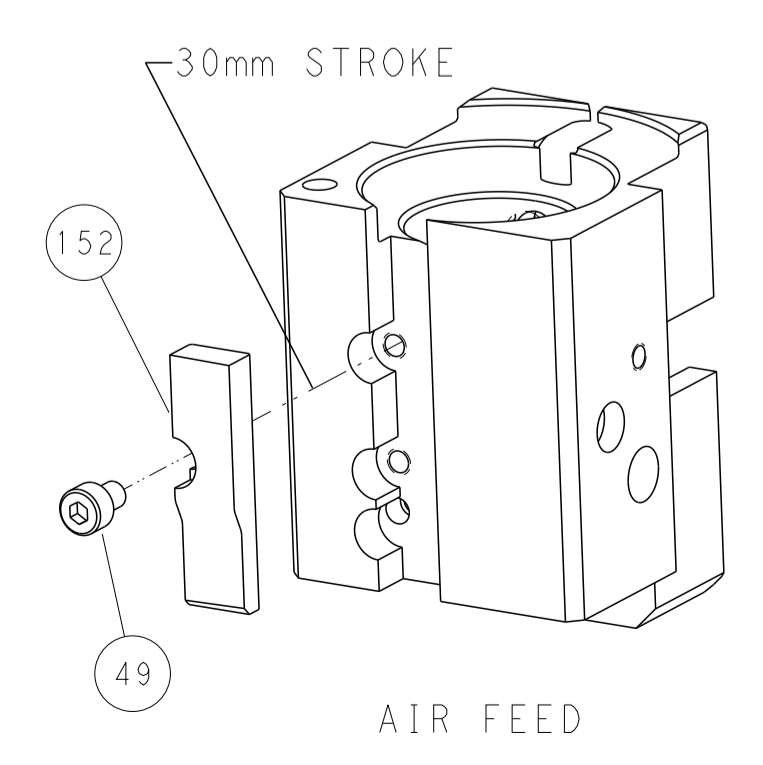

PACIFIC VERSION
 Shown on sheets 3 of 4 & 4 of 4
 (Atlantic version shown on sheets 1 of 4 & 2 of 4)

<small>THIS DRAWING IS UNPUBLISHED. RELEASED FOR PUBLICATION. ALL RIGHTS RESERVED. © 2000 BY TYCO ELECTRONICS CORPORATION. THIS DRAWING IS THE PROPERTY OF TYCO ELECTRONICS CORPORATION AND IS NOT TO BE REPRODUCED OR TRANSMITTED IN ANY FORM OR BY ANY MEANS, ELECTRONIC OR MECHANICAL, INCLUDING PHOTOCOPYING, RECORDING, OR BY ANY INFORMATION STORAGE AND RETRIEVAL SYSTEM, WITHOUT THE WRITTEN PERMISSION OF TYCO ELECTRONICS CORPORATION.</small>		DWN Y.YIN 01FEB2012 CHK G.BAILEY 01FEB2012 S.XI 01FEB2012 APVD S.XI 01FEB2012	TE Connectivity Harrisburg, PA 17105-3608
DIMENSIONS: mm TOLERANCES UNLESS OTHERWISE SPECIFIED: 0 PLC ± 1 PLC ± 2 PLC ± 3 PLC ± 4 PLC ± ANGLES ± FINISH		NAME PRODUCT SPEC APPLICATION SPEC WEIGHT SCALE 1:1	SIZE CAGE CODE DRAWING NO RESTRICTED TO
MATERIAL:		A1 00779 ©=2150005 Customer Accessible Production Drawing	SHEET 4 OF 4 REV G