

DO NOT SCALE FROM THIS PRINT

- NOTES:
1. $\text{\textcircled{C}}$ REPRESENTS A CRITICAL DIMENSION.
 2. BURR ALLOWANCE: .003[0.08] MAX.
 3. PARTS TO BE MOLDED TO POSITION.
 4. MINIMUM PULLOUT FORCE: 5 lbs [22.24 N].
 5. CONTACT MUST BE INSERTED UNTIL RETENTION FEATURE LOCKS INTO PLACE.
 6. ALL FINISHED GOODS ARE TO BE ELECTRICAL TESTED INCLUDING HI-POT TEST @ 1000 VOLTS DC. AFTER FINAL ELECTRICAL TEST, LABEL EACH ASSEMBLY WITH 1 ET STAMP ON THE BODY.
 7. TINNED COPPER WIRE IS ROHS COMPLIANT.
 8. FOLLOW CO-RF-WI-3001-M AND SAMTEC PACKAGING STANDARDS.
 9. CONTACTS OFFSET FOR POLARIZATION.
 10. REFER TO CRIMP SPECIFICATIONS PRINT FOR CRIMP AND STRIP DIMENSIONS, TOLERANCES, TOOLING AND ITS REQUIREMENTS.
 11. FOR LENGTHS LESS THAN 12 IN, TOLERANCE SHALL BE $\pm .125$ [3.18]. FOR OTHER LENGTHS, TOLERANCES SHALL BE $\pm 2\%$.
 12. GOLD PLATING IS NOT REQUIRED ON THE OUTSIDE OF THE CONTACT BOX OR ON THE SIDE WITH THE RETENTION LANCE.
 13. ASSEMBLIES USING THE FEP OPTION ARE FOR CRIMP APPLICATIONS ONLY.
 14. CUT LENGTH IS ASSEMBLY LENGTH MINUS OVERALL LENGTH SUBTRACTOR.

MMSSX-XX-XXX-X-XX.XX-X-X-XXX

FEP CABLE OPTION
 -T: FEP INSULATION (LEAVE BLANK FOR STANDARD PVC INSULATION) (SEE NOTE 13)

No OF POSITIONS
 -02 THRU -25

WIRE GAUGE (AWG)
 PVC:-20, -22, -24, -26, -28, -30
 FEP:-20, -24, -28, 30

COLOR CODE
 C (SEE TABLE 2) (LEAVE BLANK FOR STANDARD BLACK CABLE) (NOT AVAILABLE WITH FEP OPTION)

PLATING SPECIFICATION
 -F: FLASH SELECTIVE (USE C-179-XX-F)
 -L: LIGHT SELECTIVE (USE C-179-XX-L)
 -S: SELECTIVE (USE C-179-XX-S)

OPTION
SINGLE
 -M: METAL LATCH (USE IPD1-XX-S-X-M) (LEAVE BLANK FOR PLASTIC)

DOUBLE
 [MUST BE USED ON -D END OPTION ONLY & APPLIES TO END 2 HOUSING]
 -LUS: PLASTIC LATCH UP, STRAIGHT
 -LDS: PLASTIC LATCH DOWN, STRAIGHT
 -MUS: METAL LATCH UP, STRAIGHT
 -MDS: METAL LATCH DOWN, STRAIGHT

OPTION
 -K: KEYED POLARIZATION (USE IPD1-XX-S-K) (SEE FIG 3, SHEET 2) (LEAVE BLANK FOR NO POLARIZATION; AVAILABLE TO EXISTING CUSTOMERS ONLY)

END OPTION
 -S: SINGLE END
 -D: DOUBLE END (MUST CHOOSE XUS OR XDS OPTIONS.)

ASSEMBLED LENGTH
 SPECIFY IN INCHES [USE DWCX-XX-XX]
 (SINGLE END: 03.00[76.2] INCH MINIMUM, DOUBLE END: 03.25[82.6] INCH MINIMUM)

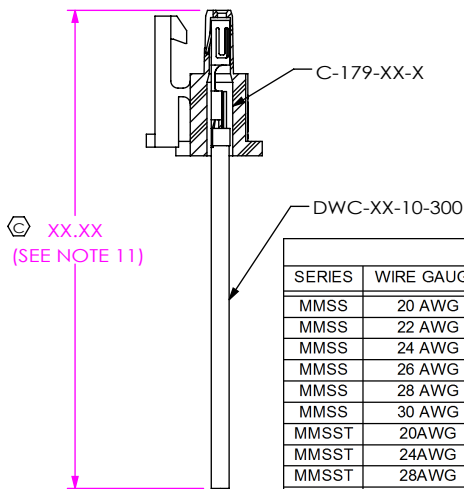
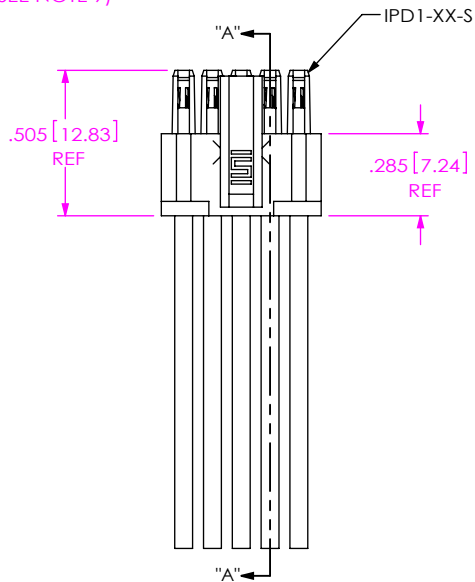
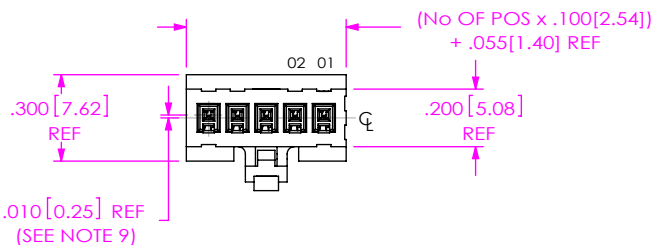

FIG 1
 MMSS-05-22-X-XX.XX-S SHOWN

SECTION "A"- "A"

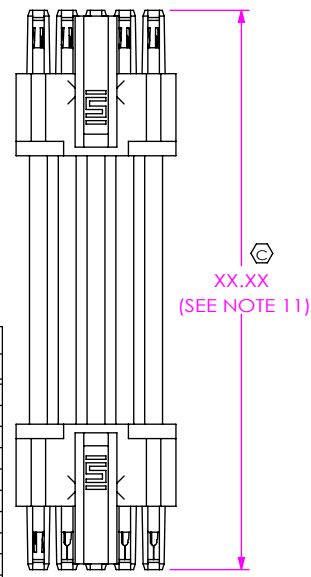

FIG 2
 MMSS-05-22-X-XX.XX-D-LUS SHOWN

TABLE 1				
SERIES	WIRE GAUGE	CABLE	CONTACT	"A"
MMSS	20 AWG	DWC-20-XX-300	C-179-03-X	.128 [3.25]
MMSS	22 AWG	DWC-22-XX-300	C-179-03-X	.128 [3.25]
MMSS	24 AWG	DWC-24-XX-300	C-179-03-X	.128 [3.25]
MMSS	26 AWG	DWC-26-XX-300	C-179-02-X	.133 [3.38]
MMSS	28 AWG	DWC-28-XX-300	C-179-02-X	.133 [3.38]
MMSS	30 AWG	DWC-30-XX-300	C-179-02-X	.133 [3.38]
MMSST	20AWG	DWCT-20-XX-TC	C-179-03-X	.128 [3.25]
MMSST	24AWG	DWCT-24-XX-TC	C-179-03-X	.128 [3.25]
MMSST	28AWG	DWCT-28-XX-TC	C-179-04-X	.128 [3.25]
MMSST	30AWG	DWCT-30-XX-TC	C-179-04-X	.128 [3.25]

UNLESS OTHERWISE SPECIFIED, DIMENSIONS ARE IN INCHES.
 TOLERANCES ARE:
 DECIMALS ANGLES
 .XX: $\pm .01$ [0.3] 2°
 .XXX: $\pm .005$ [0.13]
 .XXXX: $\pm .0020$ [0.051]

PROPRIETARY NOTE
 THIS DOCUMENT CONTAINS CONFIDENTIAL AND PROPRIETARY INFORMATION AND ALL DESIGN, MANUFACTURING, REPRODUCTION, USE, PATENT RIGHTS AND SALES RIGHTS ARE EXPRESSLY RESERVED BY SAMTEC, INC. THIS DOCUMENT SHALL NOT BE DISCLOSED, IN WHOLE OR PART, TO ANY UNAUTHORIZED PERSON OR ENTITY NOR REPRODUCED, TRANSFERRED OR INCORPORATED IN ANY OTHER PROJECT IN ANY MANNER WITHOUT THE EXPRESS WRITTEN CONSENT OF SAMTEC, INC.

MATERIAL: DO NOT SCALE DRAWING SHEET SCALE: 1.5:1
 HOUSING: NYLON 6/6, COLOR: WHITE
 CONTACT: PHOS BRONZE
 CABLE; INSULATION: SEE CALLOUT
 WIRE: TINNED COPPER

samtec
 520 PARK EAST BLVD, NEW ALBANY, IN 47150
 PHONE: 812-944-6733 FAX: 812-948-5047
 e-Mail info@SAMTEC.com code 55322

DESCRIPTION:
 .100[2.54] SOCKET DISCREET CABLE ASSEMBLY

DWG. NO.
MMSSX-XX-XXX-X-XX.XX-X-X-XXX

BY: DEAN P 05/03/2005 SHEET 1 OF 3

TABLE 2 MMSS COLOR CODED WIRE SEQUENCE COLOR										
	BROWN	RED	ORANGE	YELLOW	GREEN	BLUE	VIOLET	GRAY	WHITE	BLACK
DWC-XX-01-300	DWC-XX-02-300	DWC-XX-03-300	DWC-XX-04-300	DWC-XX-05-300	DWC-XX-06-300	DWC-XX-07-300	DWC-XX-08-300	DWC-XX-09-300	DWC-XX-10-300	
PIN #	1	2	3	4	5	6	7	8	9	10
	11	12	13	14	15	16	17	18	19	20
	21	22	23	24	25					

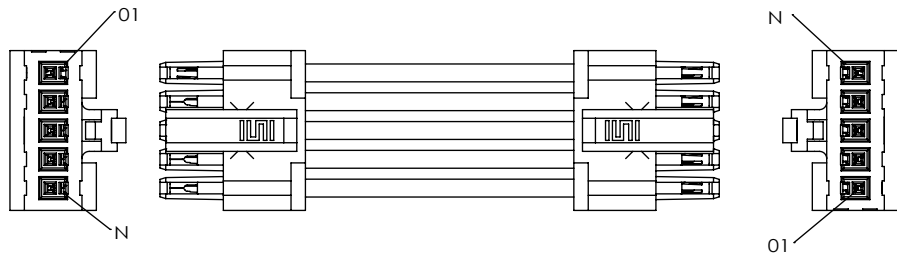

-LUS
[LATCH UP- CABLE STRAIGHT]

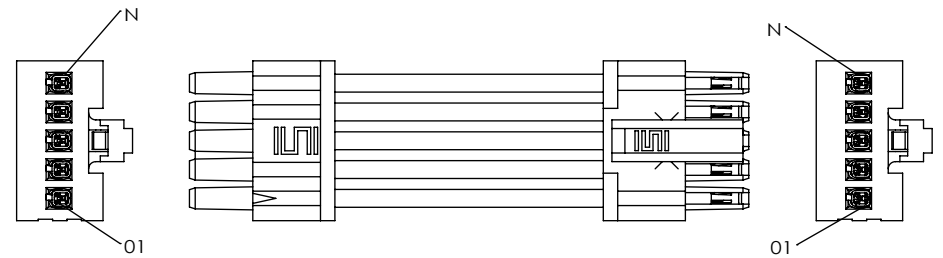

-LDS
[LATCH DOWN- CABLE STRAIGHT]

FIG 3

-K: KEYED POLARIZATION
(MMSSX-06-XX-X-XX.XX-X-K-XXX SHOWN)
(SAME AS FIG 1, UNLESS OTHERWISE STATED)

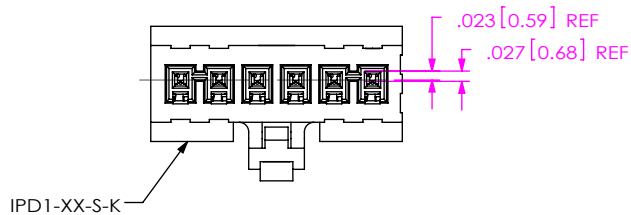

PROPRIETARY NOTE

THIS DOCUMENT CONTAINS CONFIDENTIAL AND PROPRIETARY INFORMATION AND ALL DESIGN, MANUFACTURING, REPRODUCTION, USE, PATENT RIGHTS AND SALES RIGHTS ARE EXPRESSLY RESERVED BY SAMTEC, INC. THIS DOCUMENT SHALL NOT BE DISCLOSED, IN WHOLE OR PART, TO ANY UNAUTHORIZED PERSON OR ENTITY NOR REPRODUCED, TRANSFERRED OR INCORPORATED IN ANY OTHER PROJECT IN ANY MANNER WITHOUT THE EXPRESS WRITTEN CONSENT OF SAMTEC, INC.



520 PARK EAST BLVD, NEW ALBANY, IN 47150
PHONE: 812-944-6733 FAX: 812-948-5047
e-Mail info@SAMTEC.com code 55322

DO NOT SCALE DRAWING

SHEET SCALE: 1.5:1

DESCRIPTION:
.100[2.54] SOCKET DISCREET CABLE ASSEMBLY

DWG. NO.
MMSSX-XX-XXX-X-XX.XX-X-X-XXX

BY: DEAN P 05/03/2005 SHEET 2 OF 3

FIG 4

(MMSSX-06-XX-X-XX.XX-S-M SHOWN)
(SAME AS FIG 1, UNLESS OTHERWISE STATED)

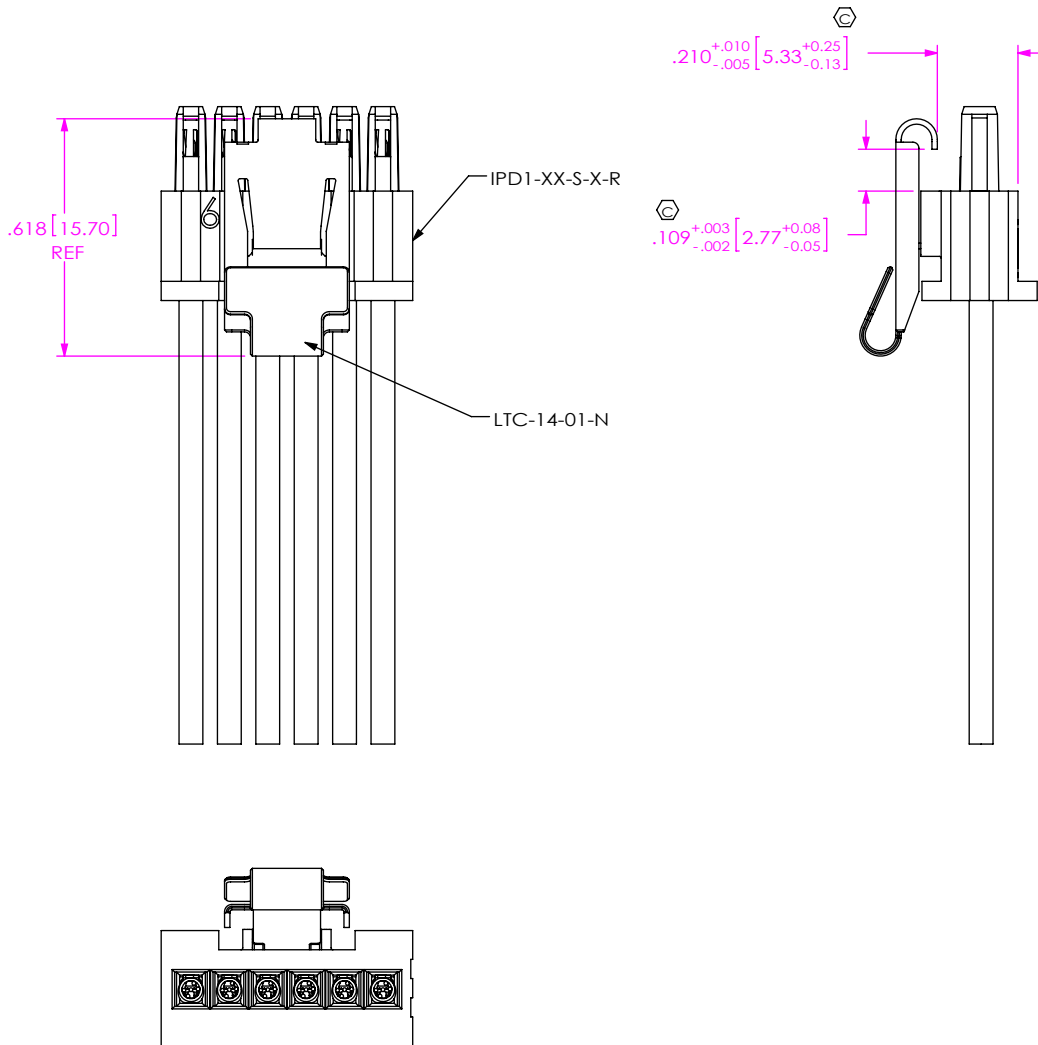

CABLE CUT IN-PROCESS

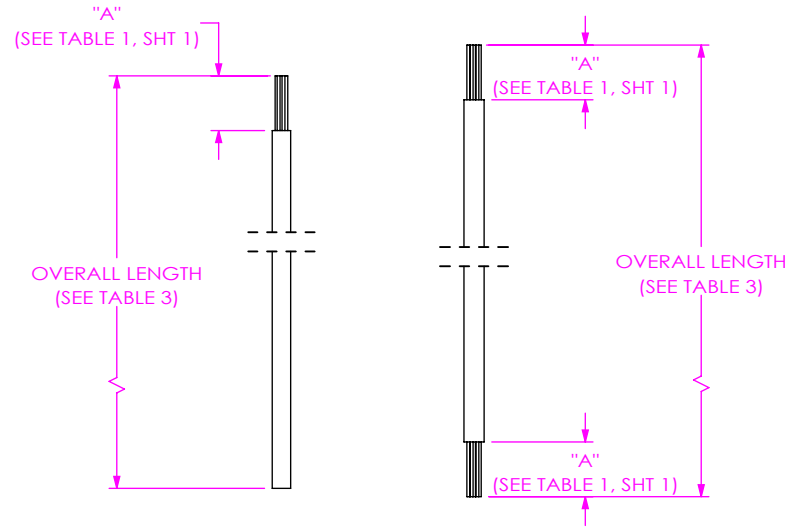

-S: SINGLE END -D: DOUBLE END

TABLE 3 (OVERALL LENGTH SUBTRACTORS) (SEE NOTE 14)	
	LENGTH
-S: SINGLE END	.250 [6.35]
-D: DOUBLE END	.500 [12.70]

PROPRIETARY NOTE

THIS DOCUMENT CONTAINS CONFIDENTIAL AND PROPRIETARY INFORMATION AND ALL DESIGN, MANUFACTURING, REPRODUCTION, USE, PATENT RIGHTS AND SALES RIGHTS ARE EXPRESSLY RESERVED BY SAMTEC, INC. THIS DOCUMENT SHALL NOT BE DISCLOSED, IN WHOLE OR PART, TO ANY UNAUTHORIZED PERSON OR ENTITY NOR REPRODUCED, TRANSFERRED OR INCORPORATED IN ANY OTHER PROJECT IN ANY MANNER WITHOUT THE EXPRESS WRITTEN CONSENT OF SAMTEC, INC.



520 PARK EAST BLVD, NEW ALBANY, IN 47150
PHONE: 812-944-6733 FAX: 812-948-5047
e-Mail info@SAMTEC.com code 55322

DO NOT SCALE DRAWING

SHEET SCALE: 1:1

DESCRIPTION:
.100[2.54] SOCKET DISCREET CABLE ASSEMBLY

DWG. NO.

MMSSX-XX-XXX-X-XX.XX-X-X-XXX

BY: DEAN P 05/03/2005 SHEET 3 OF 3