

THIS DRAWING IS UNPUBLISHED. RELEASED FOR PUBLICATION .19
 © COPYRIGHT 19 BY AMP INCORPORATED. ALL RIGHTS RESERVED.

LOC	DIST	REVISIONS					
AF	50	P	LTR	DESCRIPTION	DATE	DWN	APVD
		V		REL PER 0G3A-0189-03	27MAR03	JR	DD

- ① CIRCUIT IDENTIFICATION.
- ② FOREIGN PRODUCTION ONLY.
- ③ PREPRODUCTION - FASR REQ

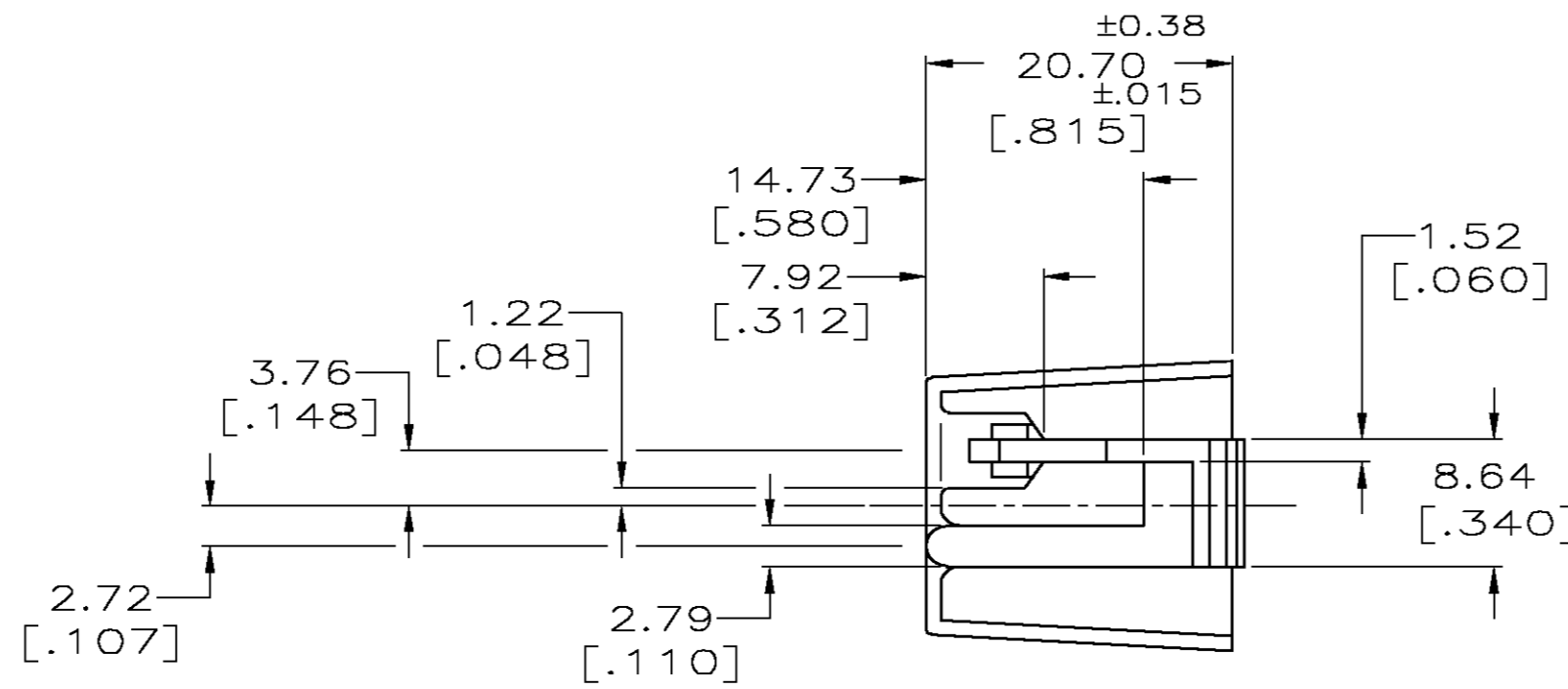
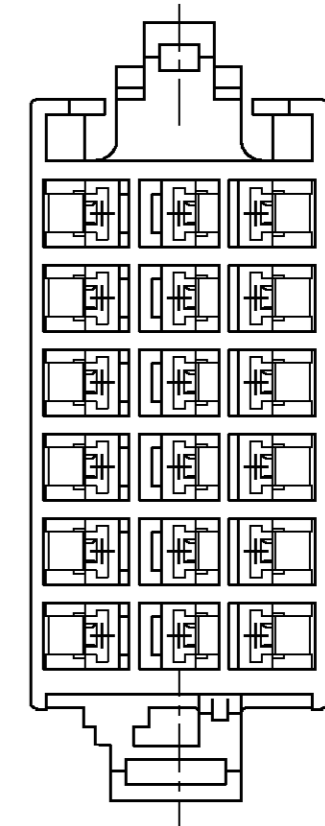
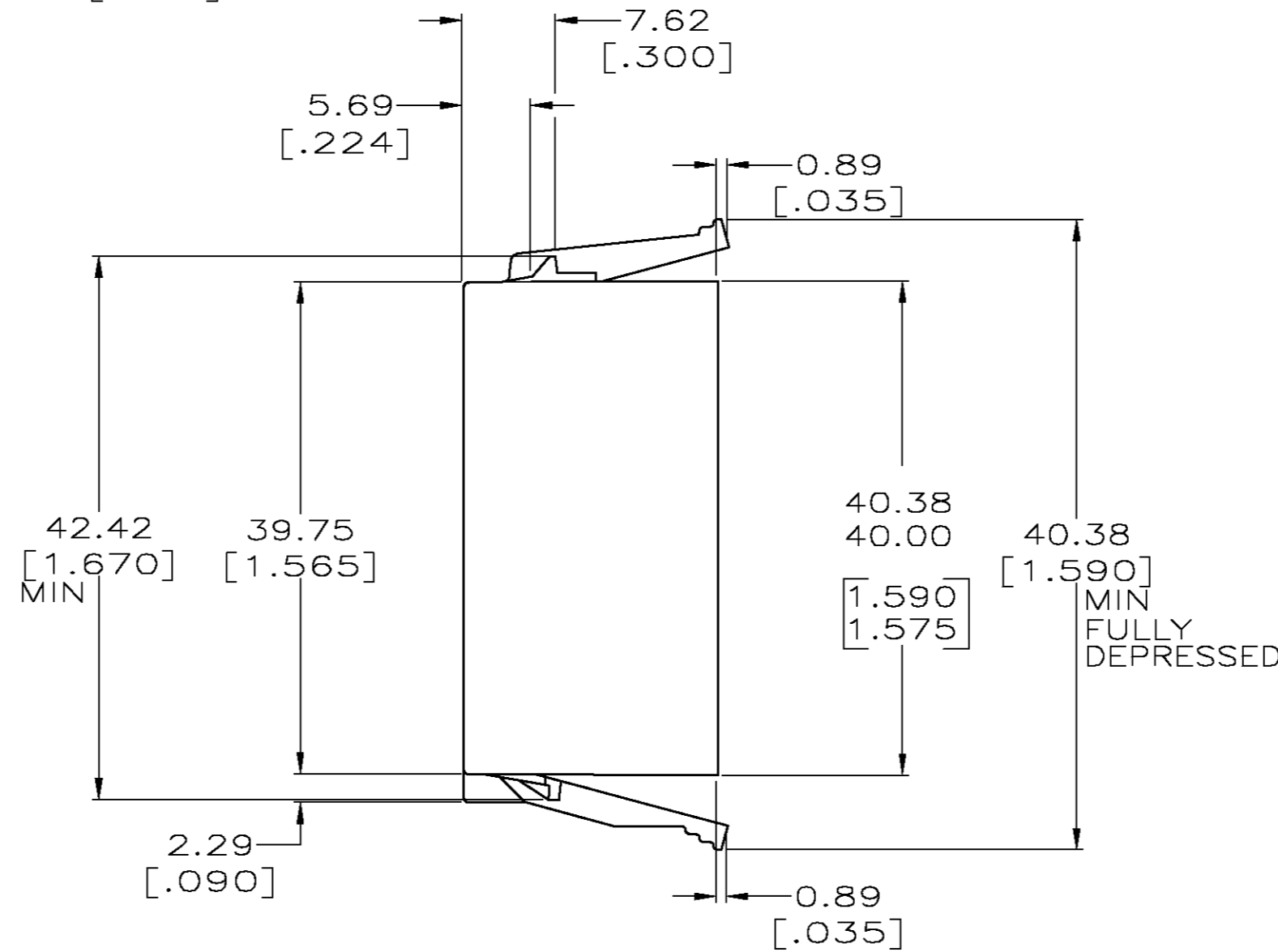
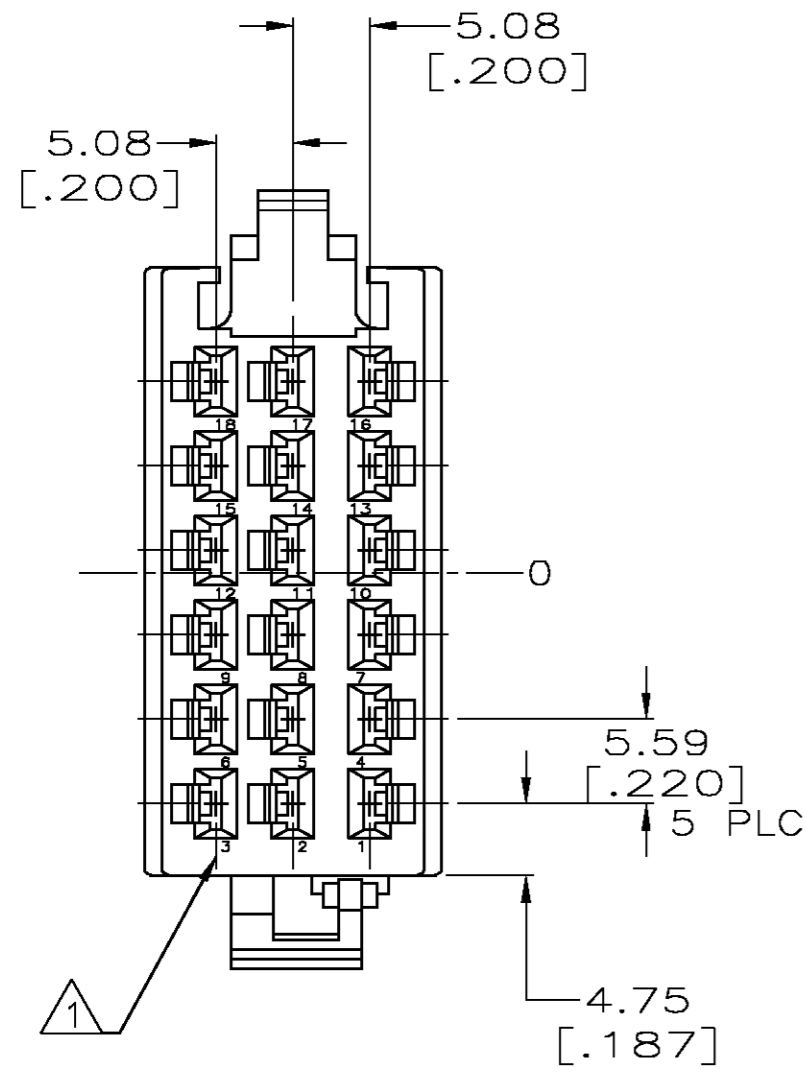
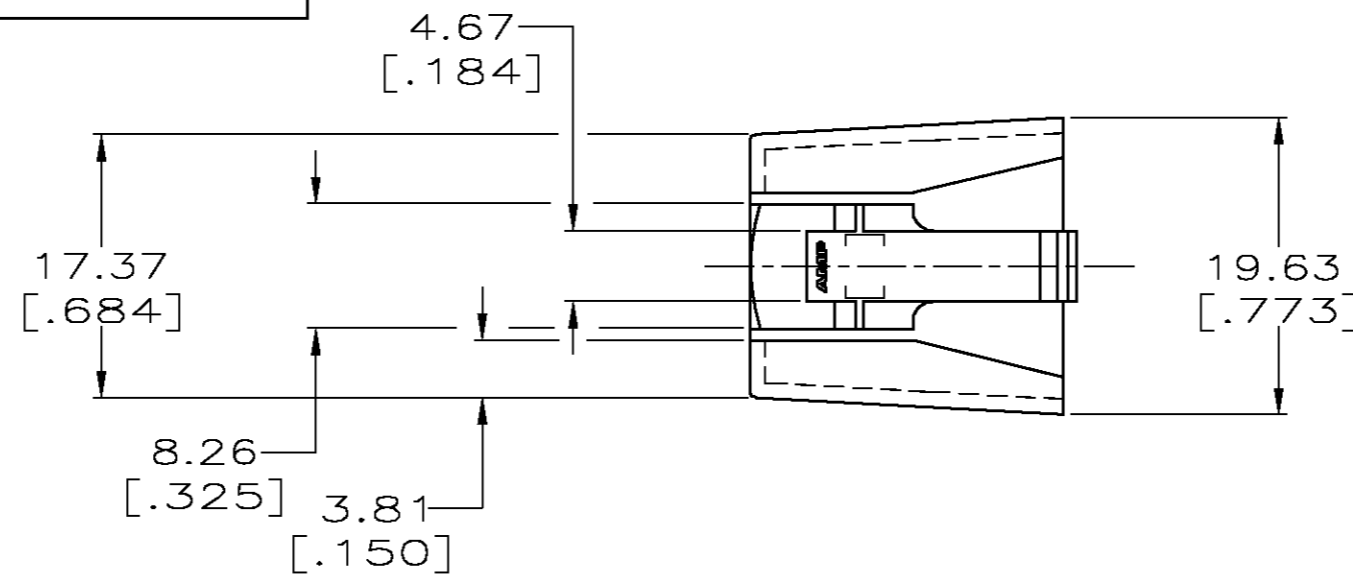

BLACK	NYLON 6/66, UL 94V-0	③ 770199-4
NATURAL	NYLON 6/6	② 770199-3
NATURAL	NYLON 6/6, UL94 V-0	② 770199-2
BLACK	NYLON 6/6	770199-1
FINISH	MATERIAL	PART NUMBER

THIS DRAWING IS A CONTROLLED DOCUMENT.

DWN	M.S. FEHER	10NOV2000
CHK	J.R. RUTH	10NOV2000
APVD	DON DECKER	10NOV2000
NAME	NAME	
PRODUCT SPEC	-	
APPLICATION SPEC	-	
WEIGHT	-	
CUSTOMER DRAWING	SCALE 2:1 SHEET 1 OF 1 REV V	

AMP AMP Incorporated
Harrisburg, PA 17105-3608

HOUSING, RIGHT HAND,
18 CIRCUIT, TIMER CONNECTOR

SIZE A2 CAGE CODE 00779 DRAWING NO. C=770199