

- NOTES:
- PRECEDING ENG. NO. IN CHART DESIGNATES STANDARD PRODUCT.
 - SOLDERABILITY: WHEN PARTS ARE SOLDERED AT A TEMPERATURE OF 230°C (446°F) FOR 5 SECONDS, EACH SOLDERED SURFACE SHALL BE A MINIMUM OF 95% COVERED WITH A SMOOTH CONTINUOUS ADHERENT COATING. FOR OTHER INFORMATION SEE ES-152.
 - PIN PUSH OUT FORCE: PRIOR TO SOLDERING, A 3 POUND MINIMUM FORCE (IN EITHER DIRECTION) SHALL BE REQUIRED TO PUSH THE PIN OUT OF THE HEADER.
 - FOR ADDITIONAL INFORMATION AND TESTING PROCEDURES SEE PS-08-50.
 - PARTS ARE STACKABLE END TO END ON (3.96)/.156 CENTERS.
 - FOR PART WITH PEGS SEE DWG NO. SDA-42492
 - BURRS DUE TO CUTTING OFF OF PINS MUST NOT VARY FROM CENTERLINE OF PIN AT DATUM -D- BY MORE THAN .008 IN ANY DIRECTION.

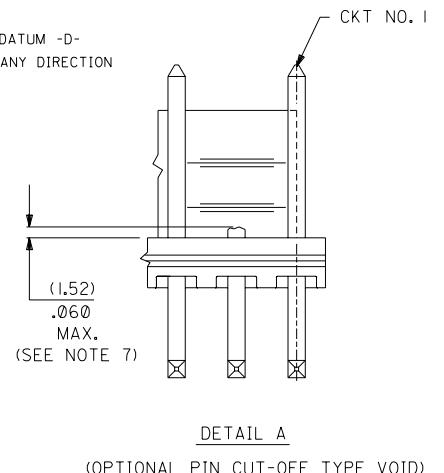

| NO. OF CKT'S. | DIM. A | DIM. B |
|---------------|------------------------|---------------|
| 2 | (3.96±.05) .156±.002 | (7.77) .306 |
| 3 | (7.92±.08) .312±.003 | (11.73) .462 |
| 4 | (11.89±.08) .468±.003 | (15.70) .618 |
| 5 | (15.85±.10) .624±.004 | (19.66) .774 |
| 6 | (19.81±.10) .780±.004 | (23.62) .930 |
| 7 | (23.77±.10) .936±.004 | (27.58) 1.086 |
| 8 | (27.74±.13) 1.092±.005 | (31.55) 1.242 |
| 9 | (31.70±.13) 1.248±.005 | (35.51) 1.398 |
| 10 | (35.66±.13) 1.404±.005 | (39.47) 1.554 |
| 11 | (39.62±.15) 1.560±.006 | (43.43) 1.710 |
| 12 | (43.59±.15) 1.716±.006 | (47.40) 1.866 |
| 13 | (47.55±.15) 1.872±.006 | (51.36) 2.022 |
| 14 | (51.51±.18) 2.028±.007 | (55.32) 2.178 |
| 15 | (55.47±.18) 2.184±.007 | (59.28) 2.334 |
| 16 | (59.44±.18) 2.340±.007 | (63.25) 2.490 |
| 17 | (63.40±.20) 2.496±.008 | (67.21) 2.646 |
| 18 | (67.36±.20) 2.652±.008 | (71.17) 2.802 |

MATERIAL: HEADER: GLASS FILLED POLYESTER, 94V-0, MOLDED NATURAL (WHITE).
PIN: BRASS

PLATINGS:
(102) ELECTRO TIN .000450/.000200 OVER .000200/.000100 COPPER
(567) SELECT GOLD 15 M.I. MIN, SELECT TIN/LEAD 100 M.I. MIN., OVER NICKEL
(569) SELECT GOLD 30 M.I. MIN, SELECT TIN/LEAD 100 M.I. MIN., OVER NICKEL
FOR ADDITIONAL INFORMATION SE SDES-88.

| | | | |
|---|--|--|---|
| REL SHT 5 UCP2003-0755 11/6/2002 SAMIEC | E2 | DIMENSIONS SHOWN (METRIC) INCH UNLESS OTHERWISE SPECIFIED TOLERANCES: ANGULAR ± 1/2° | ▽ = 0 ▽ = 0 REVISE ONLY ON CAD SYSTEM |
| REL SHT 4 UCR2002-0555 12/17/01 SAMIEC | E1 | 3 PLACE ± 2 PLACE ± 1 PLACE ± | TITLE FRICTION LOCK HEADER ASS'Y .156 Q BENT SQ PINS, W/O PEGS 41792 SERIES DWG. |
| ADD PACK SPEC UCR2002-0087 7/26/01 SAMIEC | E | DRAFT WHERE APPLICABLE MUST REMAIN WITHIN DIMENSIONS | MOLEX INCORPORATED LITSE, ILL. 60532 U.S.A. |
| DRWG. BY SAMIEC APP'D. BY LENZ | CHK'D. BY PATEL SCALE : | DRWG. NO. SDA-41792 | SHEET NO. 1 OF 6 DATE 09/09/87 |
| FILE NAME S41792X1 | THIS DRAWING CONTAINS INFORMATION THAT IS PROPRIETARY TO MOLEX INC. AND SHOULD NOT BE USED WITHOUT WRITTEN PERMISSION. | DRWG. NO. SDA-41792 | DIV. KK SIZE C |
| LTR. REVISIONS | LTR. REVISIONS | | |

| | |
|---|----|
| 6 | E |
| 5 | E2 |
| 4 | E1 |
| 3 | E |
| 2 | E |
| 1 | E2 |

