

DESCRIPTION

Demonstration circuit DC1104A is a single-battery charge controller with featuring the LTC4009-2. The input voltage is 13.5 to 20V. The charger output voltage is programmed by jumpers to support 1, 2, 3 and 4-Cell Li-ion batteries with a cell voltage of 4.2V/Cell. The maximum charge current is 2A. The demo board is initially configured for 12.6V Li-ion batteries. The board will automatically charge a battery as soon as input power is applied with a battery connected prior to power up. Status LEDs are provided for CHG, ACP, C/10, and ICL although this charger is not a smart battery charger, a popular smart battery connector is provided that can be used for data-logging with the

OPTIONAL DC1223A-B Demoboard and software. To be clear, you DO NOT need a smart battery to use this board. The optional DC1223A-B SMBus-to-USB port adapter and associated software is to monitor a smart battery for demonstration purposes only. Contact your LT representative for ordering a DC1223A-B.

This Demoboard is capable of supporting the LTC4009 and LTC4009-1 with a simple IC swap-out. See schematic.

Design files for this circuit board are available. Call the LTC factory.

Table 1. Performance Summary

PARAMETER	CONDITIONS / NOTES	VALUE
Maximum Input Voltage	Limited by Input Capacitor Volt Ratings.	20V +/- 10 %
Default Battery Charge Voltage	Jumper Selectable: 4.2V, 8.4V, 12.6V & 16.8V	12.6V
Minimum Input Voltage	$V_{in} > V_{bat}$ Float voltage & $DCDIV > 1.2V$.	13.5V when using a 12.6V Li-ion battery. Recommend 15V.
Shutdown Configuration	$V_{in} > V_{batmax} > 6V$, Jumper Selectable: OFF, THM & ON	ON
Input Current Limit	Set by value of R2 at 100mV.	2 Amps using a 0.05 Ohm resistor.
Maximum Charge Current	$V_{in} > V_{bat} > 6V$ & $DCDIV > 1.2V$	2A +/- 5%

QUICK START PROCEDURE

QUICK START GUIDE FOR DEMONSTRATION CIRCUIT DC1104A

MULTI CELL LI-ION BATTERY CHARGER BOARD

1. Connect the input power source to VIN terminals J1 or VIN and GND using a power supply capable of handling 2.5A of current within a 13.5 to 20V range. The input supply voltage MUST be greater than the full voltage value of the battery to allow a full charge to take place.
2. Connect the load to VOUT and GND terminals.
3. Configure the jumpers for your specific battery.
4. Plug in the battery. Industry-standard 5 Pin AMP Smart Battery connector is provided as well as generic soldering Test Points for hard-wire connections.
5. Turn on the input power supply.
6. Optionally use the provided DC1223A-B demonstration software to configure and communicate with the DC1104A.

OPTIONAL DC1223A-B SMBUS
TO USB ADAPTER

PROVIDES DATA LOGGING AND
BATTERY CONTROL

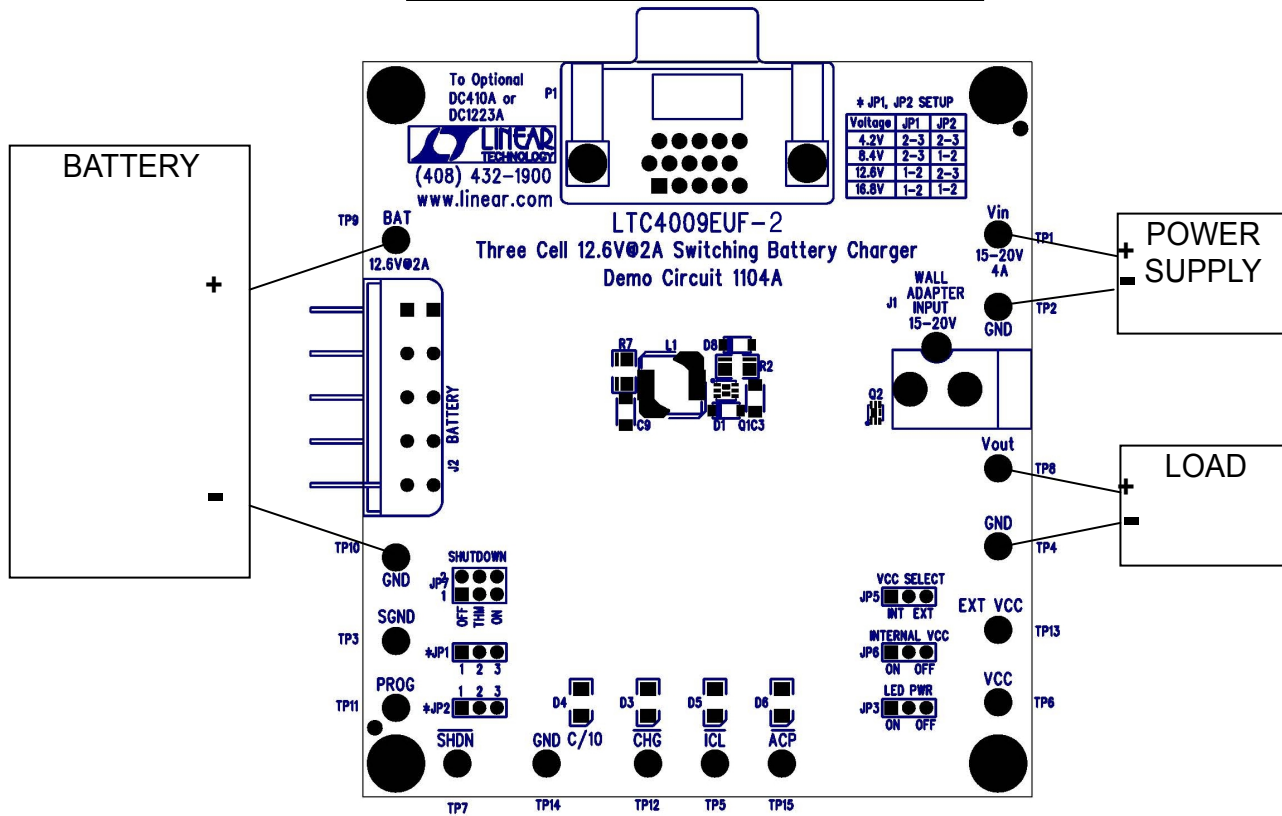

QUICK START GUIDE FOR DEMONSTRATION CIRCUIT DC1104A MULTI CELL LI-ION BATTERY CHARGER BOARD

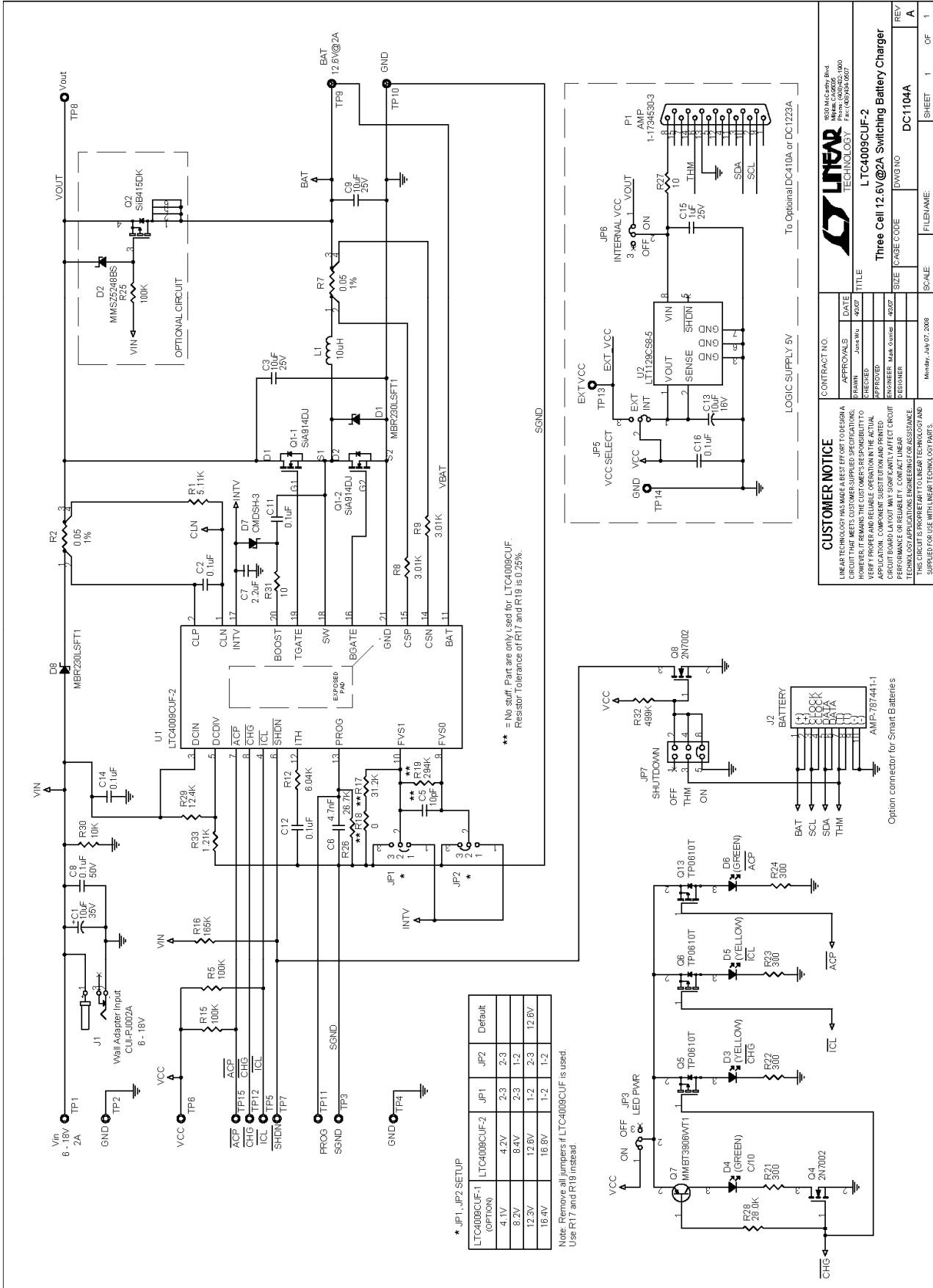

CUSTOMER NOTICE
LINEAR TECHNOLOGY HAS MADE A BEST EFFORT TO DESIGN A CIRCUIT THAT MEETS CUSTOMER SUPPLIED SPECIFICATIONS. HOWEVER, IT REMAINS THE CUSTOMER'S RESPONSIBILITY TO VERIFY PROPER AND RELIABLE OPERATION IN THE ACTUAL APPLICATION. COMPONENT SUBSTITUTION AND PRINTED PERFORMANCE OR RELIABILITY. CONTACT LINEAR TECHNOLOGY APPLICATIONS ENGINEERING FOR ASSISTANCE. THIS CIRCUIT IS PROPRIETARY TO LINEAR TECHNOLOGY AND SUPPLIED FOR USE WITH LINEAR TECHNOLOGY PARTS.

CONTRACT NO. 42007
DATE 4/2007
REVISED BY June Wu
DESIGNED BY Mark Suter
DRAWING NO. DC1104A

LINEAR TECHNOLOGY
8300 M.C. Fry Blvd.
Folsom, CA 95632-1900
Phone: (916) 951-1900
Fax: (916) 951-1907

LTC4009CUF-2
Three Cell 12.8V@2A Switching Battery Charger

APPROVALS: _____
DATE: _____
DESIGNED BY: _____
DRAWING NO: _____
SCALE: _____
SHEET: 1 OF 1

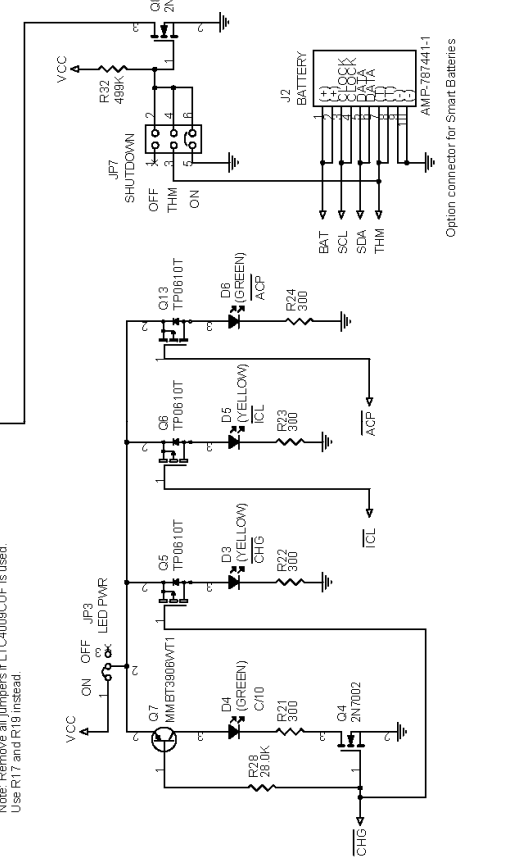
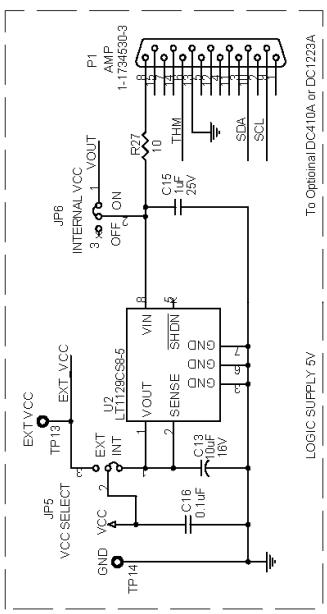

QUICK START GUIDE FOR DEMONSTRATION CIRCUIT DC1104A

MULTI CELL LI-ION BATTERY CHARGER BOARD

Item	Qty	Reference	Part Description	Manufacturer / Part #
REQUIRED CIRCUIT COMPONENTS				
1	1	C1	CAP., Alum. 10uF, 35V, 5X6.0 size	SANYO..35CE10AX
2	5	C2,C8,C11,C14,C16	CAP., X7R, 0.1uF, 50V, 10% 0603	TDK, C1608X7R1H104K
3	1	C12	CAP., X7R, 0.1uF, 16V, 10% 0402	TDK, C1005X7R1C104K
4	2	C3,C9	CAP., X5R, 10uF, 25V, 20% 1206	Taiyo Yuden, TMK316BJ106ML
5	1	C6	CAP., X7R, 4.7nF, 50V, 10% 0402	TDK, C1005X7R1H472K
6	1	C7	CAP., X5R, 2.2uF, 16V, 20% 0805	TDK, C2012X5R1C225M
7	1	C13	CAP., Tant. 10uF 16V 20% 3828	AVX TAJB106M016
8	1	C15	CAP., X7R 1.0uF 25V 10% 1206	AVX 12063C105KAT
9	2	D1,D8	Schottky Rect., MBR230LSFT1 SOD-123FL	On Semi., MBR230LSFT1G
10	2	D3,D5	LED, AMBER	Panasonic, LN1451C-(TR) PBF
11	2	D4,D6	LED, GREEN	Panasonic, LN1351C-(TR) PBF
12	1	D7	DIODE, CMDSH-3, SOD-323	CENTRAL SEMI.,CMDSH-3TR (PBF)
13	1	L1	Inductor, 10uH, CDR7D28MN SERIES	Sumida, CDR7D28MNNP-100 NC
14	1	Q1	Dual-N-CH FET, SiA914DJ, Powerpak SC-70-6	VISHAY, SiA914DJ-T1-E3
15	1	R1	RES., CHIP, 5.11K, 1/16W, 1% 0603	VISHAY, CRCW06035K11FKEA
16	2	R2,R7	SENSE RES., LRC, 0.05, 0.25W, 1% 1206	WISHAY, WSL1206R0500FEA
17	2	R5,R15	RES., CHIP, 100K, 1/16W, 5% 0402 e3	VISHAY, CRCW0402100KJNED
18	2	R8,R9	RES., CHIP, 3.01K, 1/16W, 1% 0402	VISHAY, CRCW04023K01FKED
19	1	R12	RES., CHIP, 6.04K, 1/16W, 1% 0402	VISHAY, CRCW04026K04FKED
20	1	R16	RES., CHIP, 165K, 1/16W, 1% 0402 e3	VISHAY, CRCW0402165KFKED
21	1	R26	RES., CHIP, 26.7K, 1/16W, 1% 0402	VISHAY, CRCW040226K7FKED
22	2	R27,R31	RES., CHIP, 10, 1/16W, 5% 0603	VISHAY, CRCW060310R0JNEA
23	1	R29	RES., CHIP, 12.4K, 1/16W, 1% 0402	VISHAY, CRCW040212K4FKED
24	1	R30	RES., CHIP, 10K, 1/16W, 5% 0603 e3	VISHAY, CRCW060310K0JNEA
25	1	R33	RES., CHIP, 1.21K, 1/16W, 1% 0402 e3	VISHAY, CRCW04021K21FKED
26	1	U1	I.C. LTC4009CUF-2, QFN-20(4X4)	LINEAR TECH., LTC4009CUF-2#PBF
27	1	U2	I.C. LT1129CS8-5 SOS	LINEAR TECH., LT1129CS8-5#PBF

Item	Qty	Reference	Part Description	Manufacturer / Part #
ADDITIONAL DEMO BOARD CIRCUIT COMPONENTS				
1	1	D2	DIODE, MMSZ5248BS, SOD-323	Diodes Inc., MMSZ5248BS-7-F
2	1	Q2	P-CH MOSFET, SiB415DK, Powerpak SC-75-6L	VISHAY, SiB415DK-T1-E3
3	1	R25	RES., CHIP, 100K, 1/16W, 5% 0402 e3	VISHAY, CRCW0402100KJNED
4	0	(U1 Option)	I.C. LTC4009CUF-1, QFN-20(4X4)	LINEAR TECH., LTC4009CUF-1#PBF
5	0	(U1 Option)	I.C. LTC4009CUF, QFN-20(4X4)	LINEAR TECH., LTC4009CUF#PBF
6	0	R17(for 4009CUF only)	RES., CHIP, 31.2K, 1/16W, 025% 0402 e3	
7	0	R18(for 4009CUF only)	RES., CHIP, 0, 0402 e3	
8	0	R19(for 4009CUF only)	RES., CHIP, 294K, 1/16W, 0.25% 0402 e3	
9	0	L1 (Option)	Inductor, 10uH, IHLP-2525CZ-01 SERIES	VISHAY, IHLP2525CZER100M01
10	0	C5(for U1=4009CUF only)	CAP., COG, 10pF, 50V, +/-0.5pF 0402	

QUICK START GUIDE FOR DEMONSTRATION CIRCUIT DC1104A

MULTI CELL LI-ION BATTERY CHARGER BOARD

Item	Qty	Reference	Part Description	Manufacturer / Part #
HARDWARE FOR DEMO BOARD ONLY				
1	15	TP1-TP15	TESTPOINT, TURRET, .061"	MILL-MAX, 2308-2-00-80-00-00-07-0
2	1	J1	Connector	Cui-Stack, CUI-PJ002A(PBF)
3	1	J2	Connector	AMP Inc. 787441-1 (PBF)
4	5	JP1~JP3,JP5,JP6	HEADER 3 PIN 0.079 SINGLE ROW	SAMTEC, TMM103-02-L-S
5	6	JP1~JP3,JP5~JP7	SHUNT, .079" CENTER	SAMTEC, 2SN-BK-G
6	1	JP7	2X3, 0.079 DOUBLE ROW HEADER	SAMTEC, TMM103-02-L-D
7	3	Q6,Q5,Q13	P-Chan., TP0610T SOT-23	VISHAY, TP0610T-E3
8	1	Q7	TRANSISTOR, MMBT3906WT1 SOT-323	On Semi., MMBT3906WT1G
9	2	Q4,Q8	N-CH MOSFET, 2N7002	ZETEX, 2N7002 (PBF)
10	1	R32	RES., CHIP, 499K, 1/16W, 1% 0603 e3	VISHAY, CRCW0603499KFKEA
11	1	R28	RES., CHIP, 28.0K, 1/16W, 1% 0603	VISHAY, CRCW060328K0FKEA
12	4	R21,R22,R23,R24	RES., CHIP, 300, 1/16W, 5% 0603	VISHAY, CRCW0603300RJNEA
13	1	P1	Connector, DSUB, 15 PIN	AMP Inc. 1-1470250-3
14	4	STAND-OFF	STAND-OFF, NYLON 0.25"	KEYSTONE, 8831(SNAP ON)
15	1		FAB, PRINTED CIRCUIT BOARDS	DEMO CIRCUIT #1104A
16	2		STENCIL	STENCIL 1104A