

DO NOT SCALE

DIMENSIONS IN MM.

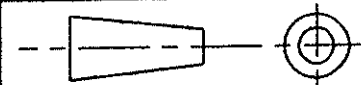

C.A.D. FILE CODE
5. C342063.2

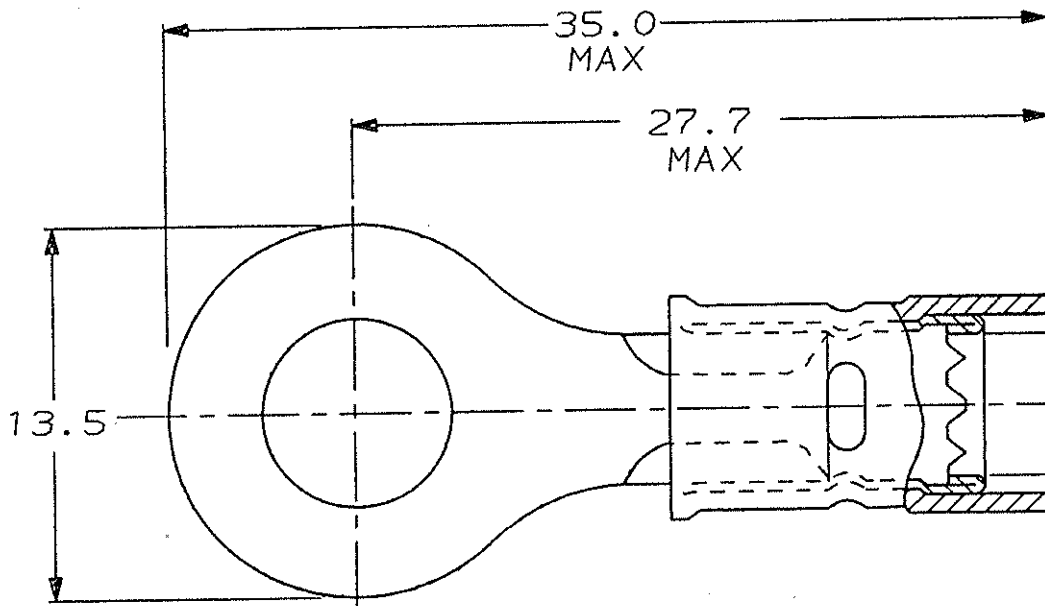

1 WIRE INSUL. DIA 3.81-6.35
2 TONGUE MAT'L THK 1.07 MAX

B

| | | | | | | | | | |
|------------------------------------|-----------|--------------|------------------------------------------------------------|----------------------------------------------------------------------------------------------------------------------------------------------------------------------------------------------------------|-------------------------------------|------|----------|-----|-------|
| CUSTOMER DWG FOR REFERENCE ONLY | | | | THIS INFORMATION IS CONFIDENTIAL AND IS DISCLOSED TO YOU ON CONDITION THAT NO FURTHER DISCLOSURE IS MADE BY YOU TO OTHER THAN AMP PERSONNEL WITHOUT WRITTEN AUTHORIZATION FROM AMP OF GREAT BRITAIN LTD. | | | | | |
| | | | TOLERANCES UNLESS OTHERWISE STATED : | | DR. C. NIKER 17/01/95 | | | | |
| | | | DEC ± 0.5 ANGLES ± 1° | | CH. B. WILSON APP. B. WILSON | | | | |
| | | | NAME | | AMP of Great Britain Ltd. | | | | |
| | | | 16-14 HD PIDG R/T 1/4" STUD NYLON INSULATION BLACK EXP. | | TERMINAL HOUSE STANMORE MIDD. | | | | |
| A | DR/Tm | CG3A-0002 | 3/04 | SCALE | LOC | SIZE | DWG. No. | REV | SHEET |
| 2 | B. WILSON | EB00-0014-95 | 17/01/95 | NTS | E | A 4 | C342063 | A | 1/1 |
| REV | APPROVED | CHANGE No. | DATE | | | | | | |