



# MAX78630+PPM Evaluation Kit User Manual

**July 2013  
Rev. 0**

*Maxim Integrated cannot assume responsibility for use of any circuitry other than circuitry entirely embodied in a Maxim Integrated product. No circuit patent licenses are implied. Maxim Integrated reserves the right to change the circuitry and specifications without notice at any time.*

**Maxim Integrated 160 Rio Robles, San Jose, CA 95134 USA 1-408-601-1000**

© 2013 Maxim Integrated Products, Inc. Maxim Integrated and the Maxim Integrated logo are trademarks of Maxim Integrated Products, Inc.

## Table of Contents

<b>1</b>	<b>Introduction .....</b>	<b>4</b>
1.1	Ordering Information .....	4
1.2	Package Contents.....	4
1.3	System Requirements .....	4
1.4	Safety and ESD Notes .....	6
1.5	Testing the MAX78630+PPM EV Board Prior to Shipping.....	6
<b>2</b>	<b>Installation .....</b>	<b>7</b>
2.1	USB Driver Installation.....	7
2.1.1	Confirm COM Port Mapping.....	7
2.1.2	FTDI COM Port Trouble Shooting.....	7
2.2	Powering the EV Kit Board .....	8
2.3	Basic Connection Setup .....	8
2.3.1	Wye-Connected or 3V Delta-Connected Three-Phase Systems.....	8
2.3.2	2V Delta-Connected Three-Phase Systems .....	10
2.3.3	Neutral Current Measurement Considerations .....	12
2.4	Analog Input Jumper Descriptions.....	13
<b>3</b>	<b>Serial Interfaces Selection and Configuration .....</b>	<b>14</b>
3.1	UART Interface Settings .....	14
3.2	SPI Settings .....	15
<b>4</b>	<b>Graphical User Interface (GUI).....</b>	<b>17</b>
4.1	GUI Initialization.....	17
4.1.1	SSI ID Tab.....	17
4.1.2	Device Tab .....	18
4.1.3	Scaling Tab .....	18
4.1.4	Direct Tab.....	19
4.1.5	Command and Configuration Tab.....	20
4.1.6	Calibration Tab.....	21
4.1.7	Power Tab.....	21
4.1.8	Energy Tab.....	22
4.1.9	Fundamental Tab .....	22
4.1.10	Min/Max Tab .....	23
4.1.11	Alarm Tab .....	24
4.1.12	Monitor Tab.....	25
<b>5</b>	<b>Schematics, Bill of Materials, and PCB Layouts.....</b>	<b>26</b>
5.1	MAX78630+PPM EV Board Schematics .....	26
5.2	MAX78630+PPM EV Board Bill of Materials .....	28
5.3	MAX78630+PPM EV Board PCB Layouts.....	30
<b>6</b>	<b>Contact Information .....</b>	<b>32</b>
	<b>Revision History .....</b>	<b>32</b>

## Figures

Figure 1: MAX78630+PPM EV Kit Typical Application Diagram.....	5
Figure 2: MAX78630+PPM EV Board Connections.....	8
Figure 3: MAX78630+PPM EV Board Connections.....	10
Figure 4: MAX78630+PPM EV Board Connections.....	12
Figure 5: MAX78630+PPM EV Board Electrical Schematic (1 of 2).....	26
Figure 6: MAX78630+PPM EV Board Electrical Schematic (2 of 2).....	27
Figure 7: MAX78630+PPM EV Board PCB Top View .....	30
Figure 8: MAX78630+PPM EV Board PCB Bottom View .....	31

## Table

Table 1: J15 Jumper Description.....	13
Table 2: J11 Jumper Description.....	13
Table 3: J13 Jumper Description.....	13
Table 4: J19 Jumper Description.....	13
Table 5: J42 Jumper Description.....	13
Table 6: J14 Jumper Description.....	13
Table 7: J20 Jumper Description.....	13
Table 8: J43 Jumper Description.....	13
Table 9: SW4 Serial Interface Selection .....	14
Table 10: SW5 Address Selection .....	14
Table 11: Jumper Setting for UART/USB Interface.....	14
Table 12: Jumpers Settings for UART/RS-485/422 .....	15
Table 13: J22 RS-485/422 Connector Pin Assignment .....	15
Table 14: Jumper Setting for SPI/USB Interface.....	15
Table 15: Jumper Settings for Connecting on J16 .....	16
Table 16: J16 Connector Pin Assignment.....	16
Table 17: MAX78630+PPM EV Board Bill of Materials.....	28

## 1 Introduction

The MAX78630+PPM Evaluation Kit (EV kit) demonstrates the capability of the MAX78630+PPM for monitoring a three-phase AC load using up to three voltages and three currents (sensors included). The EV kit connects to a PC through a USB cable that provides both power and data communication to the board. A Windows®-based graphical user interface (GUI) communicates with the device over a virtual for simplified access to measurement data and controls.

### 1.1 Ordering Information

PART	TYPE
MAX78630+PPMEVK1#	EV Kit

#Denotes a RoHS-compliant device that may include lead that is exempt under the RoHS requirements.

### 1.2 Package Contents

The MAX78630+PPM EV kit includes the following:

- MAX78630+PPM EV Board
- Three 50A Current Transformers (CR Magnetics CR-8449-2500-N)
- USB Cable Assembly USB A-B 28/24 1.8M (Tyco/Amp 1487588-3)
- CD with Documentation, GUI Application, and USB Drivers
- Calibration Coefficients Document (Hardcopy Only)

### 1.3 System Requirements

In addition to an AC source and load for measuring, the MAX78630+PPM EV kit requires use of a PC with the following features:

- 1GHz processor and 1GB RAM
- Minimum 1024 x 768 video display resolution
- Available USB port
- Microsoft Windows 7 or Windows XP®

*Windows and Windows XP are registered trademarks of Microsoft Corp.*

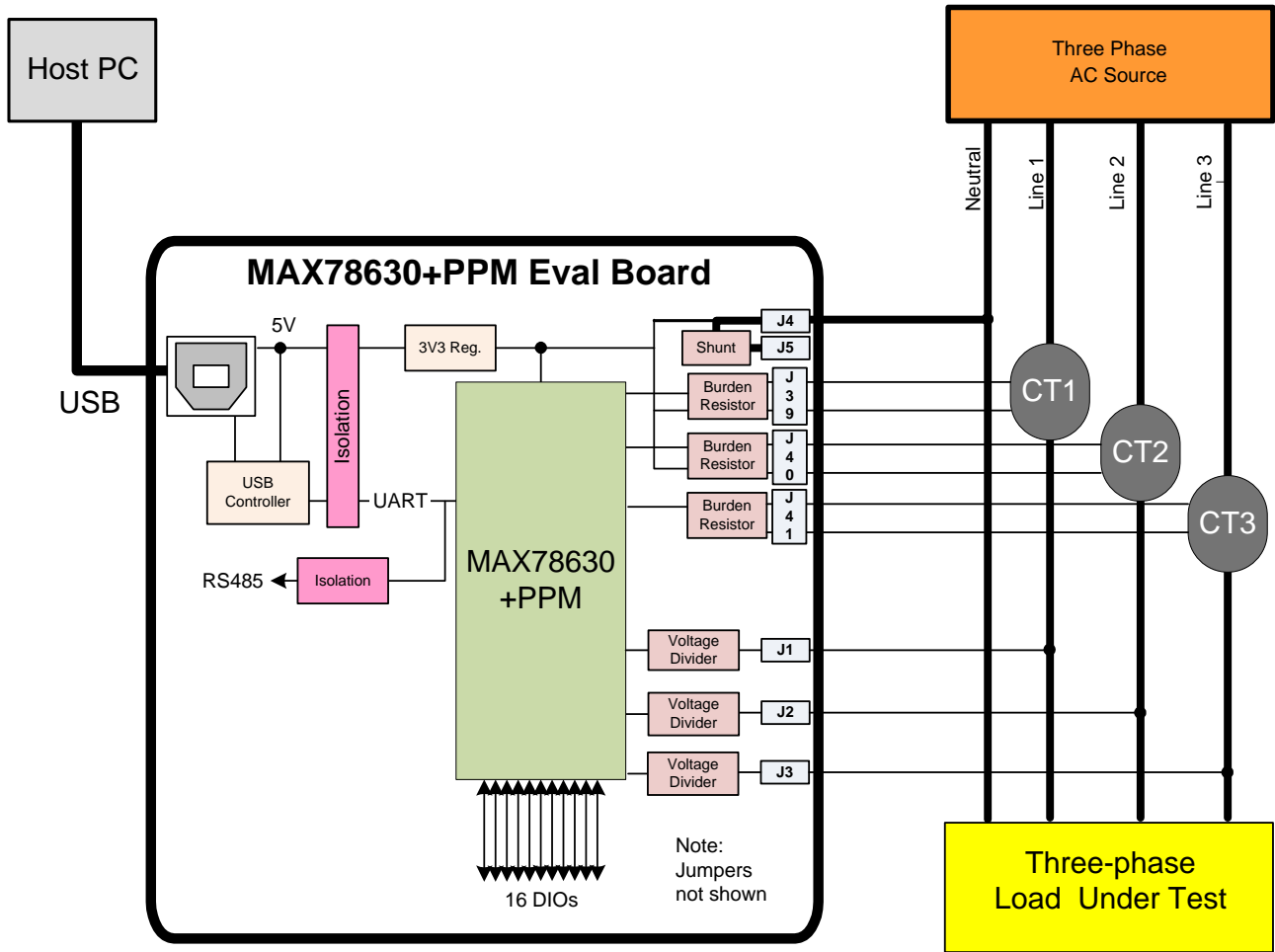

Figure 1: MAX78630+PPM EV Kit Typical Application Diagram

## 1.4 Safety and ESD Notes

### EXERCISE CAUTION WHEN LIVE AC VOLTAGES ARE PRESENT!



Do not connect test equipment, ICE emulators or external development boards directly to the MAX78630+PPM hardware. Damage to the MAX78630+PPM and external equipment will occur due to the MAX78630+PPM's "high side" reference topology. The MAX78630+PPM's V3P3 (i.e., "high side") is connected directly to Neutral (Earth Ground) or Line Voltage, creating a ground reference disparity with any properly grounded external equipment.

The board components and firmware settings are designed to operate with the following nominal AC electrical ranges:

Voltage	Current	Line Frequency
10-400V AC	10mA – 50A	46-64Hz

The maximum current is determined by the current transformer (CT) that is provided with this EV kit: CR Magnetics model no. CR8449-2500-N.

## 1.5 Testing the MAX78630+PPM EV Board Prior to Shipping

Before every EV kit is shipped, the board (and sensors) undergoes a single-load point calibration using precise energy source equipment. The device temperature is also calibrated at the same time. Results printed out on paper and included with the EV kit.

Note that the board is calibrated using the marked CTs included with the kit. Therefore, CT1 should be connected to I1, CT2 to I2, and CT3 to I3.

## 2 Installation

### 2.1 USB Driver Installation

This EV kit includes an isolated USB interface for serial communications with a PC. The FTDI USB controller IC FT2232 performs the USB functions. The FTDI Windows driver presents a virtual COM port for enabling serial communications. The FTDI Windows driver is a certified driver for Windows XP and Windows 7.

Upon attaching the MAX78630+PPM EV board to the PC, the **Found New Hardware Wizard** automatically launches and installs the appropriate driver files. If your PC does not find the FTDI driver files on its local hard disk drive, locate and reference the FTDI USB Driver and Utilities subdirectory on the CD. The FT2232 controller is powered from the USB cable and is active even when no AC power is applied to the MAX78630+PPM EV kit.

**Note:** If an older FTDI driver has been previously installed, it is recommended to remove the older version before installing this newer FTDI driver. Execute the **ftdiClean.exe** utility from the FTDI USB Driver and Utilities subdirectory.

For FTDI driver support on other operating systems, refer to the FTDI website at [www.ftdichip.com](http://www.ftdichip.com).

#### 2.1.1 Confirm COM Port Mapping

- Launch the **Control Panel** and click on the **System** icon.
- The **System Properties** screen appears. Click on the **Hardware** tab. Click on **Device Manager**. Under **Ports (COM & LPT)**, look for the **USB Serial Port** assignment.
- Take note of the COM port assignment for the USB Serial Port.

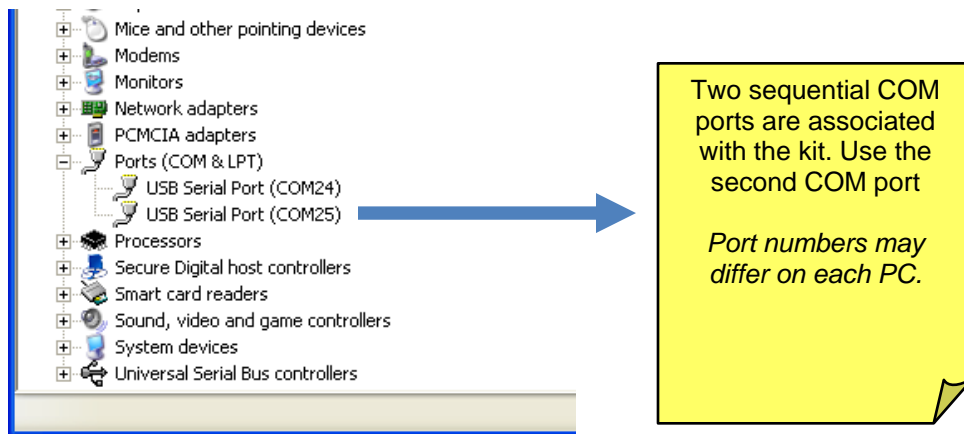

#### 2.1.2 FTDI COM Port Trouble Shooting

If the FTDI device driver did not install properly, there would be no assigned COM port number for the FTDI controller. Repeat the USB Driver Installation, see [Section 2.1](#).

Microsoft Windows may associate a Ball Point device to the FTDI USB controller. When this occurs a FTDI device COM port assignment is available via HyperTerminal but there is no communications data. Verify if a Ball Point device has been added to the "Human Interface Devices" via the Device manager. See [Section 2.1.1](#) for access to the Device Manager. If a Ball Point device exists, delete it and unplug and replug the EV kit's USB cable.

## 2.2 Powering the EV Kit Board

The MAX78630+PPM EV board is normally powered through the USB port (J21). If power needs to be supplied from a different source, a 5V DC can be applied to the connector J16; see [Table 16](#) for the pin assignment.

When the MAX78630+PPM EV board is powered through via USB, the same cable also provides the communications link between the host PC and the MAX78630+PPM EV board.

## 2.3 Basic Connection Setup

This section shows examples of basic connections between the MAX78630+PPM EV board and external equipment. Additional connection examples can be seen in the MAX78630+PPM IC data sheet. Note that this board does not directly support voltage transformers (VT) and provides a shunt resistor as alternative to the current transformer on phase C.

The following examples are only a subset of all possible measurement configurations. Refer to the MAX78630+PPM IC data sheet for configurations and system connection diagrams.

### 2.3.1 Wye-Connected or 3V Delta-Connected Three-Phase Systems

For Wye-connected systems, all three-phase (Line-to-Neutral) voltages are measured. The Neutral line is the reference for all voltages (V3P3A). Jumper J11 must be in position 2-3 (3V Wye/Delta). It is also possible to directly measure all three voltages in a Delta configuration. In that case, the Neutral is not accessible and the MAX78630+PPM EV board is at a virtual center potential.

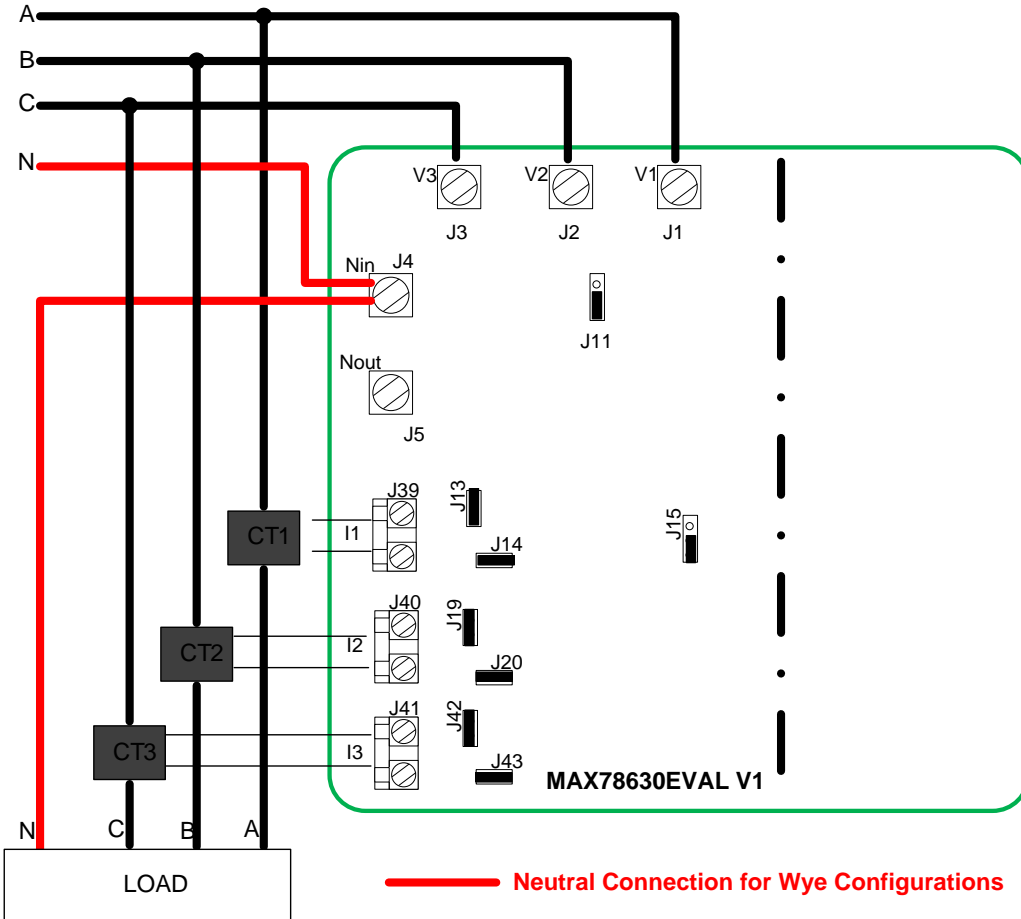

Figure 2: MAX78630+PPM EV Board Connections



1. Set Jumper J11 to position 2-3.
2. Set Jumper J15 to position 1-2.
3. Connect the Neutral from Source to Load and to J4 (Nin) (Wye-connected systems only).
4. Connect the AC source: Phase A to J1, phase B to J2 and Phase C to J3.
5. Connect Phase A current sensor' secondary side to J39.
  - a. If using a CT, enable burden resistor by closing jumper J13. Also close jumper J14 to disable the 2nd RC circuit.
  - b. If using a Rogowski coil, disable burden resistor by opening jumper J13. Also open jumper J14 to enable the 2nd RC circuit.
6. Connect Phase B current sensor' secondary side to J40.
  - a. If using a CT, enable burden resistor by closing jumper J19. Also close jumper J20 to disable the 2nd RC circuit.
  - b. If using a Rogowski coil, disable burden resistor by opening jumper J19. Also open jumper J14 to enable the 2nd RC circuit.
7. Connect Phase C current sensor' secondary side to J41.
  - a. If using a CT, enable burden resistor by closing jumper J42. Also close jumper J43 to disable the 2nd RC circuit
  - b. If using a Rogowski coil, disable burden resistor by opening jumper J42. Also open jumper J14 to enable the 2nd RC circuit
8. Always refer to the IC data sheet for proper connections according to the desired configuration.
9. Write the corresponding value of the CONFIG register to the MAX78630+PPM according to the configuration and the choice of sensors.

**Note:** If a phase is backwards, reverse the current flow through the respective current sensor.

### 2.3.2 2V Delta-Connected Three-Phase Systems

For Delta-connected systems, it is possible to measure only two line (Line-to-Line) voltages. For this board, Phase B can be used as reference (V3P3A), therefore measuring  $V_{AB}$  and  $V_{CB}$ . Jumper J11 must be in position 1-2 (2V Delta).

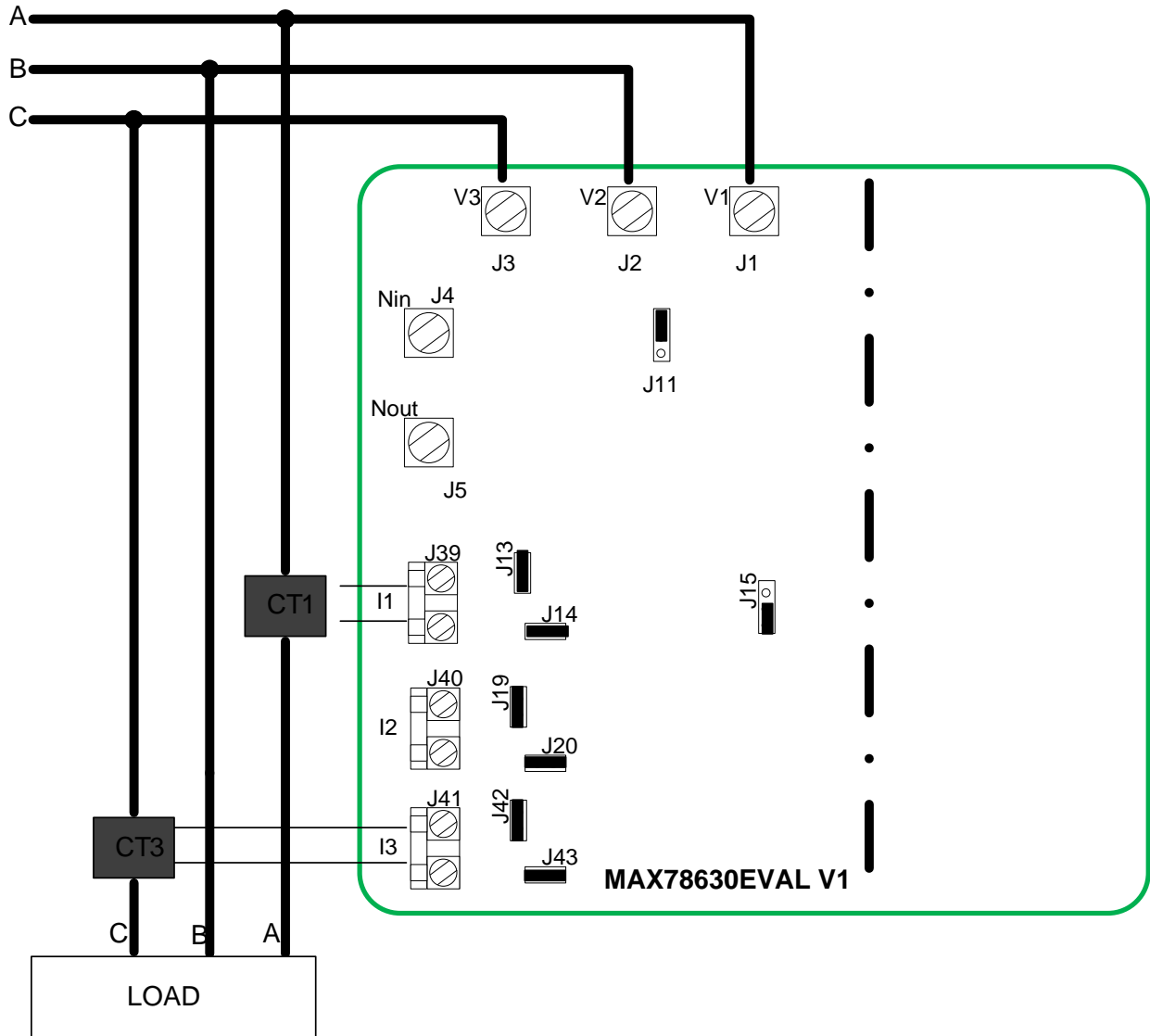

Figure 3: MAX78630+PPM EV Board Connections

1. Set Jumper J11 to position 1-2.
2. Set Jumper J15 to position 1-2.
3. Connect the AC source: Phase A to J1, phase B to J2 and Phase C to J3.
4. Connect Phase A current sensor' secondary side to J39.
  - a. if using a CT, enable burden resistor by closing jumper J13. Also close jumper J14 to disable the 2nd RC circuit.
  - b. if using a Rogowski coil, disable burden resistor by opening jumper J13. Also open jumper J14 to enable the 2nd RC circuit.
5. Connect Phase C current sensor' secondary side to J41.
  - a. if using a CT, enable burden resistor by closing jumper J42. Also close jumper J43 to disable the 2nd RC circuit.
  - b. if using a Rogowski coil, disable burden resistor by opening jumper J42. Also open jumper J14 to enable the 2nd RC circuit.
6. Always refer to the IC data sheet for proper connections according to the desired configuration.
7. Write the corresponding value of the CONFIG register to the MAX78630+PPM according to the configuration and the choice of sensors.

**Note:** If a phase is backwards, reverse the current flow through the respective current sensor.

### 2.3.3 Neutral Current Measurement Considerations

It is possible, in certain Wye configurations to measure the current in the neutral conductor via a shunt resistor, therefore replacing the third phase current measurement. This function is enabled by setting jumper J15 to position 2-3. The MAX78630+PPM EV board then connects the shunt voltage to input AIC of the MAX78630. IC (J41) is not measured in this case.

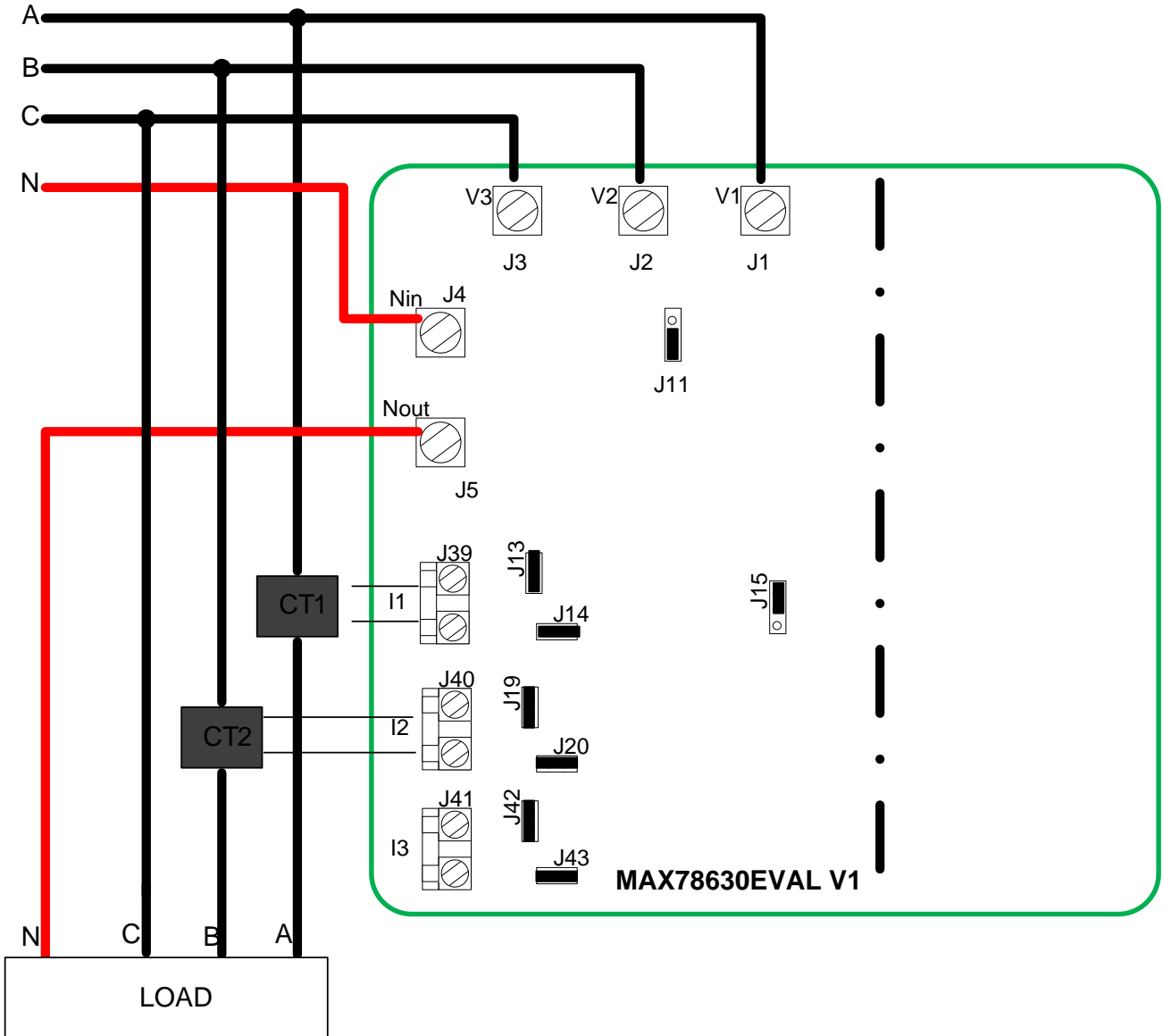

Figure 4: MAX78630+PPM EV Board Connections

## 2.4 Analog Input Jumper Descriptions

The following tables describe the various EV board jumpers that determine how analog signals are routed to the inputs of the MAX78630+PPM.

**Table 1: J15 Jumper Description**

J15 Pins	Description	Default
1/2	MAX78630+PPM measures current IC (J41) -Default	Installed
2/3	MAX78630+PPM measures shunt current IN (R11)	1/2

**Table 2: J11 Jumper Description**

J11 Pins	Description	Default
1/2	Measure two voltages (VB is reference) -Default	Installed
2/3	Measure three voltages (N is reference)	2/3

**Table 3: J13 Jumper Description**

J13 Pins	Description	Default
1/2	Insert burden resistor on IA (installed: enable, open: disable)	Installed

**Table 4: J19 Jumper Description**

J19 Pins	Description	Default
1/2	Insert burden resistor on IB (installed: enable, open: disable)	Installed

**Table 5: J42 Jumper Description**

J42 Pins	Description	Default
1/2	Insert burden resistor on IC (installed: enable, open: disable)	Installed

**Table 6: J14 Jumper Description**

J14 Pins	Description	Default
1/2	Enable 2nd RC filter on IA (installed: disable, open: enable)	Installed

**Table 7: J20 Jumper Description**

J20 Pins	Description	Default
1/2	Enable 2nd RC filter on IB (installed: disable, open: enable)	Installed

**Table 8: J43 Jumper Description**

J43 Pins	Description	Default
1/2	Enable 2nd RC filter on IC (installed: disable, open: enable)	Installed

### 3 Serial Interfaces Selection and Configuration

The MAX78630+PPM has integrated UART, SPI (Slave), and I<sup>2</sup>C (Slave) interfaces. Only one interface can be active at a time and the selection is done at reset/power-on.

The UART interface also supports RS-485/422. The MAX78M6630+PPM EV board includes an isolated RS-485/422 transceiver.

[Table 9](#) shows the settings of SW4 for the individual interface selection; the signal IFC0 and IFC1 are sampled at reset and power-on.

**Table 9: SW4 Serial Interface Selection**

Interface Mode	SW4 1 (IFC0)	SW4 2 (IFC1)
SPI	0 (ON)	X (don't care)
UART	1 (OFF)	0 (ON)
I <sup>2</sup> C	1 (OFF)	1 (OFF)

The MAX78630+PPM EV board provides the serial port signals on connector J16.

#### 3.1 UART Interface Settings

The MAX78M6630+PPM implements a serial communication protocol (SSI) that supports multipoint communication. The device address (lower bits) is selected through the pins **ADDR0** and **ADDR1**, as shown in [Table 10](#). The upper bits of the address are set through the register **DEVADDR**, as described in the IC data sheet.

**Table 10: SW5 Address Selection**

Device Address		
DEVADDR[5:1]	SW5 2 Bit 1	SW5 1 Bit 0

The EV board includes an isolated RS-485/422 transceiver. The MAX78630+PPM serial UART is connected to the RS-485/422 transceiver when a multi-drop RS-485/422 bus is available.

#### UART/USB Interface and UART/RS-485/422 Interface Configuration

In order to operate the UART through the USB/FTDI device or RS-485/422, the jumper must be set according to [Table 11](#).

**Table 11: Jumper Setting for UART/USB Interface**

Jumper	Position
J17	1-2
J18	1-2
J28	Removed
J29	Removed
J27	Removed
J38	Removed
J30	Removed
J12	Removed

### UART/RS-485/422 Interface Configuration

In order to operate the UART through the RS-485/422 transceiver, the jumpers must be set accordingly to [Table 12](#). [Table 13](#) contains the pin assignment of connector J22.

**Table 12: Jumpers Settings for UART/RS-485/422**

Jumper	Position
J17	2-3
J18	2-3
J28	Removed
J29	Removed
J27	(See note)
J38	(See note)
J30	Removed
J12	2-3

**Note:** These jumpers are used to insert a 120Ω termination on the RS-485 bus. The termination should be inserted or removed according to the board location on the RS-485 bus.

**Table 13: J22 RS-485/422 Connector Pin Assignment**

J22 Pin Number	Pin Name	Pin Description
1	+5V DC	Connect to external source
2	Data In – P	Three-state, bidirectional
3	Data In – N	Three-state, bidirectional
4	Data Out – N	Three-state, bidirectional
5	Data Out – P	Three-state, bidirectional
6	GND	Connect to external source

### 3.2 SPI Settings

The MAX78M6630+PPM has an on-chip SPI (slave) interface. The interface is selected through SW4 according to [Table 9](#). The SPI interface can be accessed through the USB interface or directly via J16; both connectors are galvanically isolated.

#### SPI/USB Interface Configuration

**Table 14: Jumper Setting for SPI/USB Interface**

Jumper	Position
J17	1-2
J18	1-2
J28	Inserted
J29	Inserted
J27	Removed
J38	Removed
J30	Inserted
J12	1-2

**SPI/J16 Interface Configuration****Table 15: Jumper Settings for Connecting on J16**

<b>Jumper</b>	<b>Position</b>
J17	Removed
J18	Removed
J28	Removed
J29	Removed
J27	Removed
J38	Removed
J30	Inserted
J12	1-2

**Table 16: J16 Connector Pin Assignment**

<b>Pin Number</b>	<b>Pin Name</b>	<b>Pin Description</b>
1	+5V DC	Connect to external source
2	SSB	SPI Slave Select (SS)
3	MISO	Slave Data Out
4	MOSI	Slave Data Input
5	SCK	Serial Clock
6	GND	Ground



## 4 Graphical User Interface (GUI)

A graphical user interface (GUI) is included on the MAX78630+PPM EV kit CD to facilitate quick evaluation of the MAX78630+PPM energy measurement device. The GUI requires Microsoft.NET Framework 4 on the PC for which the GUI is to execute on. Upon invoking the GUI executable file, an installation wizard may appear if Microsoft.NET Framework 4 is not installed on the PC. Follow the installation wizard instructions, or download Microsoft.NET Framework 4 from the Microsoft web site prior to launching the GUI.

### 4.1 GUI Initialization

The GUI is self-explanatory when used with the *MAX78630+PPM Data Sheet*. The user, however, should note the following about the EV kit hardware:

- Serial COM Port:
  - Following the installation instructions in Section 2, launch the GUI executable. Click the **Connection** pull-down menu and select **Connect**.



- The **COM Port / Baud Rate** box appears. Select the COM port assigned to the EV kit and leave the baud rate set to 38400 (default). Click the **Connect** button.

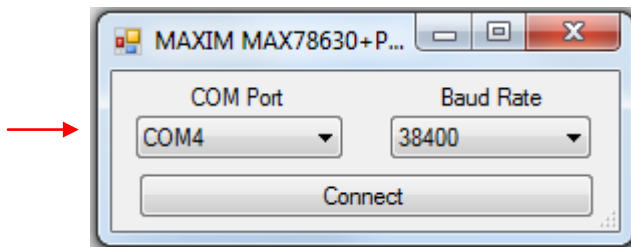

#### 4.1.1 SSI ID Tab

- SSI ID:
  - Click the **SSI** tab. Use the SSI ID number set by DIP switch 5 (1 and 2 are closed by default) and click **Set Target**. Upon successful communication with the EV kit, a message appears in the message box.

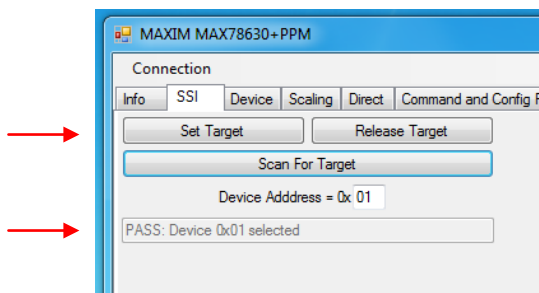

### 4.1.2 Device Tab

The **Device** tab shows to current firmware build as well as the temperature and line frequency being measured.

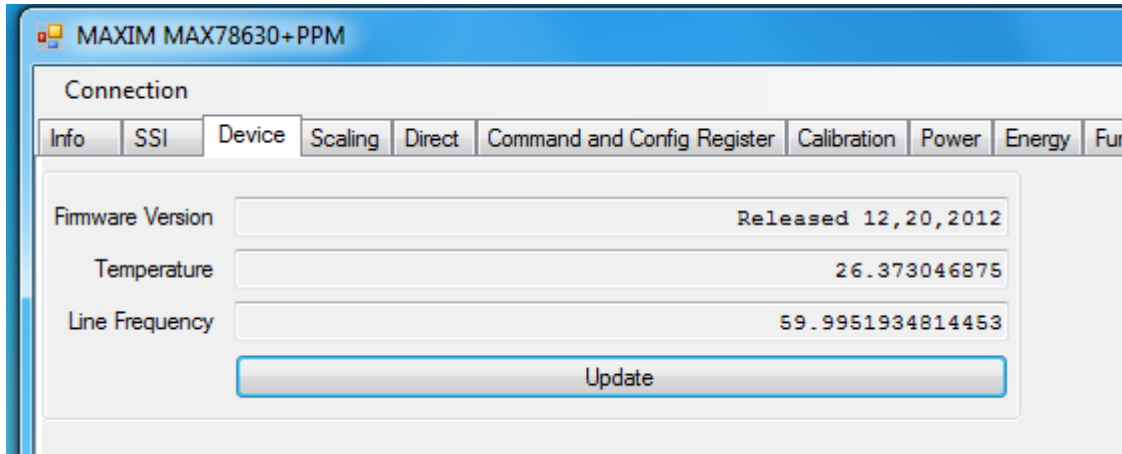

### 4.1.3 Scaling Tab

The **Scaling** tab is used to set the scale factors for voltages, currents, and power results. They should be set in accordance to the external circuitry that is being used. The scale factors are then used in the following result tabs to convert numeric results obtained from the MAX78630+PPM device to real world values.

The user can also choose to round the results (Power, Energy, Fundamental/Harmonics, Frequency and Temperature) to a specified number of decimal places.

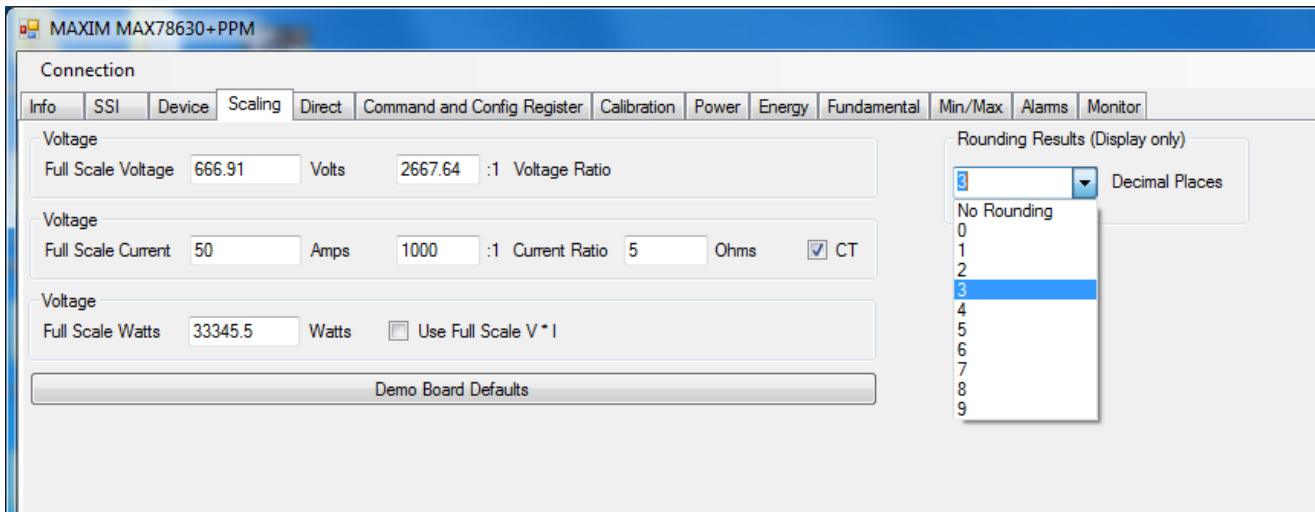

#### 4.1.4 Direct Tab

The **Direct** tab allows access to all the registers and can both read and write to the registers. The data can be displayed with the scale factor and units applied for convenience. In the example below, the voltage register is being read, so the volts option is used to display the data.

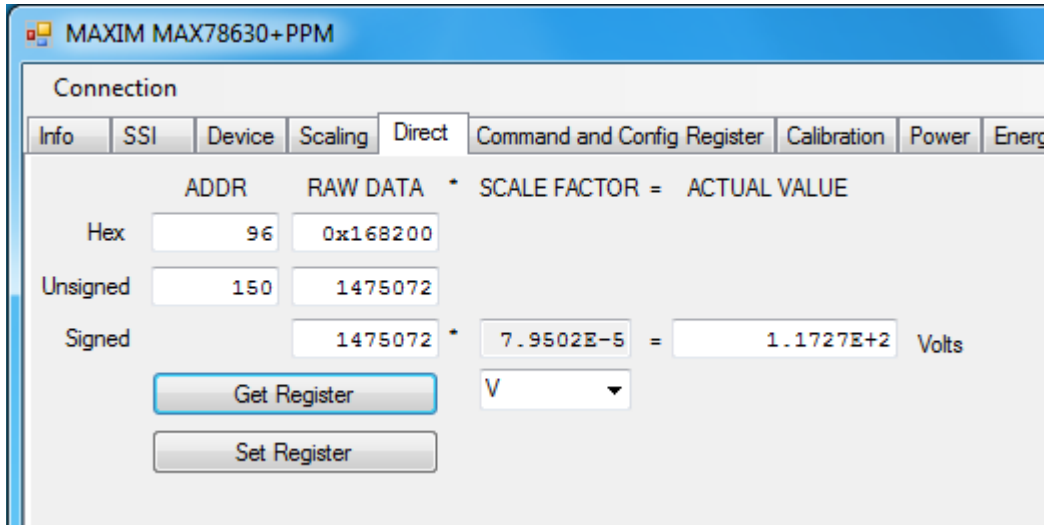

### 4.1.5 Command and Configuration Tab

The **Command and Config** tab controls two frequently used registers:

- Get and Set Command Register:** These buttons essentially do the same thing as the direct register reads and writes, but specifically for the command register while the **Direct** tab is for any other registers that need to be accessed. Hex and decimal formats are supported.
- Get and Set Configuration Register:** These buttons are used to set up the measurement configurations for the MAX78630+PPM. Refer to the IC data sheet Section 2.19 for details on how this is used. The configuration must be configured before the MAX78630+PPM is used by getting the default configuration and setting it. Once this is done it can be saved to NV RAM for future use, or programmed to a user-defined configuration and saved. See the **Calibration** tab for saving the settings.

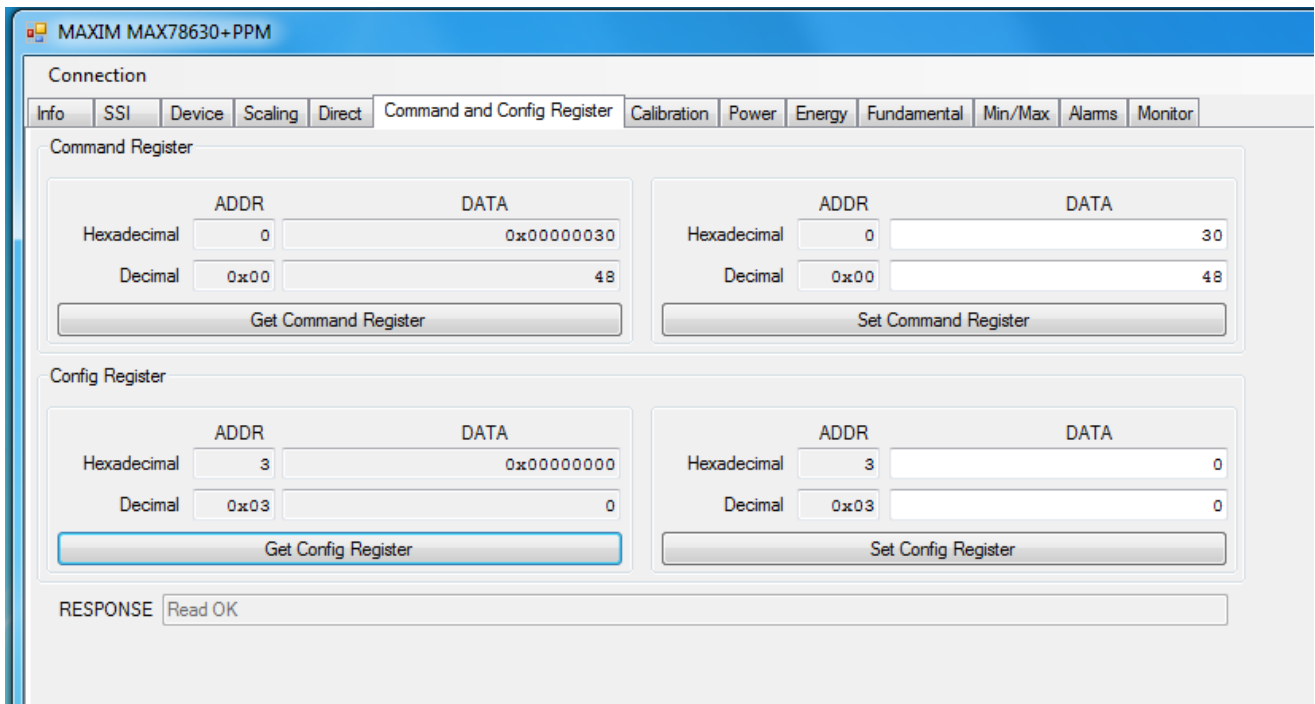

### 4.1.6 Calibration Tab

The **Calibration** tab is used to calibrate all the measurement channels. The calibration targets can be viewed and changed and the scaling parameters are also displayed for convenience. Use the **Calibration Options** to select the parameters to be calibrated. The calibration and NV RAM are also saved using the provided button.

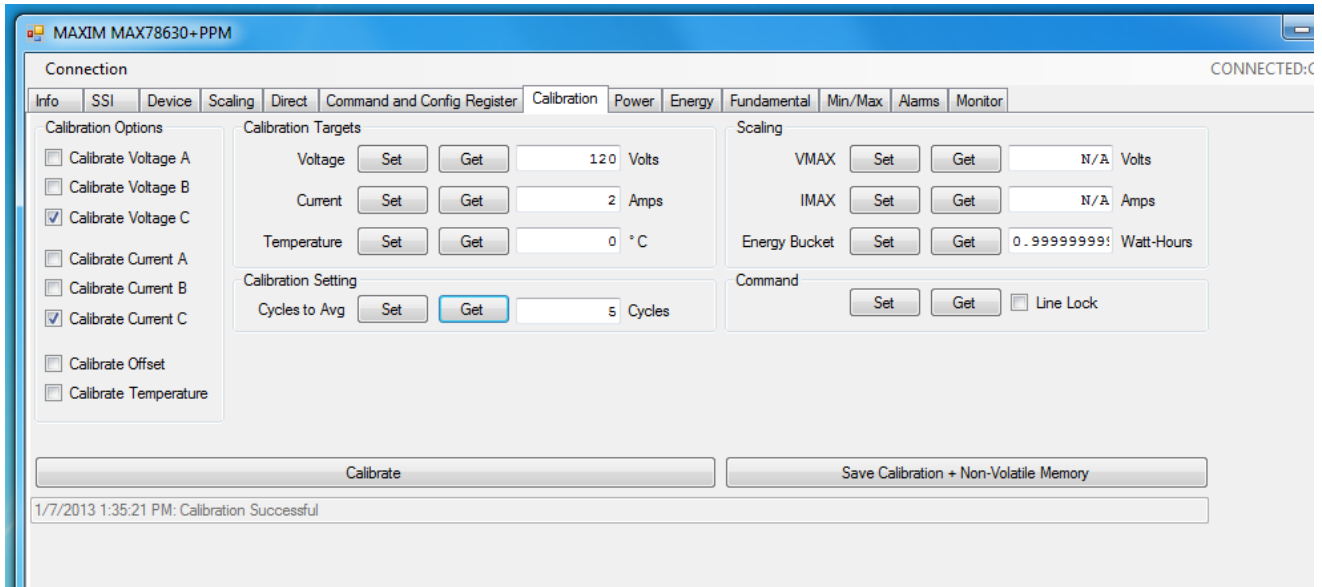

### 4.1.7 Power Tab

The **Power** tab displays the current power being consumed by the loads. P (active power), Q (reactive power), and S (apparent power) are displayed along with the voltage, current, crest factor, and power factor.

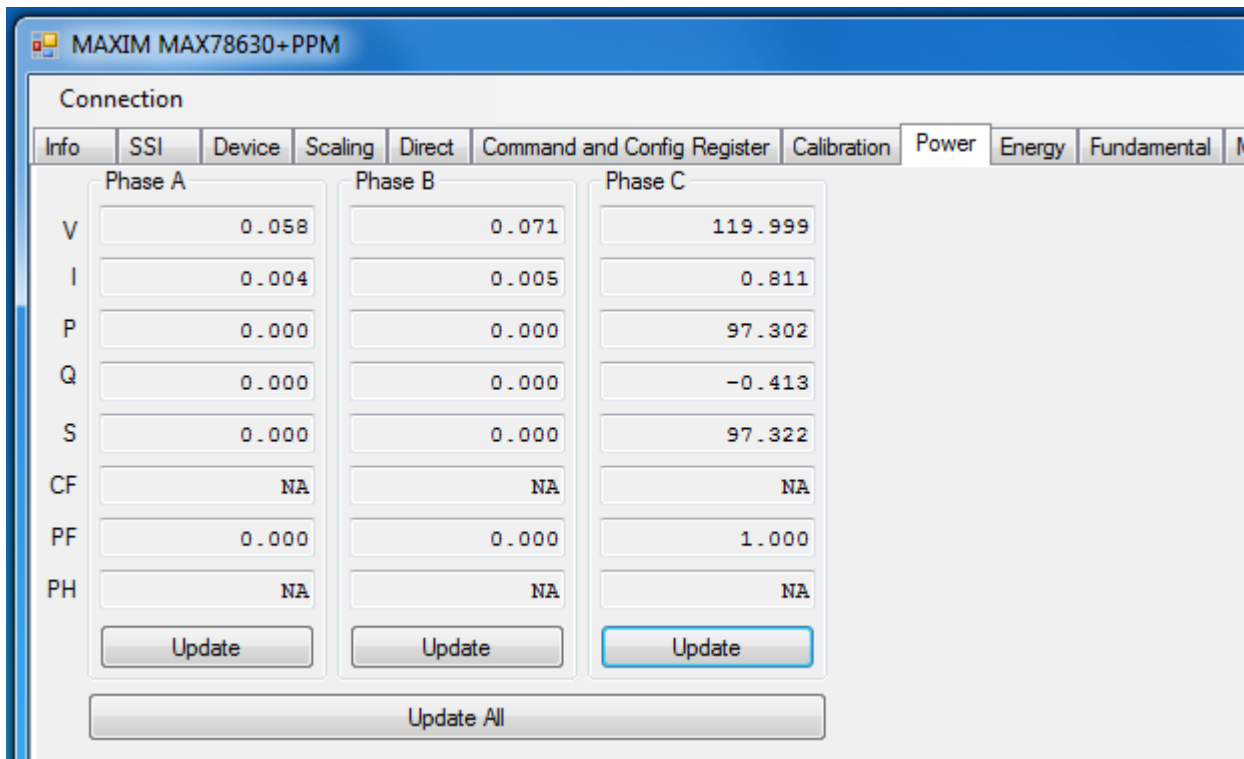

### 4.1.8 Energy Tab

The **Energy** tab displays the accumulated power both into and out of the load. All energy counters can be reset to zero in the device with the **Reset** button.

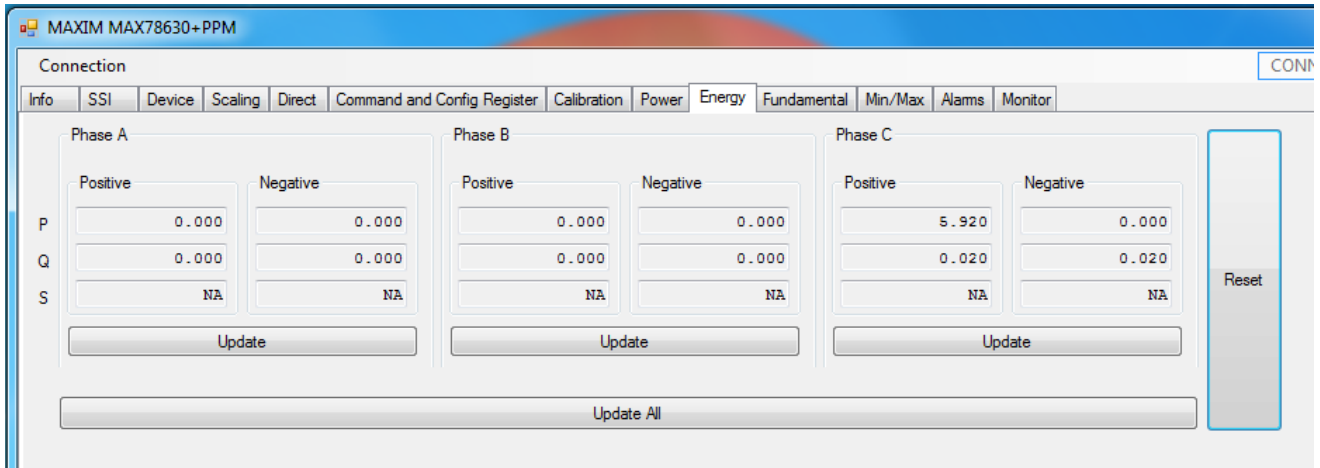

### 4.1.9 Fundamental Tab

The **Fundamental** tab is used to display the fundamental and harmonic measurements for voltage, current, and power. The harmonics displayed can be selected with the get/set harmonic buttons.

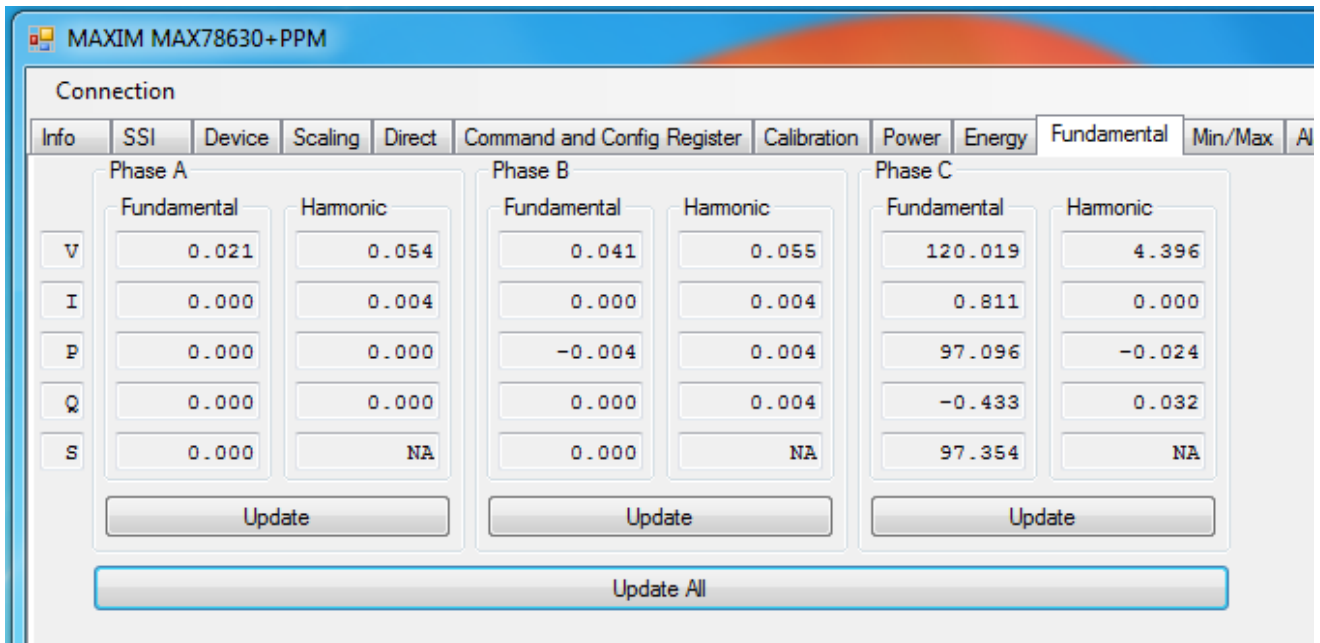

#### 4.1.10 Min/Max Tab

The **Min/Max** tab is used to display the minimum and maximum measurements for the parameters selected in the **Word Addr** column. The units can be selected with the provided pull-down menu and the most recent measurements are updated using the get buttons. All the measurements are reset with the reset button.

The screenshot shows the MAX78630+PPM software interface. The title bar reads "MAXIM MAX78630+PPM". Below the title bar is a "Connection" section. A tabbed menu at the top includes "Info", "SSI", "Device", "Scaling", "Direct", "Command and Config Register", "Calibration", "Power", "Energy", "Fundamental", "Min/Max", and "Ala". The "Min/Max" tab is active.

Word Addr	Min	Max	Unit
0x 32	119.976665443	120.009897224	V
0x 49	0.810027122	0.811088085	A
0x 0	0	0	UInt
0x 0	0	0	UInt
0x 0	0	0	UInt
0x 0	0	0	UInt
0x 0	0	0	UInt
0x 0	0	0	UInt
0x 0	0	0	UInt

At the bottom of the interface, there are two buttons: "Get All Addr" and "Get All Min/Max". A large "Reset" button is located on the right side of the table.

### 4.1.11 Alarm Tab

The **Alarm** tab is a user-definable display of whatever parameters are required in a particular application. The alarms are described in detail in Sections 2.11 and 2.12 of the MAX78630+PPM IC data sheet.

NAME	STATUS	STICKY	STATUS SET	STATUS RESET	MASK0	MASK4	MASK6	MASK7	MASK10
23: DRDY	<input checked="" type="checkbox"/>	<input checked="" type="checkbox"/>	<input type="checkbox"/>	<input type="checkbox"/>	<input type="checkbox"/>	<input type="checkbox"/>	<input type="checkbox"/>	<input type="checkbox"/>	<input type="checkbox"/>
22: OV_FREQ	<input checked="" type="checkbox"/>	<input checked="" type="checkbox"/>	<input type="checkbox"/>	<input type="checkbox"/>	<input type="checkbox"/>	<input type="checkbox"/>	<input type="checkbox"/>	<input type="checkbox"/>	<input type="checkbox"/>
21: UN_FREQ	<input type="checkbox"/>	<input checked="" type="checkbox"/>	<input type="checkbox"/>	<input type="checkbox"/>	<input type="checkbox"/>	<input type="checkbox"/>	<input type="checkbox"/>	<input type="checkbox"/>	<input type="checkbox"/>
20: OV_TEMP	<input checked="" type="checkbox"/>	<input checked="" type="checkbox"/>	<input type="checkbox"/>	<input type="checkbox"/>	<input type="checkbox"/>	<input type="checkbox"/>	<input type="checkbox"/>	<input type="checkbox"/>	<input type="checkbox"/>
19: UN_TEMP	<input type="checkbox"/>	<input checked="" type="checkbox"/>	<input type="checkbox"/>	<input type="checkbox"/>	<input type="checkbox"/>	<input type="checkbox"/>	<input type="checkbox"/>	<input type="checkbox"/>	<input type="checkbox"/>
18: OV_VRMSC	<input checked="" type="checkbox"/>	<input checked="" type="checkbox"/>	<input type="checkbox"/>	<input type="checkbox"/>	<input type="checkbox"/>	<input type="checkbox"/>	<input type="checkbox"/>	<input type="checkbox"/>	<input type="checkbox"/>
17: UN_VRMSC	<input type="checkbox"/>	<input checked="" type="checkbox"/>	<input type="checkbox"/>	<input type="checkbox"/>	<input type="checkbox"/>	<input type="checkbox"/>	<input type="checkbox"/>	<input type="checkbox"/>	<input type="checkbox"/>
16: OV_VRMSB	<input checked="" type="checkbox"/>	<input checked="" type="checkbox"/>	<input type="checkbox"/>	<input type="checkbox"/>	<input type="checkbox"/>	<input type="checkbox"/>	<input type="checkbox"/>	<input type="checkbox"/>	<input type="checkbox"/>
15: UN_VRMSB	<input type="checkbox"/>	<input checked="" type="checkbox"/>	<input type="checkbox"/>	<input type="checkbox"/>	<input type="checkbox"/>	<input type="checkbox"/>	<input type="checkbox"/>	<input type="checkbox"/>	<input type="checkbox"/>
14: OV_VRMSA	<input checked="" type="checkbox"/>	<input checked="" type="checkbox"/>	<input type="checkbox"/>	<input type="checkbox"/>	<input type="checkbox"/>	<input type="checkbox"/>	<input type="checkbox"/>	<input type="checkbox"/>	<input type="checkbox"/>
13: UN_VRMSA	<input type="checkbox"/>	<input checked="" type="checkbox"/>	<input type="checkbox"/>	<input type="checkbox"/>	<input type="checkbox"/>	<input type="checkbox"/>	<input type="checkbox"/>	<input type="checkbox"/>	<input type="checkbox"/>
12: UN_PFC	<input type="checkbox"/>	<input checked="" type="checkbox"/>	<input type="checkbox"/>	<input type="checkbox"/>	<input type="checkbox"/>	<input type="checkbox"/>	<input type="checkbox"/>	<input type="checkbox"/>	<input type="checkbox"/>
11: UN_PFB	<input type="checkbox"/>	<input checked="" type="checkbox"/>	<input type="checkbox"/>	<input type="checkbox"/>	<input type="checkbox"/>	<input type="checkbox"/>	<input type="checkbox"/>	<input type="checkbox"/>	<input type="checkbox"/>
10: UN_PFA	<input type="checkbox"/>	<input checked="" type="checkbox"/>	<input type="checkbox"/>	<input type="checkbox"/>	<input type="checkbox"/>	<input type="checkbox"/>	<input type="checkbox"/>	<input type="checkbox"/>	<input type="checkbox"/>
9: OV_IRMSC	<input checked="" type="checkbox"/>	<input checked="" type="checkbox"/>	<input type="checkbox"/>	<input type="checkbox"/>	<input type="checkbox"/>	<input type="checkbox"/>	<input type="checkbox"/>	<input type="checkbox"/>	<input type="checkbox"/>
8: OV_IRMSB	<input checked="" type="checkbox"/>	<input checked="" type="checkbox"/>	<input type="checkbox"/>	<input type="checkbox"/>	<input type="checkbox"/>	<input type="checkbox"/>	<input type="checkbox"/>	<input type="checkbox"/>	<input type="checkbox"/>
7: OV_IRMSA	<input checked="" type="checkbox"/>	<input checked="" type="checkbox"/>	<input type="checkbox"/>	<input type="checkbox"/>	<input type="checkbox"/>	<input type="checkbox"/>	<input type="checkbox"/>	<input type="checkbox"/>	<input type="checkbox"/>
6: VC_SAG	<input type="checkbox"/>	<input checked="" type="checkbox"/>	<input type="checkbox"/>	<input type="checkbox"/>	<input type="checkbox"/>	<input type="checkbox"/>	<input type="checkbox"/>	<input type="checkbox"/>	<input type="checkbox"/>
5: VB_SAG	<input type="checkbox"/>	<input checked="" type="checkbox"/>	<input type="checkbox"/>	<input type="checkbox"/>	<input type="checkbox"/>	<input type="checkbox"/>	<input type="checkbox"/>	<input type="checkbox"/>	<input type="checkbox"/>
4: VA_SAG	<input type="checkbox"/>	<input checked="" type="checkbox"/>	<input type="checkbox"/>	<input type="checkbox"/>	<input type="checkbox"/>	<input type="checkbox"/>	<input type="checkbox"/>	<input type="checkbox"/>	<input type="checkbox"/>
3: V_IMBAL	<input type="checkbox"/>	<input checked="" type="checkbox"/>	<input type="checkbox"/>	<input type="checkbox"/>	<input type="checkbox"/>	<input type="checkbox"/>	<input type="checkbox"/>	<input type="checkbox"/>	<input type="checkbox"/>
2: I_IMBAL	<input type="checkbox"/>	<input checked="" type="checkbox"/>	<input type="checkbox"/>	<input type="checkbox"/>	<input type="checkbox"/>	<input type="checkbox"/>	<input type="checkbox"/>	<input type="checkbox"/>	<input type="checkbox"/>
1: EXT_OSC	<input checked="" type="checkbox"/>	<input checked="" type="checkbox"/>	<input type="checkbox"/>	<input type="checkbox"/>	<input type="checkbox"/>	<input type="checkbox"/>	<input type="checkbox"/>	<input type="checkbox"/>	<input type="checkbox"/>
0: RESET	<input type="checkbox"/>	<input checked="" type="checkbox"/>	<input type="checkbox"/>	<input type="checkbox"/>	<input type="checkbox"/>	<input type="checkbox"/>	<input type="checkbox"/>	<input type="checkbox"/>	<input type="checkbox"/>



### 4.1.12 Monitor Tab

The **Monitor** tab is a running record of all the communications between the GUI and the target MAX78630+PPM. A log file can be generated to save the transactions for later analysis.

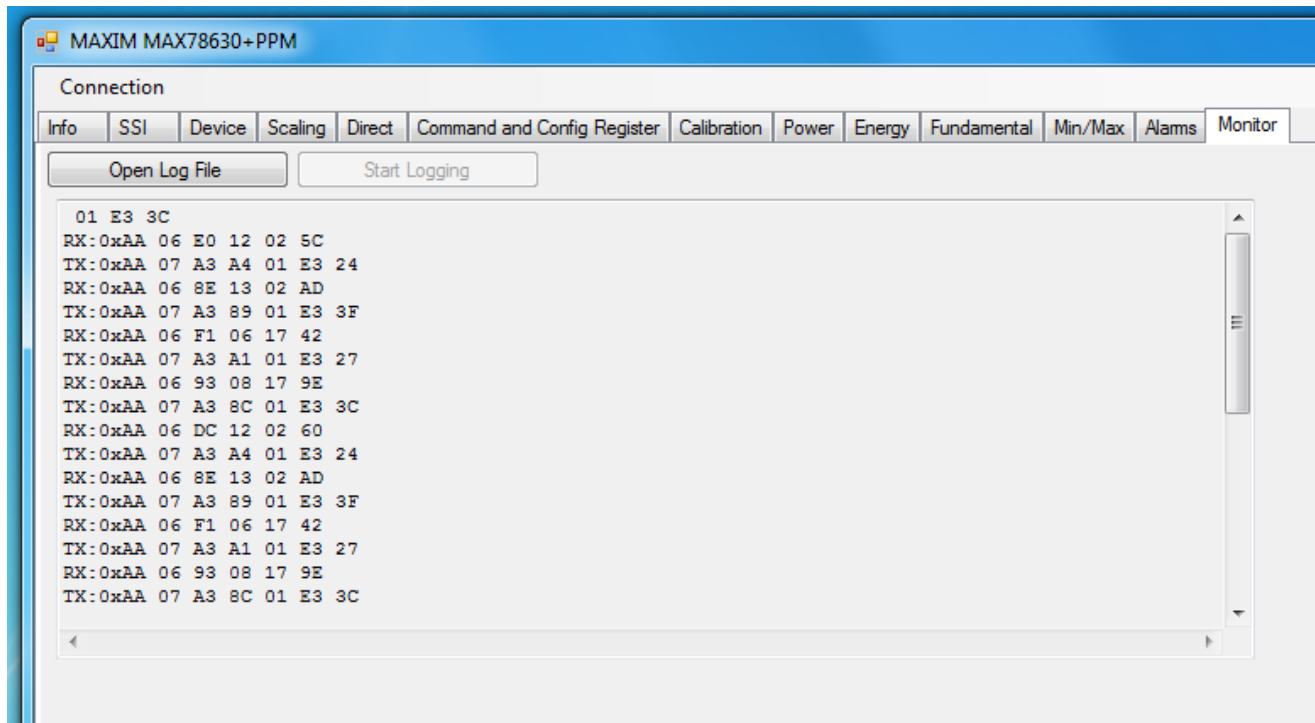

## 5 Schematics, Bill of Materials, and PCB Layouts

This section includes the schematics, bill of materials, and PCB layouts for the MAX78630+PPM EV board.

### 5.1 MAX78630+PPM EV Board Schematics

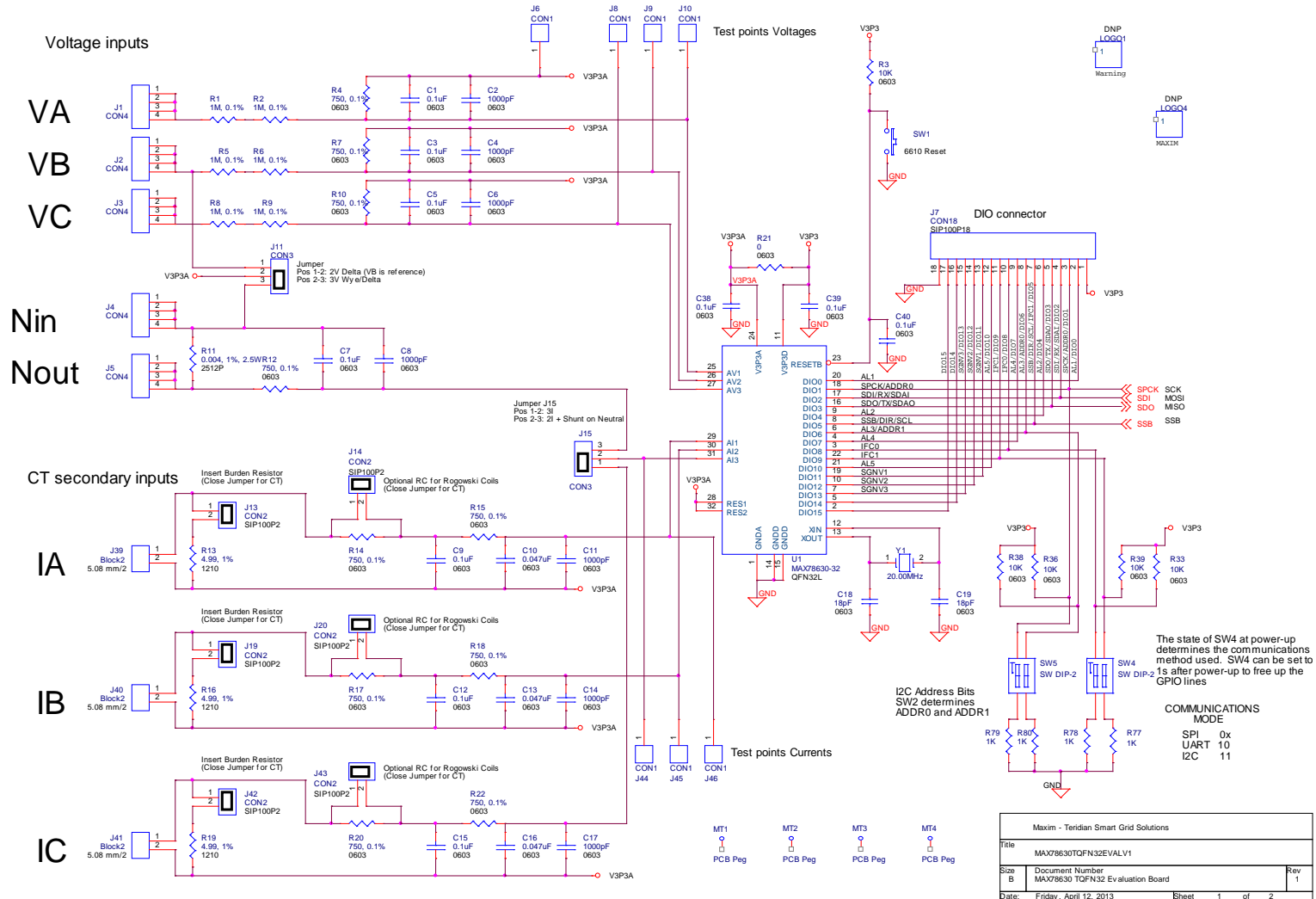

Figure 5: MAX78630+PPM EV Board Electrical Schematic (1 of 2)

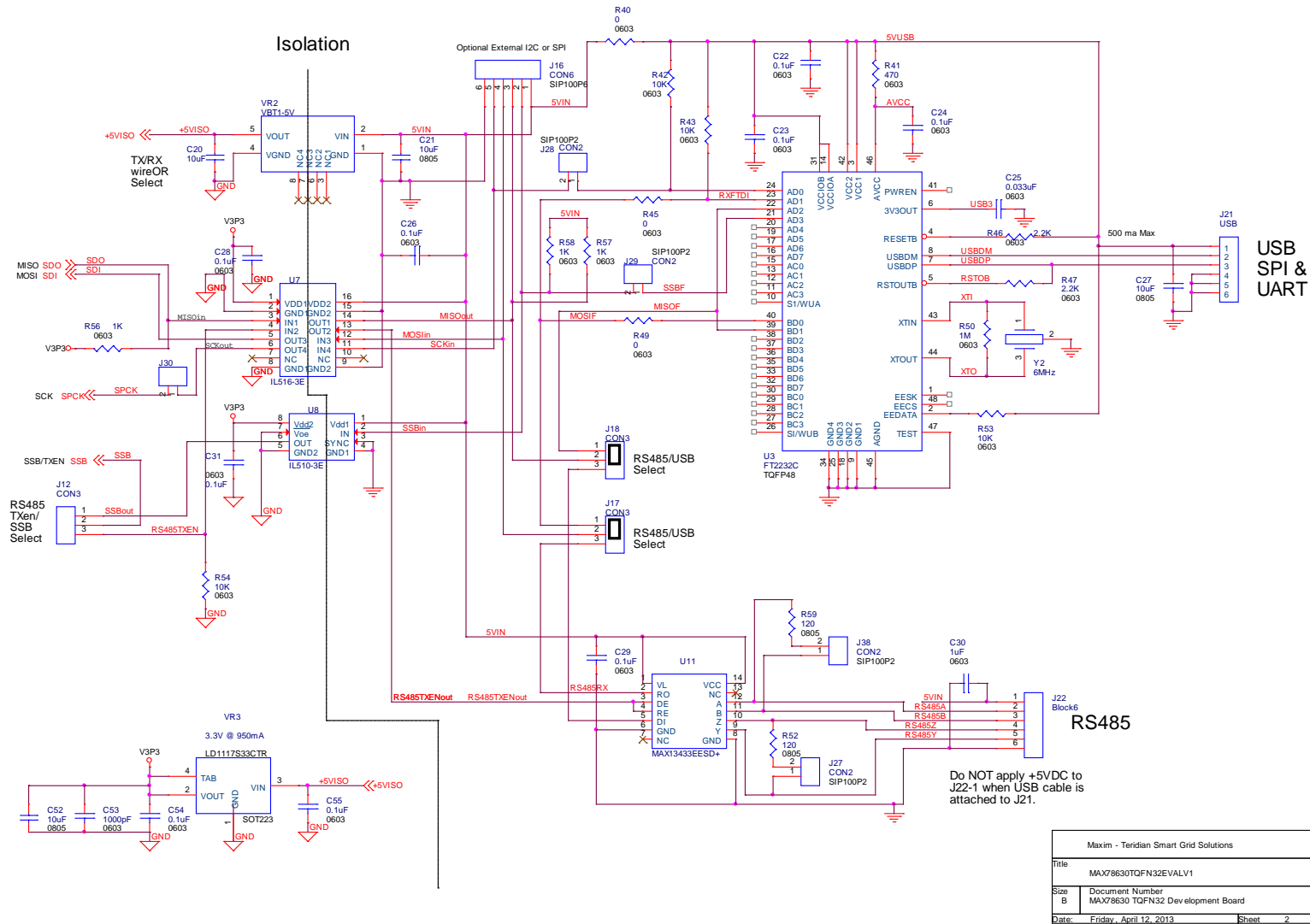

Figure 6: MAX78630+PPM EV Board Electrical Schematic (2 of 2)

## 5.2 MAX78630+PPM EV Board Bill of Materials

Table 17: MAX78630+PPM EV Board Bill of Materials

Item	Quantity	Reference	Part	PCB Footprint
1	19	C1,C3,C5,C7,C9,C12,C15,C22,C23,C24, C26,C28,C29,C31,C38,C39,C40,C54,C55	0.1uF	603
2	8	C2,C4,C6,C8,C11,C14,C17,C53	1000pF	603
3	3	C10,C13,C16	0.047uF	603
4	2	C18,C19	18pF	603
5	4	C20,C21,C27,C52	10uF	805
6	1	C25	0.033uF	603
7	1	C30	1uF	603
8	5	J1,J2,J3,J4,J5	CON4	STERM
9	7	J6,J8,J9,J10,J44,J45,J46	CON1	SIP100P1
10	1	J7	CON18	SIP100P18
11	5	J11,J12,J15,J17,J18	CON3	SIP100P3
12	11	J13,J14,J19,J20,J27,J28,J29,J30,J38,J42,J43	CON2	SIP100P2
13	1	J16	CON6	SIP100P6
14	1	J21	USB	USBB
15	1	J22	Block6	TERM BLK 200-6
16	3	J39,J40,J41	Block2	5.08 mm/2
17	4	MT1,MT2,MT3,MT4	PCB Peg	MTGPS.PRT
18	6	R1,R2,R5,R6,R8,R9	1M, 0.1%	1206W
19	9	R3,R33,R36,R38,R39,R42,R43,R53,R54	10K	603
20	10	R4,R7,R10,R12,R14,R15,R17,R18,R20,R22	750, 0.1%	603
21	1	R11	0.004, 1%, 2.5W	2512P
22	3	R13,R16,R19	4.99, 1%	1210

Table 17 continued

Item	Quantity	Reference	Part	PCB Footprint
23	4	R21,R40,R45,R49	0	603
24	1	R41	470	603
25	2	R46,R47	2.2K	603
26	1	R50	1M	603
27	2	R52,R59	120	805
28	7	R56,R57,R58,R77,R78,R79,R80	1K	603
29	1	SW1	PUSHBUTTON	EP11
30	2	SW4,SW5	SW DIP-2	DIP4
31	1	U1	MAX78630-32	QFN32L
32	1	U3	FT2232C	TQFP48
33	1	U7	IL516-3E	SO-16 NARROW
34	1	U8	IL510-3E	IL611A
35	1	U11	MAX13433EESD+	SO-14 NARROW
36	1	VR2	VBT1-5V	VBT1
37	1	VR3	3.3V @ 950mA	SOT223
38	1	Y1	20.00MHz	ABLS
39	1	Y2	6MHz	CSTCR





## 6 Contact Information

For more information about Maxim products or to check the availability of the MAX78630+PPM, contact technical support at [www.maximintegrated.com/support](http://www.maximintegrated.com/support).

### Revision History

REVISION NUMBER	REVISION DATE	DESCRIPTION	PAGES CHANGED
0	7/13	Initial release	—