



### Features

- Generates standard call progress tones
- Digital input control
- Linear (analog) output
- Power output capable of driving standard line
- 14-pin DIP and 16-pin SOIC package types
- Single supply 5V CMOS (low power)
- Inexpensive 3.58 MHz time base
- Temperature range from -25°C to 70°C

### Applications

- Telephone Systems
- Test Equipment
- Callback
- Security Systems
- Billing Systems

### Description

The M-991 is a call progress tone generator integrated circuit for use in telephone systems. The circuit uses low-power CMOS techniques to generate tones which are digitally controlled and highly linear. The M-991 is designed to permit operation with almost any system. The use of integrated circuit techniques allows the M-991 to incorporate the control, tone generating, and power output buffer into a single 14-pin DIP or 16-pin SOIC. A 3.58-MHz (color burst) crystal-controlled time base guarantees accuracy and repeatability.

### Ordering Information

Part #	Description
M-991	14-Pin Plastic DIP
M-991-01SM	16-Pin SOIC
M-991-01SMTR	16-Pin SOIC, Tape & Reel

### Pin Configuration

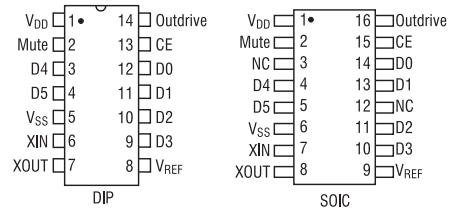

### Block Diagram

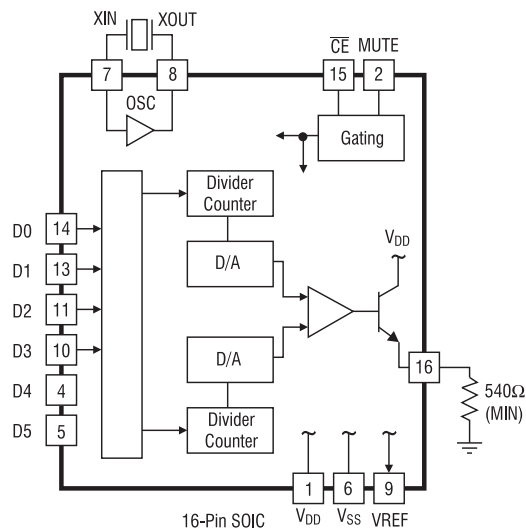
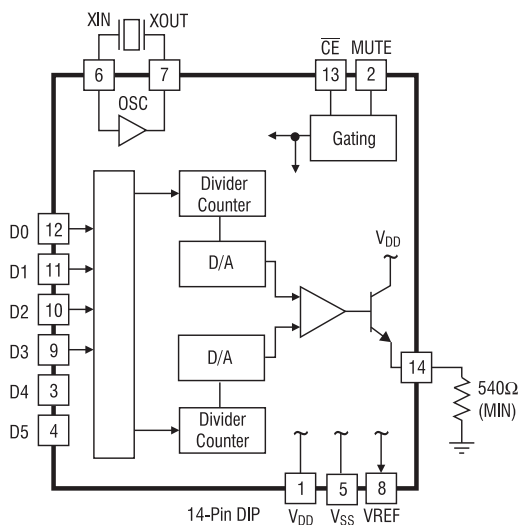

**Absolute Maximum Ratings**

Parameter	Ratings	Units
V <sub>DD</sub>	7	V
Any Input Voltage	V <sub>SS</sub> -0.6 to V <sub>DD</sub> +0.6	V
Operating Ambient Temperature	-25 to +70	°C
Storage Temperature	-55 to +125	°C

*Absolute Maximum Ratings are stress ratings. Stresses in excess of these ratings can cause permanent damage to the device. Functional operation of the device at these or any other conditions beyond those indicated in the operational sections of this data sheet is not implied. Exposure of the device to the absolute maximum ratings for an extended period may degrade the device and affect its reliability.*

**Specifications**

Parameter		Min	Typ	Max	Units	Notes
Power Supply and Reference	V <sub>DD</sub>	4.75	-	5.25	V	1
	Current Drain I <sub>DD</sub>	-	2/4	-	mA	8
	V <sub>REF</sub> Pin: Deviation From (V <sub>DD</sub> +V <sub>SS</sub> )/2	-2	-	+2	%	
	Internal Resistance From V <sub>REF</sub> to V <sub>DD</sub> , V <sub>SS</sub>	3.25	-	6.75	kΩ	
Oscillator	Frequency Deviation	-0.01	-	+0.01	%	7
	External Clock (XOUT Open)					
	V <sub>IL</sub>	0	-	0.2	V	
	V <sub>IH</sub>	V <sub>DD</sub> - 0.2	-	V <sub>DD</sub>		
	Duty Cycle	40	-	60	%	
XIN, XOUT Loading	Capacitance	-	-	10	pF	10
	Resistance	20	-	-	MΩ	-
Tone Output	Frequency Deviation	-0.5	-	+0.5	%	-
	Level	100	-	180	mV	2
	Distorting Components	-35	-	-	dB	3
	Idle	-	-	-60	dBm	4
	OUTDRIVE Envelope Rise Time	-	-	4	ms	5
Control	DX, CE Pins:					6
	V <sub>IL</sub>	-	-	0.5	V	
	V <sub>IH</sub>	2.5	-	-		
	Mute Pins:					
Timing	V <sub>OL</sub> (I <sub>SINK</sub> = -100μA)	-	-	1.5	V	
	V <sub>OH</sub> (I <sub>SOURCE</sub> = 100μA)	V <sub>DD</sub> - 1.5	-	-		
	Data Setup (t <sub>DS</sub> )	200	-	-	ns	11
	Data Hold (t <sub>DH</sub> )	10	-	-	ns	
	Chip Enable Fall (t <sub>PL</sub> )	-	-	90	ns	
	Turn On Delay (t <sub>TO</sub> )	-	-	5	ms	
	Turn Off Delay (t <sub>TD</sub> )	-	-	5	ms	
Mute Delay from Outdrive (t <sub>MO</sub> )	-	-	200	ns		

**Notes:** (Unless Otherwise Specified)

<sup>1</sup> All DC voltages are referenced to V<sub>SS</sub>.

<sup>2</sup> V<sub>rms</sub> per tone, 540Ω load.

<sup>3</sup> Any one frequency relative to the lowest level output tone (f<4000Hz)

<sup>4</sup> 0 dBm = 0.775V<sub>rms</sub>

<sup>5</sup> To 90% maximum amplitude.

<sup>6</sup> For all supply voltages in the operating range.

<sup>7</sup> At XOUT pin as compared to 3.579545MHz.

<sup>8</sup> OUTDRIVE with load > 5 kΩ/OUTDRIVE with 540Ω load.

<sup>9</sup> Resistance at V<sub>REF</sub> to V<sub>DD</sub> or V<sub>SS</sub> > 1MΩ.

<sup>10</sup> Crystal oscillator active.

<sup>11</sup> Measured 90% to 10%.

### Call Progress Tone Generation

Call progress tones are audible tones sent from switching systems to calling parties (or equipment) to indicate the status of calls. Calling parties can identify the success of a placed call by what is heard after dialing. The M-991 series utilizes a highly linear tone generator that produces the unique frequencies (singly or in pairs) that are common to call progress signals.

Duration and frequency selection are digitally controlled (see the Data/Tone Selection table below for data settings for a particular tone output). A typical control sequence for the M-991 is: (1) set data lines to desired frequency selection, (2) wait for data lines to settle, (3) drive the chip enable (CE) low, (4) maintain CE low for desired tone duration (Note: data lines may be changed after data hold time), and (4) return CE to a logic high. (Commonly used call progress tones are

shown in the Data/Tone Selection table below.) In a bus-oriented system, noise on the data lines may propagate through the device and appear at the output. To safeguard against this, use an external latch to lock the data into the device. In addition, it is good practice to bypass the  $V_{REF}$  pin to ground with a small capacitor (0.01 $\mu$ F) to reduce power supply noise. The designer should be aware of device timing requirements and design accordingly. The data input pins may be tied high (+5 VDC) or low (ground) as required, but D4 and D5 must be left open. Beware of hardwiring the CE pin for dedicated tone generation. This input is edge triggered. An RC network like that shown in the Power-on Reset Circuit on Page 4 should be used to momentarily reset the device immediately following power-up to ensure proper operation.

### Data/Tone Selection

D3	D2	D1	D0	Frequency (Hz)		Use
				1	2	
0	0	0	0	300	440	Dial Tone
0	0	0	1	400	off	Special
0	0	1	0	440	off	Alert Tone
0	0	1	1	440	480	Audible Ring
0	1	0	0	440	620	Pre-empt
0	1	0	1	480	off	Bell high tone
0	1	1	0	480	620	Reorder (Bell low)
0	1	1	1	350	off	Special
1	0	0	0	620	off	Special
1	0	0	1	941	1209	DTMF " * "

### Pin Function

Pin	Function
CE	Latches data and enables output (active low input)
D0 - D3	Data input pins (See Data/Tone Selection)
D4 - D5	Leave open
MUTE	Output indicates that a signal is being generated at OUTDRIVE.
OUTDRIVE	Linear buffered tone output.
$V_{DD}$	Most positive power supply input pin.
$V_{REF}$	Internally generated mid-power supply voltage (output).
$V_{SS}$	Most negative power supply input pin.
$X_{IN}$	Crystal oscillator or digital clock input.
$X_{OUT}$	Crystal oscillator output.

### Standard Call Progress Tones

Tone Name	Frequency (Hz)		Interruption Rate
	1	2	
Dial	350	440	Steady
Reorder	480	620	Repeat, tones on and off 250 ms $\pm$ 25 ms each.
Busy	480	620	Repeat, tones on and off 500 ms $\pm$ 50 ms each.
Audible Ring	440	480	Repeat, tones on 2 $\pm$ 0.2 s, tones off 4 $\pm$ 0.4 s
Recall Dial	350	440	Three bursts tones on and off 100 ms $\pm$ 20 ms each followed by dial tone.
Special AR	440	480	Tones on 1 $\pm$ 0.2s, followed by single 440 Hz on for 0.2s on, and silence for 3 $\pm$ 0.3 s, repeat.
Intercept	440	620	Repeat alternating tones, each on for 230 ms $\pm$ 70 ms with total cycle of 500 $\pm$ 50 ms.
Call Waiting	440	off	One burst 200 $\pm$ 100 ms
Busy Verification	440	off	One burst of tone on 1.75 $\pm$ 0.25 s before attendant intrudes, followed by burst of tone 0.65 $\pm$ 0.15 s on, 8 to 20 s apart for as long as the call lasts
Executive Override	440	off	One burst of tone for 3 $\pm$ 1 s before overriding station intrudes
Confirmation	350	440	Three bursts on and off 100 ms each or 100 ms on, 100 ms off, 300 ms on

**Power-On Reset Circuit**

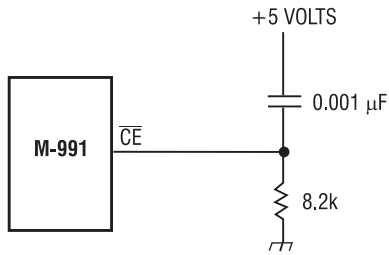

**Timing Diagram**

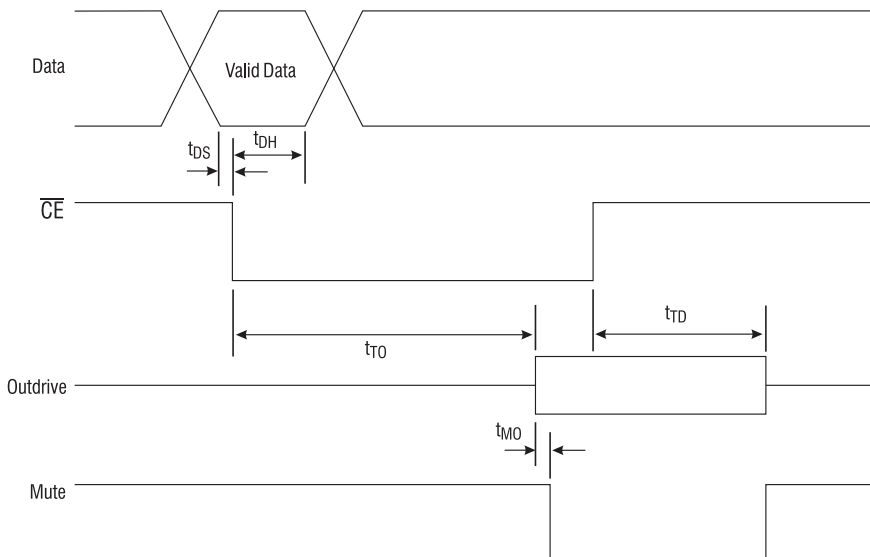

**Expanded Timing Diagram**

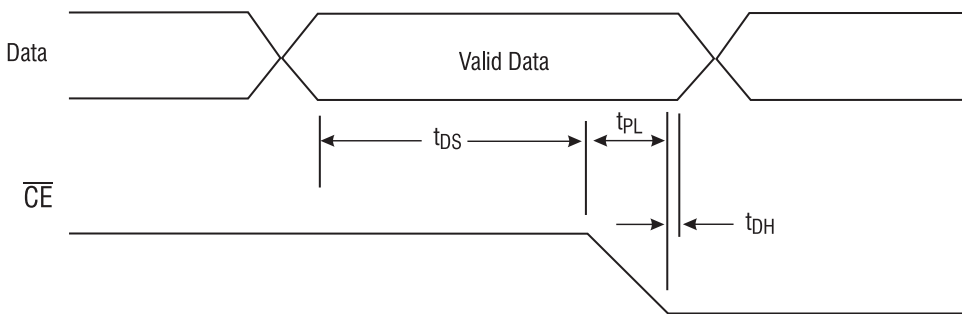

**Typical Application**

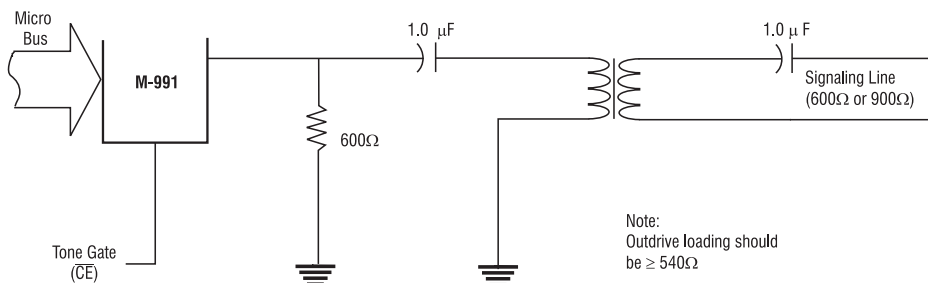

**Mechanical Dimensions**

**14-Pin DIP**

**14-Pin DIP**

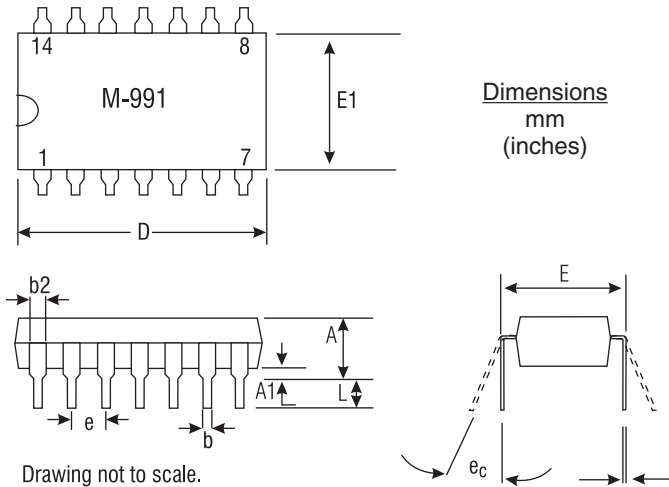

Drawing not to scale.  
Does not reflect actual part marking.

Tolerances				
	Inches		Metric (mm)	
	Min	Max	Min	Max
A	-	0.210	-	5.33
A1	0.15	-	0.38	-
b	0.014	0.022	0.36	0.56
b2	0.045	0.070	1.1	1.8
C	0.008	0.014	0.20	0.36
D	0.735	0.775	18.7	19.7
E	0.300	0.325	7.6	8.3
E1	0.240	0.280	6.1	7.1
e	0.100 BSC		2.54 BSC	
ec	0°	15°	0°	15°
L	0.115	0.150	2.9	4.1

**16-Pin SOIC**

**16-Pin SOIC**

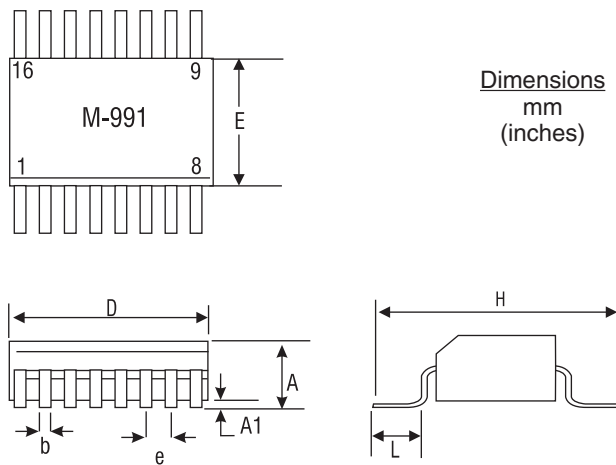

Drawing not to scale.  
Does not reflect actual part marking.

Tolerances				
	Inches		Metric (mm)	
	Min	Max	Min	Max
A	0.0926	0.1043	2.35	2.65
A1	0.0040	0.0118	0.10	0.30
b	0.013	0.020	0.33	0.51
D	0.3977	0.4133	10.10	10.50
E	0.2914	0.2992	7.4	7.6
e	0.050 BSC		1.27 BSC	
H	0.394	0.419	10.00	10.65
L	0.016	0.050	0.40	1.27

**For additional information please visit our website at: [www.ixysic.com](http://www.ixysic.com)**

IXYS Integrated Circuits Division makes no representations or warranties with respect to the accuracy or completeness of the contents of this publication and reserves the right to make changes to specifications and product descriptions at any time without notice. Neither circuit patent licenses nor indemnity are expressed or implied. Except as set forth in IXYS Integrated Circuits Division's Standard Terms and Conditions of Sale, IXYS Integrated Circuits Division assumes no liability whatsoever, and disclaims any express or implied warranty, relating to its products including, but not limited to, the implied warranty of merchantability, fitness for a particular purpose, or infringement of any intellectual property right.

The products described in this document are not designed, intended, authorized or warranted for use as components in systems intended for surgical implant into the body, or in other applications intended to support or sustain life, or where malfunction of IXYS Integrated Circuits Division's product may result in direct physical harm, injury, or death to a person or severe property or environmental damage. IXYS Integrated Circuits Division reserves the right to discontinue or make changes to its products at any time without notice.

Specification: DS-M-991-R03  
©Copyright 2012, IXYS Integrated Circuits Division  
OptoMOS® is a registered trademark of IXYS Integrated Circuits Division  
All rights reserved. Printed in USA.  
12/22/2012