

THIS DRAWING IS UNPUBLISHED. RELEASED FOR PUBLICATION, 19 .
 © COPYRIGHT 19 BY AMP INCORPORATED, HARRISBURG, PA. ALL INTERNATIONAL RIGHTS RESERVED. AMP PRODUCTS MAY BE COVERED BY U.S. AND FOREIGN PATENTS AND/OR PATENTS PENDING.

LOC		DIST		P		F		ZONE		LTR		REVISIONS		DATE	APPROVED
												0	RLSE NPR 1631	-	-
✓	✓											A	REV PER 0600-8209-99 JB	3-99	DE
												B	REV PER 063D-0091-99 JEB	3-00	DE

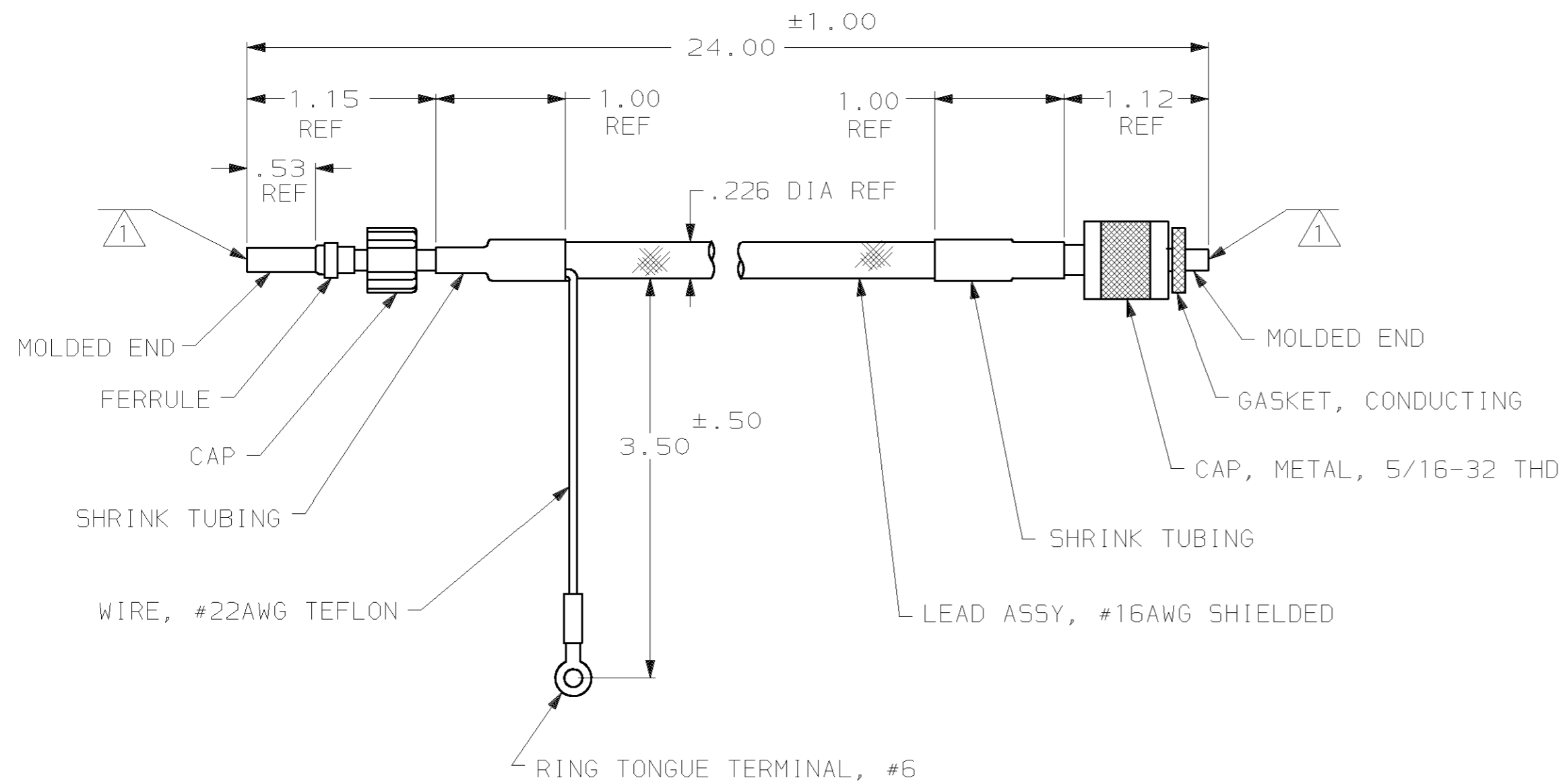

1 TO MATE WITH AMP LGH-1/2 RECEPTACLE WITH .53 BARREL DEPTH.
 2. MARKED PER MIL-STD-130.

868749-1
 PART NO

UNLESS OTHERWISE SPECIFIED DIMENSIONS ARE IN INCHES TOLERANCES ON :		DR -		AMP INCORPORATED Harrisburg, Pa. 17105		
2 PL DEC ± -		CHK -				
3 PL DEC ± -		APPD -		NAME LEAD ASSY, LGH-1/2		
ANGLES ± -		APPD -				
MATERIAL	-	PRODUCT SPEC		SIZE	FSCM NO	DRAWING NO
FINISH	-	APPLICATION SPEC		C	00779	868749
		WEIGHT		SCALE	NTS	SHEET 1 OF 1