

THIS DRAWING IS UNPUBLISHED. RELEASED FOR PUBLICATION  
 © COPYRIGHT - By - ALL RIGHTS RESERVED.

| LOC | DIST | REVISIONS |     |                                  |         |     |      |
|-----|------|-----------|-----|----------------------------------|---------|-----|------|
|     |      | P         | LTR | DESCRIPTION                      | DATE    | DWN | APVD |
| AF  | 50   |           | D3  | REDRAWN IN CAD PER ECR 12-010329 | 15JUN12 | JR  | LL   |

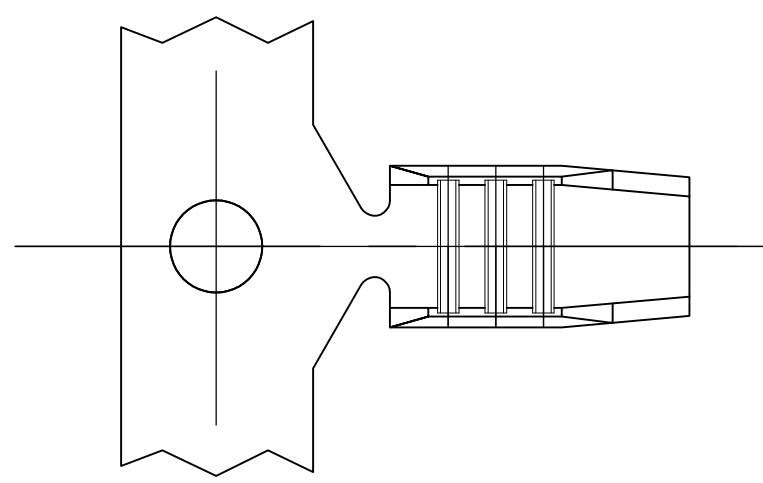

- 1 WIRE RANGE - TINNED LEAD WIRE 255-1855 CMA, COPPER LEAD WIRE 1250-1850 CMA.
- 2 APPLICABLE WIRE SIZES 26-18 AWG STRANDED WITH 40-26 AWG COPPER MAGNET.
- 3 PRE-STRIPPING OF THE MAGNET WIRE IS NOT REQUIRED.
- △ 4 REVERSE REELING, ALL REELING HAS THE BARREL U-ING DOWN.

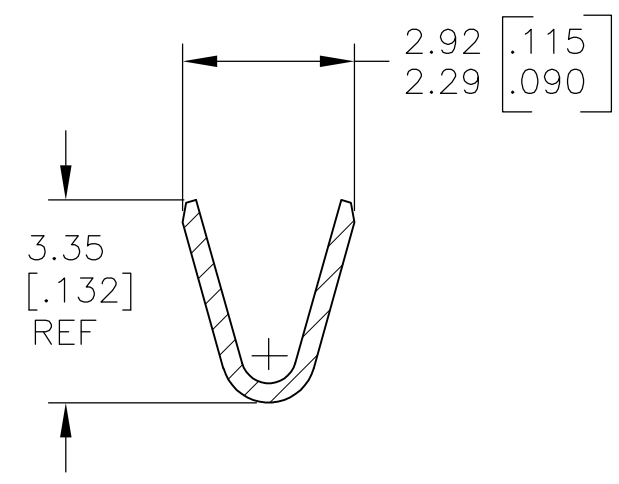
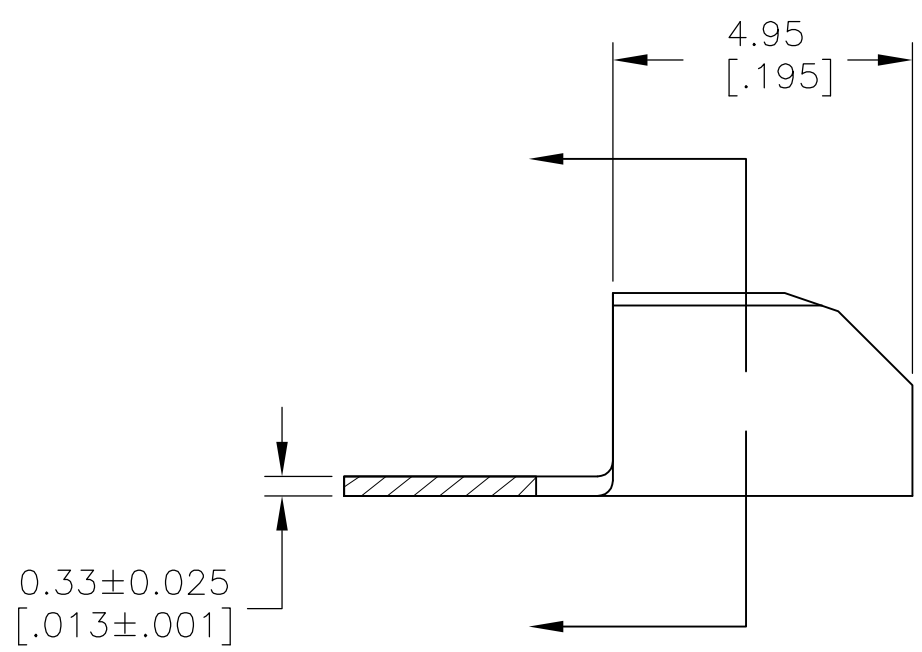

|     |          |           |           |          |
|-----|----------|-----------|-----------|----------|
| △ 4 | REVERSE  | TIN PLATE | 153212-2  | 153212-4 |
| △ 4 | REVERSE  | NONE      | 153212-1  | 153212-3 |
|     | STANDARD | TIN PLATE | 082 BRASS | 153212-2 |
|     | STANDARD | NONE      | 082 BRASS | 153212-1 |
|     | REELING  | FINISH    | MATERIAL  | PART NO. |

|  |               |                                  |   |                    |                        |                    |               |       |     |       |     |        |     |                   |   |  |
|--|---------------|----------------------------------|---|--------------------|------------------------|--------------------|---------------|-------|-----|-------|-----|--------|-----|-------------------|---|--|
| THIS DRAWING IS A CONTROLLED DOCUMENT.   |               | DWN<br>jr_ruth<br>01JUN12        | <b>STE</b> TE Connectivity              |                    |                        |                    |               |       |     |       |     |        |     |                   |   |  |
| DIMENSIONS:<br>MM [INCHES]   |               | CHK<br>LYONS LI<br>01JUN12       |   |                    |                        |                    |               |       |     |       |     |        |     |                   |   |  |
| TOLERANCES UNLESS OTHERWISE SPECIFIED:   |               | APVD<br>KURT RANDOLPH<br>01JUN12 | NAME<br>SPLICE, AMPLIVAR,<br>MINIATURE, |                    |                        |                    |               |       |     |       |     |        |     |                   |   |  |
| <table border="0"> <tr><td>0 PLC</td><td>± -</td></tr> <tr><td>1 PLC</td><td>± -</td></tr> <tr><td>2 PLC</td><td>± 0.25 [.010]</td></tr> <tr><td>3 PLC</td><td>± -</td></tr> <tr><td>4 PLC</td><td>± -</td></tr> <tr><td>ANGLES</td><td>± -</td></tr> </table> |               | 0 PLC                            | ± -                                     | 1 PLC              | ± -                    | 2 PLC              | ± 0.25 [.010] | 3 PLC | ± - | 4 PLC | ± - | ANGLES | ± - | PRODUCT SPEC<br>- | - |  |
| 0 PLC  | ± -           |                                  |   |                    |                        |                    |               |       |     |       |     |        |     |                   |   |  |
| 1 PLC  | ± -           |                                  |   |                    |                        |                    |               |       |     |       |     |        |     |                   |   |  |
| 2 PLC  | ± 0.25 [.010] |                                  |   |                    |                        |                    |               |       |     |       |     |        |     |                   |   |  |
| 3 PLC  | ± -           |                                  |   |                    |                        |                    |               |       |     |       |     |        |     |                   |   |  |
| 4 PLC  | ± -           |                                  |   |                    |                        |                    |               |       |     |       |     |        |     |                   |   |  |
| ANGLES   | ± -           |                                  |   |                    |                        |                    |               |       |     |       |     |        |     |                   |   |  |
| MATERIAL<br>SEE TABLE  |               | APPLICATION SPEC<br>-            | SIZE<br>A3                              | CAGE CODE<br>00779 | DRAWING NO<br>C-153212 | RESTRICTED TO<br>- |               |       |     |       |     |        |     |                   |   |  |
| FINISH<br>SEE TABLE  |               | WEIGHT<br>-                      | CUSTOMER DRAWING                        |                    | SCALE<br>8:1           | SHEET<br>1 OF 1    | REV<br>D3     |       |     |       |     |        |     |                   |   |  |