

MATERIAL:  
 PANEL MOUNTING RAILS - 14 GA. (0.08" [2.0] THK.) STEEL  
 ALL OTHER PARTS - 18 GA. (0.05" [1.2] THK.) STEEL

FINISH:  
 BLACK TEXTURED POWDER COATING

PANEL MOUNTING RAILS HAVE 0.35" [8.9] SQUARE HOLES  
 ON E.I.A. UNIVERSAL HOLE SPACING

SUPPLIED HARDWARE KIT TO INCLUDE:  
 QTY. (40) M6 CAGE NUT  
 QTY. (40) M6 PAN HEAD SCREW  
 QTY. (40) NYLON FLAT WASHER  
 QTY. (4) M10 x 2.25" [57.2] LG. STEM LEVELER W/HEX NUT  
 QTY. (8) KEYS

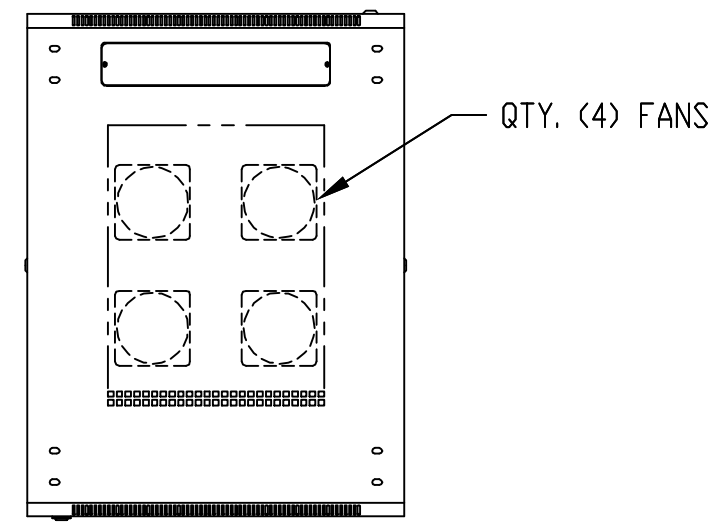

TOP VIEW

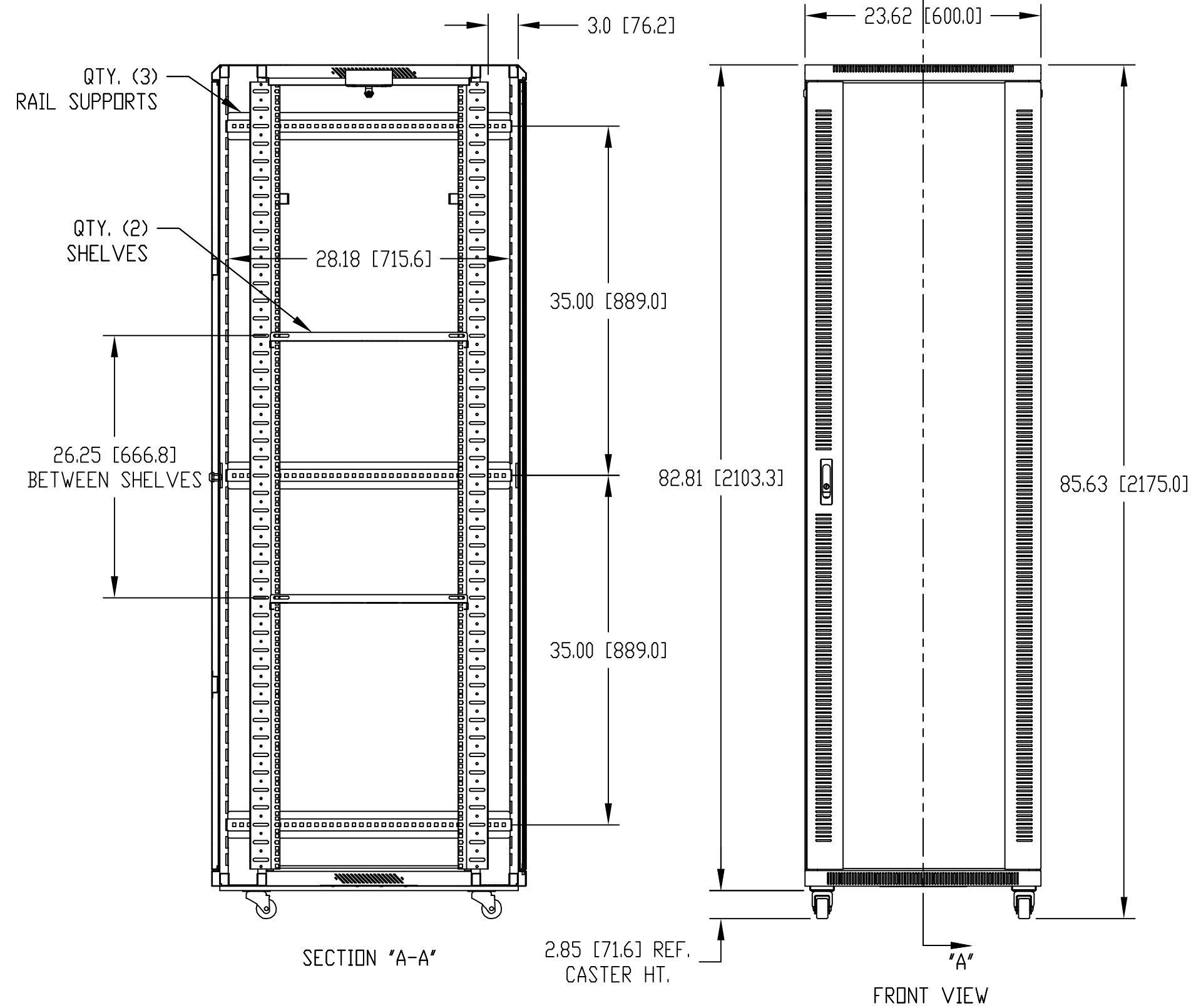

SECTION "A-A"

FRONT VIEW

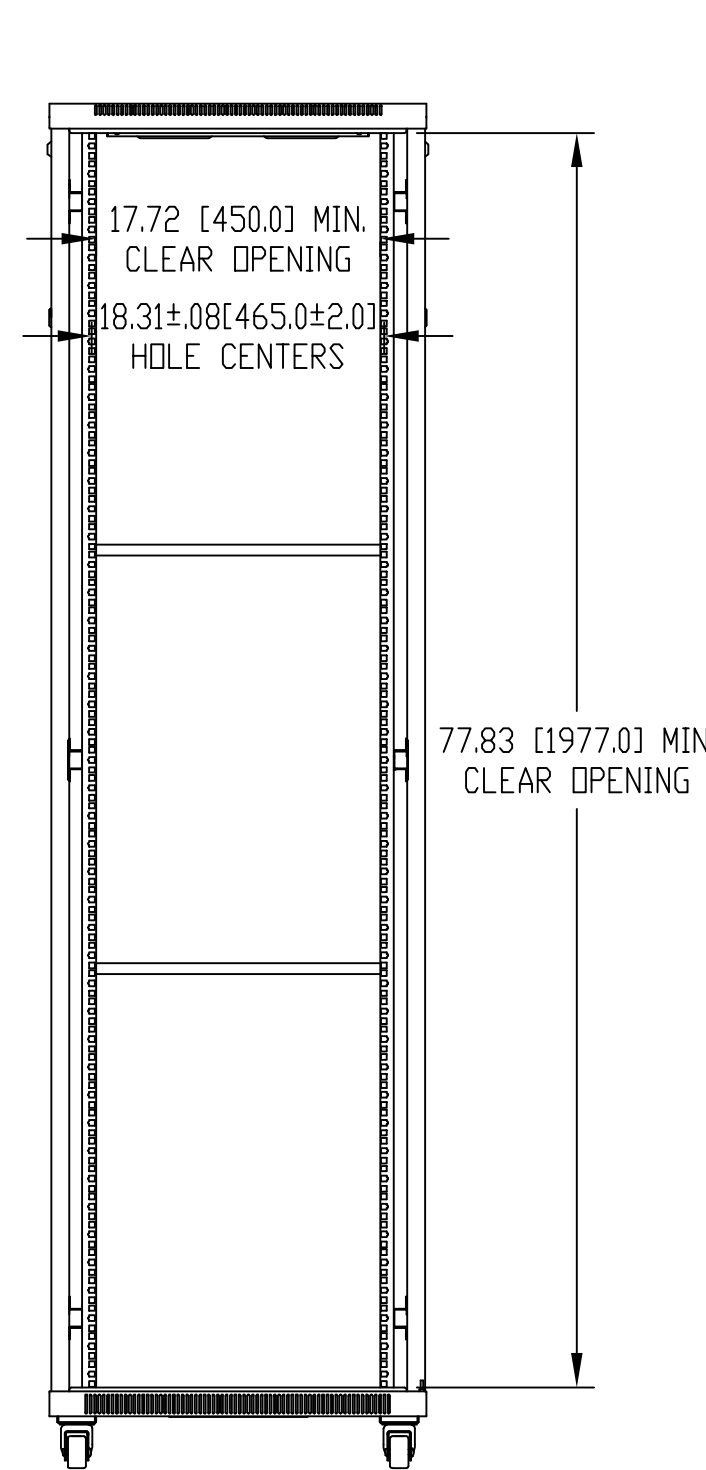

FRONT VIEW  
(DOOR REMOVED)

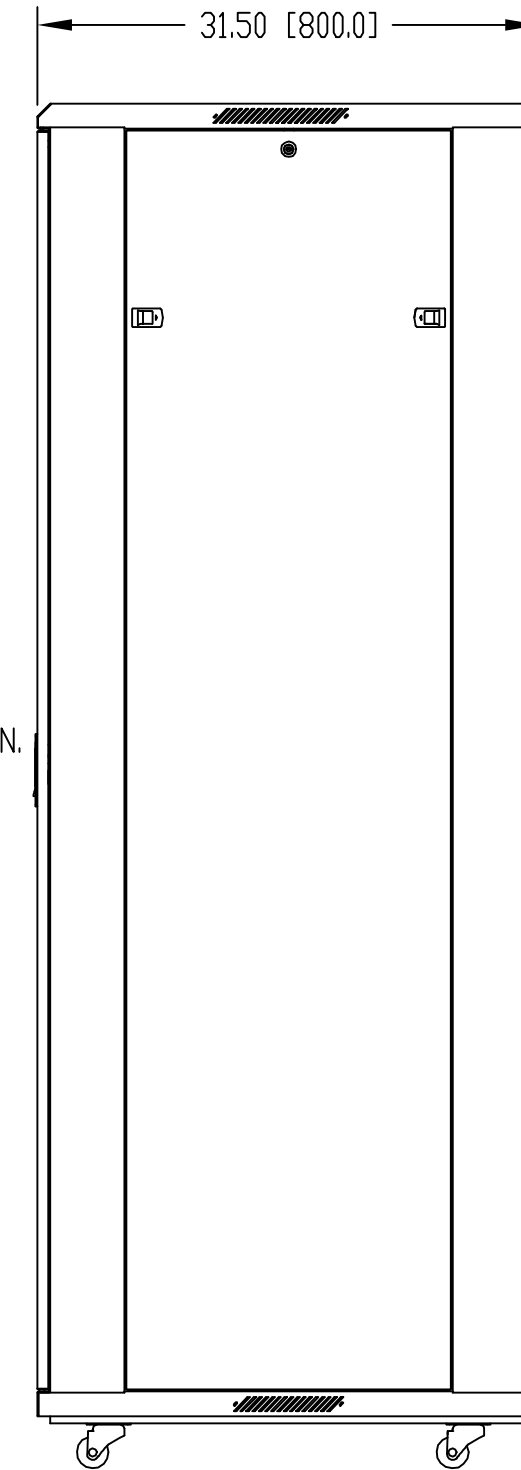

RIGHT SIDE VIEW

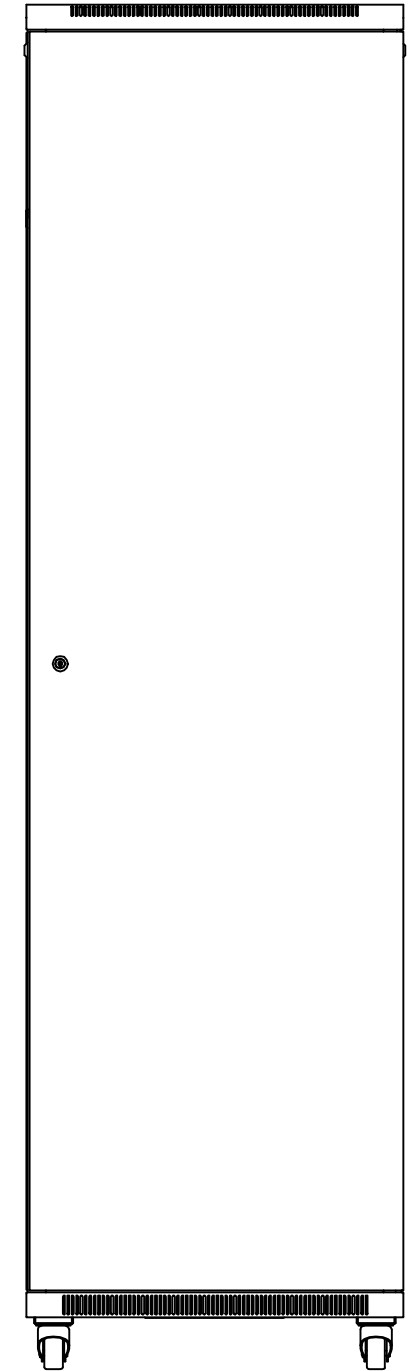

BACK VIEW

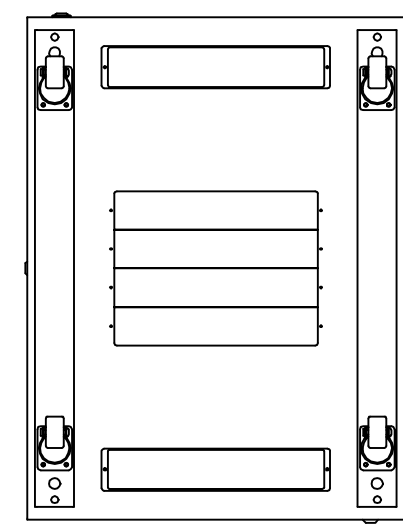

BOTTOM VIEW

TOLERANCE ALL DIMENSIONS: ±0.08" [2.0]

QTY.	USED ON	ITEM	REQ'D.	PART NO.	DESCRIPTION
		TOLERANCES:		MAT: AS NOTED	NAME:
		±.005 BETWEEN HOLE CENTERS		FINISH: AS NOTED	45U BUDRACK PROFESSIONAL SERIES
		±.015 FROM SHEARED EDGE		DR. DAB 6-20-08	
		±.032 FROM A BENT SURFACE		CH.	BUD INDUSTRIES, INC.
		±.063 BETWEEN ASSEMBLED SURFACES		APP.	WILLOUGHBY, OHIO
		UNLESS OTHERWISE SPECIFIED			DWG. NO. BRP-12218